



EWR – Newark, New Jersey
Junction Level Exterior Wall Insulation



EWR – Newark, New Jersey
Convective Heating Unit in Utility Chase



EWR – Newark, New Jersey
View of Elevator Shaft Interior



EWR – Newark, New Jersey
Suspect Mold Growth Under Cove Base, Ground Floor



BUR – Bob Hope Burbank Airport
Cab Roof HVAC Equipment – Clean and Well Maintained



BUR – Bob Hope Burbank Airport
Cab Exterior Window Caulk – Good Condition



BUR - Bob Hope Burbank Airport
6th Level Ceiling Tile Stain From Sanitary Drain Line



BUR - Bob Hope Burbank Airport
3rd Level – Small Amount of Mold Growth Near Window Which Was Re-caulked

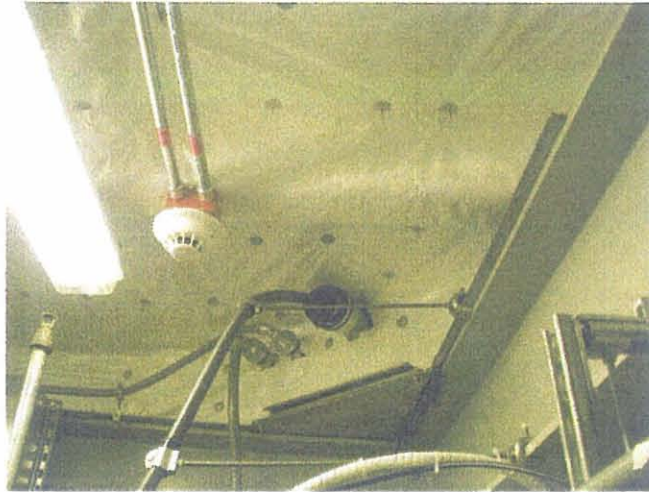

SEA – Seattle Tacoma
Cab Penthouse Ceiling is Insulated

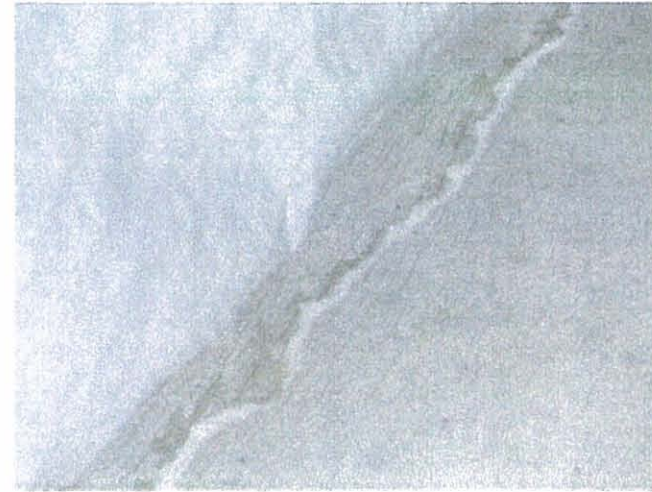

SEA - Seattle Tacoma
13th Level Floor Staining Under Existing
Fiberglass Insulation on Exterior Wall



SEA – Seattle Tacoma
Typical Slanted Exterior Wall Insulation Detail



SEA – Seattle Tacoma
10th Level Typical Wall Staining Likely From
Original Fireproofing Application



MCI – Kansas City
Junction Level Typical Exterior Wall



MCI – Kansas City
Cable Access Level Mold Contaminated Drywall Scrap (Removed and Discarded During Survey)



MCI – Kansas City
Typical Mold Abated Wall Area



MCI – Kansas City
Junction Level Room J10 Small (<6 in²) Patch of Visible Mold Growth



IAH – Houston
Room 2S3 Mold Below HVAC Duct

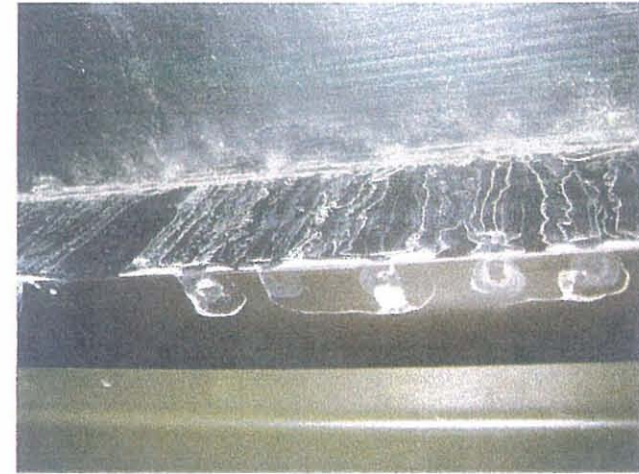

IAH – Houston
Junction Level Water Drip Residue on Restroom
Upper Window Frame



IAH – Houston
11th Level Fitness Room Condensation on Chilled
Water Valve and Affected Ceiling Tile



IAH – Houston
Cable Access Level Typical Interior Wall



DFW – East Tower Dallas/Fort Worth
Elevator Shaft Mold Spotting and Water Stain

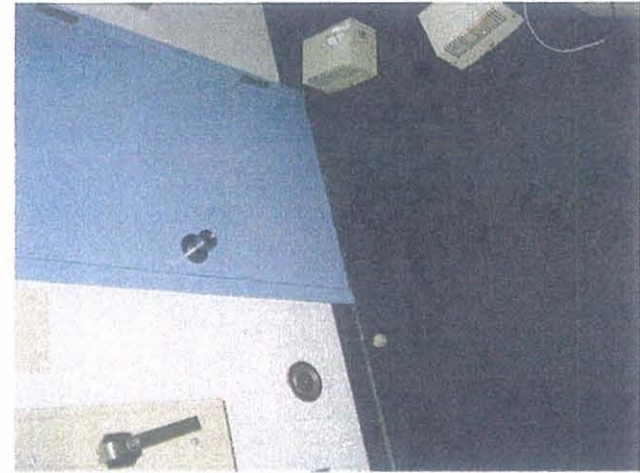

DFW – East Tower Dallas/Fort Worth
Subjunction Level Water Stained Carpet Below
Airshaft Door

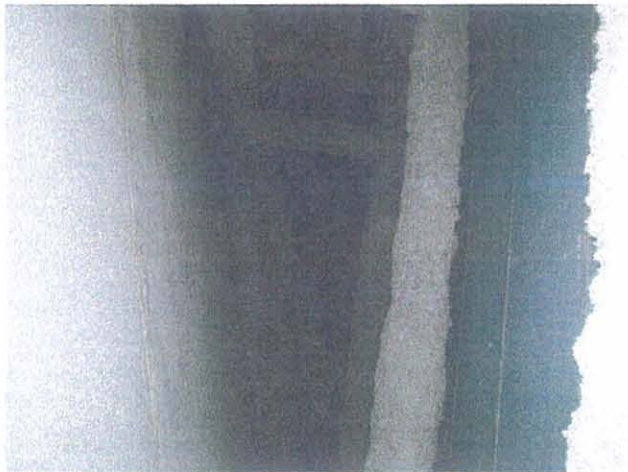

DFW – East Tower Dallas/Fort Worth
Typical Exterior Wall



DFW – East Tower Dallas/Fort Worth
Non-functional Area Mold Growth



DFW – West Tower Dallas/Fort Worth
Junction Level Insect Gains Entrance to Restroom Through Unsealed Crevice



DFW – West Tower Dallas/Fort Worth
Cable Access Level Unsealed Walls and Flashing Below Cab Balcony Allows Moisture Into Level.



DFW – West Tower Dallas/Fort Worth
Stairwell Window Exterior Deteriorated Caulk Identified as Source of Water Stain



DFW – West Tower Dallas/Fort Worth
Junction Level Mold Below Humidifier



CVG – Cincinnati/North Kentucky
Cable Access Level Exterior Wall With Water
Stains



CVG – Cincinnati/North Kentucky
Ground Level 8ft² Mold Growth in Plenum



CVG – Cincinnati/North Kentucky
Room 8TS3 Mold Growth and Water Stained
Wall



CVG – Cincinnati/North Kentucky
Junction Level Balcony Water Damaged Soffit



SDF – Louisville
NE Base of Tower Makeshift French Drain and Sump Pump



SDF – Louisville
Cable Access Level Insulated Exterior Wall and Metal Structural Members



SDF – Louisville
Tower Shaft Typical Insulated Pipe Chase Room

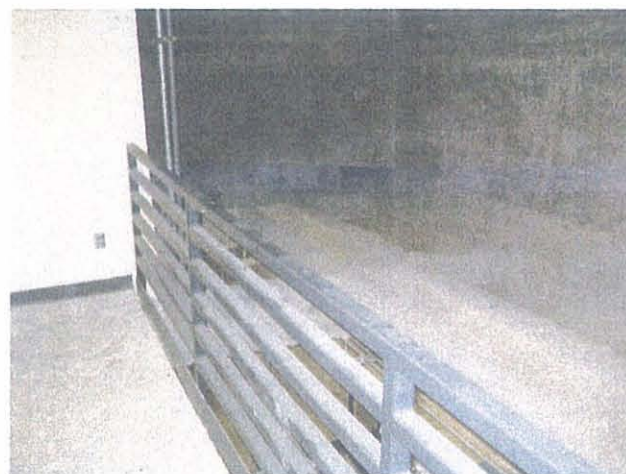

SDF – Louisville
Tower Shaft Typical Mezzanine Level Overlooking Full Level Below

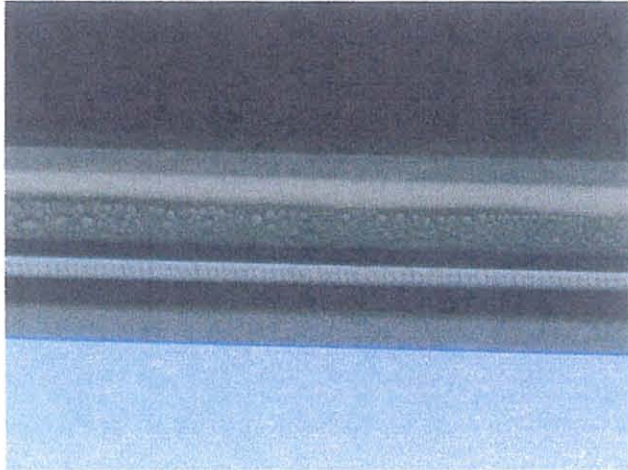

ORD – Chicago
Cab Level Condensation at Top of Window Frame



ORD – Chicago
Cable Access Level Exterior Wall with Insulation



ORD – Chicago
Mechanical Room Leaking Valve Repaired During Survey



ORD – Denver
Elevator Shaft Interior



DIA – Denver
Penthouse Roof Hatch With Condensation



DIA – Denver
Snow in Exterior Plenum of Cable Access Level



DIA – Denver
Subjunction Level Penetration to Microwave
Balcony Allows Rainwater to Enter



DIA – Denver
Cab Balcony Deteriorated Seam Caulk



UGN – Chicago Waukegan Regional
Opened Vertical Pipe Chase With Inadequate
Thermal Insulation



UGN – Chicago Waukegan Regional
Visible Mold Growth Inside of Wall – First Floor
Elevator Lobby



UGN – Chicago Waukegan Regional
5th Level Domestic Water Line Burst Creating
Flooding of Tower

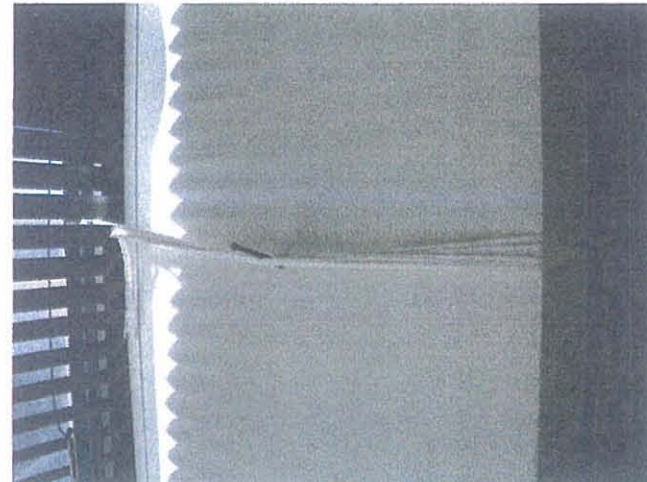

UGN – Chicago Waukegan Regional
Window Held In Place With String



AUS – Austin
Mold on Green Board Paper in Elevator Shaft



AUS – Austin
Junction Level Mold Contaminated Drywall
Below Supply Air Ductwork



AUS– Austin
Cab Balcony Deteriorated Seam Caulk



AUS – Austin
8th Level Mold Near Cement Floor



STL – Lambert St. Louis
Cable Access Level – Uninsulated Perimeter
Walls with Vents to Outdoors



STL – Lambert St. Louis
Cable Access Level – Wallboard and Insulation
on Inner Ring



STL – Lambert St. Louis
Drain in Air Shaft Modified to Prevent Pooling



STL – Lambert St. Louis
Suspect Mold Growth in Elevator Shaft

2009 APR 27 AM 11:38

**Air Traffic Control Tower (ATCT)
Mold/Water Incursion Inspections**

Listing of Documents Reviewed

**NISC Prime Contract Number
DTFAWA-08-00009
Task Order WESH802A
Applied Environmental, Inc.
Subcontract Number NISC2B-LM0500568-080116**

| Tab Number | Document Name and Date | Document Type | Author | Recipient | Description |
|-------------------|--|----------------------|---------------|------------------|--|
| 1 | Investigation of Mold and Moisture at the FAA Detroit Metropolitan ATCT Facility | Report | OST | FAA | This investigation was performed to determine if mold and moisture issues still affected the DTW ATCT as was alleged by some employees. It determined that fungal growth and water intrusion still affected the building. The report contained a recommendation to perform water damage assessments at other Leo Daly ATCTs. |
| 2 | Appendix A: Summary of Past Recommendations | Report | OST | FAA | This document is an appendix to the previous report that lists recommendations by various agencies and contractors. The |

Applied Environmental, Inc. ATCT Mold/Water Incursion Inspections

**Air Traffic Control Tower (ATCT)
Mold/Water Incursion Inspections
Listing of Documents Reviewed Continued
Page 2**

| Tab Number | Document Name and Date | Document Type | Author | Recipient | Description |
|-------------------|---|----------------------|--|---|--|
| | | | | | FAA's response to each recommendation is listed as well. Appendix outlines past recommendations and resolutions that occurred prior to the ATCT inspection project. |
| 3 | Whistleblower Investigation- Allegations of Mold & Moisture Problems at DTW | Memorandum | Linda Washington Asst. Secretary for Administration, Designated Agency S&H Official OST | Robert A. Sturgell Federal Aviation Administrator FAA | Document appears to be a cover letter for a list of recommendations developed during an OST investigation. It names three "whistleblowers" and requests an FAA response to the recommendations. Document contains interagency correspondence that occurred prior to the ATCT inspection project. |
| 4 | NIOSH Letter | Letter | Randy L. Tubbs Psychoacoustician NIOSH/DHHS | Wayne Vogelsburg CIH FAA | Closeout letter for NIOSH Health Hazard Evaluation at Detroit Metro Airport. The evaluation was performed by completing a review of consultant reports and medical |

**Air Traffic Control Tower (ATCT)
Mold/Water Incursion Inspections
Listing of Documents Reviewed Continued
Page 3**

| Tab Number | Document Name and Date | Document Type | Author | Recipient | Description |
|------------|------------------------|---------------|--|---|--|
| | | | | | records which are summarized in the letter. NIOSH recommended that water intrusion be eliminated from the ATCT and that water damaged and mold affected materials be removed from the building and that ill employees continue treatment through personal providers. Document discusses health hazard analysis performed prior to ATCT inspection project. |
| 5 | NIOSH Letter | Letter | Ayodele Adebayo Medical Officer NIOSH/DHHS | Jo L. Tarrh Director, Central Area for Technical Operations FAA | Letter from NIOSH stating that medical records of six air traffic controllers at the Detroit Metro Airport were reviewed. NIOSH stated that the information did not warrant changing the conclusions and recommendations forwarded after a Health Hazard Evaluation performed by the |

**Air Traffic Control Tower (ATCT)
Mold/Water Incursion Inspections
Listing of Documents Reviewed Continued
Page 4**

| Tab Number | Document Name and Date | Document Type | Author | Recipient | Description |
|-------------------|---|----------------------|--|---|---|
| | | | | | agency for the site. Document discusses medical surveillance performed prior to ATCT inspection project. |
| 6 | NIOSH Letter | Letter | David Sylvain Regional Industrial Hygienist NIOSH/DHHS | Jo L. Tarrh Director, Central Area for Technical Operations FAA | Letter to correct statement in previous letter. NIOSH was contacted and will review medical records provided by Dr. Michael Harbut. Document discusses medical surveillance performed prior to ATCT inspection project. |
| 7 | Microbial Remediation Project At Detroit Metropolitan Airport Air Traffic Control Tower | Specification | FAA | Contractors | Specification for the microbial remediation at Detroit Metro Airport ATCT. Includes abatement locations, expected work practices, clearance criteria, drawings, and an engineering cost estimate. Document provides guidance for an abatement project performed prior to the ATCT inspection project. |

**Air Traffic Control Tower (ATCT)
Mold/Water Incursion Inspections
Listing of Documents Reviewed Continued
Page 5**

| Tab Number | Document Name and Date | Document Type | Author | Recipient | Description |
|-------------------|---|----------------------|---|------------------|---|
| 8 | Microbial Remediation Project At Detroit Metropolitan Airport Air Traffic Control Tower | Specification | FAA | Contractors | Duplicate of Document 7 with the addition of FAA tracking, procurement, and funding documents and local permitting documents. |
| 9 | NISC SOW For Detroit ACTC Mold Inspection | Statement of Work | Lockheed Martin | Contractors | Scope of work for an inspection of the Detroit Metro Airport ATCT by an independent third party. Document describes inspection and reporting criteria. |
| 10 | FOH Indoor Air Quality/Fungal Consultation | Report | Federal Occupational Health USPHS/DHHS | FAA | Report from an indoor air quality survey and fungal inspection performed at the Detroit Metro Airport ATCT. A visual fungal inspection was performed throughout the ATCT, including the elevator shaft. Indoor air quality measurements, moisture measurements, an HVAC inspection, employee interviews, and reviews of past inspection documents were also |

**Air Traffic Control Tower (ATCT)
Mold/Water Incursion Inspections
Listing of Documents Reviewed Continued
Page 6**

| Tab Number | Document Name and Date | Document Type | Author | Recipient | Description |
|------------|--|---------------|-------------------------|-----------|--|
| | | | | | performed. Acceptable air quality was reported. Minor water damage was reported in some areas. Inspected HVAC system components were reported to be well maintained. This evaluation was performed prior to the ATCT inspection project. |
| 11 | Moisture Assessment Report-ATCT at Detroit Metropolitan Wayne County Airport | Report | Jacobs Facilities, Inc. | FAA | Report from a moisture and microbial assessment which included water damage, architectural, and mechanical inspections. Minor microbial growth and water damage were reported in some areas of the ATCT including the elevator shaft. Sources of water intrusion and moisture were identified as well as deficiencies in the HVAC system. A rough cost estimate to correct these conditions was also provided. |

**Air Traffic Control Tower (ATCT)
Mold/Water Incursion Inspections
Listing of Documents Reviewed Continued
Page 7**

| Tab Number | Document Name and Date | Document Type | Author | Recipient | Description |
|-------------------|--|----------------------|-------------------------------|--------------------------------|---|
| | | | | | Document describes an inspection performed prior to the ATCT inspection project. |
| 12 | Safety Risk Management Plan, Detroit Metro ATCT, Long Term Building Evaluation | Memorandum | FAA | FAA site personnel at DTW ATCT | Document provides a schedule for a site survey performed by Jacobs Facilities at the Detroit ATCT. A risk assessment for the activities performed during the survey is also provided. Document describes an inspection and associated risk assessment performed prior to the ATCT inspection project. |
| 13 | In The Matter Of An Arbitration Between FAA And NATCA, Local DTW/D21 | Report | Daniel M. Winograd Arbitrator | FAA NATCA | Report detailing the opinion of and award issued by the arbitrator for a grievance filed by NATCA. Grievance claimed unsafe working conditions. Document outlines a union grievance resolution which occurred prior to the current ATCT inspection project. |

Air Traffic Control Tower (ATCT)

Mold/Water Incursion Inspections

Listing of Documents Reviewed Continued

Page 8

| Tab Number | Document Name and Date | Document Type | Author | Recipient | Description |
|------------|---|---------------|--|--|--|
| 14 | Report on FAA's Actions to Address Mold at the Detroit Metropolitan Air Traffic Control Tower | Memorandum | David A. Dobbs Assistant Inspector General for Aviation and Special Program Audits, FAA | Federal Aviation Administrator FAA | Report details the results of a review of FAA actions to address mold in the DTW ACTC. The report was prepared at congressional request. The report concluded that materials exhibiting fungal growth had been remediated but repairs to correct moisture sources in the building had not been completed. A presentation for members of congress is also included. Document outlines remediation actions at the DTW ATCT prior to the ATCT inspection project. |
| 15 | OSHA Letter | Letter | Cynthia Hutchens-Smith Area Director OSHA | Joseph Figliuolo Air Traffic Manager DTW/FAA | The letter outlines the results of an OSHA inspection at the DTW ATCT. Though no visible fungal growth was identified, indications of water intrusion and HVAC deficiencies were observed. |

**Air Traffic Control Tower (ATCT)
Mold/Water Incursion Inspections
Listing of Documents Reviewed Continued
Page 9**

| Tab Number | Document Name and Date | Document Type | Author | Recipient | Description |
|-------------------|---|----------------------|---|--|--|
| | | | | | OSHA requested that these conditions be corrected. Document details an OSHA inspection at the DTW ATCT prior to the ATCT inspection project. |
| 16 | Whistleblower Investigation- Allegations of Mold & Moisture Problems at DTW | Memorandum | Steve Zaidman Vice President Technical Operations Services | Linda Washington Asst. Secretary for Administration, Designated Agency S&H Official OST | Memorandum provides a schedule for completion of corrective actions that were recommended in the <i>Investigation of Mold and Moisture at the FAA Detroit Metropolitan ATCT Facility</i> report. In Attachment 2, the author also disputes as inaccurate or misleading some statements made in the report and asks for changes to the document. One action to a recommendation in the above mentioned report was to perform inspections at other Leo Daly ATCTs. |

**Air Traffic Control Tower (ATCT)
Mold/Water Incursion Inspections
Listing of Documents Reviewed Continued
Page 10**

| Tab Number | Document Name and Date | Document Type | Author | Recipient | Description |
|-------------------|---------------------------------------|----------------------|--|------------------------------------|--|
| 17 | DTW Project Communication Plan | Correspondence | FAA | DTW site personnel and contractors | The plan outlines communication actions to be performed before and during all mold remediation, roof repair, or moisture mitigation projects. Many of these communication actions are performed before and during the subject ATCT inspections. |
| 18 | Appendix D: Industrial Hygiene Report | Report | M.A. Cecil, CIH M.A. Cecil and Associates | Thomas Black DOT | This IAQ/Microbial Assessment was performed following removal of mold affected materials in many areas of the DTW tower and base building. Fungal growth was discovered in wall cavities on two unoccupied floors. Microbial sampling in occupied areas and on these floors revealed no significant bacterial or fungal air concentrations. The contractor concluded that due to the location of the fungal growth |

**Air Traffic Control Tower (ATCT)
Mold/Water Incursion Inspections
Listing of Documents Reviewed Continued
Page 11**

| Tab Number | Document Name and Date | Document Type | Author | Recipient | Description |
|-------------------|---|----------------------|---|---------------------------------|---|
| | | | | | observed and the air concentrations measured, that FAA employees would not be significantly affected. Document describes an IAQ assessment of the DTW ATCT prior to the ATCT inspection project. |
| 19 | DTW ATCT WME Report Review Project #2006-0268 | Report | Robert D. Safe Safe Technology, Inc. | Wayne Vogelsburg, CIH FAA | Document is a review of a microbial assessment performed by Wonder Makers Environmental at the DTW ACTC. The author disputed the sampling methods used and the conclusion of the report that the ATCT was contaminated by fungal growth. The document references another assessment performed at the DTW ACTC that occurred prior to the current ATCT inspection project. |

**Air Traffic Control Tower (ATCT)
Mold/Water Incursion Inspections
Listing of Documents Reviewed Continued
Page 12**

| Tab Number | Document Name and Date | Document Type | Author | Recipient | Description |
|-------------------|---|----------------------|---|---------------------------------|--|
| 20 | Purchase Order 7100026924 – Mold Inspection, Detroit Air Traffic Control Tower | Report | David P. O’Konski CIH, CSP Applied Environmental, Inc. | James Burton Lockheed Martin | Document is a report detailing a visual mold inspection performed at the DTW ATCT. Water stained ceilings and damaged fireproofing was identified on some floors but no microbial growth or current water intrusion sources were identified. This inspection was performed prior to the subject ATCT inspection program. |
| 21 | Microbiological Remediation for FAA Detroit Metropolitan Wayne County Airport Traffic Control Tower | Statement of Work | Diane Morse FAA | Contractors | Document is a specification developed for a mold remediation project at the DTW ATCT. The remediation was performed prior to the current ATCT inspection program. |
| 22 | AUS ATCT Folder | Pictures | Unknown | Unknown | Folder contains a series of photographs presumably taken during an inspection of the ATCT at the Austin Bergstrom International Airport (AUS). The photos generally document |

**Air Traffic Control Tower (ATCT)
Mold/Water Incursion Inspections
Listing of Documents Reviewed Continued
Page 13**

| Tab Number | Document Name and Date | Document Type | Author | Recipient | Description |
|-------------------|--|----------------------|----------------------------|------------------|--|
| | | | | | water damaged materials though other images are present. These photographs were taken during an inspection performed prior to the subject ATCT inspection project. |
| 23 | Mold Evaluation – Kansas City, Missouri Airport Traffic Control Tower | Report | Unknown | Unknown | Document is a report detailing a microbial evaluation that included surface and bulk sampling for fungal growth at the MCI ATCT and base building. Elevated fungal concentrations were reported in some areas. This evaluation was performed prior to the current ATCT inspection program. |
| 24 | Post Mold Remediation Clearance Report – Kansas City, Missouri Airport Traffic Control Tower | Report | Barbara Hebert NISC CIH | Unknown | Document is a report detailing a clearance inspection and sampling following remediation at the MCI ATCT. It stated that all work areas were eventually cleared by visual inspection |

**Air Traffic Control Tower (ATCT)
Mold/Water Incursion Inspections
Listing of Documents Reviewed Continued
Page 14**

| Tab Number | Document Name and Date | Document Type | Author | Recipient | Description |
|-------------------|--|----------------------|------------------------------|------------------|---|
| | | | | | and/or air sampling. This remediation and inspection were performed prior to the current ATCT inspection program. |
| 25 | Report on Mold and Moisture inspection – Kansas City International Airport , Airport Traffic Control Tower | Report | Unknown | FAA | Document describes the history of water intrusion and fungal growth in the MCI ATCT. It also describes the activities performed during the most recent microbial inspection there. This document describes an inspection that was performed prior to the current ATCT inspection program. |
| 26 | Microbiological Remediation and Restoration - Airport Traffic Control Tower Kansas City International Airport, Kansas City, Missouri | Specification | DOT/FAA Central Service Area | Contractors | Document is a specification developed for a mold remediation project at the MCI ATCT. It includes the affected areas, expected work practices, and clearance protocols. The remediation was performed prior to the current ATCT inspection program. |

**Air Traffic Control Tower (ATCT)
Mold/Water Incursion Inspections
Listing of Documents Reviewed Continued
Page 15**

| Tab Number | Document Name and Date | Document Type | Author | Recipient | Description |
|-------------------|--|----------------------|--|------------------|---|
| 27 | Report on Exterior Envelope and HVAC Conditions – Kansas City International Airport and TRACON Base Building Airport Traffic Control Tower | Report | DMJM H&N AECOM | FAA | Document details a water intrusion, HVAC, and IAQ inspection at the MCI TRACON and ATCT. Water damage due to leaks in the building envelope and high humidity are discussed. Recommendations are provided for repairs. This inspection was performed prior to the current ATCT inspection project. |
| 28 | Mold and Moisture Assessment – Corpus Christi, Texas Airport Traffic Control Tower | Report | Barbara Herbert NISC, CIH Texas Dept. of Health Services Mold Assessment Consultant | Unknown | Document is a report detailing a mold and moisture assessment at the CRP ATCT and base building. Water damage and fungal growth were identified in some areas. Recommended remedial actions are included in the report. This assessment was performed prior to the current ATCT inspection program. |

**Air Traffic Control Tower (ATCT)
Mold/Water Incursion Inspections
Listing of Documents Reviewed Continued
Page 16**

| Tab Number | Document Name and Date | Document Type | Author | Recipient | Description |
|-------------------|--|----------------------|---|---|--|
| 29 | Corpus Christi ATCT Mold & Moisture Engineering Analysis | Report | Ed Winkler Civil Engineer Infrastructure Support Center – Kansas City | Richard Beyer Acting Supervisor Infrastructure Support Center – Kansas City | Document is a report detailing an inspection of the CRP ATCT and base building following the assessment reported in the previous document. Water damage, fungal growth, and suspected sources of water intrusion were documented. Recommended remedial actions and cost estimates are also included. This inspection was performed prior to the current ATCT inspection program. |
| 30 | Trip to St. Louis ATCT and base building to evaluate leaks and investigation for mold growth | Trip Report | Ed Winkler ACE-472 | Steve Rethmeyer Supervisor, Engineering Support, ACE-472 | Document is a report detailing an inspection of the STL ATCT. Water damage, fungal growth, and suspected sources of water intrusion were documented. Recommended remedial actions and cost estimate are included. This inspection was performed prior to the current ATCT inspection program. |

**Air Traffic Control Tower (ATCT)
Mold/Water Incursion Inspections
Listing of Documents Reviewed Continued
Page 17**

| Tab Number | Document Name and Date | Document Type | Author | Recipient | Description |
|-------------------|---|----------------------|--|------------------|--|
| 31 | Microbiological Remediation for FAA St. Louis Airport Traffic Control Tower | Statement of Work | FAA | Contractors | Document is a specification developed for a mold remediation project at the STL ATCT. The remediation was performed prior to the current ATCT inspection program. |
| 32 | OST Recommendations Tracking Sheet | Correspondence | OST | FAA | Document lists OST recommendations, the FAA response action, completion deadline, and the current status of each action. The sheet contained a recommendation to perform water damage assessments at other Leo Daly ATCTs. |
| 33 | Civil Action Number 07cv0983 (ESH) | Legal Ruling | Ellen Segal Huvelle U.S. District Judge | Public Record | Document is a court ruling involving two Washington, D.C. residents that sued an apartment complex for mold exposure. An expert witness in the case, Dr. Ritchie Shoemaker, was disqualified in a court proceeding. Dr. Shoemaker is |

**Air Traffic Control Tower (ATCT)
Mold/Water Incursion Inspections
Listing of Documents Reviewed Continued
Page 18**

| Tab Number | Document Name and Date | Document Type | Author | Recipient | Description |
|-------------------|--|----------------------|---------------|---------------------------|---|
| | | | | | quoted in other documents reviewed. |
| 34 | ATO-Terminal ATCT & TRACON Facility Design Types – Executive Reference Guide | Reference Guide | FAA | FAA Personnel Contractors | Document is a guide containing definitions of terminal facility design types, the evolution of these designs, the number of such facilities, estimated maintenance costs. This document provides a history and the design characteristics of the Leo Daly design ATCTs. |

**Air Traffic Control Tower (ATCT)
Mold/Water Incursion Inspections
Listing of Documents Reviewed Continued
Page 19**

List of Acronyms

| | |
|-------|---|
| DHHS | U.S. Department of Health and Human Services |
| DOL | U.S. Department of Labor |
| DOT | U.S. Department of Transportation |
| FAA | Federal Aviation Administration |
| FOH | Federal Occupational Health |
| NATCA | National Air Traffic Controllers Association |
| NIOSH | National Institute for Occupational Safety and Health |
| OSHA | Occupational Safety and Health Administration |
| OST | Office of the Secretary of Transportation |
| PHS | U.S. Public Health Service |
| CRP | Corpus Christi Airport |
| DTW | Detroit Metropolitan Wayne County Airport |
| STL | St. Louis Airport |
| MCI | Kansas City International Airport |
| ATCT | Air Traffic Control Tower |
| HVAC | Heating, Ventilation, and Air Conditioning |
| IAQ | Indoor Air Quality |

1

**INVESTIGATION OF MOLD AND MOISTURE AT THE
FEDERAL AVIATION ADMINISTRATION
DETROIT METROPOLITAN AIR TRAFFIC CONTROL TOWER FACILITY**

July 15, 2008

EXECUTIVE SUMMARY

The scope and objective of this investigation was to determine whether there continues to be mold and moisture problems at the DTW air traffic control tower as alleged by the whistleblowers, and if so, to determine the appropriate remedial actions that FAA should take to resolve this problem. The whistleblowers specifically allege that:

1. FAA's attempts to remediate the mold and eliminate moisture sources in the tower have been insufficient.
2. Union requests to perform invasive testing within wall cavities and observations behind wallboard panels surrounding the tower elevator shaft have been denied by FAA.
3. There is direct evidence that mold is still in the facility and that the moisture problem in the building has not been sufficiently corrected; FAA has placed pans and buckets above drop ceilings to catch water that is intruding into the building.

As discussed below, our investigation has substantiated the whistleblowers' allegations that there continues to be a mold and moisture problem at the facility and that, although FAA has made significant efforts to remediate the mold and moisture intrusion, it has not followed through on several key recommendations to correct this ongoing problem. Based on the site observation, review of documentation and results of bioaerosol fungal spore air monitoring, we found:

- Inspections of tower wall cavities on the outside of the elevator shaft revealed apparent mold growth on the 9th and 4th floors.
- Visible mold was discovered on new drywall that had been installed in the remediation area in room 928 of the tower. Additionally, visible mold was observed on the back side of the green wallboard elevator shaft inside the wall cavity in 928. The mold appeared to be related to moisture wicking up the new drywall that was in contact with the concrete floor slab. The amount of visible mold was small, less than 10 square feet.
- A very small amount of visible mold was also observed in room 428 on the green wallboard elevator shaft inside the wall cavity. No visible mold was observed in the new drywall that was installed in the remediation area in room 428. The amount of visible mold was small, less than 10 square feet.
- In many areas of the tower, drywall is in direct contact with the concrete floor surface.
- The base building roof is leaking badly in several areas. Catch pans and a funnel were observed above the drop ceiling in an attempt to catch rain water and snow melt that is entering the building.
- Approximately 20 stained ceiling tiles were observed to have been recently removed from the facility. These tiles had become wet from base building roof leaks. FAA management indicated that stained/wet ceiling tiles are removed and replaced as a part of routine maintenance.
- The measured airborne fungal spores detected within the facility does not indicate elevated mold spore concentrations.
- The spore *Stachybotrys* was detected within unoccupied areas of the facility, but not in outside air samples. *Stachybotrys* is a mold spore that is not commonly found indoors and is an indicator of chronic moisture intrusion.
- Other measured air quality data for temperature, relative humidity, carbon monoxide, carbon dioxide, and airborne particles did not reveal any indicators of poor indoor air quality.

- A review of employee injury and illness data revealed 15 employees sustained injuries or illnesses related to mold, indoor air quality, or respiratory illness in 2005 and 2006.
- There does not appear to be ongoing employee injuries or illnesses due to mold, indoor air quality, or respiratory issues. The most recent case related to mold or air quality was reported almost 2 years ago, on July 24, 2006.
- Some past recommendations submitted by outside agencies and consultants have been completed; however many of the items are still considered incomplete or in progress. Most importantly, moisture and condensation problems continue to remain at the facility. Areas where previous mold growth had occurred and been remediated were observed to have moisture intrusion and visible mold growth again. See Appendix A of this report for greater detail on the status of past recommendations.
- FAA failed to perform a detailed inspection of wall cavities within the air traffic control tower or allow the union to conduct wall cavity inspections of the elevator shaft walls. Subsequent wall cavity inspections performed as part of this investigation did indeed reveal visible mold. Such inspections should have occurred at the facility years earlier.

As detailed later in this report, our recommendations to FAA include:

- Perform a comprehensive inspection of the tower's elevator shaft and wall cavities on all floors to determine the full extent of the moisture and mold problem.
- Remove any identified mold and molded porous materials that are discovered and develop a communication plan and safety control plan to be shared with employees working within the facility. Removal of molded materials shall be conducted in a safe and controlled manner, similar to asbestos abatement and in accordance with the Environmental Protection Agency's *Table 2: Guidelines for Remediating Building Materials with Mold Growth Caused by Clean Water* <http://www.epa.gov/mold/table2.html>
- Remove all unnecessary wall board and porous materials from the unoccupied areas of the air traffic control tower. These materials may become a food source for mold should they become wet. If wallboard must be reinstalled for fire rating reasons, investigate using paperless wallboard, cement backer board, or mold resistant drywall. Drywall surfaces shall not be in direct contact with the concrete floor deck and shall have a ½ inch gap.
- Monitor the facility for moisture intrusion, mold growth, and condensation. Utilize the data from the temperature and humidity sensors that have been installed in the elevator shaft and tower rooms to determine if condensation is occurring. Make corrective action to prevent such occurrences and stop moisture intrusion into the structure.
- Replace the leaking base building roof and develop a communication and safety control plan to be shared with all employees at the facility.
- Review FAA's policies to ensure that employees are encouraged to report work-related medical and health issues. Management should create an environment that promotes the prompt reporting work-related injuries, illnesses and health symptoms and openly support the taking of approved sick leave when necessary in accordance with FAA's policies and union agreements. FAA should conduct an employee health symptom survey to provide an opportunity for employees at the facility to openly express their health and medical symptoms without fear. A follow-up survey should be conducted after the mold

remediation and moisture problems have been corrected to document if employee health problems have improved.

- Evaluate other FAA air traffic control towers of similar Leo Daly design and construction to determine if they have similar moisture and mold growth problems.

METHODOLOGY

The investigative team from the Office of the Secretary of Transportation (OST), consisted of the Departmental Safety and Occupational Health Manager (CIH), a senior attorney from the Office of General Counsel and a contract Certified Industrial Hygienist. The team investigated the whistleblowers' allegations that the mold and moisture problems at the air traffic control facility have not been fully remediated, that the FAA has denied requests by the Union to perform invasive testing of wall cavities and that moisture is continuing to intrude into the building. The team reviewed documentation received from both the whistleblowers and FAA management, including previous reviews and investigations conducted at the facility by several contractors and government entities including the DOT Office of Inspector General; National Institute for Occupational Safety and Health (NIOSH), the U.S. Public Health Service, Office of Federal Occupational Health (FOH); Department of Labor's Occupational Safety and Health Administration (OSHA). The team also reviewed medical related information received from the whistleblowers and correspondence and reports from the union's expert. The most recent independent review of the FAA's remediation efforts was conducted by an arbitrator who heard grievances filed by the union concerning mold contamination at the DTW facility. The Arbitrator's decision was issued on October 5, 2007. In this decision, the Arbitrator found that "at this point, the Agency has employed every reasonable means of abating the mold and preventing future problems." However, the Arbitrator stated that his conclusion was tentative and that if the mold contamination continued, then it was incumbent on the Agency to make further efforts to remediate the problem.

The investigation also included a site visit on May 19-20 which consisted of meetings with management and interviews with each of the three whistleblowers who were accompanied by a union attorney during their interview. In addition, a site inspection was conducted by the Departmental Safety and Occupational Health Manager and the contract certified industrial hygienist which consisted of a visual inspection of the facility for mold and moisture intrusion and bioaerosol air monitoring for fungal spores. The visual inspection included an invasive inspection of wall cavities using a boroscope, and a visual inspection of the elevator shaft from the roof of the elevator car. Management and union representatives accompanied OST on this site inspection. In addition on May 20, a union expert, among others, also observed the inspection. The industrial hygiene report, including air sampling results and notes and photographs from the visual inspection are appended to this report as Appendix C and D.

BACKGROUND

Visible mold growth was identified in several areas of the Detroit air traffic control tower during a routine inspection on September 28, 2004. The Detroit Metropolitan air traffic control tower is a Leo Daly design, constructed in 1990. The tower is approximately 230 feet tall, with a 3 level base building attached to it to connect to the main terminal. The majority of the tower shaft is

unoccupied areas with no storage inside. There is a central elevator shaft used to transport employees from the base building up to the air traffic control tower cab.

In 2005 and 2006 FAA made efforts to remove the identified mold from the tower structure, seal the structure to prevent additional moisture intrusion, and made modifications to the building's heating, ventilation, and air conditioning system to help improve the air balance, prevent condensation, and create a positive air pressure in the facility. FAA was advised to clean visible mold from the elevator shaft liner using a biocide chemical and on January 22, 2005, employees were evacuated from the facility due to the strong chemical odor. This resulted in 7 employee injury/illness claims reported on that date due to employees suffering respiratory illnesses caused by the elevator shaft cleaning efforts.

Since 2005, numerous agencies and contractors including the Occupational Safety and Health Administration, National Institute for Occupational Safety and Health, and Federal Occupational Health have visited the site or conducted a review of documentation related to the facility and employee health issues. The conclusions of these experts indicated that the building did have evidence of moisture intrusion and mold growth, that employees may be experiencing health effects, and that actions were necessary to stop moisture from entering the facility, that visible mold needed to be remediated, and that improvements must be made to the building's heating, ventilation, and air conditioning systems to prevent moisture condensation.

During that time, the union was prevented from conducting intrusive wall cavity inspections or conducting air monitoring and industrial hygiene samples within the facility. The Office of the Inspector General also conducted an inspection of the facility and released a report of their findings on July 11, 2006, recommending that FAA alleviate the source of moisture, finding that until the moisture sources had been controlled, mold will continue to be an ongoing problem. Employees at the facility claim that they still suffer mold related respiratory illnesses and that the facility continues to suffer from moisture intrusion and mold problems.

STATUS OF PAST RECOMMENDATIONS

Several agencies and consultants have inspected the facility or reviewed documentation regarding the mold and moisture problems at the Detroit Air Traffic Control Tower. The key recommendations focused on:

1. Sealing the building envelope to prevent moisture from entering the building.
2. Making improvements to the building's heating, ventilation, and air conditioning systems to prevent condensation within the facility.
3. Removing areas of visible mold growth and remediating areas of the facility.
4. Preventing wicking of moisture into wallboard surfaces by having at least a 1/4" gap above tower floor slab surfaces.
5. Removing materials that could become food sources for mold from the tower.
6. Conducting ongoing inspections of the facility for moisture and mold growth.

While FAA has made progress to implement the corrective actions, many key expert recommendations remain incomplete. FAA has sealed the tower structure to prevent moisture

intrusion, reconfigured and improved the tower's ventilation systems to help prevent condensation and removed mold and molded materials from areas where it was found. However, several improvements and moisture control recommendations from the 2005 Jacobs Engineering Moisture Assessment Report remain incomplete. For a time FAA did conduct inspections of the elevator shaft for the return of moisture and mold growth, but these inspections have stopped. Moisture and leaks are still entering the facility from the base building roof, wall board surfaces are still contacting the concrete floor slab in unoccupied levels of the control tower, and the condensation and moisture problem continued allowing the return of mold growth on the 9th and 4th floors. Furthermore, at the time of our site visit FAA installed a "memory card" into the HVAC controls to activate the humidity and temperature sensors within the building. It is unclear why these sensors were not activated sooner, seeing their importance in monitoring the temperature and humidity levels in the tower to help identify and prevent condensation. The attached Appendix A of this report lists the status of the past expert recommendations submitted to FAA.

WHISTLEBLOWER EMPLOYEE INTERVIEWS

Former and current Air Traffic Control Specialists Vincent Sugent, Elizabeth Dale, and David Parker were interviewed as part of the investigation to obtain a clear understanding of their health symptoms and concerns regarding mold and moisture at the facility. The whistleblowers stated that as air traffic controllers they work 8-10 hour shifts inside the air traffic control tower cab. The majority of their time is spent directly at the top of the tower in the cab area, or one level below within the Junction Level break room. The employees attend meetings or visit other levels of the base building for short periods of time as necessary.

The three whistleblowers reported experiencing similar health symptoms such as: respiratory illnesses, asthma, laryngitis, headaches, coughs, elbow pain, sneezing, and short term memory loss. The whistleblowers have all sought medical treatment for their health issues and report some level of improvement. Two of the individuals have been through a treatment plan using the medication cholestyramine. None of the whistleblowers indicate that they had previous allergies or have been tested to see if they are allergic to mold. They do report to have ongoing health problems and may be sensitized to mold spores that they would experience within the facility, or elsewhere.

Each of the whistleblowers expressed concern with the thoroughness of the efforts that FAA has taken to remove mold from the facility and prevent moisture leaks. They claim that mold is still present within the facility and that it needs to be properly removed. All three individuals stated they believe other FAA employees working at the facility are experiencing similar health problems, but do not report their symptoms for fear of losing their jobs. FAA's air traffic controllers must complete an annual medical evaluation and report any health symptoms and medications that they are taking. The whistleblowers indicate that local FAA management issued a memorandum that employees are not to abuse sick leave and that air traffic controllers are hesitant to use sick leave or report all of their health problems during their annual medical evaluations.

EMPLOYEE INJURIES AND ILLNESSES

OSHA Form 300A, Summary of Work-Related Injuries and Illnesses for the Detroit air traffic control tower were obtained and reviewed for trends. Approximately 160 employees work at the facility, 135 are air traffic controllers and 35 are technical operations employees. See Appendix B for a detailed breakdown of employee illnesses and injuries.

| Year | Number of Employee Injuries and Illnesses | Percent of Total |
|------------------------|---|------------------|
| 2004 | 4 | 14.8% |
| 2005 | 12 | 44.4% |
| 2006 | 7 | 30.0% |
| 2007 | 2 | 7.4% |
| 2008 (1/01/08-6/23/08) | 2 | 7.4% |
| Total | 27 | 100% |

The following trends were noted with FAA employees working at the facility.

- Since January 1, 2004, 27 total injuries and illnesses have been reported at the Detroit Air Traffic Control Tower. 74.4% of the cases occurred in 2005 and 2006.
- Since January 1, 2004, 56% of the reported employee injuries and illnesses appear to have been related to poor indoor air quality, mold, or respiratory illness. These cases all appear to have occurred in 2005 and 2006 during the majority of mold remediation efforts that were conducted within the facility.
- Employees were not reporting cases related to indoor air quality, mold, or respiratory illness prior to 2005, or in 2007 and 2008.
- 2004 - No reported employee injuries or illnesses related to indoor air quality, mold, or respiratory illnesses.
- 2005 - 12 employee illnesses related to indoor air quality, mold, or respiratory illness. 100% of cases were air traffic controllers. 58% of the cases were directly related to the January 22, 2005 attempt to clean mold from surfaces of the elevator shaft using a biocide chemical.
- 2006 - 3 employee injuries/illnesses were possibly related to air quality or mold in the facility. These air traffic controllers had skin rashes, difficulty breathing, or eye irritation and swelling.
- 2007 - No employee injuries or illnesses related to indoor air quality, mold, or respiratory illnesses.
- 2008 (January 1, 2008 - June 23, 2008) - One TRACON employee became ill due to fumes and odors from a computer electrical fire. No employee injuries or illnesses related to mold or respiratory illnesses were recorded.

Based on the injury and illness data reviewed, FAA employees working at the Detroit air traffic control tower did experience respiratory illnesses related to indoor air quality in 2005 and 2006. The majority of these cases were directly related to chemical odors from elevator shaft cleaning efforts that took place on January 22, 2005. Injury and illness data from 2007 and 2008 indicates that FAA employees have not reported experiencing injuries and illnesses related to poor indoor air quality. The most recent case related to mold or air quality was reported on July 24, 2006, so

there has been no new related case for 2 years. This could be an indicator that air quality within the facility has not caused new respiratory illness cases in 2007 and 2008. The possibility does exist that air traffic controllers are not reporting air quality or mold related cases due to fear that they could lose their jobs. The whistleblowers claimed that air traffic controllers are reluctant to report certain health symptoms and medications they are using for fear of not passing their medical clearance examinations. It is noted that the Federal worker's compensation system is designed as a no fault system to protect Federal employees that sustain work related injuries or illnesses. Based on the review of employee injuries and illnesses, whistleblower interviews, and direct observation of conditions with the Detroit air traffic control tower and base building, this investigative team is in agreement with the findings in the July 24, 2006, health hazard evaluation by the National Institute for Occupational Safety and Health (NIOSH), which states:

"When considered collectively, the various reports and documents provided to NIOSH describe a situation whereby leaks in the building envelope had allowed water to enter the ATCT, wick into drywall, and create a suitable substrate for mold growth. Mold contamination on drywall resulted in employees' health concerns. This situation has existed since sometime in 2004 (possibly earlier), and can be expected to continue or recur until all leaks have been repaired, HVAC deficiencies corrected, and all mold sources located and successfully remediated. Until this remediation takes place, the employees who experience upper airway symptoms when exposed to mold may continue to experience them."

FINDINGS

1. The visual inspection conducted on May 19 and 20 revealed that the mold and moisture problems at the DTW air traffic control facility have not been fully remediated. Specifically, we found:

- Inspections of tower wall cavities on the outside of the elevator shaft revealed apparent mold growth on the 9th and 4th floors. ¹
- Visible mold was discovered on new drywall that had been installed in the remediation area in room 928 of the tower (both in the external tower wall and elevator shaft wall cavities). Additionally, visible mold was observed on the back side of the green wallboard elevator shaft inside the wall cavity in 928. The mold appeared to be related to moisture wicking up the new drywall that was in contact with the concrete floor slab. The amount of visible mold was small, less than 10 square feet.
- A very small amount of visible mold was also observed in room 428 on the green wallboard elevator shaft inside the wall cavity. No visible mold was observed in the new drywall that was installed in the remediation area in room 428. The amount of visible mold was small, less than 10 square feet.
- In many areas of the tower, drywall is in direct contact with the concrete floor surface.
- The base building roof is leaking badly in several areas. Catch pans and a funnel were observed above the drop ceiling in an attempt to catch rain water and snow melt that is entering the building.

¹ On June 9-12, 2008, FAA conducted its own inspection of the Detroit air traffic control tower wall cavities and has identified additional locations that have mold contamination.

- Approximately 20 stained ceiling tiles were observed to have been recently removed from the facility. These tiles had become wet from base building roof leaks. FAA management indicated that stained/wet ceiling tiles are removed and replaced as a part of routine maintenance.
- A visual inspection of the tower elevator shaft revealed no visible mold growth. Areas where past cleaning had been completed were evident. There was visual evidence of past moisture tracking down the shaft wall. No moisture or condensation was observed in the elevator shaft at the time of the inspection. The shaft did not appear to be a conduit or active pathway for mold spores to travel within the facility. Notes and photographs from the visual inspection are contained in Appendix C.

2. Air Monitoring Results revealed that indoor fungal concentrations were insignificant when compared to concentrations outdoors. Stachybotrys spores were detected on the ninth and fourth unoccupied levels. The Stachybotrys spores are significant in such that they are an indicator that the tower has had a chronic moisture control problem.

Bioaerosol samples were collected at two base building locations, five tower locations, and outdoors for comparison. The sampling was conducted at two different time periods on May 20, 2008, beginning at approximately 8:30AM and 11:30AM. The concentrations of airborne fungal spores detected was considered insignificant and do not indicate elevated mold spore concentrations within the facility.

The fungus *Stachybotrys* was detected on the 9th and 4th floors of the air traffic control tower and was likely detected in these areas due to the wallboard panels that were removed and visible mold that was discovered. *Stachybotrys* is a mold spore that is not commonly found indoors and is an indicator of chronic moisture intrusion. *Stachybotrys* produces a sticky spore that is not easily airborne, unless disturbed. Mold spore concentrations within the air traffic control tower cab were observed to be much lower than mold spore concentrations found outdoors. This is a good indicator that the building's ventilation systems are properly filtering out mold spores. The elevator shaft itself does not appear to be an effective conduit to spread mold spores throughout the air traffic control tower. Higher spore concentrations were found on the 9th and 4th floors of the tower, in areas where we disturbed molded drywall materials. If the tower elevator shaft were effective in disbursing fungal spores, higher concentrations of mold spores would have been evident in the tower cab, Junction level break room, or inside the base building. Likewise, if the elevator shaft was an effective pathway for mold spores to spread, it could be concluded that the disturbed *Stachybotrys* spores would have spread to other floors or other areas of the facility. Spread of *Stachybotrys* spores was not observed or concluded from the air monitoring results. While the finding of *Stachybotrys* spores is significant because it is an indicator that there is or has been a chronic moisture problem in the tower, it does not pose a health hazard more than any other mold or fungal spore that individuals can become sensitized to.

Mold spore and air quality measurements were collected in the following locations:

- Air Traffic Control Tower Cab
- Junction Level (Break Room, and Debriefing Room)
- 10th Floor. Room 1028 (former Union office)
- 9th Floor. Room 928

- 4th Floor. Room 428
- 2nd Floor, Base Building. TRACON Radar Room 212
- 1st Floor, Base Building. Open area outside of Room 109
- Outside – On top of 2nd Floor Base Building near air intakes.
- Outside – On ground level of Base Building near air intakes.

Other measured data for temperature, relative humidity, carbon monoxide, carbon dioxide, and airborne particles did not reveal any indicators of indoor air quality problems. All recorded measurements were within legal, regulatory limits and within or insignificantly below ASHRAE recommended ranges. Detected airborne particle counts were insignificant for each size range and not significant when compared to outdoor levels. The industrial hygiene report and air sampling results are contained in Appendix D.

RECOMMENDATIONS

By October 1, 2008, the Administrator of the Federal Aviation Administration shall provide a written response to the Secretary of Transportation for each of the recommendations submitted below. Written responses shall include actions the agency has taken to comply with the recommendation and list the dates that such corrective actions were completed.

Air Traffic Control Tower Mold / Moisture Recommendations

- A. **Conduct a comprehensive inspection of the wall cavities on every floor of the air traffic control tower, making sure to inspect the wall cavity from the unoccupied room side of the elevator shaft.** The inspection should look for evidence of mold contamination, condensation, and moisture intrusion.

- B. **Based on the comprehensive inspection, remove all visibly contaminated (molded and water damaged porous materials) from the air traffic control tower.** Non porous substrates (such as metal studs or concrete materials) can be cleaned to remove visible mold growth. Do not use a biocide to clean the materials. Dispose of and replace building materials necessary. Place a sticky sided contact paper on top of visible mold to minimize the chance of mold spores becoming airborne during removal. Wallboard materials should be cut out 18 inches beyond the edge of where visible mold growth and water damage was discovered. The remediation of the mold and water damaged materials must be conducted in a similar manner as asbestos abatement. This would include setting up plastic sheeting and a negative-air machine equipped with HEPA filtration to contain and filter any airborne fungal spores that are released during cleanup. A written safety control plan for the mold remediation shall be developed to identify and control any safety hazards associated with the remediation work. Strong consideration should be given to conducting the remediation work at night to minimize the number of potential employees impacted. Care should be taken to at a minimum adhere to the Environmental Protection Agency's *Table 2: Guidelines for Remediating Building Materials with Mold Growth Caused by Clean Water*
<http://www.epa.gov/mold/table2.html>.

- C. Develop a mold remediation project communication plan for the facility to improve communication efforts between FAA management and union employees.** Items such as memorandums and safety meetings are needed to educate employees about the mold discovered within the air traffic control tower and the safety control efforts that will be implemented to remedy the conditions. These meetings will provide employees an opportunity to voice their concerns, and allow FAA management to demonstrate that efforts are being implemented to ensure the safety and health of all working within the facility.
- D. Remove all unnecessary wallboard and carpeting from unoccupied areas of the air traffic control tower.** Wallboard necessary to maintain the required fire ratings may be left in place. Remove any wallboard currently in contact with concrete floors in the unoccupied levels of the air traffic control tower. New wallboard materials that are installed must have at least a one half inch gap from the concrete floor slab or be provide with a strip of silicone caulking at the concrete/wallboard junction to prevent condensation and/or moisture intrusion from wicking into the wallboard.
- E. Evaluate the fire rating of cement backer board and mold resistant / paperless wallboard.** Use such materials as a substitute for the removed paper faced wallboard in the air traffic control tower. Wallboard with paper could act as a future food source for mold, should condensation or moisture intrusion return.
- F. Continue efforts to prevent moisture intrusion into the air traffic control tower and prevent condensation from forming.** Implement the recommendations that were submitted to FAA within the Jacobs Engineering moisture assessment report dated August 31, 2005. This report recommends HVAC improvements and moisture control items that were still not implemented at the date of our 5/19-20/2008 investigation. Such uncompleted recommendations include:
1. Installing a cooling coil into the ductwork to remove moisture from the outside air that is brought into the building.
 2. The bottom edge of gypsum wallboard should be cut back approximately ¼" above the floor slab to prevent wicking or moisture into the panel. An appropriate fire rated sealant should be installed between the slab and gypsum wallboard.
 3. Eliminate situations where moist, warm air is allowed to contact cool surfaces.
 4. Recommend removal of the drywall from all the "storage" rooms in the tower.
- G. Actively monitor moisture levels in the elevator shaft and unoccupied areas of the air traffic control tower and implement corrective actions as necessary.** Use the data collected from the temperature and relative humidity sensors that have been installed in the elevator shaft and unoccupied areas of the tower to identify places of differing temperature and relative humidity. Large fluctuations of temperature and relative humidity levels between the elevator shaft and unoccupied areas of the tower, could cause condensation on wall surfaces or lead to condensation on hot/cold water lines or heating and cooling ductwork.

- H. **Review the policies at FAA's Detroit air traffic control tower to ensure that employees are encouraged to report work-related health and medical problems.** Management should create an environment that promotes the prompt reporting of work-related injuries, illnesses and health symptoms and openly support the taking of approved sick leave when necessary in accordance with FAA's policies and union agreements.
- I. **Conduct an employee health symptom survey to provide an opportunity for employees working at the facility to openly express their health and medical symptoms without fear.** This survey should be conducted by an agency independent of the FAA, such as NIOSH, Federal Occupational Health, or a local occupational health clinic. This survey may be useful in identifying groups of ill employees working in an identical location, or with similar health symptoms. As a result of the survey, any employees expressing health symptoms should be encouraged to seek medical attention from an appropriate physician. A follow-up health survey should be conducted after the mold remediation and moisture problems have been corrected to document if employee health problems have improved. Ideally, there should be a correlated reduction in employee health symptoms after mold and moisture have been removed from the facility.
- J. **Evaluate other FAA air traffic control towers for mold and moisture infiltration problems.** The Detroit Metropolitan Airport air traffic control tower is of a Leo Daly design. FAA operates other Leo Daly designed towers of similar construction and characteristics. It is prudent for FAA to inspect these other towers to determine if similar mold and moisture problems exist at those facilities. FAA shall report back to the Secretary of Transportation in writing with their findings at other tower facilities by October 31, 2008.

Base Building Roof Moisture Recommendations

- K. **Replace the leaking base building roof.** Ensure adequate control measures are in place (such as de-energizing air handlers and sealing outside air intakes) to safely prevent infiltration of airborne chemical contaminants from outside the building. A thorough pre-construction survey and written safety control plan shall be conducted to identify any ways that the roofing project could negatively impact FAA employees working within the air traffic control tower or base building. Strong consideration should be given to conducting the roof replacement during night hours so as to impact as few FAA employees as possible. If TRACON workers may be negatively impacted, consider moving such operations to a temporary alternate location while the roofing repairs are being made.
- L. **Continue to immediately remove and replace water damaged building materials as necessary.** Items such as wet and stained ceiling tiles, insulation, and wallboard must be promptly removed so as not to provide a food source for mold growth. When water damaged materials are discovered, an investigation shall be made to identify the moisture source and correct it.

M. Develop a roof project communication plan for the facility to improve communication efforts between FAA management and union employees. Items such as memorandums and safety meetings are needed to educate employees about the roof replacement project and the safety control efforts that will be implemented throughout the project. These meetings will give employees an opportunity to voice their concerns, and allow FAA management to demonstrate that efforts are being implemented to ensure the safety and health of all working within the facility.

2

APPENDIX A: SUMMARY OF PAST RECOMMENDATIONS

6/13/2007

Applied Environmental, Inc.

1. Remain vigilant for any new cases of water leakage or incursion events. Take prompt action to assess and dry affected materials. *Status - Incomplete. Prompt action has not been taken to repair the leaking base building roof. Action has been taken to seal the joints and exterior of the tower structure and cab.*
2. Promptly investigate and correct the source of moisture and staining and replacing ceiling tiles in a timely manner. *Status - Incomplete. Ceiling tiles are replaced, but there has been a delay in repairing the base building roof leaks.*
3. Establish a routine inspection of the elevator shaft (on at least a yearly basis) to assure that water incursion and/or mold growth is not present. *Status - Incomplete. At one time FAA performed frequent inspections of the elevator shaft for water incursion and mold growth. FAA has since stopped the process after finding that mold and moisture did not recur.*

7/11/2006

Office of the Secretary of Transportation, Office of Inspector General

1. The FAA Administrator provide the requesting Members of Congress and the OIG with a list of the planned actions to complete mold remediation efforts and alleviate moisture infiltration at the facility and include the expected completion date for each project. *Status - Complete. The FAA provided the members of Congress with letters listing the planned actions to complete the mold remediation and moisture infiltration. Letters were sent on January 3, 2007.*²

6/24/2006

National Institute for Occupational Safety and Health

1. Inspect all locations where building materials may have become wet. Mold that is not actively growing can still present a hazard, and may resume growing when conditions become favorable. *Status - Incomplete. At the time of the survey, FAA had not performed wall cavity inspections in the walls surrounding the tower elevator shaft. Since mold was previously identified the 3rd, 4th, and 9th floors of the tower, it could be reasoned that conditions for mold and moisture could be found on other floors.*
2. Perform corrective actions recommended in the Jacobs Engineering Group report to help ensure that all sources of moisture are eliminated and the HVAC system operates properly. *Status - Incomplete. All recommendations from the Jacobs Engineering Report have not been completed. Not all wallboard has been replaced from the unoccupied tower rooms, wallboard is still touching the concrete floor deck, and a cooling coil has not been installed to take moisture out of air that is brought into the building's outside air intakes.*

6/19/2006

U.S. Department of Labor, Occupational Safety and Health Administration

² The OIG found that the FAA had taken actions to remove mold from the facility, but not alleviate the sources of moisture causing mold growth.

1. Eliminate all sources of water intrusion into the facility. Damp or wet building materials and furnishings should be cleaned and dried within 24-48 hours to prevent the growth of mold. *Status – Incomplete. Exterior sealing/caulking of the tower was completed November 2, 2006. The base building roof leaks badly and is in need of replacement.*
2. Maintain and operate the outside air ventilation system in accordance with design specifications. Provide 500 cfm of outside air to the cab and keep the cab under positive pressure through proper maintenance and operation of air handler numbers 13 and 14. All HVAC systems should be operated to keep the facility under positive pressure to prevent infiltration of unconditioned air. Pressurizing the lower floors will help minimize the stack effect in the elevator shaft and middle tower area. *Status – Complete. HVAC modifications completed February 2007 and FAA indicates the facility is at a positive pressure.*

5/05/2006

Federal Occupational Health

1. Continue to document and map all moisture intrusion events. *Status – Complete and ongoing.*
2. On occurrence of moisture intrusion, determine and correct the source of moisture infiltration. Abate any affected areas following properly developed and approved procedures using qualified and environmentally trained personnel. *Status – Incomplete. The leaking base building roof has yet to be replaced and repaired.*
3. Monitor and oversee all future fungal abatement activities from development to completion with proper documentation. *Status – Ongoing.*
4. Utilizing a HEPA vacuum, vacuum all surfaces within the elevator shaft under negative pressure and monitor for new occurrence of fungal growth. Should the decision be made to encapsulate these walls, verify any product used to assure that the integrity and “Fire Rating” status of the walls is not compromised. *Status – Completed 6/26/2006.*
5. Educate and inform employees of ongoing fungal abatement activities within the facility. *Status – Incomplete. Communication between FAA management and employees is strained. A large amount of distrust between both groups was observed. Additional efforts need to be made to bridge the communication and trust gaps.*
6. Investigate the facility link between the terminal and the FAA to determine the +/- pressure effect to the FAA. *Status – Complete. 2/2007 there was a positive pressure established in the FAA facility compared to the Terminal Building.*
7. Inspect and repair all expansion joint for failing caulking. Review data on replacement materials to ensure proper materials are utilized in repair efforts. *Status – Complete. Structure wall panels and caulking were replaced and building sealed to prevent moisture intrusion.*
8. Correct gypsum wallboard in contact with decking floor that would allow a “wicking” to occur should gross moisture intrusion occur. *Status – Incomplete. Wallboard is still in direct contact with the floor in many areas.*
9. To reduce the potential for microbial growth in the facility, the relative humidity should be adjusted and maintained within the ASHRAE recommended range of 30% to 60%. *Status – Complete. Temperature and relative humidity sensors were activated in the elevator shaft and tower floors on 5/19/2008. The documented average relative humidity levels during the site survey was within or insignificantly below the ASHRAE recommended range of 40%-60% for summer.*

8/31/2005

Jacobs Engineering – Moisture Assessment Report

1. All non-rated internal partitions and associated doors, frames, and hardware within the tower shaft should be removed. *Status – Complete. Doors and combustible items removed from unoccupied floors of the tower.*
2. The bottom edge of gypsum wallboard should be cut back approximately ¼” above the floor slab to prevent wicking of moisture into the panel. An approved, fire rated sealant should be installed between the slab and gypsum wallboard. A rubber vinyl wall base should also be installed to conceal the cut. *Status – Incomplete. Wallboard is still touching the floor slab in many areas of the tower.*
3. The shaft liner panels within the elevator shaft should be wet-wiped, cleaned, and may be painted. *Status – Complete. The shaft cleaning was completed on 5/26/2006.*
4. All vertical exterior pre-cast panel joints should have the sealant joints stripped, and appropriate new backer rod and sealant installed. *Status – Complete. The exterior caulking and sealing of the tower was completed on 11/2/2006.*
5. The concrete decks should have a fluid applied waterproof traffic membrane installed. *Status – Complete. The exterior caulking and sealing was completed on 11/2/2006.*
6. Reactivate the vestibule ventilation system and install a cooling coil into the ductwork to remove the moisture from the outside air. Put the tower under positive pressure to prevent untreated moisture and dust laden air entering into the facility. *Status – Incomplete. It is our understanding that a cooling coil has not been installed to remove moisture from outside air that is draw into the facility. Work has been done to bring the HVAC systems into compliance with ASHRAE guidelines.*
7. The entire HVAC system needs to be rebalanced to provide positive pressure at all times. *Status – Complete. 2/2007 there was a positive pressure established in the FAA facility compared to the Terminal Building.*
8. Close the air gap under the door to the ESD’s area. Presently unconditioned moisture laden outside air enters to the ESD’s control room increasing the loads on the newly installed AHU. *Status – Unknown. Improvements to the building HVAC system such as digital controls for the valves, balancing of the air flow, duct cleaning and changes in the make-up air have been performed. Further evaluation of the ATCT temperature/humidity conditions is being conducted prior to implementing further changes.*
9. Recommend removal of the drywall from all the “storage” rooms in the tower. *Status – Incomplete. Drywall in the unoccupied rooms of the tower is still in place and has not been removed.*
10. Assess mechanical ventilation system and improve operational control. Conduct a full assessment of the HVAC system to identify repairs and upgrades to properly control and operate the building ventilation in the tower. *Status – In Progress. Improvements to the HVAC system such as digital controls for the valves, balancing of the air flow, duct cleaning and changes in the make-up air have been performed. Further evaluation of the ATCT temperature/humidity conditions is being conducted prior to implementing further changes*
11. Conduct routine visual mold inspections. *Status - Incomplete. At one time FAA performed frequent inspections of the elevator shaft for water incursion and mold growth. FAA has*

- since stopped the process after finding that mold and moisture did not recur. Periodic inspections should be resumed and documented.*
12. Clean the interior elevator shaft wall surfaces by wet-wiping with a bleach solution. *Status – Complete. The shaft cleaning was completed on 5/26/2006.*
 13. During periodic inspections, identify sources of moisture and correct to prevent reoccurrence. *Status – Complete. Except for the discontinued elevator shaft inspections, the facility is checked for sources of moisture on an ongoing basis.*
 14. Remove gypsum wallboard where it is in contact with concrete floor to create a minimum 1/4" gap between the concrete floor and wallboard to prevent moisture wicking. *Status – Incomplete. Drywall in the tower is still in contact with the concrete floor.*
 15. Check and evaluate waterproofing at exterior joints, corners, and structure penetrations to prevent water intrusion. *Status – Complete. The exterior caulking and sealing was completed on 11/2/2006.*
 16. Check and ensure all chilled water and exterior drain pipes are properly insulated. *Status – Complete. Pipes and ductwork have been insulated in attempts to control condensation.*
 17. Where there is recurring water damage, check building utilities for leaks or improper installations. *Status – Incomplete but in progress. The leaking base building roof is in the process of being replaced.*
 18. Eliminate situations where moist, warm air is allowed to contact cool surfaces. *Status – Incomplete. Modifications have been made to the building's HVAC system and temperature and relative humidity sensors have been installed in the tower elevator shaft and in some unoccupied rooms of the tower. FAA is monitoring the data obtained from the sensors. The fact that mold has returned in areas where it was previously abated indicates that moisture and condensation problems may remain.*
 19. Maintain floor areas clean by periodic cleaning, and eliminate unnecessary clutter and storage. *Status – Complete. Materials were removed from the unoccupied areas of the tower that were previously used as storage rooms.*

3



**U.S. Department of
Transportation**

Office of the Secretary
of Transportation

Assistant Secretary
for Administration

1200 New Jersey Avenue, SE
Washington, DC 20590

July 21, 2008

MEMORANDUM TO: Robert A. Sturgell
Acting Federal Aviation Administrator

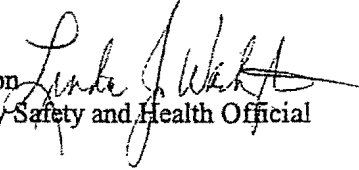
FROM: Linda J. Washington 
Designated Agency Safety and Health Official

SUBJECT: Whistleblower Investigation – Allegations of mold
and moisture problems at Detroit Metropolitan Airport

This presents our investigative findings and recommendations stemming from whistleblower allegations by air traffic controllers at the air traffic control tower at Detroit Metropolitan Airport (DTW) concerning mold and moisture problems at the tower. The whistleblowers allege that despite previous remedial efforts, mold and moisture problems at the tower have not been fully remediated, causing them to continue to experience adverse health effects. Our investigation has substantiated these allegations.

On March 11, 2008, the U.S. Office of Special Counsel (OSC) referred these allegations to the Secretary for investigation and report. The Secretary delegated responsibility for investigating this matter to this office. The whistleblowers are three current and former air traffic control specialists at DTW: Vincent Sugent, Elizabeth Dale, and David Parker. Mr. Sugent and Ms. Dale are currently employed at DTW. Mr. Parker worked as a controller at DTW from June 2002 to July 2005. He was on medical leave from July 2005 to December 2007 when he was terminated for inability to perform the duties of his position.

Please prepare a written response to the recommendations contained within this report by August 8, 2008. Your response will first be sent to the Secretary for approval, and then forwarded to the OSC.

Attachment



**U.S. Department of
Transportation**

Office of the Secretary
of Transportation

Assistant Secretary
for Administration

1200 New Jersey Avenue, SE
Washington, DC 20590

July 21, 2008

MEMORANDUM TO: Robert A. Sturgell
Acting Federal Aviation Administrator

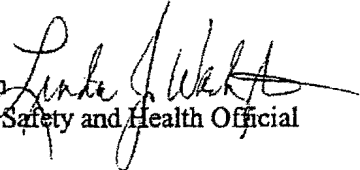
FROM: Linda J. Washington 
Designated Agency Safety and Health Official

SUBJECT: Whistleblower Investigation – Allegations of mold
and moisture problems at Detroit Metropolitan Airport

This presents our investigative findings and recommendations stemming from whistleblower allegations by air traffic controllers at the air traffic control tower at Detroit Metropolitan Airport (DTW) concerning mold and moisture problems at the tower. The whistleblowers allege that despite previous remedial efforts, mold and moisture problems at the tower have not been fully remediated, causing them to continue to experience adverse health effects. Our investigation has substantiated these allegations.

On March 11, 2008, the U.S. Office of Special Counsel (OSC) referred these allegations to the Secretary for investigation and report. The Secretary delegated responsibility for investigating this matter to this office. The whistleblowers are three current and former air traffic control specialists at DTW: Vincent Sugent, Elizabeth Dale, and David Parker. Mr. Sugent and Ms. Dale are currently employed at DTW. Mr. Parker worked as a controller at DTW from June 2002 to July 2005. He was on medical leave from July 2005 to December 2007 when he was terminated for inability to perform the duties of his position.

Please prepare a written response to the recommendations contained within this report by August 8, 2008. Your response will first be sent to the Secretary for approval, and then forwarded to the OSC.

Attachment

4



DEPARTMENT OF HEALTH AND HUMAN SERVICES

Public Health Service

National Institute for Occupational
Safety and Health
Robert A. Taft Laboratories
4676 Columbia Parkway
Cincinnati OH 45226-1998

July 24, 2006
HETA 2006-0004

Wayne Vogelsburg, CIH
Federal Aviation Administration
Great Lakes Region Headquarters
2300 E. Devon Avenue
Des Plaines, Illinois 60018

Dear Mr. Vogelsburg:

Enclosed for your information, is a copy of the closeout letter for the National Institute for Occupational Safety and Health (NIOSH) health hazard evaluation (HHE) at Detroit Metro Tower. The enclosed letter, which describes the findings of the NIOSH investigation, constitutes the final report for this HHE.

Please feel free to call David Sylvain at (508) 997-6126, or Dr. Ayodele Adebayo at (513) 841-4116, if you have any questions regarding the HHE or the enclosed report.

Sincerely yours,

Randy L. Tubbs, Ph.D.
Psychoacoustician
Hazard Evaluations and Technical
Assistance Branch
Division of Surveillance, Hazard
Evaluations and Field Studies



DEPARTMENT OF HEALTH AND HUMAN SERVICES

Centers for Disease Control and Prevention

National Institute for Occupational Safety and Health

U.S. Public Health Service

New England Field Office
P.O. Box 87040
South Dartmouth, MA 02748-0701

July 24, 2006
HETA 2006-0004

Federal Aviation Administration
Attn: Jo L. Tarrh
Director, Central Service Area for Technical Operations
Southwest Region Headquarters
2601 Meacham Blvd.
Fort Worth, Texas 76137-4298

Dear Ms. Tarrh:

On September 30 and October 10, 2005, the National Institute for Occupational Safety and Health (NIOSH) received confidential requests for a health hazard evaluation (HHE) from air traffic controllers at the Detroit Metro Tower. The two requests stated that air traffic controllers and support staff were exposed to mold in the air traffic control tower (ATCT) and ATCT cab at Detroit Metro Airport in Wayne County, Michigan. Health effects listed in the requests include nasal polyps, asthma, rashes, hives, blisters, eye/nose/throat irritation, flu-like symptoms, metallic taste, mood swings, and memory problems. During telephone conversations, several Federal Aviation Administration (FAA) employees stated that they believed mold in the workplace was making them ill. Health effects/conditions reported during these conversations include a constant hacking cough, copious nasal discharge, Chlamydia pneumonia, sinus infections, sore throat, swollen glands, an enlarged uvula, Stachybotrys antibodies in blood samples, and lung scarring. Employees reported that symptoms such as cough, rhinitis, and respiratory difficulties diminished when they were away from the workplace, and increased upon returning to the ATCT.

FAA employees expressed concern about mold on interior and exterior elevator shaft drywall and in various rooms in the tower. They stated that attempts at mold remediation had been ineffective, e.g., the "source" of the mold had not been identified, water leaks had not been repaired, drywall was only partially removed, and new drywall was installed over old drywall. They stated that potentially contaminated drywall in inaccessible exterior locations of the elevator shaft had not been inspected.

In addition to health effects due to mold exposure, requestors were concerned about a specific incident that occurred during a remediation attempt on January 22, 2005. Requestors stated that FAA employees became symptomatic following the spraying of Dri-Eaz Milgo SR® (a commercial deodorizer) in the elevator shaft and on floors 4 and 9. According to information provided by the requestors, FAA employees evacuated the tower after a contractor sprayed the deodorizer. Several FAA employees went to local hospital emergency departments with

Page 2 – Federal Aviation Administration

complaints including eye irritation, headache, upper airway irritation, chest pain, nausea, and bloody nose.

Our evaluation of employees' health concerns consisted of a review of the consultant reports and medical records provided to us. These documents include letters and other documents provided to the National Air Traffic Controllers Association (NATCA) by the union's environmental consultant, Wonder Makers Environmental, Inc., and reports of inspections, sampling, and/or remediation conducted by

- MoldQuest International (bulk sampling results, September 2004)
- Tillotson Environmental Occupational Consulting (site visit, January 22 and 24, 2005)
- DTW Mold Remediation Plan (FAA PowerPoint presentation, March 7, 2005)
- FAA (weekly progress reports for remediation, May 2005)
- Jacobs Engineering Group, Inc. (qualitative moisture assessment, June 21-22, 2005)
- Federal Occupational Health (visual assessment and consultation, February 1, 2006).

This letter describes our findings as they relate to the Detroit Metro Tower. These are: (1) molds are a potential health hazard; (2) sick people working in the building should see their doctor; (3) visible indoor mold should be properly remediated; and (4) sources of moisture in the building should be identified and eliminated to prevent future indoor mold growth.

Information in the documents provided to us indicates that mold was discovered or confirmed as a result of a consultant's inspection on September 29, 2004. The consultation report for this visit stated that mold was visible in at least seven locations on ninth-floor drywall, and was present in three bulk samples. Over the next 9 months, remediation plans were drafted, several consultants inspected the ATCT, and at least two remediation efforts were undertaken. During this period, several FAA employees sought medical attention for conditions they believed were caused by exposure to mold and Dri-Eaz Milgo SR®.

The first remediation for which we have any information, occurred in January 2005, when Coach's Catastrophe Cleaning sprayed Dri-Eaz Milgo SR® on the walls of the elevator shaft, and on floors 4 and 9. This activity resulted in reports of health problems by FAA staff, and in the evacuation of the tower. A bulk sample of Dri-Eaz Milgo SR® was sent to a laboratory that performed a GC/MS head space analysis. The analysis reported the relative abundance of volatile constituents in Dri-Eaz Milgo SR® as "trace," "minor," or "major." The "major" constituents were ethoxymethyl-benzene, 1-octanol, undecane, 1-dodecene, and tridecane. Isopropanol which constitutes 3%-6% of the total ingredients according to the material safety data sheet, was reported as a "trace." Glutaraldehyde, which had been a constituent of one of two Dri-Eaz Milgo SR® formulations (0.3% glutaraldehyde), was not detected. According to information provided by the FAA, the formulation used in the tower did not contain glutaraldehyde. A certified industrial hygienist (CIH) who assessed exposure to Dri-Eaz Milgo

SR® several days after the spraying concluded that spraying the diluted solution did not create a health hazard. The CIH also stated that the source of water needed for mold growth appeared to be moisture that condensed on concrete and metal surfaces in non-air conditioned areas during humid summer months.

A March 7, 2005, PowerPoint presentation (“DTW Mold Remediation Plan”) describes plans to address mold in the short- and long-term. Short-term plans included identifying and correcting moisture problems, performing monthly inspections to identify new mold growth, and performing air sampling as necessary. Long-term plans included verifying the source of moisture (thought to be due to temperature variance), performing a mechanical engineering evaluation of the heating, ventilating, and air-conditioning (HVAC) system, and a structural engineering evaluation of elevator shaft construction. Long-term plans also called for continued remediation, i.e., replacing contaminated drywall, and painting/sealing drywall surfaces.

FAA Weekly Progress Reports for May 2005, indicate that remediation was continued as described in the March 7 presentation. Remediation was conducted under the supervision of an FAA CIH and a consultant CIH. According to the progress reports, the drywall replacement project was 98% complete as of May 17, 2005.

On June 21-22, 2005, a multidisciplinary team from Jacobs Engineering Group, comprised of an architect, mechanical engineer, and CIH conducted a qualitative moisture assessment and a limited visual inspection for mold. The architectural survey identified conditions that could allow water to penetrate the building envelope and migrate to interior locations where it would wick into drywall partitions. Conditions identified in the report include deteriorated caulking in joints between pre-cast concrete panels, absence of a waterproof traffic membrane on microwave antenna balconies, and drywall partitions (newly installed and existing) in contact with concrete floor slabs. The mechanical engineering survey determined that the ATCT was under negative pressure, and the HVAC system was operating in the economizer mode, bringing moist outdoor air into the ATCT. The survey also determined that the vestibule ventilation system was inoperable, the building automation system was unreliable, and facilities personnel needed adequate training regarding operation of the system.

When considered collectively, the various reports and documents provided to NIOSH describe a situation whereby leaks in the building envelope had allowed water to enter the ATCT, wick into drywall, and create a suitable substrate for mold growth. Mold contamination on drywall resulted in employees’ health concerns. This situation has existed since sometime in 2004 (possibly earlier), and can be expected to continue or recur until all leaks have been repaired, HVAC deficiencies corrected, and all mold sources located and successfully remediated. Until this remediation takes place, the employees who experience upper airway symptoms when exposed to mold may continue to experience them.

Environmental Sampling for Mold

Although surface sampling confirmed the presence of mold in certain interior locations of the ATCT, we did not find bioaerosol sampling results to be helpful in assessing the extent to which mold may have contributed to health problems among employees. In most cases, bioaerosol sampling is not useful as an environmental evaluation method, as few criteria are available to assist in the interpretation of the data. Without exposure guidelines for mold in air, it is not possible to distinguish between "safe" and "unsafe" levels of exposure. Furthermore, dose-response relationship information is lacking, and the mere presence of bioaerosols in samples does not prove a causal relationship with complaints. Bioaerosol sampling may be useful to compare complaint areas to noncomplaint areas, and to compare indoor air with outdoor air; however, this effort is often an unnecessary expense that does nothing to remove bioaerosol source reservoirs. A more cost-effective approach is to visually locate bioaerosol sources (microbial contamination), and eliminate the sources following remediation guidelines developed by organizations such as the U.S. Environmental Protection Agency, New York City Department of Health, and the American Conference of Governmental Industrial Hygienists (ACGIH®). These guidelines should be followed to ensure that environmental assessments are designed and conducted in a manner that provides adequate, accurate information, and that remediation not only eliminates the mold, but corrects the underlying cause(s) responsible for water intrusion. In addition, adherence to established guidelines will ensure that the safety and health of building occupants and remediators is not compromised.

When locating mold sources, it is important to inspect for mold that may be growing on hidden surfaces inside interior walls, beneath carpet or wallpaper, in pipe chases, etc. All drywall in the ATCT, which may have become wet, should be inspected for mold growth. This includes drywall in concealed areas, interior surfaces of walls, "inaccessible" locations, and all other areas where leaks may have caused building materials to become a suitable substrate for mold growth.

Medical Review

We reviewed the written symptoms profile and medical records provided by requesters on some of the employees who worked at the control tower. Dr. Ayodele Adebayo, spoke with Dr. Nestor Kowalsky, FAA Regional Flight Surgeon. Dr. Kowalsky was aware of the employees' concerns; however, he was not involved in their care. We repeatedly attempted to contact one of the treating physicians, Dr. Michael Harbut, Chief of the Center for Occupational/Environmental Medicine in Royal Oak, Michigan. Dr. Harbut did not return our telephone calls.

A review of the submitted symptoms profile revealed that prior to January 22, 2005, some employees had low-level non-specific symptoms such as fatigue and headaches. On January 22, 2005, there was an outbreak of upper respiratory tract irritation symptoms such as dry/itchy throat, burning eyes, runny nose, sneezing, and nasal congestion. Other reported symptoms were cough, shortness of breath, chest tightness, skin rash, nausea, and vomiting. Some employees' symptoms were severe enough to warrant emergency room visits. Since then, there have been reports of current and ongoing symptoms that start a few hours into the work shift and diminish when away from work.

Additionally, reports of new-onset asthma and *Chlamydiae pneumoniae* pneumonia were deemed related to employment in the ATCT. The NIOSH physician could not substantiate such diagnoses based on the medical records provided. Our request to receive updated medical records from employees was not fulfilled.

The Institute of Medicine (IOM) of the National Academies has found that some upper respiratory tract symptoms, such as those reported by FAA employees (dry/itchy throat, runny nose, sneezing, and nasal congestion) are associated with damp indoor environments and the presence of mold or other agents in damp indoor environments.¹ The presence of these symptoms among employees in the ACTC may indicate exposure to mold or damp indoor air. While some employees reported being diagnosed with new-onset asthma, we could not substantiate that diagnosis based on the medical records provided. The IOM has found only limited or suggestive evidence of an association between damp indoor environments, or the presence of mold or other agents in damp indoor environments, and the development of asthma in individuals without previous asthma.¹

The medical records provided to us did not substantiate the diagnosis of *C. pneumoniae* pneumonia among some FAA employees. The criterion for making a diagnosis of acute *C. pneumoniae* infection when using microimmunofluorescence assay is through a four-fold rise in IgG, or an IgM titer of $\geq 1:16$.² Although a single IgG of $\geq 1:512$ may suggest an acute infection, the use of a single assay in making a diagnosis of acute *C. pneumoniae* infection is strongly discouraged.² It should be noted that *C. pneumoniae* is a bacterium, not a fungus (mold).

Regarding the other reported symptoms, the IOM concluded that the evidence of an association between damp indoor environments or exposure to moldy environments, and skin symptoms, mucous membrane irritation syndrome, lower respiratory illness in otherwise healthy adults, fatigue, neuropsychiatric symptoms, and immune diseases is either inadequate or insufficient.¹ It should be noted that the absence of sufficient evidence of an association is not synonymous with lack of an association, and that the IOM conclusions only apply to immunocompetent persons. Therefore, the conclusion that mold is not a threat to the health of ATCT employees, as stated in an FAA letter dated December 16, 2006, is not substantiated by scientific evidence. It is imperative to provide employees a work environment free from mold and environmental factors that cause mold growth. In order to achieve this goal, we recommend the following:

1. Inspect all locations where building materials may have become wet. Mold that is not actively growing can still present a health hazard, and may resume growing when conditions become favorable.
2. Perform corrective actions recommended in the Jacobs Engineering Group report to help ensure that all sources of moisture are eliminated and the HVAC system operates properly.

Page 6 – Federal Aviation Administration

This letter closes our file on this health hazard evaluation request. NIOSH recommends that employers post a copy of this letter for 30 days at or near work areas of affected employees.

If you have questions or concerns about this report, please do not hesitate to contact us. David Sylvain can be contacted at (508) 997-6126 or by e-mail at dsylvain@cdc.gov; Dr. Adebayo at (513) 841-4116 or aadebayo@cdc.gov.

Sincerely yours,

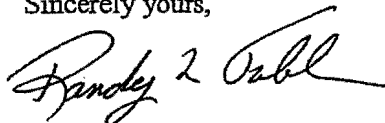

for David C. Sylvain, M.S., CIH
Regional Industrial Hygienist

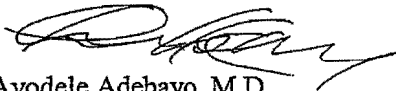

Ayodele Adebayo, M.D.
Medical Officer

Hazard Evaluations and Technical
Assistance Branch
Division of Surveillance, Hazard
Evaluations and Field Studies

cc: confidential requestors
Wayne Vogelsburg
Annie Glenn

References

1. Committee on Damp Indoor Spaces and Health Board on Health Promotion and Disease Prevention, Institute of Medicine of the National Academies, *Damp Indoor Spaces and Health*. 2004, Washington, D.C.: National Academies Press.
2. Dowell SF, Peeling RW, Boman J, Carlone GM, Fields BS, Guarner J, Hammerschlag MR, Jackson LA, Kuo CC, Maass M, Messmer TO, Talkington DF, Tondella ML, Zaki SR; C. pneumoniae workshop participants [2001]. Standardizing Chlamydia pneumoniae assays: recommendations from the Centers for Disease Control and Prevention (USA) and the Laboratory Centre for Disease Control (Canada). *Clin Infect Dis*. 33(4):492-503.

Appendix

Background

Employees working in buildings may experience a wide range of health symptoms. Many symptoms are thought to be associated with the building because they improve or disappear completely when the employees are away from the workplace. These building-associated health symptoms may include mucous membrane discomfort (eye/nose/throat irritation), headache, and fatigue. Potential causes of these symptoms have been extensively researched, but in most cases no identifiable cause in the workplace can be found. Distinct from these are illnesses that have a specific medical diagnosis, and can be determined by a physician through a medical evaluation and an assessment of work-relatedness. These illnesses can often be associated with specific indoor exposures such as molds, carbon monoxide, and certain bacteria (e.g., *Legionella*).

Concern about indoor environmental quality (IEQ) problems related to molds in the workplace has been increasing with heightened public awareness, primarily through the popular media. Although this may appear to be a recent problem, exposure to molds has occurred throughout history. In fact, the types of molds found in buildings are not rare or even unique to the building environment.

Molds are a type of fungi and, unlike plants, lack chlorophyll. They survive by using plants and decaying organic matter for food. Molds reproduce by releasing tiny spores that are carried by air currents to other locations. Mold spores are so small that the human eye needs magnification to see them. Molds are widely distributed in nature, and human exposure to mold spores occurs commonly, both indoors and outdoors, at home and at work. No environment is completely free from mold spores, not even a surgical operating room.

Medical Issues

A small percentage of people may experience symptoms such as mucous membrane irritation, runny nose, and upper airway congestion when exposed to excessive mold growth in a building. Less common symptoms such as breathing difficulties may also occur. The types and severity of symptoms depend in part on the types and extent of the mold present, the extent of the individual's exposure, and the susceptibility of the individual (for example, whether she or he has pre-existing allergies or asthma). In general, excessive exposure to mold may produce health problems by several primary mechanisms, including (1) allergy or hypersensitivity, (2) irritant effects, (3) infection, and (4) toxic effects. Each of these is discussed below.

Allergy or Hypersensitivity

Inhaling or touching mold or mold spores may cause allergic reactions in sensitized (allergic) individuals. Allergic responses are usually characterized by sneezing; itching of the nose, eyes, mouth, or throat; nasal stuffiness and runny nose; and red, itchy eyes. Repeated or single

exposure to mold or mold spores may cause previously non-sensitized individuals to become sensitized.

Molds can trigger asthma symptoms (shortness of breath, wheezing, cough) in persons who are allergic to mold. A recent review of the scientific literature concluded that exposure to molds in the indoor environment may make pre-existing asthma worse, but also concluded that there was not enough evidence to determine whether exposure to mold in the indoor environment could cause asthma.

Hypersensitivity pneumonitis, which can result when the immune system reacts to certain types of inhaled substances (such as mold spores), is a rare illness which may resemble bacterial pneumonia. Typically this condition involves respiratory symptoms (such as cough, wheezing, or shortness of breath) as well as other symptoms (such as extreme fatigue and low-grade fever). It has developed in people following both short-term (acute) and long-term (chronic) exposure to molds.

Irritant Effects

Exposure to excessive concentrations of molds in airborne dust can cause irritation of the eyes, skin, nose, throat, and lungs. Irritation of the upper and lower airways may worsen pre-existing conditions such as allergic symptoms or asthma. Molds produce a variety of volatile organic compounds, the most common of which is ethanol, that may also cause upper airway irritation.

Infection

People with weakened immune systems (immune-compromised or immune-suppressed individuals) may be more vulnerable to infections by molds. For example, *Aspergillus fumigatus*, a mold that has been found almost everywhere on every conceivable type of substrate, has been known to infect the lungs of immune-compromised individuals after they inhale airborne spores. Healthy individuals are usually not vulnerable to infections from airborne mold exposure.

Toxic Effects

Recently, concern has increase about exposure to specific molds that produce toxic substances called mycotoxins. Illness associated with exposures (from inhalation and/or skin contact) to mycotoxins in agricultural or industrial environments has been reported. However, no conclusive evidence currently links mycotoxin exposure in the indoor environment and human illness. Some of the molds that are known to produce mycotoxins have been commonly found in moisture-damaged buildings; research is ongoing related to the importance of these findings.

Medical Treatment

Minimizing exposure to mold will likely require effective communication between employees (or employee representatives) and those persons responsible for maintaining the building environment, as well as effective actions by the building maintenance staff should a problem be found. Individuals concerned about their symptoms are encouraged to seek medical attention to ensure the proper diagnosis and treatment. A systematic clinical approach for evaluating persons with suspected building-related symptoms or illness is recommended. Recognizing and treating workers with serious building-related illness, if present, is important to prevent chronic disease.

Environmental Issues

There are no exposure guidelines for mold in air. Therefore, it is not possible to distinguish between “safe” and “unsafe” levels of exposure. We do know, however, that moisture intrusion along with nutrient sources such as building materials or furnishings allows mold to grow indoors. It is extremely important, therefore, to keep the building interior and furnishings dry to prevent unwanted mold growth.

Indoor Mold Prevention

The key to preventing indoor mold contamination is to control interior moisture. Each of the following should be considered.

- Repair leaks in the building envelope and plumbing/sewage systems.
- Prevent condensation through insulation, increasing surface temperature, or increasing air circulation.
- Vent any moisture-producing equipment or appliances to the outdoors.
- Maintain interior relative humidity below 60% (ideally between 30% and 50%) to minimize mold growth. Dehumidify as necessary to achieve this level.
- Ensure that air conditioning systems are adequately drained to prevent standing water.
- Clean up and dry any wet or damp spots within 48 hours.
- Ensure that water drains away from the building foundation.
- Routinely inspect and maintain the building and building systems.

Indoor Mold Remediation

Preventing indoor mold growth and remediating indoor mold contamination may prevent health problems. Remediation should follow the guidelines described in the Environmental Protection

Agency's document, "Mold Remediation in Schools and Commercial Buildings." This document describes the steps necessary to clean up mold contamination while protecting the cleanup workers, the building occupants, and the surrounding indoor environment. Additional information regarding IEQ issues in general and the evaluation and remediation of indoor mold contamination specifically, is available from the Environmental Protection Agency at <http://www.epa.gov/iaq>.

Selected References

ACGIH [1999]. *Bioaerosols: assessment and control*. Cincinnati, OH: American Conference of Governmental Industrial Hygienists.

AIHA [1996]. *Field guide for the determination of biological contaminants in environmental samples*. Fairfax, VA: American Industrial Hygiene Association.

EPA [2001]. *Mold remediation in schools and commercial buildings*. Washington, DC: Environmental Protection Agency.

IICRC [1999]. *IICRC S500 — standard and reference guide for professional water damage restoration*. Vancouver, WA: Institute of Inspection, Cleaning, and Restoration Certification.

Institute of Medicine [2000]. *Executive Summary*. In: *Clearing the air; asthma and indoor air exposure*. Washington DC: National Academy Press, pp. 1–18.

Kreiss K [1990]. The sick building syndrome: where is the epidemiologic basis? *Am J Public Health* 80:1172–1173.

CDC. Update: pulmonary hemorrhage/hemosiderosis among infants — 1993–1996. *MMWR* 2000; 49(09):180–184.

Menzies D, Bourbeau J [1997]. Building-related illnesses. *N Eng J Med* 337(21):1524–1531.

Page E, Trout D [1998]. Mycotoxins and building-related illness (letter to the Editor). *J Occup Environ Med* 40(9):761–63.

Robbins C, Swenson L, Neally M, Gots R, Kelman B [2000]. Health effects of mycotoxins in indoor air: a critical review. *Appl Occ Environ Hyg* 15(10):773–784.

5



DEPARTMENT OF HEALTH AND HUMAN SERVICES

Public Health Service
National Institute for Occupational
Safety and Health
Robert A. Taft Laboratories
4676 Columbia Parkway
Cincinnati OH 45226-1998
January 11, 2007
HETA 2006-0004

Federal Aviation Administration
Attn: Jo L. Tarrh
Director, Central Service Area for Technical Operations
Southwest Region Headquarters
2601 Meacham Blvd.
Fort Worth, Texas 76137-4298

Dear Ms. Tarrh:

I have reviewed additional medical information provided by Dr. Harbut for six air traffic control tower employees (ATCT) at Detroit Metro Airport in Wayne County, Michigan. Dr. Harbut provided these records to complement the materials and information that we collected as part of the health hazard evaluation (HHE) at the Detroit Metro Airport ATCT (HETA 2006-0004).

Although the six records identified employees with respiratory health effects that may be associated with mold exposure, the added information does not change the conclusions or the recommendations we noted in the letter sent to you on July 24, 2006. We believe that the implementation of our initial recommendations should be sufficient to eliminate the factors that make the environment conducive for mold growth and also prevent further employee exposure. Because of the lack of specificity of the medical findings, the statistical problems associated with studying a small population, and the lack of any added benefit from carrying out an extensive mold study at the control tower, we have decided not to re-open this evaluation. We encourage management to implement our recommendations and affected employees to continue to seek care from their healthcare providers in the management of their health problems and concerns.

In my telephone discussion with Dr. Harbut, he expressed a concern for employees with memory problems. We were able to identify two employees with complaints of memory problems from the medical documents made available to us. We strongly recommend that individuals with memory loss seek care with their providers as earlier suggested to them by Dr. Harbut.

Thank you for your cooperation with this evaluation. If you have any questions, please do not hesitate to contact me at (513) 841-4116.

Sincerely yours,

Ayodele Adebayo, M.D., M.P.H.
Medical Officer
Hazard Evaluations and Technical
Assistance Branch
Division of Surveillance, Hazard
Evaluations and Field Studies

cc:
Confidential Requestors
Wayne Vogelsburg
Annie Glerm
Michael Harbut

6



DEPARTMENT OF HEALTH AND HUMAN SERVICES
 Centers for Disease Control and Prevention
 National Institute for Occupational Safety and Health

U.S. Public Health Service

New England Field Office
 P.O. Box 87040
 South Dartmouth, MA 02748-0701

August 16, 2006
 HETA 2006-0004

RECEIVED AUG 22 2006
 10 AM

Federal Aviation Administration
 Attn: Jo L. Tarrh
 Director, Central Service Area for Technical Operations
 Southwest Region Headquarters
 2601 Meacham Blvd.
 Fort Worth, Texas 76137-4298

Dear Ms. Tarr:

I am writing to correct an inaccurate statement that appears in the letter that was mailed to you on July 24, 2006. On page 4, the letter states that Dr. Michael Harbut failed to contact NIOSH investigators. As it turns out, Dr. Harbut had attempted to contact NIOSH, but had been given the wrong telephone number, so he could not return the call. Dr. Harbut was subsequently able to reach NIOSH investigators, and has offered to provide medical records for review by NIOSH. NIOSH investigators will review these records to determine whether additional evaluation by NIOSH is warranted.

If you have any questions regarding the report or the medical record review, please feel free to contact me at (508) 997-6126, or Dr. Adebayo at (513) 841-4116.

Sincerely yours,

David Sylvain, CIH
 Regional Industrial Hygienist

cc: confidential requestors
 Annie Glenn
 Michael Harbut, M.D.
 Wayne Vogelsburg

Director
 MS
 ES
 TS
 SS

AUG 18 '06 PM 3:12

7

PERFORMANCE OF WORK ITEMS

MICROBIOLOGICAL REMEDIATION PROJECT AT DETROIT METROPOLITAN AIRPORT AIR TRAFFIC CONTROL TOWER

The contractor shall provide all the services, equipment, supplies, materials, and labor required. Work shall include, but not limited to, the following:

ALL FLOORS:

1. Prior to performing microbiological remediation procedures, the contractor shall seal all critical penetrations and openings to the work area with a minimum of two layers of 6-mil polyethylene, and shall be responsible for ensuring adjoining areas are not exposed to the microbiological contamination during the remediation.
2. Remove any MCM between the bottom metal runner/track and the concrete floor; between the top metal runner/track and the structural deck; and between the metal stud and exterior concrete wall.
3. The contractor shall minimize dust generation and use the methodologies outlined in *Guidelines on Assessment and Remediation of Fungi in Indoor Environments* (GARFIE) (See Specification Attachment 1) for dust prevention and suppression.
4. All removals and other cleaning procedures shall be conducted at night between the hours of 11:00 pm and 6:00 am. Negative air pressure equipment shall be equipped with a HEPA filter and discharged outside of the building whenever possible, otherwise discharged through a second HEPA filter in order to permit recirculation of air inside the building.

FLOOR 3

ROOM 327

1. The contractor shall provide additional cleaning procedures and pipe insulation removal/replacement.
2. Approximately 15 linear feet of 18", water stained and/or contaminated chilled and heating water pipe insulation shall be removed and replaced.

ROOM 328

1. A mini containment shall be established consisting of a single layer of 6-mil polyethylene sheeting. A negative pressure enclosure system shall be established as described in section 1B.10 Remediation area.
2. The east (elevator shaft) wall, up to a height of 2', and the south (elevator shaft) wall, up to a height of 2', shall be HEPA vacuumed and then wet wiped with an approved cleaning solution.

FLOOR 4

ROOM 427

1. The contractor shall provide additional cleaning procedures and pipe insulation removal/replacement.
2. Approximately 4 linear feet of 11" and 6 linear feet of 18" water stained and/or contaminated chilled and heating water pipe insulation shall be removed and replaced.

ROOM 428

1. A containment and negative pressure enclosure system shall be established as described in section 1B.10 Remediation area. A decontamination unit shall be established as described in section 1B.11 Decontamination.
2. Cleanup and removal of moisture and microbiological contaminated gypsum board, shaft liner, and insulation in the DTW ATCT room 428 in accordance with the guidelines established by the New York City Department of Health entitled *Guidelines on Assessment and Remediation of Fungi in Indoor Environments* (GARFIE) (See Specification Attachment 1).
3. Remove gypsum board, shaft liner, and insulation totaling approximately 243 square feet:
 - a. The east (elevator shaft) wall, 8' wide to a height of 5' (surface layer), 8' wide to a height of 4'6" (concealed layer), and 8' wide to a height of 4' (shaft liner).
 - b. The south (elevator shaft) wall, 10' wide to a height of 5' (surface layer), 10' wide to a height of 4'6" (concealed layer), and 10' wide to a height of 4' (shaft liner).
 - c. **Elevator Shaft liner removal and replacement requires coordination with the Elevator Maintenance company and Air Traffic to schedule limited elevator shutdown time.**

FLOOR 5

ROOM 527

1. A containment and negative pressure enclosure system shall be established as described in section 1B.10 remediation area. A decontamination unit shall be established as described in section 1B.11 Decontamination.
2. Cleanup and removal of moisture and microbiological contaminated gypsum board, shaft liner, and insulation in accordance with the guidelines established by the New York City Department of Health entitled *Guidelines On Assessment And Remediation Of Fungi In Indoor Environments* (GARFIE) (See Specification Attachment 1).

3. Approximately 4 linear feet of 11" and 25 linear feet of 18" water stained and/or contaminated chilled and heating water pipe insulation shall be removed and replaced.
4. Remove gypsum board and insulation totaling approximately 15 square feet, 2' wide to a height of 4' (surface layer) and 2' wide to a height of 3'6" (concealed layer).

ROOM 527A

1. A containment and negative pressure enclosure system shall be established as described in section 1B.10 Remediation area. A decontamination unit shall be established as described in section 1B.11 Decontamination.
2. Cleanup and removal of moisture and microbiological contaminated gypsum board, shaft liner, and insulation in accordance with the guidelines established by the New York City Department of Health Entitled *Guidelines on Assessment and Remediation of Fungi in Indoor Environments* (GARFIE) (See Specification Attachment 1).
3. Remove gypsum board and insulation totaling approximately 15 square feet from the portion of the north wall, between the east wall and the door to room 527A, 2' wide to a height of 4' (surface layer) and 2' wide to a height of 3'6" (concealed layer).

ROOM 529

1. A mini containment shall be established consisting of a single layer of 6-mil polyethylene sheeting but a negative pressure enclosure system is not required. Mist any contaminated areas prior to removal. Upon completion, the work area shall be HEPA vacuumed and then wet wiped with a detergent solution.
2. The portion of the east wall, between the south wall and stairwell doorframe, 2' wide to a height of 8', shall be HEPA vacuumed and then wet wiped with an approved cleaning solution.

FLOOR 6

ROOM 627

1. The contractor shall provide additional cleaning procedures and pipe insulation removal/replacement.
2. Approximately 20 linear feet of 11" and 25 linear feet of 18" water stained and/or contaminated chilled and heating water pipe insulation shall be removed and replaced.

ROOM 628

1. A mini containment shall be established consisting of a single layer of 6-mil polyethylene sheeting. A negative pressure enclosure system shall be established as described in section 1B.10 Remediation area.
2. The east (elevator shaft) wall, up to a height of 4', shall be HEPA vacuumed and then wet wiped with an approved cleaning solution.
3. The south (elevator shaft) wall, up to a height of 4', shall be HEPA vacuumed and then wet wiped with an approved cleaning solution.

FLOOR 7

ROOM 727

1. The contractor shall provide additional cleaning procedures and pipe insulation removal/replacement.
2. Approximately 3 linear feet of 18" water stained and/or contaminated chilled and heating water pipe insulation shall be removed and replaced.

ROOM 727A

1. A mini containment shall be established consisting of a single layer of 6-mil polyethylene sheeting. A negative pressure enclosure system shall be established as described in section 1B.10 Remediation area.
2. The portion of the west wall between the cable tray and the north wall, up to a height of 4', shall be HEPA vacuumed and then wet wiped with an approved cleaning solution.
3. The south wall above the door to room 727, 3' wide to a height of 3', shall be HEPA vacuumed and then wet wiped with an approved cleaning solution.

ROOM 728

1. A mini containment shall be established consisting of a single layer of 6-mil polyethylene sheeting. A negative pressure enclosure system shall be established as described in section 1B.10 Remediation area.
2. The east (elevator shaft) wall, up to a height of 4', shall be HEPA vacuumed and then wet wiped with an approved cleaning solution.
3. The south (elevator shaft) wall, up to a height of 4', shall be HEPA vacuumed and then wet wiped with an approved cleaning solution.

FLOOR 8

ROOM 827

1. The contractor shall provide additional cleaning procedures and pipe insulation removal/replacement.

2. Approximately 4 linear feet of 11" water stained and/or contaminated chilled and heating water pipe insulation shall be removed and replaced.

ROOM 829

1. A mini containment shall be established consisting of a single layer of 6-mil polyethylene sheeting. A negative pressure enclosure system shall be established as described in section 1B.10 Remediation area.
2. The portion of the east wall, between the south wall and stairwell doorframe, 2" wide to a height of 8', shall be HEPA vacuumed and then wet wiped with an approved cleaning solution.
3. The adjacent south wall, from the southeast corner westward, 1' wide to a height of 8', shall be HEPA vacuumed and then wet wiped with an approved cleaning solution.

FLOOR 9

ROOM 927

1. The contractor shall provide additional cleaning procedures and pipe insulation removal/replacement.
2. Approximately 4 linear feet of 11" water stained and/or contaminated chilled and heating water pipe insulation shall be removed and replaced.

ROOM 928

1. A containment and negative pressure enclosure system shall be established as described in section 1B.10 Remediation area. A decontamination unit shall be established as described in section 1B.11 Decontamination.
2. Cleanup and removal of moisture and microbiological contaminated gypsum board, shaft liner, and insulation in the DTW ATCT rooms 928, in accordance with the guidelines established by the New York City Department of Health Entitled *Guidelines on Assessment and Remediation of Fungi in Indoor Environments* (GARFIE) attached and incorporated herein by reference (see attachment 1).
3. Gypsum board, shaft liner, and insulation totaling approximately 311 square feet will be removed this area:
 - a. The east (elevator shaft) wall, 8' wide to a height of 5' (surface layer), 8' wide to a height of 4'6" (concealed layer), and 8' wide to a height of 4' (shaft liner).
 - b. The south (elevator shaft) wall, 10' wide to a height of 5' (surface layer), 10' wide to a height of 4'6" (concealed layer), and 10' wide to a height of 4' (shaft liner).

- c. The northwest column beam enclosure, on the north wall, 6' wide to a height of 3' (surface layer), 6' wide to a height of 2'6" (concealed layer), and 6' wide to a height of 2' (shaft liner);
- d. The west wall, 3' wide to a height of 3' (surface layer), 3' wide to a height of 2'6" (concealed layer), and 3' wide to a height of 2' (shaft liner).
- e. **Elevator Shaft liner removal and replacement requires coordination with the Elevator Maintenance company and Air Traffic to schedule limited elevator shutdown time.**

FLOOR 10

ROOM 1028

1. A mini containment shall be established consisting of a single layer of 6-mil polyethylene sheeting. A negative pressure enclosure system shall be established as described in section 1B.10 Remediation area.
2. The north wall shaft liner in its entirety shall be HEPA vacuumed and then wet wiped with an approved cleaning solution.

Specification
Microbiological Remediation
at
Detroit Metropolitan Airport
Air Traffic Control Tower

FAA-DTW-ATCT-xxxx

July 11, 2008

U.S. DEPARTMENT OF TRANSPORTATION
FEDERAL AVIATION ADMINISTRATION
Infrastructure Support Detached Staff
Willow Run Airport, East
8808 Beck Road
Belleville, Michigan 48111

Diane I. Morse
(734) 487-7330

TABLE OF CONTENTS

DIVISION 1 - GENERAL REQUIREMENTS3
SECTION 1A - GENERAL REQUIREMENTS3
SECTION 1B - SPECIAL REQUIREMENTS7
SECTION 1C - SUBMITTALS11
SECTION 1D - ABATEMENT13
DIVISION 9 - FINISHES15
SECTION 9A - GYPSUM BOARD15

DIVISION 1 - GENERAL REQUIREMENTS
SECTION 1A - GENERAL REQUIREMENTS

1A.1 Summary of Work. The work described consists of furnishing all necessary materials, labor, equipment, tools and supervision to remove and replace portions of the airport traffic control tower drywall. The project is located in Romulus, Michigan.

1A.2 Scope of Work. The Contractor is required to furnish all labor, materials, services, equipment, insurance, and perform all the work to remove and dispose of all microbiological contaminated materials (MCM) and microbiological contaminated elements (MCE) described in this Scope of Work (SOW). The Contractor shall be responsible for:

These specifications, together with other referenced documents, standards, and drawings in the contract documents, cover the requirements for all work associated with the drywall replacement.

ALL FLOORS:

1. Prior to performing microbiological remediation procedures, the contractor shall seal all critical penetrations and openings to the work area with a minimum of two layers of 6-mil polyethylene, and shall be responsible for ensuring adjoining areas are not exposed to the microbiological contamination during the remediation.
2. Remove any MCM between the bottom metal runner/track and the concrete floor; between the top metal runner/track and the structural deck; and between the metal stud and exterior concrete wall.
3. The contractor shall minimize dust generation and use the methodologies outlined in *Guidelines on Assessment and Remediation of Fungi in Indoor Environments (GARFIE)* (See Specification Attachment 1) for dust prevention and suppression.
4. All removals and other cleaning procedures shall be conducted at night between the hours of 11:00 pm and 6:00 am. Negative air pressure equipment shall be equipped with a HEPA filter and discharged outside of the building whenever possible, otherwise discharged through a second HEPA filter in order to permit recirculation of air inside the building.

FLOOR 3

ROOM 327

1. The contractor shall provide additional cleaning procedures and pipe insulation removal/replacement.
2. Approximately 15 linear feet of 18", water stained and/or contaminated chilled and heating water pipe insulation shall be removed and replaced.

ROOM 328

1. A mini containment shall be established consisting of a single layer of 6-mil polyethylene sheeting. A negative pressure enclosure system shall be established as described in section 1B.10 Remediation area.
2. The east (elevator shaft) wall, up to a height of 2', and the south (elevator shaft) wall, up to a height of 2', shall be HEPA vacuumed and then wet wiped with an approved cleaning solution.

FLOOR 4

ROOM 427

1. The contractor shall provide additional cleaning procedures and pipe insulation removal/replacement.

2. Approximately 4 linear feet of 11" and 6 linear feet of 18" water stained and/or contaminated chilled and heating water pipe insulation shall be removed and replaced.

ROOM 428

1. A containment and negative pressure enclosure system shall be established as described in section 1B.10 Remediation area. A decontamination unit shall be established as described in section 1B.11 Decontamination.
2. Cleanup and removal of moisture and microbiological contaminated gypsum board, shaft liner, and insulation in the DTW ATCT room 428 in accordance with the guidelines established by the New York City Department of Health entitled *Guidelines on Assessment and Remediation of Fungi in Indoor Environments* (GARFIE) (See Specification Attachment 1).
3. Remove gypsum board, shaft liner, and insulation totaling approximately 243 square feet:
 - a. The east (elevator shaft) wall, 8' wide to a height of 5' (surface layer), 8' wide to a height of 4'6" concealed layer), and 8' wide to a height of 4' (shaft liner).
 - b. The south (elevator shaft) wall, 10' wide to a height of 5' (surface layer), 10' wide to a height of 4'6" (concealed layer), and 10' wide to a height of 4' (shaft liner).
 - c. **Elevator Shaft liner removal and replacement requires coordination with the Elevator Maintenance company and Air Traffic to schedule limited elevator shutdown time.**

FLOOR 5 ROOM 527

1. A containment and negative pressure enclosure system shall be established as described in section 1B.10 Remediation area. A decontamination unit shall be established as described in section 1B.11 Decontamination.
2. Cleanup and removal of moisture and microbiological contaminated gypsum board, shaft liner, and insulation in accordance with the guidelines established by the New York City Department of Health entitled *Guidelines on Assessment and Remediation of Fungi in Indoor Environments* (GARFIE) (See Specification Attachment 1).
3. Approximately 4 linear feet of 11" and 25 linear feet of 18" water stained and/or contaminated chilled and heating water pipe insulation shall be removed and replaced.
4. Remove gypsum board and insulation totaling approximately 15 square feet, 2' wide to a height of 4' (surface layer) and 2' wide to a height of 3'6" (concealed layer).

ROOM 527A

1. A containment and negative pressure enclosure system shall be established as described in section 1B.10 Remediation area. A decontamination unit shall be established as described in section 1B.11 Decontamination.
2. Cleanup and removal of moisture and microbiological contaminated gypsum board, shaft liner, and insulation in accordance with the guidelines established by the New York City Department of Health Entitled *Guidelines on Assessment and Remediation of Fungi in Indoor Environments* (GARFIE) (See Specification Attachment 1).
3. Remove gypsum board and insulation totaling approximately 15 square feet from the portion of the north wall, between the east wall and the door to room 527A, 2' wide to a height of 4' (surface layer) and 2' wide to a height of 3'6" (concealed layer).

ROOM 529

1. A mini containment shall be established consisting of a single layer of 6-mil polyethylene sheeting but a negative pressure enclosure system is not required. Mist any contaminated areas prior to removal. Upon completion, the work area shall be HEPA vacuumed and then wet wiped with a detergent solution.
2. The portion of the east wall, between the south wall and stairwell doorframe, 2" wide to a height of 8', shall be HEPA vacuumed and then wet wiped with an approved cleaning solution.

FLOOR 6
ROOM 627

1. The contractor shall provide additional cleaning procedures and pipe insulation removal/replacement.
2. Approximately 20 linear feet of 11" and 25 linear feet of 18" water stained and/or contaminated chilled and heating water pipe insulation shall be removed and replaced.

ROOM 628

1. A mini containment shall be established consisting of a single layer of 6-mil polyethylene sheeting. A negative pressure enclosure system shall be established as described in section 1B.10 Remediation area.
2. The east (elevator shaft) wall, up to a height of 4', shall be HEPA vacuumed and then wet wiped with an approved cleaning solution.
3. The south (elevator shaft) wall, up to a height of 4', shall be HEPA vacuumed and then wet wiped with an approved cleaning solution.

FLOOR 7
ROOM 727

1. The contractor shall provide additional cleaning procedures and pipe insulation removal/replacement.
2. Approximately 3 linear feet of 18" water stained and/or contaminated chilled and heating water pipe insulation shall be removed and replaced.

ROOM 727A

1. A mini containment shall be established consisting of a single layer of 6-mil polyethylene sheeting. A negative pressure enclosure system shall be established as described in section 1B.10 Remediation area.
2. The portion of the west wall between the cable tray and the north wall, up to a height of 4', shall be HEPA vacuumed and then wet wiped with an approved cleaning solution.
3. The south wall above the door to room 727, 3' wide to a height of 3', shall be HEPA vacuumed and then wet wiped with an approved cleaning solution.

ROOM 728

1. A mini containment shall be established consisting of a single layer of 6-mil polyethylene sheeting. A negative pressure enclosure system shall be established as described in section 1B.10 Remediation area.
2. The east (elevator shaft) wall, up to a height of 4', shall be HEPA vacuumed and then wet wiped with an approved cleaning solution.

3. The south (elevator shaft) wall, up to a height of 4', shall be HEPA vacuumed and then wet wiped with an approved cleaning solution.

FLOOR 8
ROOM 827

1. The contractor shall provide additional cleaning procedures and pipe insulation removal/replacement.
2. Approximately 4 linear feet of 11" water stained and/or contaminated chilled and heating water pipe insulation shall be removed and replaced.

ROOM 829

1. A mini containment shall be established consisting of a single layer of 6-mil polyethylene sheeting. A negative pressure enclosure system shall be established as described in section 1B.10 Remediation area.
2. The portion of the east wall, between the south wall and stairwell doorframe, 2" wide to a height of 8', shall be HEPA vacuumed and then wet wiped with an approved cleaning solution.
3. The adjacent south wall, from the southeast corner westward, 1' wide to a height of 8', shall be HEPA vacuumed and then wet wiped with an approved cleaning solution.

FLOOR 9
ROOM 927

1. The contractor shall provide additional cleaning procedures and pipe insulation removal/replacement.
2. Approximately 4 linear feet of 11" water stained and/or contaminated chilled and heating water pipe insulation shall be removed and replaced.

ROOM 928

1. A containment and negative pressure enclosure system shall be established as described in section 1B.10 Remediation area. A decontamination unit shall be established as described in section 1B.11 Decontamination.
2. Cleanup and removal of moisture and microbiological contaminated gypsum board, shaft liner, and insulation in the DTW ATCT rooms 928, in accordance with the guidelines established by the New York City Department of Health Entitled *Guidelines on Assessment and Remediation of Fungi in Indoor Environments (GARFIE)* attached and incorporated herein by reference (see attachment 1).
3. Gypsum board, shaft liner, and insulation totaling approximately 311 square feet will be removed this area:
 - a. The east (elevator shaft) wall, 8' wide to a height of 5' (surface layer), 8' wide to a height of 4'6" (concealed layer), and 8' wide to a height of 4' (shaft liner).
 - b. The south (elevator shaft) wall, 10' wide to a height of 5' (surface layer), 10' wide to a height of 4'6" (concealed layer), and 10' wide to a height of 4' (shaft liner).
 - c. The northwest column beam enclosure, on the north wall, 6' wide to a height of 3' (surface layer), 6' wide to a height of 2'6" (concealed layer), and 6' wide to a height of 2' (shaft liner);
 - d. The west wall, 3' wide to a height of 3' (surface layer), 3' wide to a height of 2'6" (concealed layer), and 3' wide to a height of 2' (shaft liner).
 - e. **Elevator Shaft liner removal and replacement requires coordination with the Elevator Maintenance company and Air Traffic to schedule limited elevator shutdown time.**

FLOOR 10
ROOM 1028

1. A mini containment shall be established consisting of a single layer of 6-mil polyethylene sheeting. A negative pressure enclosure system shall be established as described in section 1B.10 Remediation area.
2. The north wall shaft liner in its entirety shall be HEPA vacuumed and then wet wiped with an approved cleaning solution.

The removal method and all related work must be in conformance with FAA polices, U.S. Occupational Safety and Health Administration (OSHA) and all State of Michigan regulations.

SECTION 1B - SPECIAL REQUIREMENTS

- 1B.1 **COORDINATION.** All contacts between the contractor and Airway Facilities/Technical Operations shall be coordinated through the Resident Engineer and his/her designated representative.
- 1B.2. **CONTRACTOR'S RESPONSIBILITY.** The Contractor shall perform all work required to give a complete and satisfactory job as required by this Statement of Work. The Contractor shall be responsible for performing this work in accordance with GARFIE. The Contractor shall perform the work per the schedule and sequence identified in the SSOW. The Contractor shall be responsible for all debris generated under this contract at the job site and during transport of microbiological containing or contaminated materials to an approved disposal site.
- 1B.3 **SITE VISIT.** The Contractor is responsible for inspecting the work space and field verifying all quantities for: constructing a negative pressure enclosure for each phase of the work, MCM, MCE removal and disposal, work area physical parameters, access limitations, and Government phasing limitations. The Contractor shall be required to work around existing furniture, fixtures and finishes during the performance of this contract. The site visit shall be scheduled by the Government for interested microbiological remediation Contractors to identify specific work area and phasing requirements. The contractor shall take steps necessary to ascertain the nature of the work, and satisfy themselves to the conditions that can affect the work. No subsequent extras will be allowed due to any claim of lack of knowledge for conditions that can be determined by examining the site. Site visits can be arranged by contacting Facility Manager, Dave Saunders (734) 955-5101, at least 24 hours prior to the planned visit.
 - A. **Property Damage.** The Contractor shall take all precautions to avoid damage to Government property or equipment. Any damage to Government property or equipment by the Contractor shall be repaired by the Contractor to its original state or better condition at no additional expense to the Government.
 - B. **Working Conditions.** Portions of the ATCT will be occupied and Government operations will continue on a normal, temporary, or restricted basis for the duration of the project. The Contractor shall take all precautions to ensure that their operations are conducted in a manner that does not interfere with the normal operations of the surrounding facilities and the safety and health of the occupants or the environment. Contractor's personnel will have limited access to the facility.
 - C. **Cleanup.** Upon completion of the work at the site, all staging and debris from the project shall be removed from the site and disposed of properly. The entire area shall be left clean and acceptable to the Government.
 - D. **Certifications.** The Contractor shall be certified by the Indoor Air Quality Association (IAQA), the Institute of Inspection, Cleaning, and Restoration (IICR), the National Duct Cleaning Association (NADCA) or equivalent.
- 1B.4. **SCHEDULE.** See contract documents for duration of contract and notice to proceed.

Working Hours. Due to noise-level and air-quality issues, the work shall be performed during off-peak hours.

The work shall be performed between 11:00 p.m. and 6:00 a.m. Eastern Time, Monday through Friday on Government workdays only, unless arranged at least 48 hours in advance with the FAA Resident Engineer (RE).

- 1B.5 **Pre-Construction Meeting.** The Contractor shall attend a mandatory pre-construction meeting before starting work and the Government will schedule the meeting. The contractor shall attend the conference and shall abide by all agreements reached at the conference regarding:
- A. Detailed procedures for administration of the project.
 - B. Identity of the Resident Engineer, authorized representative of the Government / Contracting Officer, and the contractor's superintendent(s).
 - C. Contractor's telephone number.
 - D. Detailed procedures for submittals.
 - E. Available storage areas for contractor's materials and equipment.
 - F. Compliance with FAA safety practices, general operating procedures and security regulations.
 - G. Availability of on site power for use by the contractor as determined by the Resident Engineer.
 - H. The FAA Pre-Construction and Maintenance Project Safety and Health Checklist, FAA form 3900-8 and the AGL Construction and Maintenance Project Ventilation and Airborne Contaminants Checklist will be reviewed and filled prior to the start of work.
 - I. Contractor shall provide copies of all MSDS sheet for any products and restoration materials to be used.
 - J. In addition to the foregoing, other subjects pertinent to the contract may be discussed.
- 1B.6. **TEMPORARY FACILITIES AND STAGING AREA.** The electrical energy and the water consumed shall be provided by the Government at no cost to the Contractor from existing lines and sources located in the ATCT or from services adjacent to the work areas. Contractor's use of utilities shall be coordinated with the Government. Contractor is responsible for ensuring that adequate electrical power and water are available to complete the work. The Contractor will be permitted to use the areas as directed by the Government for staging and storage of materials. The area is restricted to uncontaminated work equipment and supplies. The area shall be left clean and restored to the same condition as when accepted by the Contractor.
- 1B.7 **MEDICAL REQUIREMENTS.** Contractor shall provide medical surveillance and have a written Respiratory Protection program in place as required by OSHA 29 CFR 1910.134 for all personnel engaged in the removal and demolition of MCM and MCE. Respirators and filters provided shall be NIOSH approved and provide the appropriate level of protection.
- 1B.8 **PROTECTIVE CLOTHING.** Contractor shall provide workers and government representatives with sufficient sets of protective full body clothing. Such clothing shall consist of full body coveralls including head covers, foot covers and hand covers. Contractor shall provide additional personal protection safety equipment as required by applicable OSHA safety regulations. Contractor shall ensure that all employees who will conduct mold remediation activities are provided with, fit tested for, and trained in the correct use of personal protection equipment.
- 1B.9 **REMEDIATION AREA.** Contractor shall establish a remediation area and restrict the access to the microbiological work areas during work conducted in the ATCT. Contractor shall establish a roped-off perimeter and provide warning barrier tape and signs outside the perimeter of the negative pressure enclosure system. Contractor shall establish a negative pressure enclosure system by sealing all critical penetrations or openings to the work area with a minimum of two layers of six-mil polyethylene. Negative pressure enclosures shall have a minimum of four air exchanges per hour and shall be maintained and recorded with a magnehelic gauge or equivalent device under a minimum negative pressure differential of -0.02 inches of water relative

to adjacent non-work area space. Negative air pressure equipment shall be equipped with a HEPA filter and exhaust shall be discharged outside the building, a minimum of 25 feet from building access points and building make-up air sources, or wherever necessary, negative air pressure equipment shall be equipped with a HEPA filter and exhaust shall be discharged through a second HEPA filter in order to permit recirculation of air inside the building. Personnel shall wear and utilize protective clothing and equipment in the remediation area as specified herein.

- 1B.10 DECONTAMINATION AREA.** Contractor shall establish a decontamination unit for passage to and from the work area during remediation operations in order to minimize the leakage of mold-contaminated dust to the outside. This unit shall consist of a minimum of two chambers, including a clean room and equipment room separated by airlocks. The airlocks shall be formed by overlapping three sheets of 6-mil polyethylene sheeting at the exit of one room and three sheets at the entrance to the next room, with three feet of space between the barriers. Airlocks shall be constructed to effectively maintain negative pressure while not inhibiting worker egress in an emergency situation.
- 1B.11 WORKER PROTECTION PROCEDURE.**
- A. Each worker and authorized visitor shall, upon entering the job site, put on appropriate respirator and clean protective clothing, before entering the work area.
 - B. Each worker and authorized visitor shall remove gross contamination from clothing by HEPA vacuuming, prior to leaving the remediation work area. After decontamination of protective clothing, while still wearing the respirator, remove protective clothing and dispose as microbiological waste, as appropriate, in a drum or two layers of 6-mil polyethylene disposal bags.
 - C. Workers shall not eat, drink, smoke, or chew gum or tobacco at the work site. Workers shall be fully protected with respirators and protective clothing immediately prior to the first disturbance of MCM or MCE and until final cleanup is completed.
- 1B.12 AIR MONITORING AND INSPECTION.** The Government-retained Industrial Hygienist will determine any requirement for air monitoring, both during the remediation process and/or upon completion of the remediation process. Such area sampling will be conducted using Zefon filters and a high volume sampling pump. Procedural modifications to the decontamination procedures may be necessary at the discretion of the Government-retained Industrial Hygienist. The Government has the right to inspect the remediation work at times to be determined by the Government, but, at a minimum, once upon completed removal of contaminated materials, but before restoration materials are installed.
- 1B.13 FINAL CLEARANCE.** Acceptance of work will be dependant upon visual inspection. In areas where the gypsum board removal quantity exceeds 100 square feet, clearance air sampling shall also be conducted. The Contractor shall notify the Government when the microbiological removal is completed for each phase and the Government-retained Industrial Hygienist shall perform a thorough visual inspection of the phase within 24-hours. Clearance air sampling shall be conducted in Rooms 928 and 428. Clearance criteria shall be dependent upon the requirements stipulated in the DTW ATCT Mold Remediation Project Clearance Protocol attached and incorporated herein (See Attachment 2). All remaining rooms shall be clearly solely by visual examination.
- 1B.14 DISPOSAL.** All microbiological waste shall be disposed of at a municipal sanitary landfill. Waste bags shall not be overloaded and shall be securely sealed and stored in the designated area until disposal. Label bags, disposal containers, and truck during loading and unloading, in accordance with Federal, State and Local regulations. Contractor is responsible for removal of all materials from the Government's property.

- 1B.15 **INGRESS AND EGRESS TO WORK AREA.** The Resident Engineer shall direct all ingress and egress to the work area. Security precautions against unauthorized facility entrance will be maintained.
- 1B.16 **SECURITY REQUIREMENTS.** The Airport Traffic Control Tower (ATCT) facility is a secured facility and access to the interior is restricted to FAA personnel only. Therefore, all work included in this contract shall be coordinated to preclude interference with the operation of the facility. The contractor will coordinate this with the contracting officer through the Resident Engineer. The contractor shall examine the premises and satisfy himself/herself as to the existing conditions under which he/she will be obligated to perform the work included in this contract.
- 1B.17 **PARKING OF CONTRACTOR VEHICLES.** All personnel will park their vehicles away from the building and all access doors or as authorized by the Resident Engineer. Materials and tools may be off-loaded at the work site by arrangement with the Resident Engineer.
- 1B.18 **STORAGE OF MATERIALS.** The contractor shall store all materials in a manner to protect them from all elements of the weather. Storage of reasonable quantities of material, supplies, and tools on site is permissible providing the Resident Engineer authorizes the location. The FAA is not responsible for the security of the materials, supplies and tools owned by the contractor.
- 1B.19 **COMPLIANCE WITH LOCAL CODES AND OTHER CODES.** The contractor shall comply with local and other codes of standard trade practices adopted by these contract documents. Where the requirements of the specifications and drawings exceed those of the local and adapted codes, the contractor shall comply with the requirements of the specifications and drawings.
- 1B.20 **CLEANING.**
- A. Working Area. The contractor shall keep the working area in a clean and proper condition. All rubbish and waste resulting from the execution of the work shall be removed at the end of each day or as directed by the Resident Engineer.
 - B. Waste Packing Materials. Immediately after unpacking, all packing material shall be removed from the building and the premises.
 - C. Final Cleanup. Upon completion of work and before final inspection, the contractor shall remove his working tools, equipment, debris, rubbish and unused materials from the building site.
 - D. Disposal. Disposal of rubbish and debris will be offsite and at no additional cost to the FAA or as directed by the Resident Engineer.
- 1B.21 **NON-INTERFERENCE WITH EXISTING FACILITY OPERATION.**
- A. Job Conditions. The access to the facility shall be kept unobstructed at all times. If any interference with the existing facility operation or access seems to be unavoidable, the contractor shall advise the contracting officer through the Resident Engineer 24 hours before such interference. FAA reserves the right to stop work at any time if the operation of this facility is jeopardized by the contractor's work.
 - B. Equipment Shutdown. Each ATCT facility maintains air traffic control continuously without shutdown. Various techniques are employed to achieve maximum system availability. Mechanical and electrical systems in direct support of air traffic operation and environmental systems have redundant configurations. Shutdown of equipment shall be scheduled with the Resident Engineer at least 24 hours prior to the control system installer's need. The reliability of mechanical and electrical systems is compromised when redundant equipment is not available. Every effort will be made by the FAA to allow work to be accomplished during the

installer's working hours; however, the Resident Engineer will restore equipment to service immediately after this period. FAA personnel shall accomplish equipment shutdown.

- 1B.22 **OTHER CONTRACTS.** The Government may undertake other contracts for additional work at or near the site of the work under this contract. The contractor shall fully cooperate with other contractors and with the Government employees and shall adapt scheduling and performing the work under this contract to accommodate the other work. The contractor shall not commit or permit any act that will interfere with performance of work by any other contractor or by Government employees.
- 1B.23 **CONTRACTOR'S LIABILITY.** Damage to the existing facility or equipment caused by the contractor shall be immediately reported to the FAA Resident Engineer without delay. The contractor shall be responsible for repairing or having repaired all damaged areas to the facility or equipment directly caused by contractor related work. All repairs shall be accomplished, without delay, at the contractor's expense to the satisfaction of the FAA Resident Engineer.
- 1B.24 **PERMITS.** The contractor shall be responsible for obtaining all city, county, etc., permits, if required, to complete the project, at no additional cost to the Government.
- 1B.25 **MATERIAL.** All equipment, material, and articles incorporated into the work covered by this contract shall be new and of the most suitable grade for the purpose intended, unless otherwise specifically provided in this contract.
- References in the specifications to material, articles, or patented processes by trade name, make, or catalog number, shall be regarded as establishing a standard of quality and shall not be construed as limiting competition. The contractor may, at his option, use any equipment, material, article, or process that, in the judgment of the Resident Engineer, is equal to that named in the specifications, unless otherwise specifically provided in this contract.
- A. **Brand Name Items.** The use of brand names or equal products in this specification does not constitute a requirement that they are the only materials that meet the specifications in this contract. They are used as an illustration of known acceptable sources or products.
- 1B.26 **WORKMANSHIP.** The contract shall be accomplished by workers experienced in each trade in accordance with the highest standards of the various trades involved. The FAA Resident Engineer must approve all details, to assure a professional and complete project, whether stated in the specifications or not. The Resident Engineer may require, in writing, that the contractor will remove from the work any employee the Resident Engineer deems incompetent, careless, or otherwise objectionable.
- 1B.27 **SUPERINTENDENCE BY THE CONTRACTOR.** At all times during performance of this contract and until the work is completed and accepted, the contractor shall directly superintend the work on site or assign and have on site a competent superintendent who is satisfactory to the Resident Engineer and has authority to act for the contractor.
- 1B.28 **WARRANTIES.** The contractor shall guarantee that all works performed under this contract to be free from defects in all material and workmanship for a period of 12 months from the date of final acceptance by the Government.
- 1B.29 **RESPONSIBILITIES.** If within the warranty period, such parts or work performed under this contract is found to be defective in materials or workmanship, the contractor immediately without any additional cost to the Government shall replace that portion of work.

SECTION 1C - SUBMITTALS

- 1C.1 **INTRODUCTION.** Each product required for use in the contract drawings and specifications must meet the actual minimum needs of the Government as demonstrated in the salient characteristics

for that product. If a brand name product is used in the drawings or specifications, it should be regarded as a "known acceptable source". The product used can be identical or equal to the brand name product or known acceptable source in meeting the salient characteristics, but it need not exceed the actual minimum requirements. Any brand name product or known acceptable source mentioned will, however, not be required for use in order to comply with the specification or drawing unless those documents make it clear that the brand name product is required, and substitution is prohibited.

- 1C.2 **REQUIREMENTS.** The Contracting Officer or his/her designee must approve each product that a Contractor wishes to use that is not a known acceptable source, before use. To gain approval, the Contractor must submit documents and/or samples that will demonstrate the product clearly will meet the Government's minimum needs, and demonstrates appropriate salient characteristics. All submittals must be in writing. The Contracting Officer shall have the right to require submittals from the Contractor where the Contractor makes an unsolicited change proposal.

The information presented in a submittal shall be sufficient to demonstrate that all specification requirements for the subject material, equipment, methods, or plans, are met by the Contractor's proposal.

- 1C.3 **SUBMITTAL REVIEW.** When submitting before the Notice to Proceed date, the Contractor shall send the submittal package(s) directly to the Contracting Officer. When submitting after Contract work has begun, the Contractor shall give submittal packages to the Resident Engineer, who will forward them promptly to the Contracting Officer. In either case, the submittal will return directly from the Contracting Officer to the Contractor, with the Contracting Officer's approval, approval with comments, or disapproval.

- 1C.4 **SUBMITTAL TIME FRAME.** To provide adequate time for document transmission and submittal review, the FAA reserves the right to take ten days to complete a review, transmission date to transmission date. Since this Contract has a short duration, the Contractor is urged to initiate submittals along with his/her bid and to in general to expedite document transmission. The Contracting Officer will expedite reviews and document transmission to the extent that it is feasible.

1C.5 **SUBMITTALS**

- A. The contractor shall submit all the following:
1. Work Plan
 2. Safety Program
 3. Certificate of training, accreditation, qualification
 4. List of Employees
 5. Proof of Insurance
 6. Material Safety Data Sheets for all chemical products.
 7. Respiratory Fit Test and Medical Surveillance for employees scheduled for this project.
 8. Negative Air HEPA Filtration Equipment Specification Sheet
 9. Proposed Phasing Schedule.

- B. All required submittals shall be provided to the Contracting Officer at the following address:

FEDERAL AVIATION ADMINISTRATION
2300 East Devon Ave.
Des Plaines, IL 60018

- 1C.6 **OTHER ITEMS.** Any notification to any regulatory agency whether federal, state or local is the responsibility of the Mold abatement contractor. A copy of any notification is to be provided to the RE for record retention.

- 1C.7 **PROCUREMENT BEFORE APPROVAL.** The Contractor is advised not to procure any item for which submittal approval is required but not yet granted. If approval is denied, the Contractor will be prevented from installing the disapproved item(s). The Contractor must transmit a new submittal package for the new items replacing the disapproved items, and must procure only approved items. The Contractor shall take responsibility for the delivery and installation of any items installed before submittal approval is granted. The FAA reserves the right to discontinue fieldwork on any item furnished without submittal approval.
- 1C.8 **CONTRACTOR QUALIFICATION REQUIREMENTS.** The contractor shall provide all the services, equipment, supplies, materials, and labor required to remediate, remove, replace drywall & insulation, and dispose all waste. The abatement contractor must comply with the following:
- A. All work shall be done under the direct supervision of a professional with experience and training in mold remediation.
 - B. The contractor shall coordinate and prepare a schedule to be approved by the Resident Engineer for conducting the remediation at DTW ATCT.
 - C. Prior to the scheduled pre-construction meeting the contractor shall provide copies of all MSDS sheets for any chemicals and other products that have been authorized by the FAA that will be brought on site and used during this project.
 - D. No chemical cleaners, disinfectants, mold inhibitors, fungicides, encapsulants, spray adhesives, odor masking agents, air fresheners or similar materials are authorized for use during this project and may not be brought onsite. When approved by the FAA prior to use, small quantities of low odor consumer type hand dishwashing detergent may be used when mixed with water for the purpose of wetting cleaning cloths used for damp wiping surfaces.
 - E. The surfaces of the room shall be HEPA vacuumed or damp wiped, and then covered prior to the start of any mold remediation work.
 - F. All 6-mil polyethylene sheeting is to be fire retardant.
 - G. The contractor shall notify the RE **IMMEDIATELY** if any conditions are identified during the remediation, which may require immediate attention to prevent potential exposure to mold at the facility.
 - H. Security and insurance requirements: The ATCT's are secured facilities and all personnel entering the facility shall meet all security and insurance requirements for gaining access to the individual facility. Insurance requirements are listed below:

SECTION 1D - ABATEMENT

1D.1 SECURITY.

The DTW ATCT is under security at all times. All critical areas (ATCT tower and base building) are controlled and security must be maintained. The contractor will provide a list of all personnel that will be entering the facility to do abatement work, to the CO/COR/RE.

The abatement Contractor shall maintain a logbook documenting entry into and out of the regulated work area. The Contractor shall not allow unauthorized personnel access to the site. Authorized personnel include the Abatement Contractor and his/her workers, CO and his/her representatives, the Environmental Contractor, representatives of regulatory agencies having jurisdiction over the project, FAA bargaining unit representatives and fire or medical response personnel in the event of emergency. No other person(s) may enter the areas occupied by the contractor or his/her equipment without submitting evidence of completion of required medical examinations and respirator training to the COTR/RE prior to entering the abatement areas.

All facility-specific security procedures will be followed.

1D.2 Drywall Removal.

- A. Remove drywall to the extent indicated on the drawings. Drywall shall be cut away through the use of a spiral cutting saw equipped with a close capture exhaust system attached to a HEPA filtered vacuum for dust control. The cutting depth of the spiral saw will be adjusted to a depth slightly less than the thickness of the drywall. Final cutting of the scored drywall will be made with a razor knife to avoid release of dust into the wall cavity and to prevent damage to concealed equipment, or additional layers of wall board that are present. In areas where access restrictions prevent use of the spiral saw, hand saws may be used, but only while a HEPA filtered vacuum is used to capture dust at the point of generation. Reciprocating saws shall not be used.

DIVISION 9 - FINISHES
SECTION 9A - GYPSUM BOARD

9A.1 - GENERAL

- A. RELATED DOCUMENTS. Drawings and general provisions of the Contract, including General and Supplementary Conditions and Division 1 - General Requirements, apply to this section.
- B. SUMMARY. Scope: This section includes, but shall not be limited to, non-load-bearing steel framing members for gypsum board assemblies and gypsum board assemblies attached to steel framing.
- C. REFERENCES. The publications listed below for a part of this specification to the extent referenced. The publications are referred to in the text by the basic designation only. The edition/revision of the referenced publications shall be the latest date as of the date of the Contract Documents, unless otherwise specified.
1. American Society of Testing and Materials (ASTM)
 - a) ASTM C 36 "Standard Specification for Gypsum Wallboard".
 - b) ASTM C 442 "Standard Specification for Gypsum Backing Board and Coreboard".
 - c) ASTM C 475 "Standard Specification for Joint Compound and Joint Tape for Finishing Gypsum Board".
 - d) ASTM C 630 "Standard Specification for Water-Resistant Gypsum Backing Board".
 - e) ASTM C 840 "Standard Specification for Application and Finishing of Gypsum Board".
 - f) ASTM C 1047 "Standard Specification for Accessories for Gypsum Wallboard and Gypsum Veneer Base".
 2. Gypsum Association (GA)
 - a) GA 214 "Recommended Specification: Levels of Gypsum Board Finish".
 - b) GA 216 "Application and Finishing of Gypsum Board".
 - c) GA 505 "Gypsum Board Terminology".
 - d) GA 600 "Fire Resistance Design Manual".
 3. Underwriters Laboratories, Inc. (UL)
 - a) UL FRD "Fire Resistance Directory".
- D. ASSEMBLY PERFORMANCE REQUIREMENTS
1. Performance Requirements, General: Provide gypsum board systems complying with performance requirements specified, as demonstrated by pre-testing manufacturer's corresponding stock system.
 2. Fire Resistance Rating: Where indicated, provide materials and construction which are identical to those of assemblies whose fire resistance has been determined per ASTM E 119 by a testing and inspection organization acceptable to authorities having jurisdiction.
 - a) Provide fire resistance-rated assemblies identical to those indicated by reference to file numbers in GA 600 or to design designations in UL FRD or in listings of other testing and inspecting agencies acceptable to authorities having jurisdiction.
 3. Sound Transmission Characteristics: For gypsum board assemblies indicated to have STC ratings, provide materials and construction identical to those of assemblies whose STC ratings were determined per ASTM E 90 and classified per ASTM E 413 by a qualified independent testing agency. Provide the following minimum ratings for sound transmission class (STC):
 - a) STC Rating: As indicated but not less than 35.

A. SUBMITTALS

1. General: Submit the following in accordance with Conditions of the Contract and Division 1 – General Requirements.
2. Product Data: Submit product data for each type of product specified including, but not limited to, standard details, specifications, installation instructions, and general manufacturer's recommendation.
3. Shop Drawings: Submit shop drawings of unusual conditions in connection with gypsum board construction not specifically shown in manufacturer's product data. Provide elevations and reflected ceiling plans indicating proposed locations for expansion and control joints.
4. Samples: Submit 12 inch (305 mm) square sample boards showing each trim, reveal, control joint, inside and outside corner condition, and typical taped and floated joint. Show intersections, corners, tees, and splices on each sample.
5. Product Certificates: Submit product certificates signed by manufacturers of gypsum board assembly components certifying that their products comply with specified requirements.
6. Product Test Reports: Submit test reports indicating and interpreting test results relative to compliance of gypsum board assemblies with fire resistance, structural performance, and acoustical performance requirements.
7. Research Reports: Submit research reports or evaluation reports of the model code organization acceptable to authorities having jurisdiction which evidence gypsum board assembly's compliance with requirements and with building code in effect for the Project.

B. QUALITY ASSURANCE

1. Single Source Responsibility:
 - a) Steel Framing: Obtain steel framing members for gypsum board assemblies from a single manufacturer.
 - b) Panel Products: Obtain each type of gypsum board and other panel products from a single manufacturer.
 - c) Finishing Materials: Obtain finishing materials from wither the same manufacturer that supplies gypsum board and other panel products or from a manufacturer acceptable to gypsum board manufacturer.
2. Field Samples: On actual gypsum board assemblies, prepare field samples of at least 100 square feet (9.3 m²) in surface area for the following applications. Simulate finished lighting conditions for review on in-place unit work.
 - a) Wall surfaces indicated to receive non-textured paint finishes.
 - b) Ceiling surfaces indicated to receive non-textured paint finishes.
3. Pre-Installation Conference: Conduct pre-installation conference at the Project site to comply with requirement of Division 1 – General Requirements.

C. DELIVERY, STORAGE, AND HANDLING

1. Deliver materials in original packages, containers, or bundles bearing brand name and identification of manufacturer or supplier.
2. Store materials inside under cover and keep them dry and protected against damage from weather, direct sunlight, surface contamination, corrosion, construction traffic, and other causes. Neatly stack gypsum panels flat to prevent sagging.
3. Handle gypsum board to prevent damage to edges, ends, and surfaces. Do not bend or otherwise damage metal corner beads and trim.

D. PROJECT CONDITIONS

1. Environmental Conditions, General: Establish and maintain environmental conditions for applying and finishing gypsum board to comply with ASTM C 840 and with gypsum board manufacturer's recommendations.
2. Room Temperatures: For attachment of gypsum board to framing, maintain not less than 40° F (4° C). For finishing of gypsum board, maintain not less than 50° F (10° C) for 48 hours prior to application and continuously after until dry. Do not exceed 95° F (35° C) when using temporary heat sources.
3. Ventilation: Ventilate building spaces, as required, for drying joint treatment materials. Avoid drafts during hot dry weather to prevent finishing materials from drying too rapidly.

9A.2 Products

A GYPSUM BOARD PRODUCTS

1. General: Provide gypsum board of types indicated in maximum lengths available to minimize end-to-end butt joints.
 - a) Thickness: Provide gypsum board in thickness indicated or, if not otherwise indicated, in either ½ inch (13 mm) or 5/8 inch (16 mm) thickness to comply with ASTM C 840 for application system and support spacing indicated.
2. Gypsum Wallboard: Comply with ASTM C36 and as follows:
 - a) Typed:
 - i. Regular for vertical surfaces, unless otherwise indicated.
 - ii. Type X where required for fire resistive-rated assemblies.
 - iii. Sag-resistant type for ceiling surfaces.
 - b) Edges: Tapered
 - c) Thickness: 5/8 inch (16 mm), unless otherwise indicated.
3. Gypsum Backing Board for Multi-Layer Applications: Comply with ASTM C 442 or, where backing board is not available from manufacturer, gypsum wallboard complying with ASTM C 36, and as follows:
 - a) Type:
 - i. Regular for vertical surfaces, unless otherwise indicated.
 - ii. Type X where indicated or required for fire resistive-rated assemblies.
 - iii. Sag-resistant type for ceiling surfaces, unless otherwise indicated.
 - b) Edges: Manufacturer's standard.
 - c) Thickness: 5/8 inch (16 mm), unless otherwise indicated.
4. Water-resistant Gypsum Backing Board: Comply with ASTM C 630 and as follows:
 - a) Type:
 - i. Regular, unless otherwise indicated.
 - ii. Type X where required for fire resistive-rated assemblies.
 - b) Thickness: 5/8 inch (16 mm), unless otherwise indicated.

B. CEMENTITIOUS BACKER UNITS

1. General: Provide cementitious backer units complying with ANSI A118.9, of thickness and width indicated below, and in maximum lengths available to minimize end-to-end butt joints.
 - a) Thickness: 5/8 inch (16 mm), unless otherwise indicated.
 - b) Width: Manufacturer's standard width but not less than 32 inches (813 mm).

C. JOINT TREATMENT MATERIALS

1. General: Provide joint treatment materials complying with ASTM C 475 and the recommendations of both the manufacturers of sheet products and of joint treatment materials for each application indicated.

2. Joint Tape for Gypsum Board: Provide paper reinforcing tape, unless otherwise indicated.
 - a. Use pressure sensitive or staple-attached open weave glass fiber reinforcing tape with compatible joint compound where recommended by manufacturer of gypsum board and joint treatment materials for application indicated.
3. Joint Tape for Cementitious for Backer Units: Provide polymer-coated, open glass fiber mesh.
4. Setting Type Joint Compounds for Gypsum Board: Provide factory-packaged, job-mixed, chemical hardening powder products formulated for uses indicated.
 - a. Where setting type joint compounds are indicated as a taping compound only or for taping and filling only, use formulation that is compatible with other joint compounds applied over it.
 - b. For pre-filling gypsum board joints, use formulation recommended by gypsum board manufacturer for this purpose.
 - c. For filling joints and treating fasteners of water-resistant gypsum backing board behind base for ceramic tile, use formulation recommended by the gypsum board manufacturer for this purpose.
 - d. For topping compound, use sandable formulation.
5. Drying Type Joint Compounds for Gypsum Board: Provide factory-packaged vinyl-based products complying with the following requirements for formulation and intended use.
 - a. Ready-Mixed Formulation: Factory-mixed product.
 - b. Topping Compound: Topping compound formulated for fill (second) and finish (third) coats.
 - c. All-Purpose Compound: All-purpose compound formulated for both taping and topping compounds.
6. Joint Compound for Cementitious Backer Unit: Provide material recommended by cementitious backer unit manufacturer.

D ACOUSTICAL SEALANT

1. Latex Acoustical Sealant: Provide manufacturer's standard nonsag, paintable, nonstaining latex sealant complying with ASTM C 834 and the following requirements:
 - a. Product is effective in reducing airborne sound transmission through perimeter joints and openings in building construction as demonstrated by testing representative assemblies per ASTM E 90.
 - b. Product has flame spread and smoke developed ratings of less than 25 per ASTM E 84.
 - ii. Acoustical Sealant for Concealed Joints: Provide manufacturer's standard nondrying, nonhardening, nonskinning, nonstaining, gunnable, synthetic rubber sealant recommended for sealing interior concealed joints to reduce transmission of airborne sound.

E. MISCELLANEOUS MATERIALS

1. General: Provide auxiliary materials for gypsum board construction that comply with referenced standards and recommendations of gypsum board manufacturer
2. Spot Grout: Comply with ASTM C 475, setting type joint compound recommended for spot grouting hollow metal doorframes.
3. Screws:
 - a. Provide steel drill screws complying with ASTM C 1002 for the following applications:
 - i. Fastening gypsum board to steel members less than 0.03 inch (0.76 mm) thick.
 - ii. Fastening gypsum board to gypsum board.
 - b. Provide steel drill screws complying with ASTM C 954 for fastening gypsum board to steel members from 0.033 inch (0.84 mm) to 0.112 inch (2.84 mm) thick.

- c. Provide corrosion-resistant coated steel drill screws of size and type recommended by board manufacturer for fastening cementitious backer units.
- 4. Asphalt-Saturated Organic Felt: Comply with ASTM D 226, Type I (No. 15 asphalt felt), non-perforated.
- 5. Sound Attenuation Blankets: Provide un-faced mineral fiber blanket insulation produced by combining mineral fibers manufactured from glass or slag with thermosetting resins to comply with ASTM C 665 for Type I (blankets without membrane facing).

9A.3 Execution

A. EXAMINATION

- 1. Examine substrates to which gypsum board assemblies attach or abut, installed hollow metal frames, and structural framing, with the Installer present, for compliance with requirements for installation tolerances and other conditions affecting performance of assemblies specified in this section. Do not proceed with installation until unsatisfactory conditions have been corrected.

B. PREPARATION

- 1. Before sprayed-on fireproofing is applied, attach offset anchor plates or ceiling runners (tracks) to surfaces indicated to receive spray-on fireproofing. Where offset anchor plates are required, provide continuous units fastened to building structure not more than 24 inches (610 mm) on center.
- 2. After sprayed-on fireproofing has been applied, remove only as much sprayed-on fireproofing as needed to complete installation of gypsum board assemblies without reducing thickness of sprayed-on fireproofing below that required to obtain fire resistive rating indicated. Protect remaining sprayed-on fireproofing from damage.

C. APPLYING AND FINISHING GYPSUM BOARD, GENERAL

- 1. Install and finish gypsum panels to comply with ASTM C 840 and GA 216.
- 2. Install sound attenuation blankets where indicated prior to installing gypsum panels unless blankets are readily installed after panels have been installed on one side.
- 3. Install wall/partition board panels to minimize the number of abutting end joints or avoid them entirely. Stagger abutting end joints not less than one framing member in alternate courses of board. At stairwells and other high walls, install panels horizontally with end abutting joints over studs and staggered.
- 4. Install gypsum panels with face side out. Do not install imperfect, damaged, or damp panels. Butt panels together for a light contact at edges and ends with not more than 1/16 inch (1/6 mm) of open space between panels. Do not force into place.
- 5. Locate both edge or end joints over supports, except in ceiling applications where intermediate supports or gypsum board back blocking is provided behind end joints. Position adjoining panels so that tapered edges abut tapered edges, and field-cut edges abut field-cut edges and ends. Do not place tapered edges against cut edged or ends. Stagger vertical joints over different studs on opposite sides of partitions. Avoid joints at corners of framed openings where possible.
- 6. Attach gypsum panels to steel studs so that the leading edge or end of each panel is attached to open (unsupported) edges of stud flanges first.
- 7. Attach gypsum panels to framing provided at openings and cutouts.
- 8. Spot grout hollow metal door frames for solid core wood doors, hollow metal doors, and doors over 32 inches (813 mm) wide. Apply spot grout at each jamb anchor clip and immediately insert gypsum panels into frames.
- 9. Form control joints and expansion joints at locations indicated and as detailed, with space between edges of adjoining gypsum panels, as well as supporting framing behind gypsum panels.

10. Cover both faces of steel stud partition framing with gypsum panels in concealed spaces (above ceilings, etc.) except in chase walls that are braced internally.
 - a. Except where concealed application is indicated or required for sound, fire, air, or smoke ratings, coverage may be accomplished with scraps of not less than 8 square feet (0.74m²) in area.
 - b. Fit gypsum panels around ducts, pipes, and conduits.
 - c. Where partitions intersect structural members projecting below underside of floor/roof slabs and decks cut gypsum panels to fit profile formed by structural members. Allow ¼ inch (6 mm) to ½ inch (13 mm) wide joints to install sealant.
11. Isolate perimeter of non-load-bearing gypsum board partitions a structural abutment, except floors, as detailed. Provide ¼ inch (6 mm) to ½ inch (13 mm) wide spaces at these locations and trim edges with U-bead edge trim where edges of gypsum panels are exposed. Seal joints between edges and abutting structural surfaces with acoustical sealant.
12. Where STC-rated gypsum board assemblies are indicated, seal construction at perimeters, behind control and expansion joints, openings, and penetrations with a continuous bead of acoustical sealant including a bead at both faces of the partitions. Comply with ASTM C 919 and manufacturer's recommendations for location of edge trim and closing off sound flanking paths around or through gypsum board assemblies, including sealing partitions above acoustical ceilings.
13. Space fasteners in gypsum panels according to referenced gypsum board application and finishing standard and manufacturer's recommendations.

G. GYPSUM BOARD APPLICATION METHODS

1. Single-Layer Application: Install gypsum wallboard panels as follows:
 - a. On partitions/walls, apply gypsum panels horizontally (perpendicular to framing), unless parallel application is required for fire resistive-rated assemblies. Use maximum length panels to minimize end joints.
2. Double-Layer Application: Install gypsum backing-board for base layers and gypsum wallboard for face layers.
 - a. On partitions/walls, apply base layers and face layers vertically (parallel to framing) with joints of base layers located over stud or furring member and face layer joints offset at least one stud or furring member with base layer joints. Stagger joints on opposite sides of partitions.
3. Single-Layer Fastening Methods: Apply gypsum panels to supports with screws.
4. Double-Layer Fastening Methods: Apply base layer of gypsum panels and face layer to base layer as follows:
 - a. Fasten both base layers and face layers separately to supports with screws.

H. FINISHING GYPSUM BOARD ASSEMBLIES

1. Apply joint treatment at gypsum board joints (both directions); flanges of corner bead, edge trim, and control joints; penetrations; and fastener heads, surface defects, and elsewhere as required to prepare gypsum board surfaces for decoration and levels of gypsum board finish indicated.
2. Pre-fill open joints, rounded or beveled edges, and damaged areas using setting type joint compound.
3. Apply joint tape over gypsum board joints except those with trim accessories having concealed face flanges not requiring taping to prevent cracks from developing in joint treatment at flange edges.
4. Provide the following levels of gypsum board finish per GA 214.
 - a. Level 1 for ceiling plenum areas, concealed areas, and where indicated, unless a higher level of finish is required for fire resistive rated assemblies and sound-rated assemblies.
 - b. Level 2 where water-resistant gypsum backing board panels from substrates for tile, and where indicated.

- c. Level 4 for gypsum board surfaces indicated to receive wall coverings.
 - d. Level 5 for gypsum board surfaces indicated to receive gloss and semi-gloss enamels, non-textured flat paints, and where indicated.
5. For Level 4 gypsum board finish, embed tape in finishing compounds plus two separate coats applied over joints, angles, fastener heads, and trim accessories using the following combination of joint compounds (not including pre-fill), and sand between coats and after last coat:
 - a. Embedding and First Coat: Setting type joint compound.
 - b. Fill (second) Coat: Setting type joint compound.
 - c. Finish (Third) Coat: Ready-mixed, drying type, all purpose or topping compound.
 6. Where Level 5 gypsum board finish is indicated, apply joint compound combination specified for Level 4 plus a thin, uniform skim coat of joint compound over entire surface. Use joint compound specified for the finish (third coat) or a product specially formulated for this purpose and acceptable to gypsum board manufacturer. Produce surfaces free of tool marks and ridges ready for decoration of type indicated.
 7. Where Level 2 gypsum board finish is indicated, apply joint compound specified for first coat in addition to embedding coat.
 8. Where Level 1 gypsum board finish is indicated, apply joint compound specified for embedding coat.
 9. Finish water-resistant gypsum backing-board forming base for ceramic tile to comply with ASTM C 840 and board manufacturer's directions for treatment of joint behind tile.
 10. Finish cementitious backer units to comply with unit manufacturer's directions.
- I. CLEANING AND PROTECTION
 1. Promptly remove any residual joint compound from adjacent surfaces.
 2. Provide final protection and maintain conditions, in a manner suitable to the installer that shall ensure gypsum board assemblies shall remain without damage or deterioration at time of Substantial Completion.

ATTACHMENT 1

**Guidelines on Assessment and Remediation of
Fungi in Indoor Environments**



ATTACHMENT 2

DTW ATCT MOLD REMEDIATION PROJECT CLEARANCE PROTOCOL



Go Back to DOHMH Page

Fungi in Indoor Environments : Environmental & Occupational Disease Epidemiology : NYC DOHMH

EODE

Guidelines on Assessment and Remediation of Fungi in Indoor Environments

- Executive Summary
- Introduction
- Health Issues
- Environmental Assessment
- Remediation
- Hazard Communication
- Conclusion
- Notes and References
- Acknowledgments

Executive Summary

On May 7, 1993, the New York City Department of Health (DOH), the New York City Human Resources Administration (HRA), and the Mt. Sinai Occupational Health Clinic convened an expert panel on *Stachybotrys atra* in Indoor Environments. The purpose of the panel was to develop policies for medical and environmental evaluation and intervention to address *Stachybotrys atra* (now known as *Stachybotrys chartarum* (SC)) contamination. The original guidelines were developed because of mold growth problems in several New York City buildings in the early 1990's. This document revises and expands the original guidelines to include all fungi (mold). It is based both on a review of the literature regarding fungi and on comments obtained by a review panel consisting of experts in the fields of microbiology and health sciences. It is intended for use by building engineers and management, but is available for general distribution to anyone concerned about fungal contamination, such as environmental consultants, health professionals, or the general public.

We are expanding the guidelines to be inclusive of all fungi for several reasons:

- Many fungi (e.g., species of *Aspergillus*, *Penicillium*, *Fusarium*, *Trichoderma*, and *Memnoniella*) in addition to SC can produce potent mycotoxins, some of which are identical to compounds produced by SC. Mycotoxins are fungal metabolites that have been identified as toxic agents. For this reason, SC cannot be treated as uniquely toxic in indoor environments.
- People performing renovations/cleaning of widespread fungal contamination may be at risk for developing Organic Dust Toxic Syndrome (ODTS) or Hypersensitivity Pneumonitis (HP). ODTS may occur after a *single heavy* exposure to dust contaminated with fungi and produces flu-like symptoms. It differs from HP in that it is not an immune-mediated disease and does not require repeated exposures to the same causative agent. A variety of biological agents may cause ODTS including common species of fungi. HP may occur after repeated exposures to an allergen and can result in permanent lung damage.
- Fungi can cause allergic reactions. The most common symptoms are runny nose, eye irritation, cough, congestion, and aggravation of asthma.

Fungi are present almost everywhere in indoor and outdoor environments. The most common symptoms of fungal exposure are runny nose, eye irritation, cough, congestion, and aggravation of asthma. Although there is evidence documenting severe health effects of fungi in humans, most of this evidence is derived from ingestion of contaminated foods (i.e., grain and peanut products) or occupational exposures in agricultural settings where inhalation exposures were very high. With the possible exception of remediation to very heavily contaminated indoor environments, such high-level exposures are not expected to occur while performing remedial work.

There have been reports linking health effects in office workers to offices contaminated with moldy surfaces and in residents

of homes contaminated with fungal growth. Symptoms, such as fatigue, respiratory ailments, and eye irritation were typically observed in these cases. Some studies have suggested an association between SC and pulmonary hemorrhage/hemosiderosis in infants, generally those less than six months old. Pulmonary hemosiderosis is an uncommon condition that results from bleeding in the lungs. The cause of this condition is unknown, but may result from a combination of environmental contaminants and conditions (e.g., smoking, fungal contaminants and other bioaerosols, and water-damaged homes), and currently its association with SC is unproven.

The focus of this guidance document addresses mold contamination of building components (walls, ventilation systems, support beams, etc.) that are chronically moist or water damaged. Occupants should address common household sources of mold, such as mold found in bathroom tubs or between tiles with household cleaners. Moldy food (e.g., breads, fruits, etc.) should be discarded.

Building materials supporting fungal growth must be remediated *as rapidly as possible* in order to ensure a healthy environment. Repair of the defects that led to water accumulation (or elevated humidity) should be conducted in conjunction with or prior to fungal remediation. Specific methods of assessing and remediating fungal contamination should be based on the extent of visible contamination and underlying damage. The simplest and most expedient remediation that is reasonable, and properly and safely removes fungal contamination, should be used. Remediation and assessment methods are described in this document.

The use of respiratory protection, gloves, and eye protection is recommended. Extensive contamination, particularly if heating, ventilating, air conditioning (HVAC) systems or large occupied spaces are involved, should be assessed by an experienced health and safety professional and remediated by personnel with training and experience handling environmentally contaminated materials. Lesser areas of contamination can usually be assessed and remediated by building maintenance personnel. In order to prevent contamination from recurring, underlying defects causing moisture buildup and water damage must be addressed. Effective communication with building occupants is an essential component of all remedial efforts.

Fungi in buildings may cause or exacerbate symptoms of allergies (such as wheezing, chest tightness, shortness of breath, nasal congestion, and eye irritation), especially in persons who have a history of allergic diseases (such as asthma and rhinitis). Individuals with persistent health problems that appear to be related to fungi or other bioaerosol exposure should see their physicians for a referral to practitioners who are trained in occupational/environmental medicine or related specialties and are knowledgeable about these types of exposures. Decisions about removing individuals from an affected area must be based on the results of such medical evaluation, and be made on a case-by-case basis. Except in cases of widespread fungal contamination that are linked to illnesses throughout a building, building-wide evacuation is not indicated.

In summary, prompt remediation of contaminated material and infrastructure repair is the primary response to fungal contamination in buildings. Emphasis should be placed on preventing contamination through proper building and HVAC system maintenance and prompt repair of water damage.

This document is not a legal mandate and should be used as a guideline. Currently there are no United States Federal, New York State, or New York City regulations for evaluating potential health effects of fungal contamination and remediation. These guidelines are subject to change as more information regarding fungal contaminants becomes available.

top of page

Introduction

On May 7, 1993, the New York City Department of Health (DOH), the New York City Human Resources Administration (HRA), and the Mt. Sinai Occupational Health Clinic convened an expert panel on *Stachybotrys atra* in Indoor Environments. The purpose of the panel was to develop policies for medical and environmental evaluation and intervention to address *Stachybotrys atra* (now known as *Stachybotrys chartarum* (SC)) contamination. The original guidelines were developed because of mold growth problems in several New York City buildings in the early 1990's. This document revises and expands the original guidelines to include all fungi (mold). It is based both on a review of the literature regarding fungi and on comments obtained by a review panel consisting of experts in the fields of microbiology and health sciences. It is intended for use by building engineers and management, but is available for general distribution to anyone concerned about fungal contamination, such as environmental consultants, health professionals, or the general public.

This document contains a discussion of potential health effects; medical evaluations; environmental assessments; protocols for remediation; and a discussion of risk communication strategy. The guidelines are divided into four sections:

1. Health Issues; 2. Environmental Assessment; 3. Remediation; and 4. Hazard Communication.

We are expanding the guidelines to be inclusive of all fungi for several reasons:

- Many fungi (e.g., species of *Aspergillus*, *Penicillium*, *Fusarium*, *Trichoderma*, and *Memnoniella*) in addition to SC can produce potent mycotoxins, some of which are identical to compounds produced by SC.^{1, 2, 3, 4} Mycotoxins are fungal metabolites that have been identified as toxic agents. For this reason, SC cannot be treated as uniquely toxic in indoor environments.
- People performing renovations/cleaning of widespread fungal contamination may be at risk for developing Organic Dust Toxic Syndrome (ODTS) or Hypersensitivity Pneumonitis (HP). ODTS may occur after a *single heavy* exposure to dust contaminated with fungi and produces flu-like symptoms. It differs from HP in that it is not an immune-mediated disease and does not require repeated exposures to the same causative agent. A variety of biological agents may cause ODTS including common species of fungi. HP may occur after repeated exposures to an allergen and can result in permanent lung damage.^{5, 6, 7, 8, 9, 10}
- Fungi can cause allergic reactions. The most common symptoms are runny nose, eye irritation, cough, congestion, and aggravation of asthma.^{11, 12}

Fungi are present almost everywhere in indoor and outdoor environments. The most common symptoms of fungal exposure are runny nose, eye irritation, cough, congestion, and aggravation of asthma. Although there is evidence documenting severe health effects of fungi in humans, most of this evidence is derived from ingestion of contaminated foods (i.e., grain and peanut products) or occupational exposures in agricultural settings where inhalation exposures were very high.^{13, 14} With the possible exception of remediation to very heavily contaminated indoor environments, such high level exposures are not expected to occur while performing remedial work.¹⁵

There have been reports linking health effects in office workers to offices contaminated with moldy surfaces and in residents of homes contaminated with fungal growth.^{12, 16, 17, 18, 19, 20} Symptoms, such as fatigue, respiratory ailments, and eye irritation were typically observed in these cases.

Some studies have suggested an association between SC and pulmonary hemorrhage/hemosiderosis in infants, generally those less than six months old. Pulmonary hemosiderosis is an uncommon condition that results from bleeding in the lungs. The cause of this condition is unknown, but may result from a combination of environmental contaminants and conditions (e.g., smoking, other microbial contaminants, and water-damaged homes), and currently its association with SC is unproven.^{21, 22, 23}

The focus of this guidance document addresses mold contamination of building components (walls, ventilation systems, support beams, etc.) that are chronically moist or water damaged. Occupants should address common household sources of mold, such as mold found in bathroom tubs or between tiles with household cleaners. Moldy food (e.g., breads, fruits, etc.) should be discarded.

This document is not a legal mandate and should be used as a guideline. Currently there are no United States Federal, New York State, or New York City regulations for evaluating potential health effects of fungal contamination and remediation. These guidelines are subject to change as more information regarding fungal contaminants becomes available.

top of page

1. Health Issues

1.1 Health Effects

Inhalation of fungal spores, fragments (parts), or metabolites (e.g., mycotoxins and volatile organic compounds) from a wide variety of fungi may lead to or exacerbate immunologic (allergic) reactions, cause toxic effects, or cause infections.^{11, 12, 24}

There are only a limited number of documented cases of health problems from indoor exposure to fungi. The intensity of exposure and health effects seen in studies of fungal exposure in the indoor environment was typically much less severe than those that were experienced by agricultural workers but were of a long-term duration.^{5-10, 12, 14, 16-20, 25-27} Illnesses can result from both high level, short-term exposures and lower level, long-term exposures. The most common symptoms reported from exposures in indoor environments are runny nose, eye irritation, cough, congestion, aggravation of asthma, headache, and fatigue.^{11, 12, 16-20}

The presence of fungi on building materials as identified by a visual assessment or by bulk/surface sampling results does not necessitate that people will be exposed or exhibit health effects. In order for humans to be exposed indoors, fungal spores, fragments, or metabolites must be released into the air and inhaled, physically contacted (dermal exposure), or ingested. Whether or not symptoms develop in people exposed to fungi depends on the nature of the fungal material (e.g., allergenic, toxic, or infectious), the amount of exposure, and the susceptibility of exposed persons. Susceptibility varies with the genetic predisposition (e.g., allergic reactions do not always occur in all individuals), age, state of health, and concurrent exposures. For these reasons, and because measurements of exposure are not standardized and biological markers of exposure to fungi are largely unknown, it is not possible to determine "safe" or "unsafe" levels of exposure for people in general.

1.1.1 Immunological Effects

Immunological reactions include asthma, HP, and allergic rhinitis. Contact with fungi may also lead to dermatitis. It is thought that these conditions are caused by an immune response to fungal agents. The most common symptoms associated with allergic reactions are runny nose, eye irritation, cough, congestion, and aggravation of asthma.^{11, 12} HP may occur after repeated exposures to an allergen and can result in permanent lung damage. HP has typically been associated with repeated heavy exposures in agricultural settings but has also been reported in office settings.^{25, 26, 27} Exposure to fungi through renovation work may also lead to initiation or exacerbation of allergic or respiratory symptoms.

1.1.2 Toxic Effects

A wide variety of symptoms have been attributed to the toxic effects of fungi. Symptoms, such as fatigue, nausea, and headaches, and respiratory and eye irritation have been reported. Some of the symptoms related to fungal exposure are non-specific, such as discomfort, inability to concentrate, and fatigue.^{11, 12, 16-20} Severe illnesses such as ODTS and pulmonary hemosiderosis have also been attributed to fungal exposures.^{5-10, 21, 22}

ODTS describes the abrupt onset of fever, flu-like symptoms, and respiratory symptoms in the hours following a *single, heavy* exposure to dust containing organic material including fungi. It differs from HP in that it is not an immune-mediated disease and does not require repeated exposures to the same causative agent. ODTS may be caused by a variety of biological agents including common species of fungi (e.g., species of *Aspergillus* and *Penicillium*). ODTS has been documented in farm workers handling contaminated material but is also of concern to workers performing renovation work on building materials contaminated with fungi.⁵⁻¹⁰

Some studies have suggested an association between SC and pulmonary hemorrhage/hemosiderosis in infants, generally those less than six months old. Pulmonary hemosiderosis is an uncommon condition that results from bleeding in the lungs. The cause of this condition is unknown, but may result from a combination of environmental contaminants and conditions (e.g., smoking, fungal contaminants and other bioaerosols, and water-damaged homes), and currently its association with SC is unproven.^{21, 22, 23}

1.1.3 Infectious Disease

Only a small group of fungi have been associated with infectious disease. Aspergillosis is an infectious disease that can occur in immunosuppressed persons. Health effects in this population can be severe. Several species of *Aspergillus* are known to cause aspergillosis. The most common is *Aspergillus fumigatus*. Exposure to this common mold, even to high concentrations, is unlikely to cause infection in a healthy person.^{11, 24}

Exposure to fungi associated with bird and bat droppings (e.g., *Histoplasma capsulatum* and *Cryptococcus neoformans*) can lead to health effects, usually transient flu-like illnesses, in healthy individuals. Severe health effects are primarily encountered in immunocompromised persons.^{24, 28, 29}

1.2 Medical Evaluation

Individuals with persistent health problems that appear to be related to fungi or other bioaerosol exposure should see their physicians for a referral to practitioners who are trained in occupational/environmental medicine or related specialties and are knowledgeable about these types of exposures. Infants (less than 12 months old) who are experiencing non-traumatic nosebleeds or are residing in dwellings with damp or moldy conditions and are experiencing breathing difficulties should receive a medical evaluation to screen for alveolar hemorrhage. Following this evaluation, infants who are suspected of having alveolar hemorrhaging should be referred to a pediatric pulmonologist. Infants diagnosed with pulmonary hemosiderosis and/or pulmonary hemorrhaging should not be returned to dwellings until remediation and air testing are completed.

Clinical tests that can determine the source, place, or time of exposure to fungi or their products are not currently available. Antibodies developed by exposed persons to fungal agents can only document that exposure has occurred. Since exposure to fungi routinely occurs in both outdoor and indoor environments this information is of limited value.

1.3 Medical Relocation

Infants (less than 12 months old), persons recovering from recent surgery, or people with immune suppression, asthma, hypersensitivity pneumonitis, severe allergies, sinusitis, or other chronic inflammatory lung diseases may be at greater risk for developing health problems associated with certain fungi. Such persons should be removed from the affected area during remediation (see Section 3, Remediation). Persons diagnosed with fungal related diseases should not be returned to the affected areas until remediation and air testing are completed.

Except in cases of widespread fungal contamination that are linked to illnesses throughout a building, a building-wide evacuation is not indicated. A trained occupational/environmental health practitioner should base decisions about medical removals in the occupational setting on the results of a clinical assessment.

top of page

2. Environmental Assessment

The presence of mold, water damage, or musty odors should be addressed immediately. In all instances, any source(s) of water must be stopped and the extent of water damaged determined. Water damaged materials should be dried and repaired. Mold damaged materials should be remediated in accordance with this document (see Section 3, Remediation).

2.1 Visual Inspection

A visual inspection is the most important initial step in identifying a possible contamination problem. The extent of any water damage and mold growth should be visually assessed. This assessment is important in determining remedial strategies. Ventilation systems should also be visually checked, particularly for damp filters but also for damp conditions elsewhere in the system and overall cleanliness. Ceiling tiles, gypsum wallboard (sheetrock), cardboard, paper, and other cellulosic surfaces should be given careful attention during a visual inspection. The use of equipment such as a boroscope, to view spaces in ductwork or behind walls, or a moisture meter, to detect moisture in building materials, may be helpful in identifying hidden sources of fungal growth and the extent of water damage.

2.2 Bulk/Surface Sampling

- a. Bulk or surface sampling is not required to undertake a remediation. Remediation (as described in Section 3, Remediation) of visually identified fungal contamination should proceed without further evaluation.
- b. Bulk or surface samples may need to be collected to identify specific fungal contaminants as part of a medical evaluation if occupants are experiencing symptoms which may be related to fungal exposure or to identify the presence or absence of mold if a visual inspection is equivocal (e.g., discoloration, and staining).
- c. An individual trained in appropriate sampling methodology should perform bulk or surface sampling. Bulk samples are usually collected from visibly moldy surfaces by scraping or cutting materials with a clean tool into a clean plastic bag. Surface samples are usually collected by wiping a measured area with a sterile swab or by stripping the suspect surface with clear tape. Surface sampling is less destructive than bulk sampling. Other sampling methods may also be available. A laboratory specializing in mycology should be consulted for specific sampling and delivery

instructions.

2.3 Air Monitoring

- a. Air sampling for fungi should not be part of a routine assessment. This is because decisions about appropriate remediation strategies can usually be made on the basis of a visual inspection. In addition, air-sampling methods for some fungi are prone to false negative results and therefore cannot be used to definitively rule out contamination.
- b. Air monitoring may be necessary if an individual(s) has been diagnosed with a disease that is or may be associated with a fungal exposure (e.g., pulmonary hemorrhage/hemosiderosis, and aspergillosis).
- c. Air monitoring may be necessary if there is evidence from a visual inspection or bulk sampling that ventilation systems may be contaminated. The purpose of such air monitoring is to assess the extent of contamination throughout a building. It is preferable to conduct sampling while ventilation systems are operating.
- d. Air monitoring may be necessary if the presence of mold is suspected (e.g., musty odors) but cannot be identified by a visual inspection or bulk sampling (e.g., mold growth behind walls). The purpose of such air monitoring is to determine the location and/or extent of contamination.
- e. If air monitoring is performed, for comparative purposes, outdoor air samples should be collected concurrently at an air intake, if possible, and at a location representative of outdoor air. For additional information on air sampling, refer to the American Conference of Governmental Industrial Hygienists' document, "Bioaerosols: Assessment and Control."
- f. Personnel conducting the sampling must be trained in proper air sampling methods for microbial contaminants. A laboratory specializing in mycology should be consulted for specific sampling and shipping instructions.

2.4 Analysis of Environmental Samples

Microscopic identification of the spores/colonies requires considerable expertise. These services are not routinely available from commercial laboratories. Documented quality control in the laboratories used for analysis of the bulk/surface and air samples is necessary. The American Industrial Hygiene Association (AIHA) offers accreditation to microbial laboratories (Environmental Microbiology Laboratory Accreditation Program (EMLAP)). Accredited laboratories must participate in quarterly proficiency testing (Environmental Microbiology Proficiency Analytical Testing Program (EMPAT)).

Evaluation of bulk/surface and air sampling data should be performed by an experienced health professional. The presence of few or trace amounts of fungal spores in bulk/surface sampling should be considered background. Amounts greater than this or the presence of fungal fragments (e.g., hyphae, and conidiophores) may suggest fungal colonization, growth, and/or accumulation at or near the sampled location.³⁰ Air samples should be evaluated by means of comparison (i.e., indoors to outdoors) and by fungal type (e.g., genera, and species). In general, the levels and types of fungi found should be similar indoors (in non-problem buildings) as compared to the outdoor air. Differences in the levels or types of fungi found in air samples may indicate that moisture sources and resultant fungal growth may be problematic.

top of page

3. Remediation

In all situations, the underlying cause of water accumulation must be rectified or fungal growth will recur. Any initial water infiltration should be stopped and cleaned immediately. An immediate response (within 24 to 48 hours) and thorough clean up, drying, and/or removal of water damaged materials will prevent or limit mold growth. If the source of water is elevated humidity, relative humidity should be maintained at levels below 60% to inhibit mold growth.³¹ Emphasis should be on ensuring proper repairs of the building infrastructure, so that water damage and moisture buildup does not recur.

Five different levels of abatement are described below. The size of the area impacted by fungal contamination primarily determines the type of remediation. The sizing levels below are based on professional judgement and practicality; currently there is not adequate data to relate the extent of contamination to frequency or severity of health effects. **The goal of remediation is to remove or clean contaminated materials in a way that prevents the emission of fungi and dust contaminated with fungi from leaving a work area and entering an occupied or non-abatement area, while protecting the health of workers performing the abatement.** The listed remediation methods were designed to achieve this goal, however, due to the general nature of these methods it is the responsibility of the people conducting remediation to ensure the methods enacted are adequate. The listed remediation methods are not meant to exclude other

similarly effective methods. Any changes to the remediation methods listed in these guidelines, however, should be carefully considered prior to implementation.

Non-porous (e.g., metals, glass, and hard plastics) and semi-porous (e.g., wood, and concrete) materials that are structurally sound and are visibly moldy can be cleaned and reused. Cleaning should be done using a detergent solution. Porous materials such as ceiling tiles and insulation, and wallboards with more than a small area of contamination should be removed and discarded. Porous materials (e.g., wallboard, and fabrics) that can be cleaned, can be reused, but should be discarded if possible. A professional restoration consultant should be contacted when restoring porous materials with more than a small area of fungal contamination. All materials to be reused should be dry and visibly free from mold. Routine inspections should be conducted to confirm the effectiveness of remediation work.

The use of gaseous, vapor-phase, or aerosolized biocides for remedial purposes is **not** recommended. The use of biocides in this manner can pose health concerns for people in occupied spaces of the building and for people returning to the treated space if used improperly. Furthermore, the effectiveness of these treatments is unproven and does not address the possible health concerns from the presence of the remaining non-viable mold. For additional information on the use of biocides for remedial purposes, refer to the American Conference of Governmental Industrial Hygienists' document, "Bioaerosols: Assessment and Control."

3.1 Level I: Small Isolated Areas (10 sq. ft or less) - e.g., ceiling tiles, small areas on walls

- a. Remediation can be conducted by regular building maintenance staff. Such persons should receive training on proper clean up methods, personal protection, and potential health hazards. This training can be performed as part of a program to comply with the requirements of the OSHA Hazard Communication Standard (29 CFR 1910.1200).
- b. Respiratory protection (e.g., N95 disposable respirator), in accordance with the OSHA respiratory protection standard (29 CFR 1910.134), is recommended. Gloves and eye protection should be worn.
- c. The work area should be unoccupied. Vacating people from spaces adjacent to the work area is not necessary but is recommended in the presence of infants (less than 12 months old), persons recovering from recent surgery, immune suppressed people, or people with chronic inflammatory lung diseases (e.g., asthma, hypersensitivity pneumonitis, and severe allergies).
- d. Containment of the work area is not necessary. Dust suppression methods, such as misting (not soaking) surfaces prior to remediation, are recommended.
- e. Contaminated materials that cannot be cleaned should be removed from the building in a sealed plastic bag. There are no special requirements for the disposal of moldy materials.
- f. The work area and areas used by remedial workers for egress should be cleaned with a damp cloth and/or mop and a detergent solution.
- g. All areas should be left dry and visibly free from contamination and debris.

3.2 Level II: Mid-Sized Isolated Areas (10 - 30 sq. ft.) - e.g., individual wallboard panels.

- a. Remediation can be conducted by regular building maintenance staff. Such persons should receive training on proper clean up methods, personal protection, and potential health hazards. This training can be performed as part of a program to comply with the requirements of the OSHA Hazard Communication Standard (29 CFR 1910.1200).
- b. Respiratory protection (e.g., N95 disposable respirator), in accordance with the OSHA respiratory protection standard (29 CFR 1910.134), is recommended. Gloves and eye protection should be worn.
- c. The work area should be unoccupied. Vacating people from spaces adjacent to the work area is not necessary but is recommended in the presence of infants (less than 12 months old), persons having undergone recent surgery, immune suppressed people, or people with chronic inflammatory lung diseases (e.g., asthma, hypersensitivity pneumonitis, and severe allergies).
- d. The work area should be covered with a plastic sheet(s) and sealed with tape before remediation, to contain dust/debris.
- e. Dust suppression methods, such as misting (not soaking) surfaces prior to remediation, are recommended.
- f. Contaminated materials that cannot be cleaned should be removed from the building in sealed plastic bags. There are no special requirements for the disposal of moldy materials.
- g. The work area and areas used by remedial workers for egress should be HEPA vacuumed (a vacuum equipped with a High-Efficiency Particulate Air filter) and cleaned with a damp cloth and/or mop and a detergent solution.
- h. All areas should be left dry and visibly free from contamination and debris.

3.3 Level III: Large Isolated Areas (30 - 100 square feet) - e.g., several wallboard panels.

A health and safety professional with experience performing microbial investigations should be consulted prior to remediation activities to provide oversight for the project.

The following procedures *at a minimum* are recommended:

- a. Personnel trained in the handling of hazardous materials and equipped with respiratory protection, (e.g., N95 disposable respirator), in accordance with the OSHA respiratory protection standard (29 CFR 1910.134), is recommended. Gloves and eye protection should be worn.
- b. The work area and areas directly adjacent should be covered with a plastic sheet(s) and taped before remediation, to contain dust/debris.
- c. Seal ventilation ducts/grills in the work area and areas directly adjacent with plastic sheeting.
- d. The work area and areas directly adjacent should be unoccupied. Further vacating of people from spaces near the work area is recommended in the presence of infants (less than 12 months old), persons having undergone recent surgery, immune suppressed people, or people with chronic inflammatory lung diseases (e.g., asthma, hypersensitivity pneumonitis, and severe allergies).
- e. Dust suppression methods, such as misting (not soaking) surfaces prior to remediation, are recommended.
- f. Contaminated materials that cannot be cleaned should be removed from the building in sealed plastic bags. There are no special requirements for the disposal of moldy materials.
- g. The work area and surrounding areas should be HEPA vacuumed and cleaned with a damp cloth and/or mop and a detergent solution.
- h. All areas should be left dry and visibly free from contamination and debris.

If abatement procedures are expected to generate a lot of dust (e.g., abrasive cleaning of contaminated surfaces, demolition of plaster walls) or the visible concentration of the fungi is heavy (blanket coverage as opposed to patchy), then it is recommended that the remediation procedures for Level IV are followed.

3.4 Level IV: Extensive Contamination (greater than 100 contiguous square feet in an area)

A health and safety professional with experience performing microbial investigations should be consulted prior to remediation activities to provide oversight for the project. The following procedures are recommended:

- a. Personnel trained in the handling of hazardous materials equipped with:
 - i. Full-face respirators with high efficiency particulate air (HEPA) cartridges
 - ii. Disposable protective clothing covering both head and shoes
 - iii. Gloves
- b. Containment of the affected area:
 - i. Complete isolation of work area from occupied spaces using plastic sheeting sealed with duct tape (including ventilation ducts/grills, fixtures, and any other openings)
 - ii. The use of an exhaust fan with a HEPA filter to generate negative pressurization
 - iii. Airlocks and decontamination room
- c. Vacating people from spaces adjacent to the work area is not necessary but is recommended in the presence of infants (less than 12 months old), persons having undergone recent surgery, immune suppressed people, or people with chronic inflammatory lung diseases (e.g., asthma, hypersensitivity pneumonitis, and severe allergies).
- d. Contaminated materials that cannot be cleaned should be removed from the building in sealed plastic bags. The outside of the bags should be cleaned with a damp cloth and a detergent solution or HEPA vacuumed in the decontamination chamber prior to their transport to uncontaminated areas of the building. There are no special requirements for the disposal of moldy materials.
- e. The contained area and decontamination room should be HEPA vacuumed and cleaned with a damp cloth and/or mop with a detergent solution and be visibly clean prior to the removal of isolation barriers.
- f. Air monitoring should be conducted prior to occupancy to determine if the area is fit to reoccupy.

3.5 Level V: Remediation of HVAC Systems

3.5.1 A Small Isolated Area of Contamination (<10 square feet) in the HVAC System

- a. Remediation can be conducted by regular building maintenance staff. Such persons should receive training on proper clean up methods, personal protection, and potential health hazards. This training can be performed as part of a

- program to comply with the requirements of the OSHA Hazard Communication Standard (29 CFR 1910.1200).
- b. Respiratory protection (e.g., N95 disposable respirator), in accordance with the OSHA respiratory protection standard (29 CFR 1910.134), is recommended. Gloves and eye protection should be worn.
 - c. The HVAC system should be shut down prior to any remedial activities.
 - d. The work area should be covered with a plastic sheet(s) and sealed with tape before remediation, to contain dust/debris.
 - e. Dust suppression methods, such as misting (not soaking) surfaces prior to remediation, are recommended.
 - f. Growth supporting materials that are contaminated, such as the paper on the insulation of interior lined ducts and filters, should be removed. Other contaminated materials that cannot be cleaned should be removed in sealed plastic bags. There are no special requirements for the disposal of moldy materials.
 - g. The work area and areas immediately surrounding the work area should be HEPA vacuumed and cleaned with a damp cloth and/or mop and a detergent solution.
 - h. All areas should be left dry and visibly free from contamination and debris.
 - i. A variety of biocides are recommended by HVAC manufacturers for use with HVAC components, such as, cooling coils and condensation pans. HVAC manufacturers should be consulted for the products they recommend for use in their systems.

3.5.2 Areas of Contamination (>10 square feet) in the HVAC System

A health and safety professional with experience performing microbial investigations should be consulted prior to remediation activities to provide oversight for remediation projects involving more than a small isolated area in an HVAC system. The following procedures are recommended:

- a. Personnel trained in the handling of hazardous materials equipped with:
 - i. Respiratory protection (e.g., N95 disposable respirator), in accordance with the OSHA respiratory protection standard (29 CFR 1910.134), is recommended.
 - ii. Gloves and eye protection
 - iii. Full-face respirators with HEPA cartridges and disposable protective clothing covering both head and shoes should be worn if contamination is greater than 30 square feet.
- b. The HVAC system should be shut down prior to any remedial activities.
- c. Containment of the affected area:
 - i. Complete isolation of work area from the other areas of the HVAC system using plastic sheeting sealed with duct tape.
 - ii. The use of an exhaust fan with a HEPA filter to generate negative pressurization.
 - iii. Airlocks and decontamination room if contamination is greater than 30 square feet.
- d. Growth supporting materials that are contaminated, such as the paper on the insulation of interior lined ducts and filters, should be removed. Other contaminated materials that cannot be cleaned should be removed in sealed plastic bags. When a decontamination chamber is present, the outside of the bags should be cleaned with a damp cloth and a detergent solution or HEPA vacuumed prior to their transport to uncontaminated areas of the building. There are no special requirements for the disposal of moldy materials.
- e. The contained area and decontamination room should be HEPA vacuumed and cleaned with a damp cloth and/or mop and a detergent solution prior to the removal of isolation barriers.
- f. All areas should be left dry and visibly free from contamination and debris.
- g. Air monitoring should be conducted prior to re-occupancy with the HVAC system in operation to determine if the area (s) served by the system are fit to reoccupy.
- h. A variety of biocides are recommended by HVAC manufacturers for use with HVAC components, such as, cooling coils and condensation pans. HVAC manufacturers should be consulted for the products they recommend for use in their systems.

top of page

4. Hazard Communication

When fungal growth requiring large-scale remediation is found, the building owner, management, and/or employer should notify occupants in the affected area(s) of its presence. Notification should include a description of the remedial measures to be taken and a timetable for completion. Group meetings held before and after remediation with full disclosure of plans and results can be an effective communication mechanism. Individuals with persistent health problems that appear to be related to bioaerosol exposure should see their physicians for a referral to practitioners who are trained in

occupational/environmental medicine or related specialties and are knowledgeable about these types of exposures. Individuals seeking medical attention should be provided with a copy of all inspection results and interpretation to give to their medical practitioners.

top of page

Conclusion

In summary, the prompt remediation of contaminated material and infrastructure repair must be the primary response to fungal contamination in buildings. The simplest and most expedient remediation that properly and safely removes fungal growth from buildings should be used. In all situations, the underlying cause of water accumulation must be rectified or the fungal growth will recur. Emphasis should be placed on preventing contamination through proper building maintenance and prompt repair of water damaged areas.

Widespread contamination poses much larger problems that must be addressed on a case-by-case basis in consultation with a health and safety specialist. Effective communication with building occupants is an essential component of all remedial efforts. Individuals with persistent health problems should see their physicians for a referral to practitioners who are trained in occupational/environmental medicine or related specialties and are knowledgeable about these types of exposures.

top of page

Notes and References

1. Bata A, Harrach B, Kalman U, Kis-tamas A, Lasztity R. Macrocytic Trichothecene Toxins Produced by *Stachybotrys atra* Strains Isolated in Middle Europe. *Applied and Environmental Microbiology* 1985; **49**:678-81.
2. Jarvis B, "Mycotoxins and Indoor Air Quality," *Biological Contaminants in Indoor Environments, ASTM STP 1071*, Morey P, Feely Sr. J, Otten J, Editors, American Society for Testing and Materials, Philadelphia, 1990.
3. Yang C, Johanning E, "Airborne Fungi and Mycotoxins," *Manual of Environmental Microbiology*, Hurst C, Editor in Chief, ASM Press, Washington, D.C., 1996
4. Jarvis B, Mazzola E. Macrocytic and Other Novel Trichothecenes: Their Structure, Synthesis, and Biological Significance. *Acc. Chem. Res.* 1982; **15**:388-95.
5. Von Essen S, Robbins R, Thompson A, Rennard S. Organic Dust Toxic Syndrome: An Acute Febrile Reaction to Organic Dust Exposure Distinct from Hypersensitivity Pneumonitis. *Clinical Toxicology* 1990; **28(4)**:389-420.
6. Richerson H. Unifying Concepts Underlying the Effects of Organic Dust Exposures. *American Journal of Industrial Medicine* 1990; **17**:139-42.
7. Malmberg P, Rask-Andersen A, Lundholm M, Palmgren U. Can Spores from Molds and Actinomycetes Cause an Organic Dust Toxic Syndrome Reaction?. *American Journal of Industrial Medicine* 1990; **17**:109-10.
8. Malmberg P. Health Effects of Organic Dust Exposure in Dairy Farmers. *American Journal of Industrial Medicine* 1990; **17**:7-15.
9. Yoshida K, Masayuki A, Shukuro A. Acute Pulmonary Edema in a Storehouse of Moldy Oranges: A Severe Case of the Organic Dust Toxic Syndrome. *Archives of Environmental Health* 1989; **44(6)**: 382-84.
10. Lecours R, Laviolette M, Cormier Y. Bronchoalveolar Lavage in Pulmonary Mycotoxicosis. *Thorax* 1986; **41**:924-6.
11. Levetin E. "Fungi," *Bioaerosols*, Burge H, Editor, CRC Press, Boca Raton, Florida, 1995.
12. Husman T. Health Effects of Indoor-air Microorganisms. *Scand J Work Environ Health* 1996; **22**:5-13.
13. Miller J D. Fungi and Mycotoxins in Grain: Implications for Stored Product Research. *J Stored Prod Res* 1995; **31(1)**:1-16.
14. Cookingham C, Solomon W. "Bioaerosol-Induced Hypersensitivity Diseases," *Bioaerosols*, Burge H, Editor, CRC Press, Boca Raton, Florida, 1995.
15. Rautiala S, Reponen T, Nevalainen A, Husman T, Kallioikoski P. Control of Exposure to Airborne Viable Microorganisms During Remediation of Moldy Buildings; Report of Three Case Studies. *American Industrial Hygiene Association Journal* 1998; **59**:455-60.
16. Dales R, Zwanenburg H, Burnett R, Franklin C. Respiratory Health Effects of Home Dampness and Molds among Canadian Children. *American Journal of Epidemiology* 1991; **134(2)**: 196-203.
17. Hodgson M, Morey P, Leung W, Morrow L, Miller J D, Jarvis B, Robbins H, Halsey J, Storey E. Building-Associated Pulmonary Disease from Exposure to *Stachybotrys chartarum* and *Aspergillus versicolor*. *Journal of Occupational and Environmental Medicine* 1998; **40(3)**:241-9.
18. Croft W, Jarvis B, Yatawara C. Airborne Outbreak of Trichothecene Toxicosis. *Atmospheric Environment* 1986; **20(3)** 549-52.

19. DeKoster J, Thorne P. Bioaerosol Concentrations in Noncomplaint, Complaint, and Intervention Homes in the Midwest. *American Industrial Hygiene Association Journal* 1995; **56**:573-80.
20. Johanning E, Biagini R, Hull D, Morey P, Jarvis B, Landbergis P. Health and Immunological Study Following Exposure to Toxicogenic Fungi (*Stachybotrys chartarum*) in a Water-Damaged Office Environment. *Int Arch Occup Environ Health* 1996; **68**:207-18.
21. Montana E, Etzel R, Allan T, Horgan T, Dearborn D. Environmental Risk Factor Associated with Pediatric Idiopathic Pulmonary Hemorrhage and Hemosiderosis in a Cleveland Community. *Pediatrics* 1997; **99**(1)
22. Etzel R, Montana E, Sorenson W G, Kullman G, Allan T, Dearborn D. Acute Pulmonary Hemorrhage in Infants Associated with Exposure to *Stachybotrys atra* and Other Fungi. *Ach Pediatr Adolesc Med* 1998; **152**:757-62.
23. CDC. Update: Pulmonary Hemorrhage/Hemosiderosis Among Infants --- Cleveland, Ohio, 1993 - 1996. *MMWR* 2000; **49**(9): 180-4.
24. Burge H, Otten J. "Fungi," *Bioaerosols Assessment and Control*, Macher J, Editor, American Conference of Industrial Hygienists, Cincinnati, Ohio, 1999.
25. do Pico G. Hazardous Exposure and Lung Disease Among Farm Workers. *Clinics in Chest Medicine* 1992; **13**(2):311-28.
26. Hodgson M, Morey P, Attfield M, Sorenson W, Fink J, Rhodes W, Visvesvara G. Pulmonary Disease Associated with Cafeteria Flooding. *Archives of Environmental Health* 1985; **40**(2):96-101.
27. Weltermann B, Hodgson M, Storey E, DeGraff, Jr. A, Bracker A, Groseclose S, Cole S, Cartter M, Phillips D. Hypersensitivity Pneumonitis: A Sentinel Event Investigation in a Wet Building. *American Journal of Industrial Medicine* 1998; **34**:499-505.
28. Band J. "Histoplasmosis," *Occupational Respiratory Diseases*, Merchant J, Editor, U.S. Department of Health and Human Services, Washington D.C., 1986.
29. Bertolini R. "Histoplasmosis A Summary of the Occupational Health Concern," Canadian Centre for Occupational Health and Safety. Hamilton, Ontario, Canada, 1988.
30. Yang C. P&K Microbiology Services, Inc. Microscopic Examination of Sticky Tape or Bulk Samples for the Evaluation and Identification of Fungi. Cherry Hill, New Jersey.
31. American Society of Heating, Refrigerating and Air-Conditioning Engineers, Inc. Thermal Environmental Conditions for Human Occupancy - ASHRAE Standard (ANSI/ASHRAE 55-1992). Atlanta, Georgia, 1992.

top of page

Acknowledgments

The New York City Department of Health would like to thank the following individuals and organizations for participating in the revision of these guidelines. Please note that these guidelines do not necessarily reflect the opinions of the participants nor their organizations.

| Name | Company/Institution |
|----------------------|---|
| Dr. Susan Klitzman | Hunter College |
| Dr. Philip Morey | AQS Services, Inc |
| Dr. Donald Ahearn | Georgia State University |
| Dr. Sidney Crow | Georgia State University |
| Dr. J. David Miller | Carleton University |
| Dr. Bruce Jarvis | University of Maryland at College Park |
| Mr. Ed Light | Building Dynamics, LLC |
| Dr. Chin Yang | P&K Microbiology Services, Inc |
| Dr. Harriet Burge | Harvard School of Public Health |
| Dr. Dorr Dearborn | Rainbow Children's Hospital |
| Mr. Eric Esswein | National Institute for Occupational Safety and Health |
| Dr. Ed Horn | The New York State Department of Health |
| Dr. Judith Schreiber | The New York State Department of Health |
| Mr. Gregg Recer | The New York State Department of Health |
| Dr. Gerald Llewellyn | State of Delaware, Division of Public Health |
| Mr. Daniel Price | Interface Research Corporation |

| | |
|--------------------------|---|
| Ms. Sylvia Pryce | The NYC Citywide Office of Occupational Safety and Health |
| Mr. Armando Chamorro | Ambient Environmental |
| Ms. Marie-Alix d'Halewyn | Laboratoire de santé publique du Québec |
| Dr. Elissa A. Favata | Environmental and Occupational Health Associates |
| Dr. Harriet Ammann | Washington State Department of Health |
| Mr. Terry Allan | Cuyahoga County Board of Health |

We would also like to thank the many others who offered opinions, comments, and assistance at various stages during the development of these guidelines.

Christopher D'Andrea, M.S. of the Environmental and Occupational Disease Epidemiology Unit, was the editor of this document.

For further information regarding this document please contact the New York City Department of Health at 311.

[Go Back to DOHMH Page](#)

Mold Remediation Project Clearance Protocol

PREPARED FOR:

FEDERAL AVIATION ADMINISTRATION

**Detroit Metropolitan Wayne County
Airport Traffic Control Tower
(DTW ATCT)**

DETROIT, MICHIGAN

June 13, 2008



PREPARED BY:

Barbara Hebert, CIH
NISC, KANSAS CITY ARTCC DISTRICT TSU

The **DTW ATCT Mold Remediation and Restoration Project** will include the removal of moisture and microbiological-contaminated gypsum board, shaft liner, and insulation.

After Rooms 928 and 428 have passed a thorough visual inspection, and before the outer containment barrier is removed, clearance air sampling will be performed.

Five consecutive samples will be collected inside the containment area using a high volume air sampler and Zefon Air-O-Cell® cassettes. Sampling will be conducted at a flow rate of 15 liters per minute for a period of five minutes each, resulting in a collection volume of 75 liters of air. Environmental conditions may warrant the sample collection period to be reduced to one-minute intervals, in order to reduce the collection of non-microbial particulates that can mask the presence of mold spores.

Three consecutive samples will be collected outside the containment area, but inside the ATCT in a noncomplaint area, in the same manner as above. Sampling will be conducted at a flow rate of 15 liters per minute for a period of five minutes each, resulting in a collection volume of 75 liters of air.

Three consecutive samples will be collected outside of the building, in the same manner as above. Sampling will be conducted at a flow rate of 15 liters per minute for a period of 10 minutes each, resulting in a collection volume of 150 liters of air.

For all samples collected, the high volume air sampler will be calibrated before and after use.

All samples, one lab blank, and a completed Chain of Custody form will be sent to Aerotech Laboratories, Inc., by Federal Express Priority Overnight delivery. The samples will be mailed in a rigid container or box. There is no additional temperature handling requirement.

All samples will be clearly labeled. The sample identification number appearing on the cassette **must** match the identification number shown on the Chain of Custody form. The samples will be analyzed in accordance with **Aerotech Method A001** (equivalent to the cassette manufacturer's recommended analytical procedure) via light microscopy at 600X magnification, with the entire slide (100% of the sample) being analyzed. The results will be reported as a total fungal spore count, in counts per cubic meter (counts/M³), which includes both viable and non-viable spores.

The area will be considered "clean" when the average airborne total mold spore concentration measured inside the containment area was not statistically higher than the average airborne concentration measured outside the containment area, **and** the **genus level** constituents similar for **all samples taken inside the containment, inside the building (but outside of the containment) and outside of the building.**

Statistical significance may be determined in the following manner:

A. All containment sample airborne total concentration levels are lower than those taken from outside the containment, or

B. The Z-test score is less than or equal to 1.65 Standard Deviations from the Mean, indicating a 90% confidence interval. The Z-test is carried out by calculating:

$$Z = \frac{Y_I - Y_O}{0.8 (1/n_I + 1/n_O)^{1/2}}$$

where Y_I is the average of the natural logarithms of the inside samples, Y_O is the average of the natural logarithms of the outside samples, n_I is the number of inside samples and n_O is the number of outside samples.

Alternative A shall be considered first, then if necessary, Alternative B. Should the calculated Z-test score exceed 1.65, the abatement area must be recleaned. An additional set of 10 samples must then be collected, as defined above, in order to establish clearance.

The genus level constituents will be evaluated using the Spearman Rank Order Correlation (SROC), which is a statistical technique used to test the direction and strength of the relationship between two variables. It uses the statistic "Rs", which falls between -1 and +1. If the "Rs" value is -1, there is a perfect negative correlation; between -1 and -0.5, there is a strong negative correlation; between -0.5 and 0, there is a weak negative correlation; if 0, there is no correlation; between 0 and 0.5, there is a weak positive correlation; between 0.5 and 1, there is a strong positive correlation; and if 1, there is a perfect positive correlation. Calculated "Rs" values will also be compared to the Critical Values (CV) listed in Table 13.7 of the American Conference of Governmental Industrial Hygienists "Bioaerosols: Assessment and Control", which are drawn from a standard statistical table. Comparing the "Rs" value to the CV permits a methodical acceptance or rejection. If the "Rs" value exceeds the 0.1 confidence level, the populations appear to be related or similar. If the "Rs" value is below the 0.1 confidence level, the populations do not appear to be related or are different. Should the "Rs" value be below the 0.1 confidence level, the remediation area must be recleaned unless a professional opinion can justify rank differences to be insignificant.

Once the abatement area has passed the clearance criteria, the outer containment barrier will be removed and the room will be available for restoration.

Visual inspections and clearance air sampling will be performed upon completion of the mold remediation, but prior to the re-installation of new building materials.

The visual inspection, clearance air sampling, and data interpretation will be conducted by the government-retained Industrial Hygienist.

SCOPE OF WORK

FLOOR 3:

1. PRIOR TO PERFORMING MICROBIOLOGICAL REMEDIATION PROCEDURES THE CONTRACTOR SHALL SEAL ALL CRITICAL PENETRATIONS AND CONTIGUOUS TO THE WORK AREA WITH A MINIMUM OF TWO LAYERS OF 6-MIL POLYETHYLENE AND SHALL BE RESPONSIBLE FOR ENSURING ADJACENT AREAS ARE NOT EXPOSED TO THE MICROBIOLOGICAL CONTAMINATION DURING THE REMEDIATION.
2. REMOVE ANY MCM BETWEEN THE BOTTOM METAL RUNNER/TRACK AND THE CONCRETE FLOOR, BETWEEN THE TOP METAL RUNNER/TRACK AND THE STRUCTURAL DECK AND BETWEEN THE METAL STUD AND EXTERIOR CONCRETE WALL.
3. THE CONTRACTOR SHALL MINIMIZE DUST GENERATION AND USE THE METHODOLOGES OUTLINED IN GARFIE FOR DUST PREVENTION AND SUPPRESSION.
4. ALL REMOVALS AND OTHER CLEANING PROCEDURES SHALL BE CONDUCTED AT NIGHT BETWEEN THE HOURS OF 1000 PM AND 6:00 AM. NEGATIVE AIR PRESSURE EQUIPMENT SHALL BE EQUIPPED WITH A HEPA FILTER AND DISCHARGED OUTSIDE OF THE BUILDING WHENEVER POSSIBLE, OTHERWISE DISCHARGED THROUGH A SECOND HEPA FILTER IN ORDER TO PERMIT RECIRCULATION OF AIR INSIDE THE BUILDING.

ROOM 327

1. THE CONTRACTOR SHALL PROVIDE ADDITIONAL CLEANING PROCEDURES AND PIPE INSULATION REMOVAL/REPLACEMENT.
2. APPROXIMATELY 15 LINEAR FEET OF 1/2" WATER STAINED AND/OR CONTAMINATED CHILLED AND HEATING WATER PIPE INSULATION SHALL BE REMOVED AND REPLACED.

ROOM 328

1. A MHC CONTAINMENT SHALL BE ESTABLISHED CONSISTING OF A SINGLE LAYER OF 6-MIL POLYETHYLENE SHEETING. A NEGATIVE PRESSURE ENCLOSURE SYSTEM SHALL BE ESTABLISHED AS DESCRIBED IN SECTION 18.10 REMEDIATION AREA.
2. THE EAST (ELEVATOR SHAFT) WALL UP TO A HEIGHT OF 2' AND THE SOUTH (ELEVATOR SHAFT) WALL UP TO A HEIGHT OF 2' SHALL BE HEPA VACUUMED AND THEN WET WIPED WITH AN APPROVED CLEANING SOLUTION.

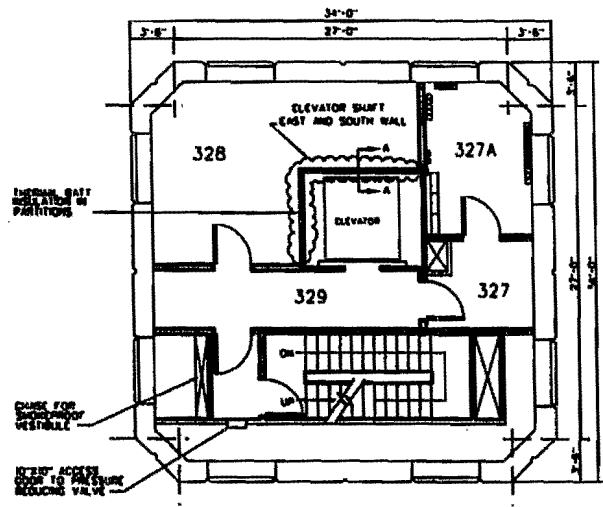

THIRD FLOOR SHAFT PLAN

SCALE: 1/4" = 1'-0"
SCALE IN FEET

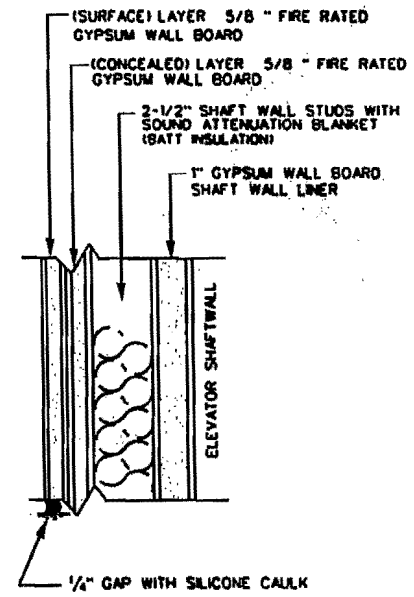

DETAIL A - PARTITION WALL
(2 HOUR FIRE RATING)

NOT TO SCALE

| | | |
|--|--------------|----------------|
| DEPARTMENT OF TRANSPORTATION FEDERAL AVIATION ADMINISTRATION | | DATE: 07/15/08 |
| MOISTURE DAMAGE REMEDIATION 3RD FLOOR ATCT DETROIT METRO WAREHOUSE AIRPORT DETROIT, MICHIGAN | | |
| PROJECT NO. 07-01-00000000 | ISSUE NO. 02 | DATE 07/15/08 |
| PROJECT: 3RD FL. MOISTURE DAMAGE | ISSUE: 02 | DATE: 07/15/08 |
| PROJECT NO. 07-01-00000000 | ISSUE NO. 02 | DATE 07/15/08 |

SCOPE OF WORK

FLOOR 4:

1. PRIOR TO PERFORMING MICROBIOLOGICAL REMEDIATION PROCEDURES, THE CONTRACTOR SHALL SEAL ALL CRITICAL PENETRATIONS AND OPENINGS TO THE WORK AREA WITH A MINIMUM OF TWO LAYERS OF 6-MIL POLYETHYLENE, AND SHALL BE RESPONSIBLE FOR EXHAUSTING ROOMS AREAS NOT EXPOSED TO THE MICROBIOLOGICAL CONTAMINATION DURING THE REMEDIATION.

2. REMOVE ANY MSA BETWEEN THE BOTTOM METAL RUNNER/TRACK AND THE CONCRETE FLOOR BETWEEN THE TOP METAL RUNNER/TRACK AND THE STRUCTURAL BEAM AND BETWEEN THE METAL STUD AND EXTERIOR CONCRETE WALL.

3. THE CONTRACTOR SHALL MINIMIZE DUST GENERATION AND USE THE METHODOLOGIES OUTLINED IN CARP FOR DUST PREVENTION AND SUPPRESSION.

4. ALL REMOVALS AND OTHER CLEANING PROCEDURES SHALL BE CONDUCTED AT NIGHT BETWEEN THE HOURS OF 7:00 PM AND 6:00 AM. NEGATIVE AIR PRESSURE EQUIPMENT SHALL BE EQUIPPED WITH A HEPA FILTER AND DISCHARGED OUTSIDE OF THE BUILDING WHENEVER POSSIBLE, OTHERWISE DISCHARGED THROUGH A SECOND HEPA FILTER IN ORDER TO PERMIT RECIRCULATION OF AIR INSIDE THE BUILDING.

ROOM 427:

1. THE CONTRACTOR SHALL PROVIDE ADDITIONAL CLEANING PROCEDURES AND PIPE INSULATION REMOVAL/REPLACEMENT.

2. APPROXIMATELY 4 LINEAR FEET OF 1" AND 6 LINEAR FEET OF 1/2" WATER STAINED AND/OR CONTAMINATED CHILLED AND HEATING WATER PIPE INSULATION SHALL BE REMOVED AND REPLACED.

ROOM 428:

1. A CONTAMINANT AND NEGATIVE PRESSURE ENCLOSURE SYSTEM SHALL BE ESTABLISHED AS DESCRIBED IN SECTION 18.10 REMEDIATION AREA. A DECONTAMINATION UNIT SHALL BE ESTABLISHED AS DESCRIBED IN SECTION 18.11 DECONTAMINATION.

2. CLEANUP AND REMOVAL OF MOISTURE AND MICROBIOLOGICAL CONTAMINATED GYPSUM BOARD, SHAFT LINER, AND INSULATION IN THE OTW ATCT ROOM 428 IN ACCORDANCE WITH THE GUIDELINES ESTABLISHED BY THE NEW YORK CITY DEPARTMENT OF HEALTH ENTITLED GUIDELINES ON ASSESSMENT AND REMEDIATION OF FUNGI IN INDOOR ENVIRONMENTS (CARP) (SEE SPECIFICATION ATTACHMENT 1).

3. REMOVE GYPSUM BOARD, SHAFT LINER, AND INSULATION TOTALING APPROXIMATELY 343 SQUARE FEET.

A. THE EAST ELEVATOR SHAFT WALL, 8" WIDE TO A HEIGHT OF 5' (SURFACE LAYER), 8" WIDE TO A HEIGHT OF 4'6" (CONCEALED LAYER), AND 8" WIDE TO A HEIGHT OF 4' (SHAFT LINER).

B. THE SOUTH ELEVATOR SHAFT WALL, 10" WIDE TO A HEIGHT OF 5' (SURFACE LAYER), 10" WIDE TO A HEIGHT OF 4'6" (CONCEALED LAYER), AND 10" WIDE TO A HEIGHT OF 4' (SHAFT LINER).

C. ELEVATOR SHAFT LINER REMOVAL AND REPLACEMENT REQUIRES COORDINATION WITH THE ELEVATOR MAINTENANCE CO. AND AIR TRAFFIC TO SCHEDULE LIMITED ELEVATOR SHUTDOWN TIME.

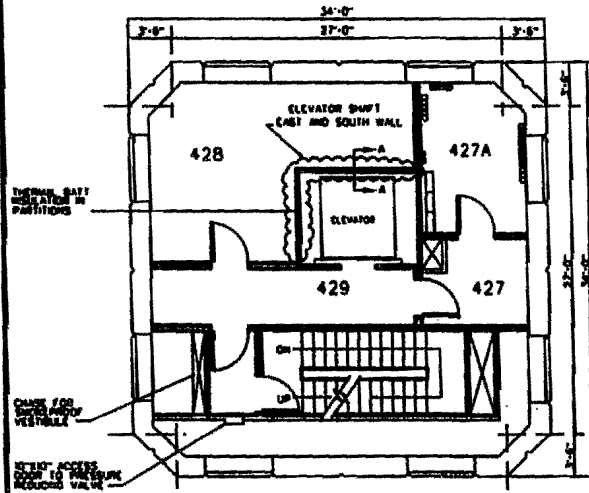

FOURTH FLOOR SHAFT PLAN

SCALE: 1/4" = 1'-0"
SCALE IN FEET

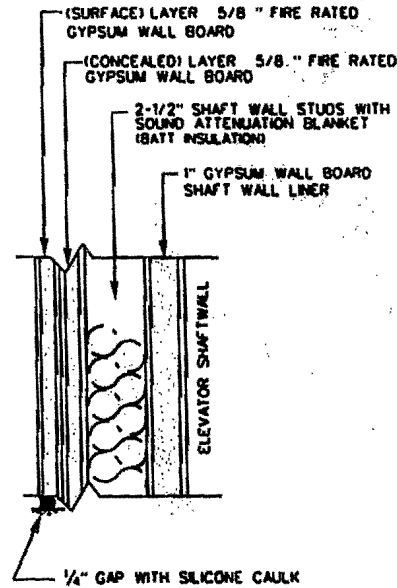

DETAIL A - PARTITION WALL
(2 HOUR FIRE RATING)

NOT TO SCALE

| | | |
|---|------|----------------|
| DEPARTMENT OF TRANSPORTATION FEDERAL AVIATION ADMINISTRATION | | PROJECT NUMBER |
| MOISTURE DAMAGE REMEDIATION 4TH FLOOR ATCT DETROIT METRO WAYNE COUNTY AIRPORT DETROIT, MICHIGAN | | DATE |
| APPROVED | DATE | BY |
| DESIGNED | DATE | BY |
| CHECKED | DATE | BY |
| PROJECT MANAGER | DATE | BY |
| PROJECT SUPERVISOR | DATE | BY |
| PROJECT ENGINEER | DATE | BY |
| PROJECT ARCHITECT | DATE | BY |

| | | | |
|-----|-------------------------|------|----|
| NO. | DESCRIPTION | DATE | BY |
| 1 | ISSUED FOR PERMITTING | | |
| 2 | ISSUED FOR CONSTRUCTION | | |
| 3 | ISSUED FOR AS-BUILT | | |
| 4 | ISSUED FOR RECORD | | |
| 5 | ISSUED FOR ARCHIVE | | |

SCOPE OF WORK

FLOOR 5

1. PRIOR TO PERFORMING MICROBIOLOGICAL REMEDIATION PROCEDURES, THE CONTRACTOR SHALL SEAL ALL CRITICAL PENETRATIONS AND OPENINGS TO THE WORK AREA WITH A MINIMUM OF TWO LAYERS OF 6-MIL POLYETHYLENE, AND SHALL BE RESPONSIBLE FOR ENSURING ALLOWING AREAS ARE NOT EXPOSED TO THE MICROBIOLOGICAL CONTAMINATION DURING THE REMEDIATION.

2. REMOVE ANY MOISTURE BETWEEN THE BOTTOM METAL RUNNER/TRACK AND THE CONCRETE FLOOR BETWEEN THE TOP METAL RUNNER/TRACK AND THE STRUCTURAL DECK AND BETWEEN THE METAL STUD AND EXTERIOR CONCRETE WALL.

3. THE CONTRACTOR SHALL MINIMIZE DUST GENERATION AND USE THE METHODOLOGIES OUTLINED IN CHARTER FOR DUST PREVENTION AND SUPPRESSION.

4. ALL REMOVALS AND OTHER CLEANING PROCEDURES SHALL BE CONDUCTED AT NIGHT BETWEEN THE HOURS OF 10:00 PM AND 6:00 AM. NEGATIVE AIR PRESSURE EQUIPMENT SHALL BE EQUIPPED WITH A HEPA FILTER AND DISCHARGED OUTSIDE OF THE BUILDING WHENEVER POSSIBLE. OTHERWISE DISCHARGED THROUGH A SECOND HEPA FILTER IN ORDER TO PERMIT RECIRCULATION OF AIR INSIDE THE BUILDING.

ROOM 527

1. A CONTAINMENT AND NEGATIVE PRESSURE ENCLOSURE SYSTEM SHALL BE ESTABLISHED AS DESCRIBED IN SECTION 18.0 DECONTAMINATION. A DECONTAMINATION UNIT SHALL BE ESTABLISHED AS DESCRIBED IN SECTION 18.0 DECONTAMINATION.

2. CLEANUP AND REMOVAL OF MOISTURE AND MICROBIOLOGICAL CONTAMINATED GYPSUM BOARD, SHAFT LINER AND INSULATION IN ACCORDANCE WITH THE GUIDELINES ESTABLISHED BY THE NEW YORK CITY DEPARTMENT OF HEALTH ENTITLED GUIDELINES ON ASSESSMENT AND REMEDIATION OF FUNGUS IN DOOR ENVIRONMENTS (GARTE) (SEE SPECIFICATION ATTACHMENT II).

3. APPROXIMATELY A LINEAR FEET OF 1" AND 25 LINEAR FEET OF 1/2" WATER STAINED AND/OR CONTAMINATED COOLED AND HEATING WATER PIPE INSULATION SHALL BE REMOVED AND REPLACED.

4. REMOVE GYPSUM BOARD AND INSULATION TOTALING APPROXIMATELY 15 SQUARE FEET, 2" WIDE TO A HEIGHT OF 4" SURFACE LAYER AND 2" WIDE TO A HEIGHT OF 3/4" CONCEALED LAYER.

ROOM 527A

1. A CONTAINMENT AND NEGATIVE PRESSURE ENCLOSURE SYSTEM SHALL BE ESTABLISHED AS DESCRIBED IN SECTION 18.0 DECONTAMINATION. A DECONTAMINATION UNIT SHALL BE ESTABLISHED AS DESCRIBED IN SECTION 18.0 DECONTAMINATION.

2. CLEANUP AND REMOVAL OF MOISTURE AND MICROBIOLOGICAL CONTAMINATED GYPSUM BOARD, SHAFT LINER AND INSULATION IN ACCORDANCE WITH THE GUIDELINES ESTABLISHED BY THE NEW YORK CITY DEPARTMENT OF HEALTH ENTITLED GUIDELINES ON ASSESSMENT AND REMEDIATION OF FUNGUS IN DOOR ENVIRONMENTS (GARTE) (SEE SPEC. ATTACHMENT II).

3. REMOVE GYPSUM BOARD AND INSULATION TOTALING APPROXIMATELY 15 SQUARE FEET FROM THE PORTION OF THE NORTH WALL BETWEEN THE EAST WALL AND THE DOOR TO ROOM 527A, 2" WIDE TO A HEIGHT OF 4" SURFACE LAYER AND 2" WIDE TO A HEIGHT OF 3/4" CONCEALED LAYER.

ROOM 529

1. A MINICONTAINMENT SHALL BE ESTABLISHED CONSISTING OF A SINGLE LAYER OF 6-MIL POLYETHYLENE SHEETING BUT A NEGATIVE PRESSURE ENCLOSURE SYSTEM IS NOT REQUIRED. NET ANY CONTAMINATED AREAS PRIOR TO REMOVAL. UPON COMPLETION, THE WORK AREA SHALL BE HEPA VACUATED AND THEN WET WIPED WITH A DECONTAM SOLUTION.

2. THE PORTION OF THE EAST WALL BETWEEN THE SOUTH WALL AND STAIRWELL DOORFRAME, 2" WIDE TO A HEIGHT OF 8", SHALL BE HEPA VACUATED AND THEN WET WIPED WITH AN APPROVED CLEANING SOLUTION.

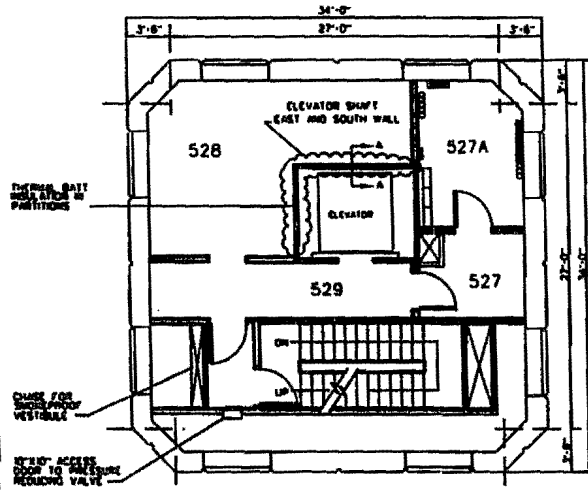

FIFTH FLOOR SHAFT PLAN

SCALE: 1/4" = 1'-0"
SCALE IN FEET

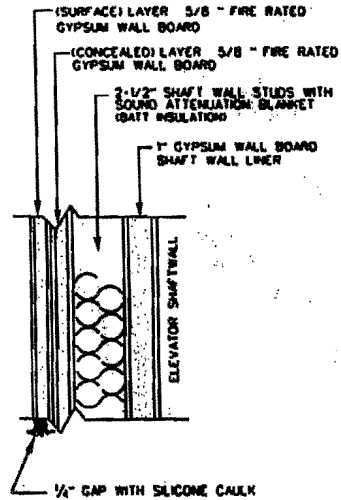

DETAIL A - PARTITION WALL

12 HOUR FIRE RATED
NOT TO SCALE

| | |
|---|----------------------------|
| DEPARTMENT OF TRANSPORTATION FEDERAL AVIATION ADMINISTRATION | |
| PROJECT NUMBER: 0304000000 | DRAWING NUMBER: 0304000000 |
| MOISTURE DAMAGE REMEDIATION | |
| 5TH FLOOR | |
| ATCT | |
| DETROIT METRO WAYNE COUNTY AIRPORT | |
| DETROIT, MICHIGAN | |
| DATE: 07/15/2008 | BY: [Signature] |
| SCALE: 1/4" = 1'-0" | PROJECT: 0304000000 |

SCOPE OF WORK

FLOOR 6

1. PRIOR TO PERFORMING MICROBIOLOGICAL REMEDIATION PROCEDURES, THE CONTRACTOR SHALL SEAL ALL CRITICAL PENETRATIONS AND OPENINGS TO THE WORK AREA WITH A MINIMUM OF TWO LAYERS OF 6-MIL POLYETHYLENE, AND SHALL BE RESPONSIBLE FOR ENSURING ADJOINING AREAS ARE NOT EXPOSED TO THE MICROBIOLOGICAL CONTAMINATION DURING THE REMEDIATION.

2. REMOVE ANY MCM BETWEEN THE BOTTOM METAL RUNNER/TRACK AND THE CONCRETE FLOOR BETWEEN THE TOP METAL RUNNER/TRACK AND THE STRUCTURAL DECK AND BETWEEN THE METAL STUD AND EXTERIOR CONCRETE WALL.

3. THE CONTRACTOR SHALL MINIMIZE DUST GENERATION AND USE THE METHODOLOGIES OUTLINED IN GAFPE FOR DUST PREVENTION AND SUPPRESSION.

4. ALL REMOVALS AND OTHER CLEANING PROCEDURES SHALL BE CONDUCTED AT NIGHT BETWEEN THE HOURS OF 11:00 PM AND 6:00 AM. NEGATIVE AIR PRESSURE EQUIPMENT SHALL BE EQUIPPED WITH A HEPA FILTER AND DISCHARGED OUTSIDE OF THE BUILDING WHENEVER POSSIBLE, OTHERWISE DISCHARGED THROUGH A SECOND HEPA FILTER IN ORDER TO PERMIT RECIRCULATION OF AIR INSIDE THE BUILDING.

ROOM 627

1. THE CONTRACTOR SHALL PROVIDE ADDITIONAL CLEANING PROCEDURES AND PIPE INSULATION REMOVAL/REPLACEMENT.

2. APPROXIMATELY 20 LINEAR FEET OF 1" AND 25 LINEAR FEET OF 1/2" WATER STANDED AND/OR CONTAMINATED CHILLED AND HEATING WATER PIPE INSULATION SHALL BE REMOVED AND REPLACED.

ROOM 628

1. A MINICONTAINMENT SHALL BE ESTABLISHED CONSISTING OF A SINGLE LAYER OF 6-MIL POLYETHYLENE SHEETING. A NEGATIVE PRESSURE ENCLOSURE SYSTEM SHALL BE ESTABLISHED AS DESCRIBED IN SECTION 16.10 REMEDIATION AREA.

2. THE EAST (ELEVATOR SHAFT) WALL, UP TO A HEIGHT OF 4', SHALL BE HEPA VACUUMED AND THEN WET WIPED WITH AN APPROVED CLEANING SOLUTION.

3. THE SOUTH ELEVATOR SHAFT WALL, UP TO A HEIGHT OF 4', SHALL BE HEPA VACUUMED AND THEN WET WIPED WITH AN APPROVED CLEANING SOLUTION.

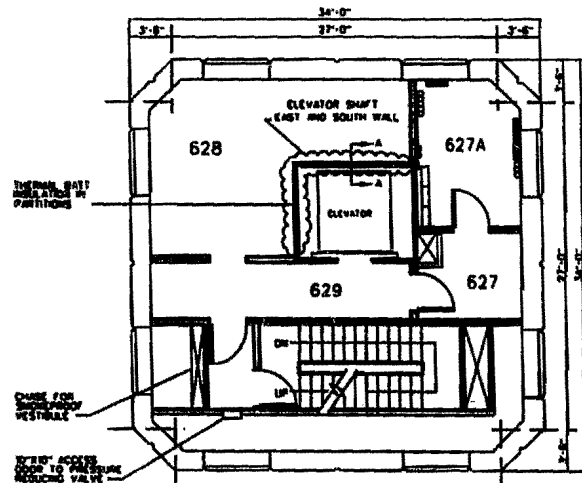

SIXTH FLOOR SHAFT PLAN

SCALE: 1/8" = 1'-0"
SCALE IN FEET

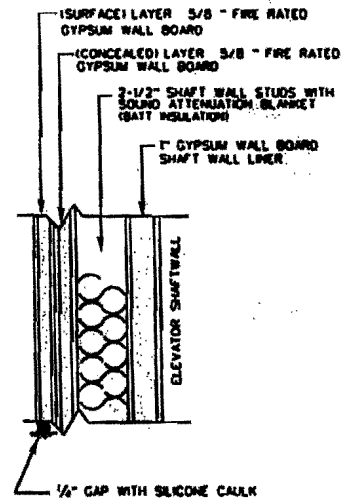

DETAIL A - PARTITION WALL

(2 HOUR FIRE RATING)
NOT TO SCALE

| | | | |
|---|----------------------------|------------------------|---------------------|
| DEPARTMENT OF ENVIRONMENTAL FEDERAL AVIATION ADMINISTRATION | | DATE: 07/15/08 | SCALE: 1/8" = 1'-0" |
| PROJECT: MOISTURE DAMAGE REMEDIATION 6TH FLOOR ATCT | | DRAWN BY: [REDACTED] | |
| LOCATION: DETROIT METRO WAYNE COUNTY AIRPORT DETROIT, MICHIGAN | | CHECKED BY: [REDACTED] | |
| NO. | DESCRIPTION | DATE | BY |
| 01 | ISSUED FOR PERMIT | 07/15/08 | [REDACTED] |
| 02 | ISSUED FOR MOISTURE DAMAGE | 07/15/08 | [REDACTED] |
| 03 | ISSUED FOR [REDACTED] | 07/15/08 | [REDACTED] |

SCOPE OF WORK

FLOOR 7:

1. PRIOR TO PERFORMING MICROBIOLOGICAL REMEDIATION PROCEDURES, THE CONTRACTOR SHALL SEAL ALL CRITICAL PENETRATIONS AND OPENINGS TO THE WORK AREA WITH A MINIMUM OF TWO LAYERS OF 6-MIL POLYETHYLENE, AND SHALL BE RESPONSIBLE FOR ENSURING ADJACENT AREAS ARE NOT EXPOSED TO THE MICROBIOLOGICAL CONTAMINATION DURING THE REMEDIATION.

2. REMOVE ANY MCM BETWEEN THE BOTTOM METAL RUBBER/TRACK AND THE CONCRETE FLOOR BETWEEN THE TOP METAL RUBBER/TRACK AND THE STRUCTURE, OCCUR AND BETWEEN THE METAL STUD AND EXTERIOR CONCRETE WALL.

3. THE CONTRACTOR SHALL MINIMIZE DUST GENERATION AND USE THE METHODOLOGIES OUTLINED IN GAWF FOR DUST PREVENTION AND SUPPRESSION.

4. ALL REMOVALS AND OTHER CLEANING PROCEDURES SHALL BE CONDUCTED AT NIGHT BETWEEN THE HOURS OF 11:00 PM AND 5:00 AM. NEGATIVE AIR PRESSURE EQUIPMENT SHALL BE EQUIPPED WITH A HEPA FILTER AND DISCHARGED OUTSIDE OF THE BUILDING WHENEVER POSSIBLE, OTHERWISE DISCHARGED THROUGH A SECOND HEPA FILTER IN ORDER TO PERMIT RECIRCULATION OF AIR INSIDE THE BUILDING.

ROOM 727

1. THE CONTRACTOR SHALL PROVIDE ADDITIONAL CLEANING PROCEDURES AND PIPE INSULATION REMOVAL/REPLACEMENT.

2. APPROXIMATELY 3 LINEAR FEET OF 1" WATER STAINED AND/OR CONTAMINATED CHILLED AND HEATING WATER PIPE INSULATION SHALL BE REMOVED AND REPLACED.

ROOM 727A

1. A MISCONTAINMENT SHALL BE ESTABLISHED CONSISTING OF A SINGLE LAYER OF 6-MIL POLYETHYLENE SHEETING, A NEGATIVE PRESSURE ENCLOSURE SYSTEM SHALL BE ESTABLISHED AS DESCRIBED IN SECTION 18.10 REMEDIATION AREA.

2. THE PORTION OF THE WEST WALL BETWEEN THE CABLE TRAY AND THE NORTH WALL, UP TO A HEIGHT OF 4', SHALL BE HEPA VACUUMED AND THEN WET WIPED WITH AN APPROVED CLEANING SOLUTION.

3. THE SOUTH WALL ABOVE THE DOOR TO ROOM 727, 3' WIDE TO A HEIGHT OF 3', SHALL BE HEPA VACUUMED AND THEN WET WIPED WITH AN APPROVED CLEANING SOLUTION.

ROOM 728

1. A MISCONTAINMENT SHALL BE ESTABLISHED CONSISTING OF A SINGLE LAYER OF 6-MIL POLYETHYLENE SHEETING, A NEGATIVE PRESSURE ENCLOSURE SYSTEM SHALL BE ESTABLISHED AS DESCRIBED IN SECTION 18.10 REMEDIATION AREA.

2. THE EAST (ELEVATOR SHAFT) WALL, UP TO A HEIGHT OF 4', SHALL BE HEPA VACUUMED AND THEN WET WIPED WITH AN APPROVED CLEANING SOLUTION.

3. THE SOUTH (ELEVATOR SHAFT) WALL, UP TO A HEIGHT OF 4', SHALL BE HEPA VACUUMED AND THEN WET WIPED WITH AN APPROVED CLEANING SOLUTION.

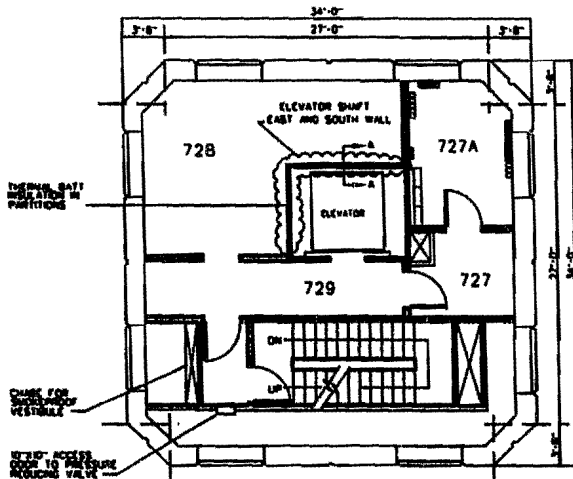

SEVENTH FLOOR SHAFT PLAN

SCALE: 1" = 1'-0"
SCALE IN FEET

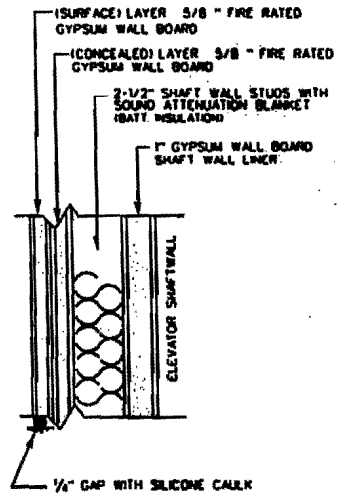

DETAIL A - PARTITION WALL

1 1/2 HOUR FIRE RATING
NOT TO SCALE

| | |
|---|-----------------|
| DEPARTMENT OF TRANSPORTATION REGIONAL AIRPORT ADMINISTRATION | |
| CHALLENGE NUMBER | DISPOSAL NUMBER |
| MOISTURE ORANGE REMEDIATION 7TH FLOOR ATCT DETROIT METRO WAREHOUSE COUNTY AIRPORT DETROIT, MICHIGAN | |
| DATE | BY |
| 11/15/2008 | DTW-64421-007 |

SCOPE OF WORK

FLOOR 8th

1. PRIOR TO PERFORMING MICROBIOLOGICAL REMEDIATION PROCEDURES THE CONTRACTOR SHALL SEAL ALL CRITICAL PENETRATIONS AND OPENINGS TO THE WORK AREA WITH A MINIMUM OF TWO LAYERS OF 6-MIL POLYETHYLENE AND SHALL BE RESPONSIBLE FOR ENSURING ADJACENT AREAS ARE NOT EXPOSED TO THE MICROBIOLOGICAL CONTAMINATION DURING THE REMEDIATION.
2. REMOVE ANY MCM BETWEEN THE BOTTOM METAL RUNNER/TRACK AND THE CONCRETE FLOOR BETWEEN THE TOP METAL RUNNER/TRACK AND THE STRUCTURAL DECK AND BETWEEN THE METAL STUD AND EXTERIOR CONCRETE WALL.
3. THE CONTRACTOR SHALL MINIMIZE DUST GENERATION AND USE THE TECHNIQUES OUTLINED IN GUIDE FOR DUST PREVENTION AND SUPPRESSION.
4. ALL REMOVALS AND OTHER CLEANING PROCEDURES SHALL BE CONDUCTED AT NIGHT BETWEEN THE HOURS OF 11:00 PM AND 6:00 AM. NEGATIVE AIR PRESSURE CONTROLS SHALL BE TURNED ON AND OPERATED THROUGHOUT THE REMEDIATION PROCESS, UNLESS OTHERWISE POSSIBLE. OTHERWISE DISCHARGED THROUGH A SECOND HEPA FILTER IN ORDER TO PERMIT RECIRCULATION OF AIR INSIDE THE BUILDING.

ROOM 827

1. THE CONTRACTOR SHALL PROVIDE ADDITIONAL CLEANING PROCEDURES AND PIPE INSULATION REMOVAL/REPLACEMENT.
2. APPROXIMATELY 4 LINEAR FEET OF 1" WATER STAMPED AND/OR CONTAMINATED CHILLED AND HEATING WATER PIPE INSULATION SHALL BE REMOVED AND REPLACED.

ROOM 828

1. A W/CONTAMINANT SHALL BE ESTABLISHED CONSISTING OF A SINGLE LAYER OF 6-MIL POLYETHYLENE SHEETING, A NEGATIVE PRESSURE INCLUDING SYSTEM SHALL BE ESTABLISHED AS DESCRIBED IN SECTION 8.6.5 REMEDIATION AREA.
2. THE PORTION OF THE EAST WALL BETWEEN THE SOUTH WALL AND STAIRWELL DOORFRAME SHALL BE WIPED TO A HEIGHT OF 8'. SHALL BE HEPA VACUUMED AND THEN WET WIPED WITH AN APPROVED CLEANING SOLUTION.
3. THE ADJACENT SOUTH WALL FROM THE SOUTHEAST CORNER WESTWARD 1' WIDE TO A HEIGHT OF 8' SHALL BE HEPA VACUUMED AND THEN WET WIPED WITH AN APPROVED CLEANING SOLUTION.

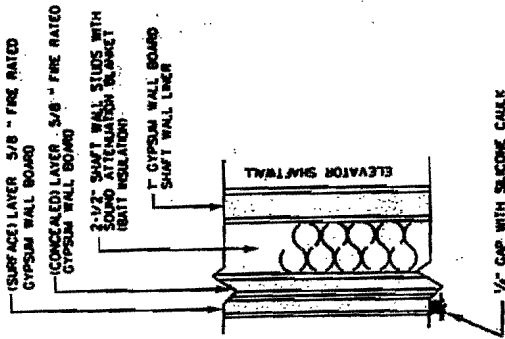

DETAIL A - PARTITION WALL
1/2" THICK FIRE RATED
NOT TO SCALE

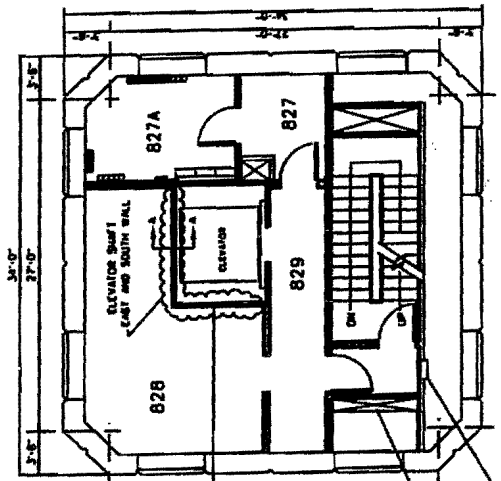

EIGHTH FLOOR SHAFT PLAN

SCALE: 1/4" = 1'-0"
NOT TO SCALE

| NO. | DESCRIPTION | DATE | BY | CHECKED | DATE |
|-----|-------------------------|------|----|---------|------|
| 1 | ISSUED FOR PERMITTING | | | | |
| 2 | ISSUED FOR BIDDING | | | | |
| 3 | ISSUED FOR CONSTRUCTION | | | | |
| 4 | ISSUED FOR AS-BUILT | | | | |
| 5 | ISSUED FOR ARCHIVE | | | | |

SCOPE OF WORK

FLOOR 9:

1. PRIOR TO PERFORMING MICROBIOLOGICAL REMEDIATION PROCEDURES, THE CONTRACTOR SHALL SEAL ALL CRITICAL PENETRATIONS AND OPENINGS TO THE WORK AREA WITH A MINIMUM OF TWO LAYERS OF 6-MIL POLYETHYLENE, AND SHALL BE RESPONSIBLE FOR ENSURING ADJOINING AREAS ARE NOT EXPOSED TO THE MICROBIOLOGICAL CONTAMINATION DURING THE REMEDIATION.

2. REMOVE ANY MEM BETWEEN THE BOTTOM METAL RUNNER/TRACK AND THE CONCRETE FLOOR BETWEEN THE TOP METAL RUNNER/TRACK AND THE STRUCTURAL DECK; AND BETWEEN THE METAL STUD AND EXTERIOR CONCRETE WALL.

3. THE CONTRACTOR SHALL MINIMIZE DUST GENERATION AND USE THE METHODOLOGIES OUTLINED IN GMR#E FOR DUST PREVENTION AND SUPPRESSION.

4. ALL REMOVALS AND OTHER CLEANING PROCEDURES SHALL BE CONDUCTED AT NIGHT BETWEEN THE HOURS OF 11:00 PM AND 6:00 AM. NEGATIVE AIR PRESSURE EQUIPMENT SHALL BE EQUIPPED WITH A HEPA FILTER AND DISCHARGED OUTSIDE OF THE BUILDING WHENEVER POSSIBLE, OTHERWISE DISCHARGED THROUGH A SECOND HEPA FILTER IN ORDER TO PERMIT RECIRCULATION OF AIR INSIDE THE BUILDING.

ROOM 927

1. THE CONTRACTOR SHALL PROVIDE ADDITIONAL CLEANING PROCEDURES AND PIPE INSULATION REMOVAL/REPLACEMENT.

2. APPROXIMATELY 4 LINEAR FEET OF 1" WATER STAINED AND/OR CONTAMINATED CHILLED AND HEATING WATER PIPE INSULATION SHALL BE REMOVED AND REPLACED.

ROOM 928

1. A CONTAINMENT AND NEGATIVE PRESSURE ENCLOSURE SYSTEM SHALL BE ESTABLISHED AS DESCRIBED IN SECTION 18.10 REMEDIATION AREA. A DECONTAMINATION UNIT SHALL BE ESTABLISHED AS DESCRIBED IN SECTION 18.11 DECONTAMINATION.

2. CLEANUP AND REMOVAL OF MOISTURE AND MICROBIOLOGICAL CONTAMINATED GYPSUM BOARD, SHAFT LINER, AND INSULATION IN THE DTW ATCT ROOMS 928, IN ACCORDANCE WITH THE GUIDELINES ESTABLISHED BY THE NEW YORK CITY DEPARTMENT OF HEALTH ENTITLED GUIDELINES ON ASSESSMENT AND REMEDIATION OF FUNGUS INDOOR ENVIRONMENTS (GARF#) (SEE ATTACHMENT D).

3. GYPSUM BOARD, SHAFT LINER, AND INSULATION TOTALING APPROXIMATELY 311 SQUARE FEET WILL BE REMOVED THIS AREA

A. THE EAST (ELEVATOR SHAFT) WALL, 8" WIDE TO A HEIGHT OF 5' (SURFACE LAYER), 8" WIDE TO A HEIGHT OF 4'6" (CONCEALED LAYER), AND 8" WIDE TO A HEIGHT OF 4' (SHAFT LINER).

B. THE SOUTH (ELEVATOR SHAFT) WALL, 10" WIDE TO A HEIGHT OF 5' (SURFACE LAYER), 10" WIDE TO A HEIGHT OF 4'6" (CONCEALED LAYER), AND 10" WIDE TO A HEIGHT OF 4' (SHAFT LINER).

C. THE NORTHWEST COLUMN BEAM ENCLOSURE, ON THE NORTH WALL, 6" WIDE TO A HEIGHT OF 3' (SURFACE LAYER), 6" WIDE TO A HEIGHT OF 2'6" (CONCEALED LAYER), AND 6" WIDE TO A HEIGHT OF 2' (SHAFT LINER).

D. THE WEST WALL, 3" WIDE TO A HEIGHT OF 3' (SURFACE LAYER), 3" WIDE TO A HEIGHT OF 2'6" (CONCEALED LAYER), AND 3" WIDE TO A HEIGHT OF 2' (SHAFT LINER).

E. ELEVATOR SHAFT LINER REMOVAL AND REPLACEMENT REQUIRES COORDINATION WITH THE ELEVATOR MAINTENANCE CO. AND AIR TRAFFIC TO SCHEDULE LIMITED ELEVATOR SHUTDOWN TIME.

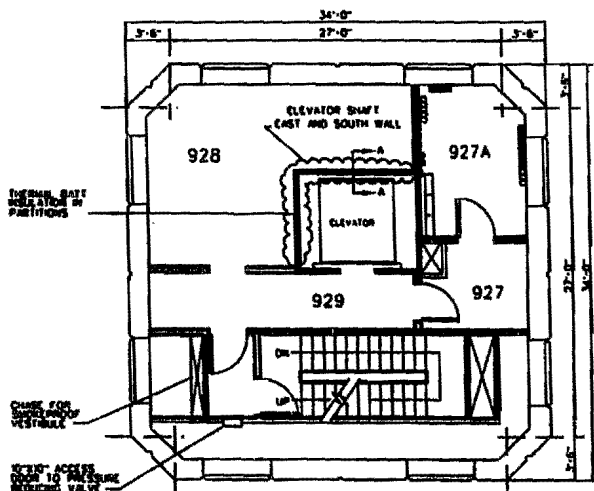

NINTH FLOOR SHAFT PLAN

SCALE: 1/4" = 1'-0"
SCALE IN FEET

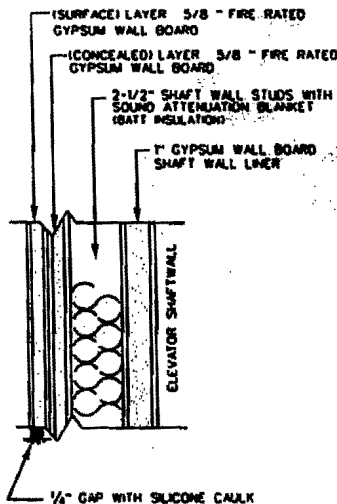

DETAIL A - PARTITION WALL
(2 HOUR FIRE RATING)
NOT TO SCALE

| | | |
|--|---------|-----------|
| DEPARTMENT OF TRANSPORTATION FEDERAL AVIATION ADMINISTRATION | | FORM 1005 |
| MOISTURE DAMAGE REMEDIATION 9TH FLOOR ATCT DETROIT METRO WAREHOUSE AIRPORT DETROIT, MICHIGAN | | |
| NO. 1 | NO. 2 | NO. 3 |
| NO. 4 | NO. 5 | NO. 6 |
| NO. 7 | NO. 8 | NO. 9 |
| NO. 10 | NO. 11 | NO. 12 |
| NO. 13 | NO. 14 | NO. 15 |
| NO. 16 | NO. 17 | NO. 18 |
| NO. 19 | NO. 20 | NO. 21 |
| NO. 22 | NO. 23 | NO. 24 |
| NO. 25 | NO. 26 | NO. 27 |
| NO. 28 | NO. 29 | NO. 30 |
| NO. 31 | NO. 32 | NO. 33 |
| NO. 34 | NO. 35 | NO. 36 |
| NO. 37 | NO. 38 | NO. 39 |
| NO. 40 | NO. 41 | NO. 42 |
| NO. 43 | NO. 44 | NO. 45 |
| NO. 46 | NO. 47 | NO. 48 |
| NO. 49 | NO. 50 | NO. 51 |
| NO. 52 | NO. 53 | NO. 54 |
| NO. 55 | NO. 56 | NO. 57 |
| NO. 58 | NO. 59 | NO. 60 |
| NO. 61 | NO. 62 | NO. 63 |
| NO. 64 | NO. 65 | NO. 66 |
| NO. 67 | NO. 68 | NO. 69 |
| NO. 70 | NO. 71 | NO. 72 |
| NO. 73 | NO. 74 | NO. 75 |
| NO. 76 | NO. 77 | NO. 78 |
| NO. 79 | NO. 80 | NO. 81 |
| NO. 82 | NO. 83 | NO. 84 |
| NO. 85 | NO. 86 | NO. 87 |
| NO. 88 | NO. 89 | NO. 90 |
| NO. 91 | NO. 92 | NO. 93 |
| NO. 94 | NO. 95 | NO. 96 |
| NO. 97 | NO. 98 | NO. 99 |
| NO. 100 | NO. 101 | NO. 102 |

SCOPE OF WORK

FLOOR 10:

1. PRIOR TO PERFORMING MICROBIOLOGICAL REMEDIATION PROCEDURES, THE CONTRACTOR SHALL SEAL ALL CRITICAL PENETRATIONS AND OPENINGS TO THE WORK AREA WITH A MINIMUM OF TWO LAYERS OF 6-MIL POLYETHYLENE, AND SHALL BE RESPONSIBLE FOR ENSURING ADJOINING AREAS ARE NOT EXPOSED TO THE MICROBIOLOGICAL CONTAMINATION DURING THE REMEDIATION.
2. REMOVE ANY MCM BETWEEN THE BOTTOM METAL RUNNER/TRACK AND THE CONCRETE FLOOR; BETWEEN THE TOP METAL RUNNER/TRACK AND THE STRUCTURAL DECK; AND BETWEEN THE METAL STUD AND EXTERIOR CONCRETE WALL.
3. THE CONTRACTOR SHALL MINIMIZE DUST GENERATION AND USE THE METHODOLOGIES OUTLINED IN GARFIE FOR DUST PREVENTION AND SUPPRESSION.
4. ALL REMOVALS AND OTHER CLEANING PROCEDURES SHALL BE CONDUCTED AT NIGHT BETWEEN THE HOURS OF 11:00 PM AND 6:00 AM. ALL NEGATIVE AIR PRESSURE EQUIPMENT SHALL BE EQUIPPED WITH A HEPA FILTER AND DISCHARGED OUTSIDE OF THE BUILDING WHENEVER POSSIBLE, OTHERWISE DISCHARGED THROUGH A SECOND HEPA FILTER IN ORDER TO PERMIT RECIRCULATION OF AIR INSIDE THE BUILDING.

ROOM 1028

1. A MINICONTAINMENT SHALL BE ESTABLISHED CONSISTING OF A SINGLE LAYER OF 6-MIL POLYETHYLENE SHEETING. A NEGATIVE PRESSURE ENCLOSURE SYSTEM SHALL BE ESTABLISHED AS DESCRIBED IN SECTION 10.10 REMEDIATION AREA.
2. THE NORTH WALL SHAFT LINER IN ITS ENTIRETY SHALL BE HEPA VACUUMED AND THEN WET WIPED WITH AN APPROVED CLEANING SOLUTION.

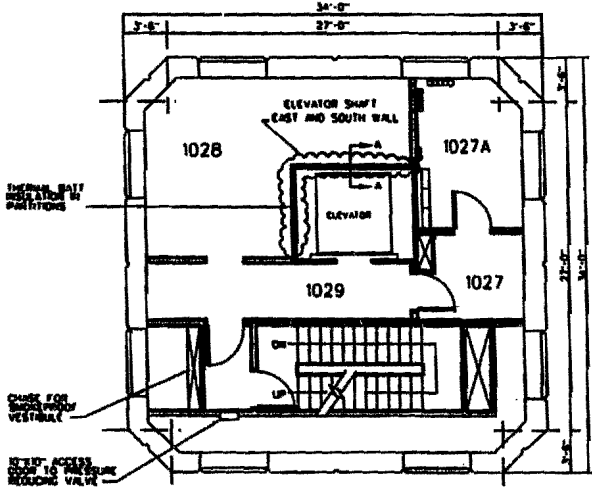

TENTH FLOOR SHAFT PLAN
SCALE: 1/4" = 1'-0"
1/4" = 1'-0"

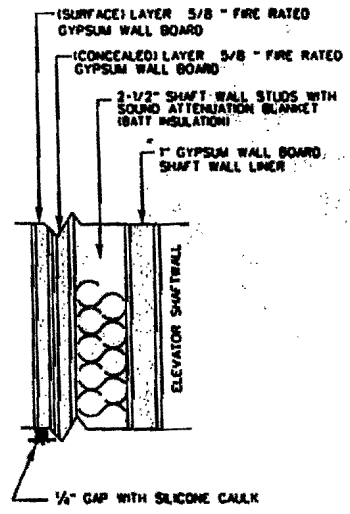

DETAIL A - PARTITION WALL
12 HOUR FIRE RATING
NOT TO SCALE

| | | | |
|---|-------|-----------------|--------------|
| DEPARTMENT OF TRANSPORTATION FEDERAL AVIATION ADMINISTRATION | | ISSUED FOR: [] | REVISED: [] |
| MOISTURE DAMAGE REMEDIATION 10TH FLOOR ATCT DETROIT METRO WAYNE COUNTY AIRPORT DETROIT, MICHIGAN | | | |
| PROJECT NUMBER: | DATE: | DRAWN BY: | SCALE: |
| | | | |
| | | | |
| | | | |
| | | | |
| | | | |

ENGINEERING COST ESTIMATE

DATE PREPARED

7/15/2008

SHEET 1 OF 1

| PROJECT | | Remediation | | DRAWING REF. NO. | | BASIS FOR ESTIMATE | | <input type="checkbox"/> PROJECT DESIGN <input checked="" type="checkbox"/> STANDARD DESIGN <input type="checkbox"/> OTHER (SPECIFY) | |
|---------------------------------|-----------|--------------------------|------------------|------------------|---------------|--|-------------------|--|--------------------|
| LOCATION | | DTW ATCT | | SPEC. REF. NO. | | <input type="checkbox"/> PROJECT DESIGN <input checked="" type="checkbox"/> GOVERNMENT ESTIMATE | | | |
| PREPARING ORGANIZATION UNIT | | AGL-473B | | ESTIMATOR | | D. Morse | | CHECKED BY | |
| CLASS OF WORK | | Environmental/Structural | | | | | | | |
| ITEM | QUANTITY | | MATERIAL COST-\$ | | LABOR COST-\$ | | EQUIPMENT COST-\$ | | TOTAL ITEM COST-\$ |
| | UNT MEAS. | NO. UNITS | PER UNIT | TOTAL | PER UNIT | TOTAL | PER UNIT | TOTAL | |
| Remediation | | | | | | | | | |
| Drywall Removal | SF | 500.00 | \$0.10 | \$50.00 | \$0.25 | \$125.00 | | \$0.00 | \$175.00 |
| Drywall Installation 5/8" | SF | 275.00 | \$1.08 | \$297.00 | \$2.59 | \$712.25 | | \$0.00 | \$1,009.25 |
| Drywall Installation 1" | SF | 200.00 | \$1.38 | \$276.00 | \$3.16 | \$632.00 | | \$0.00 | \$908.00 |
| Batt Insulation | SF | 125.00 | \$0.45 | \$56.25 | \$0.35 | \$43.75 | | \$0.00 | \$100.00 |
| Pipe insulation removal | LF | 100.00 | \$0.93 | \$93.00 | \$13.05 | \$1,305.00 | | \$0.00 | \$1,398.00 |
| Pipe Insulation replacement 11" | LF | 40.00 | \$0.93 | \$37.20 | \$0.70 | \$28.00 | | \$0.00 | \$65.20 |
| Pipe Insulation replacement 18" | LF | 60.00 | \$0.93 | \$55.80 | \$0.70 | \$42.00 | | \$0.00 | \$97.80 |
| Surface wipe and HEPA vac | SF | 500.00 | \$0.10 | \$50.00 | \$0.42 | \$210.00 | \$0.10 | \$50.00 | \$310.00 |
| Mini Containment | SF | 1300.00 | \$4.00 | \$5,200.00 | \$3.00 | \$3,900.00 | | \$0.00 | \$9,100.00 |
| Full Containment | SF | 2200.00 | \$7.00 | \$15,400.00 | \$10.00 | \$22,000.00 | | | \$37,400.00 |
| Replace outlet face plates | EA | 20.00 | \$0.75 | \$15.00 | \$0.30 | \$6.00 | | \$0.00 | \$21.00 |
| Clear debris bags | ROLL | 2.00 | \$40.00 | \$80.00 | | \$0.00 | | \$0.00 | \$80.00 |
| Mobilization | EA | 1.00 | | \$0.00 | \$1,500.00 | \$1,500.00 | | \$0.00 | \$1,500.00 |
| Elevator Technician | HR | 16.00 | | \$0.00 | \$25.00 | \$400.00 | | \$0.00 | \$400.00 |
| Supervisor | HR | 40.00 | | \$0.00 | \$87.60 | \$3,504.00 | | \$0.00 | \$3,504.00 |
| Crew | HR | 40.00 | | \$0.00 | \$82.80 | \$3,312.00 | | \$0.00 | \$3,312.00 |
| Duct Tape | ROLL | 10.00 | \$10.00 | \$100.00 | | \$0.00 | | \$0.00 | \$100.00 |
| Negative air machine w/ filter | DAY | 5.00 | | \$0.00 | | \$0.00 | \$100.00 | \$500.00 | \$500.00 |
| Dehumidifier | DAY | 5.00 | | \$0.00 | | \$0.00 | \$35.00 | \$175.00 | \$175.00 |
| HEPA vac | DAY | 5.00 | | \$0.00 | | \$0.00 | \$30.00 | \$150.00 | \$150.00 |
| SUBTOTAL = \$ | | | | | | | | | 60,305.25 |
| Night Differential 25% | | | | | | | | | 15,076.31 |
| OH&P 25% | | | | | | | | | 18,845.39 |
| TOTAL = \$ | | | | | | | | | 94,226.95 |

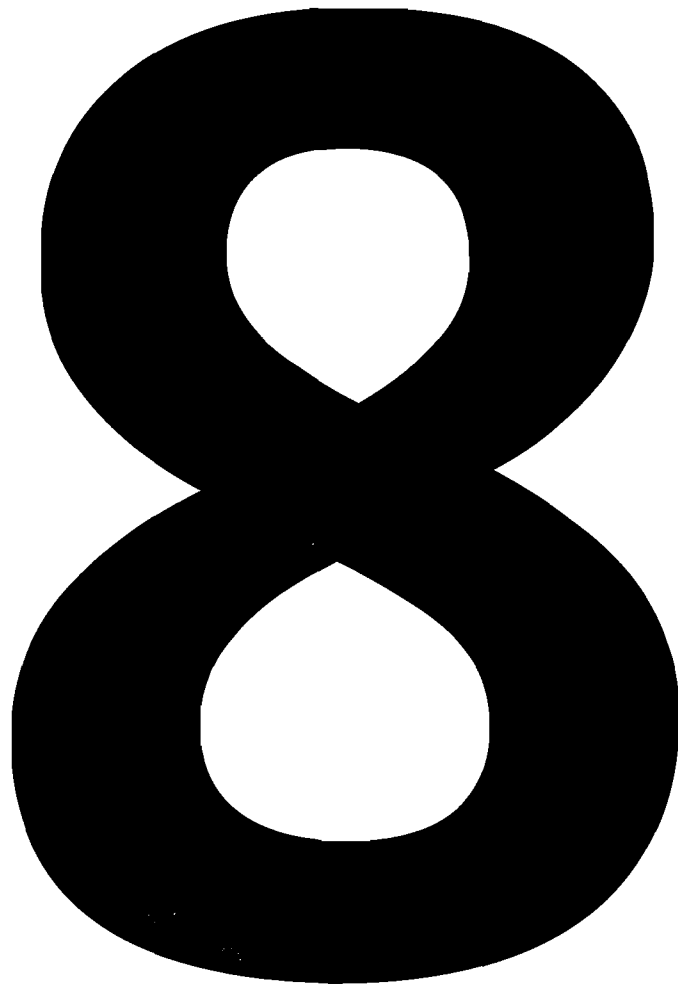

8
12



Federal Aviation Administration
AGL-473 PROJECT REVIEW TRACKING

This project will not advance until this form has been returned to AGL-473.
COMMENTS RECEIVED

**PROJECT INFORMATION – PROJECT TYPE GENERAL CONSTRUCTION,
STRUCTURAL, SPECIALTY CONTRACTOR (MICROBIOLOGICAL
REMEDATION)**

| | |
|--------------------------|-----------------------------|
| Location | Detroit, MI |
| Facility | DTW TOWB |
| Project Title | MOISTURE DAMAGE REMEDIATION |
| JON | |
| Design Engineer | B. Hebert, D. Morse |
| Project Reviewer | B. Hebert, Wayne Vogelsburg |
| Courtesy Copy (FYI Only) | |

PROJECT REVIEW PACKAGE INCLUDES THE FOLLOWING:

| Item # | Document Title | Included |
|--------|---|--|
| 1. | Scope of Work | 08/08/08 |
| 2. | Specifications – FAA-DTW-ATCT-2697 | 08/08/08 |
| 3. | Drawings | |
| | DWG NO | DWG TITLE |
| | GL-D-414C-CSP | CONSTRUCTION SAFETY PLAN |
| | DTW-D-ATCT-A03 | MOISTURE DAMAGE REMEDIATION 3 RD FL. |
| | DTW-D-ATCT-A04 | MOISTURE DAMAGE REMEDIATION 4 TH FL. |
| | DTW-D-ATCT-A05 | MOISTURE DAMAGE REMEDIATION 5 TH FL. |
| | DTW-D-ATCT-A06 | MOISTURE DAMAGE REMEDIATION 6 TH FL. |
| | DTW-D-ATCT-A07 | MOISTURE DAMAGE REMEDIATION 7 TH FL. |
| | DTW-D-ATCT-A08 | MOISTURE DAMAGE REMEDIATION 8 TH FL. |
| | DTW-D-ATCT-A09 | MOISTURE DAMAGE REMEDIATION 9 TH FL. |
| | DTW-D-ATCT-A10 | MOISTURE DAMAGE REMEDIATION 10 TH FL. |
| | DTW-D-ATCT-A11 | MOISTURE DAMAGE REMEDIATION DETAILS |
| 4. | Government Furnish Equipment | N/A |
| 5. | Construction Safety Plan – In Drawings | |
| 6. | Cost Estimate | 08/07/08 |
| 7a. | Form 3900.57 - Environmental & Safety Compliance Check List | 07/18/08 |
| 7b. | Great Lakes EHS Checklist | 07/18/08 |
| 7c. | Environmental Checklist for Ventilation and Airborne Contaminants | 07/18/08 |
| 8. | Form 7460 - Construction on Airports | N/A |
| 9. | Purchase Request Data | 08/08/08 |
| 10. | Capitalization Authorization Form | 07/18/08 |
| 11. | County Permit Form | 08/06/08 |

Return this form to: FAA/AGL-473
Willow Run Airport East
8808 Beck Road
Belleville, MI 48111
Attn: Diane Morse

PERFORMANCE OF WORK ITEMS

MICROBIOLOGICAL REMEDIATION PROJECT AT DETROIT METROPOLITAN AIRPORT AIR TRAFFIC CONTROL TOWER

The contractor shall provide all the services, equipment, supplies, materials, and labor required. Work shall include, but not limited to, the following:

ALL FLOORS:

1. Prior to performing microbiological remediation procedures, the contractor shall seal all critical penetrations and openings to the work area with a minimum of two layers of 6-mil polyethylene, and shall be responsible for ensuring adjoining areas are not exposed to the microbiological contamination during the remediation.
2. Remove any MCM between the bottom metal runner/track and the concrete floor; between the top metal runner/track and the structural deck; and between the metal stud and exterior concrete wall.
3. The contractor shall minimize dust generation and use the methodologies outlined in *Guidelines on Assessment and Remediation of Fungi in Indoor Environments* (GARFIE) (See Specification Attachment 1) for dust prevention and suppression.
4. All removals and other cleaning procedures shall be conducted at night between the hours of 11:00 pm and 6:00 am. Negative air pressure equipment shall be equipped with a HEPA filter and discharged outside of the building whenever possible, otherwise discharged through a second HEPA filter in order to permit recirculation of air inside the building.
5. Once the mold has been removed and clearance has been achieved, and the stained surfaces have been cleaned, then remove all partition walls, doors and door frames, except those around the elevator-core and stairwell.
6. Cut a 1/2" gap between the bottom of the gypsum board and the concrete deck. Fill the gap with a 2-hr fire-rated caulk in the remaining partition walls around the elevator core and stairwell corridor.
7. Paint elevator core exterior and stairwell corridor with mold resistant paint.
8. Furnish and install fire-rated access panels in the center of the north and east elevator core wall. The bottom of the panel shall be 24" above the floor. Do not penetrate the shaft liner. See detail "B" on drawing DTW -D-ATCT-A11.

FLOOR 3

ROOM 327

1. The contractor shall provide additional cleaning procedures and pipe insulation removal/replacement.

2. Approximately 15 linear feet of 18", water stained and/or contaminated chilled and heating water pipe insulation shall be removed and replaced.

ROOM 328

1. A mini containment shall be established consisting of a single layer of 6-mil polyethylene sheeting. A negative pressure enclosure system shall be established as described in section 1B.9 Remediation Area.
2. The east (elevator shaft) wall, up to a height of 2', and the south (elevator shaft) wall, up to a height of 2', shall be HEPA vacuumed and then wet wiped with an approved cleaning solution.

FLOOR 4

ROOM 427

1. The contractor shall provide additional cleaning procedures and pipe insulation removal/replacement.
2. Approximately 4 linear feet of 11" and 6 linear feet of 18" water stained and/or contaminated chilled and heating water pipe insulation shall be removed and replaced.

ROOM 428

1. A containment and negative pressure enclosure system shall be established as described in section 1B.9 Remediation Area. A decontamination unit shall be established as described in section 1B.10 Decontamination Area.
2. Cleanup and removal of moisture and microbiological contaminated gypsum board, shaft liner, and insulation in the DTW ATCT room 428 in accordance with the guidelines established by the New York City Department of Health entitled *Guidelines on Assessment and Remediation of Fungi in Indoor Environments* (GARFIE) (See Specification Attachment 1).
3. Remove and replace gypsum board, shaft liner, and insulation totaling approximately 243 square feet:
 - a. The east (elevator shaft) wall, 8' wide to a height of 5' (surface layer), 8' wide to a height of 4'6" (concealed layer), and 8' wide to a height of 4' (shaft liner).
 - b. The south (elevator shaft) wall, 10' wide to a height of 5' (surface layer), 10' wide to a height of 4'6" (concealed layer), and 10' wide to a height of 4' (shaft liner).
 - c. **Elevator Shaft liner removal and replacement requires coordination with the Elevator Maintenance company and Air Traffic to schedule limited elevator shutdown time.**

FLOOR 5

ROOM 527

1. A mini containment shall be established consisting of a single layer of 6-mil polyethylene sheeting but a negative pressure enclosure system is not required. Mist any contaminated areas prior to removal. Upon completion, the work area shall be HEPA vacuumed and then wet wiped with a detergent solution.
2. Cleanup and removal of moisture and microbiological contaminated gypsum board, shaft liner, and insulation in accordance with the guidelines established by the New York City Department of Health entitled *Guidelines On Assessment And Remediation Of Fungi In Indoor Environments* (GARFIE) (See Specification Attachment 1).
3. Approximately 4 linear feet of 11" and 25 linear feet of 18" water stained and/or contaminated chilled and heating water pipe insulation shall be removed and replaced.
4. Remove and replace gypsum board and insulation totaling approximately 15 square feet, on the north wall, between the east wall and door to Room 527A, 2' wide to a height of 4' (surface layer) and 2' wide to a height of 3'6" (concealed layer).

ROOM 527A

1. A mini containment shall be established consisting of a single layer of 6-mil polyethylene sheeting but a negative pressure enclosure system is not required. Mist any contaminated areas prior to removal. Upon completion, the work area shall be HEPA vacuumed and then wet wiped with a detergent solution.
2. Cleanup and removal of moisture and microbiological contaminated gypsum board, shaft liner, and insulation in accordance with the guidelines established by the New York City Department of Health Entitled *Guidelines on Assessment and Remediation of Fungi in Indoor Environments* (GARFIE) (See Specification Attachment 1).
3. Remove and replace gypsum board and insulation totaling approximately 5 square feet on the south wall, between the east wall and the door to Room 527, 2' wide to a height of 18" (surface layer) and 2' wide to a height of 12" (concealed layer).

ROOM 529

1. A mini containment shall be established consisting of a single layer of 6-mil polyethylene sheeting. A negative pressure enclosure system shall be established as described in section 1B.9 Remediation Area.
2. The portion of the east wall, between the south wall and stairwell doorframe, 2" wide to a height of 8', shall be HEPA vacuumed and then wet wiped with an approved cleaning solution.

FLOOR 6

ROOM 627

1. The contractor shall provide additional cleaning procedures and pipe insulation removal/replacement.
2. Approximately 20 linear feet of 11" and 25 linear feet of 18" water stained and/or contaminated chilled and heating water pipe insulation shall be removed and replaced.

ROOM 628

1. A mini containment shall be established consisting of a single layer of 6-mil polyethylene sheeting. A negative pressure enclosure system shall be established as described in section 1B.9 Remediation Area.
2. The east (elevator shaft) wall, up to a height of 4', shall be HEPA vacuumed and then wet wiped with an approved cleaning solution.
3. The south (elevator shaft) wall, up to a height of 4', shall be HEPA vacuumed and then wet wiped with an approved cleaning solution.

FLOOR 7

ROOM 727

1. The contractor shall provide additional cleaning procedures and pipe insulation removal/replacement.
2. Approximately 3 linear feet of 18" water stained and/or contaminated chilled and heating water pipe insulation shall be removed and replaced.

ROOM 727A

1. A mini containment shall be established consisting of a single layer of 6-mil polyethylene sheeting. A negative pressure enclosure system shall be established as described in section 1B.9 Remediation Area.
2. The portion of the west wall between the cable tray and the north wall, up to a height of 4', shall be HEPA vacuumed and then wet wiped with an approved cleaning solution.
3. The south wall above the door to room 727, 3' wide to a height of 3', shall be HEPA vacuumed and then wet wiped with an approved cleaning solution.

ROOM 728

1. A mini containment shall be established consisting of a single layer of 6-mil polyethylene sheeting. A negative pressure enclosure system shall be established as described in section 1B.9 Remediation Area.
2. The east (elevator shaft) wall, up to a height of 4', shall be HEPA vacuumed and then wet wiped with an approved cleaning solution.
3. The south (elevator shaft) wall, up to a height of 4', shall be HEPA vacuumed and then wet wiped with an approved cleaning solution.

FLOOR 8

ROOM 827

1. The contractor shall provide additional cleaning procedures and pipe insulation removal/replacement.
2. Approximately 4 linear feet of 11" water stained and/or contaminated chilled and heating water pipe insulation shall be removed and replaced.

ROOM 829

1. A mini containment shall be established consisting of a single layer of 6-mil polyethylene sheeting. A negative pressure enclosure system shall be established as described in section 1B.9 Remediation Area.
2. The portion of the east wall, between the south wall and stairwell doorframe, 2" wide to a height of 8', shall be HEPA vacuumed and then wet wiped with an approved cleaning solution.
3. The adjacent south wall, from the southeast corner westward, 1' wide to a height of 8', shall be HEPA vacuumed and then wet wiped with an approved cleaning solution.

FLOOR 9

ROOM 927

1. The contractor shall provide additional cleaning procedures and pipe insulation removal/replacement.
2. Approximately 4 linear feet of 11" water stained and/or contaminated chilled and heating water pipe insulation shall be removed and replaced.

ROOM 928

1. A containment and negative pressure enclosure system shall be established as described in section 1B.9 Remediation Area. A decontamination unit shall be established as described in section 1B.10 Decontamination Area.

2. Cleanup and removal of moisture and microbiological contaminated gypsum board, shaft liner, and insulation in the DTW ATCT rooms 928, in accordance with the guidelines established by the New York City Department of Health Entitled *Guidelines on Assessment and Remediation of Fungi in Indoor Environments* (GARFIE) attached and incorporated herein by reference (see attachment 1).
3. Remove and replace gypsum board, shaft liner, and insulation totaling approximately 311 square feet:
 - a. The east (elevator shaft) wall, 8' wide to a height of 5' (surface layer), 8' wide to a height of 4'6" (concealed layer), and 8' wide to a height of 4' (shaft liner).
 - b. The south (elevator shaft) wall, 10' wide to a height of 5' (surface layer), 10' wide to a height of 4'6" (concealed layer), and 10' wide to a height of 4' (shaft liner).
 - c. The northwest column beam enclosure, on the north wall, 6' wide to a height of 3' (surface layer), 6' wide to a height of 2'6" (concealed layer), and 6' wide to a height of 2' (shaft liner);
 - d. The west wall, 3' wide to a height of 3' (surface layer), 3' wide to a height of 2'6" (concealed layer), and 3' wide to a height of 2' (shaft liner).
 - e. **Elevator Shaft liner removal and replacement requires coordination with the Elevator Maintenance company and Air Traffic to schedule limited elevator shutdown time.**

FLOOR 10

ROOM 1028

1. A containment and negative pressure enclosure system shall be established as described in section 1B.9 Remediation Area. A decontamination unit shall be established as described in section 1B.10 Decontamination Area.
2. Cleanup and removal of moisture and microbiological contaminated gypsum board, shaft liner, and insulation in the DTW ATCT room 1028, in accordance with the guidelines established by the New York City Department of Health Entitled *Guidelines on Assessment and Remediation of Fungi in Indoor Environments* (GARFIE) attached and incorporated herein by reference (see attachment 1).
3. The north wall shaft liner in its entirety shall be HEPA vacuumed and then wet wiped with an approved cleaning solution.
4. Remove and dispose of existing carpet.
5. Remove and replace gypsum board, shaft liner, and insulation totaling approximately 792 square feet:
 - a. The north (elevator shaft) wall, 22' wide for the full height (surface layer, concealed layer and shaft liner).

Specification
Microbiological Remediation
at
Detroit Metropolitan Airport
Air Traffic Control Tower

FAA-DTW-ATCT-2697

August 08, 2008

U.S. DEPARTMENT OF TRANSPORTATION
FEDERAL AVIATION ADMINISTRATION
Infrastructure Support Detached Staff
Willow Run Airport, East
8808 Beck Road
Belleville, Michigan 48111

Diane I. Morse
(734) 487-7330

TABLE OF CONTENTS

DIVISION 1 - GENERAL REQUIREMENTS 3
 SECTION 1A - GENERAL REQUIREMENTS 3
 SECTION 1B - SPECIAL REQUIREMENTS 7
 SECTION 1C - SUBMITTALS 12
 SECTION 1D - ABATEMENT 13
 DIVISION 7 – THERMAL AND MOISTURE PROTECTION 15
 SECTION 7A – BUILDING INSULATION 15
 DIVISION 8 – DOORS AND WINDOWS 18
 SECTION 8A – ACCESS DOORS AND FRAMES 18
 DIVISION 9 - FINISHES 21
 SECTION 9A – GYPSUM BOARD 21
 SECTION 9B – PAINTING 29

DIVISION 1 - GENERAL REQUIREMENTS
SECTION 1A - GENERAL REQUIREMENTS

- 1A.1 **Summary of Work.** The work described consists of furnishing all necessary materials, labor, equipment, tools and supervision to remove and replace portions of the airport traffic control tower drywall. The project is located in Romulus, Michigan.
- 1A.2 **Scope of Work.** The Contractor is required to furnish all labor, materials, services, equipment, insurance, and perform all the work to remove and dispose of all microbiological contaminated materials (MCM) and microbiological contaminated elements (MCE) described in this Scope of Work (SOW). The Contractor shall be responsible for:

These specifications, together with other referenced documents, standards, and drawings in the contract documents, cover the requirements for all work associated with the drywall replacement.

ALL FLOORS:

1. Prior to performing microbiological remediation procedures, the contractor shall seal all critical penetrations and openings to the work area with a minimum of two layers of 6-mil polyethylene, and shall be responsible for ensuring adjoining areas are not exposed to the microbiological contamination during the remediation.
2. Remove any MCM between the bottom metal runner/track and the concrete floor; between the top metal runner/track and the structural deck; and between the metal stud and exterior concrete wall.
3. The contractor shall minimize dust generation and use the methodologies outlined in *Guidelines on Assessment and Remediation of Fungi in Indoor Environments* (GARFIE) (See Specification Attachment 1) for dust prevention and suppression.
4. All removals and other cleaning procedures shall be conducted at night between the hours of 11:00 pm and 6:00 am. Negative air pressure equipment shall be equipped with a HEPA filter and discharged outside of the building whenever possible, otherwise discharged through a second HEPA filter in order to permit recirculation of air inside the building.
5. Once the mold has been removed and clearance has been achieved, and the stained surfaces have been cleaned, then remove all partition walls, doors and door frames, except those around the elevator core and stairwell.
6. Cut a 1/2" gap between the bottom of the gypsum board and the concrete deck. Fill the gap with a 2-hr fire-rated caulk in the remaining partition walls around the elevator core and stairwell corridor.
7. Paint elevator core exterior and stairwell corridor with mold resistant paint.
8. Furnish and install fire-rated access panels in the center of the north and east elevator core wall. The bottom of the panel shall be 24" above the floor. Do not penetrate the shaft liner. See detail "B" on drawing DTW -D-ATCT-A11.

FLOOR 3

ROOM 327

1. The contractor shall provide additional cleaning procedures and pipe insulation removal/replacement.
2. Approximately 15 linear feet of 18", water stained and/or contaminated chilled and heating water pipe insulation shall be removed and replaced.

ROOM 328

1. A mini containment shall be established consisting of a single layer of 6-mil polyethylene sheeting. A negative pressure enclosure system shall be established as described in section 1B.9 Remediation Area.
2. The east (elevator shaft) wall, up to a height of 2', and the south (elevator shaft) wall, up to a height of 2', shall be HEPA vacuumed and then wet wiped with an approved cleaning solution.

FLOOR 4
ROOM 427

1. The contractor shall provide additional cleaning procedures and pipe insulation removal/replacement.
2. Approximately 4 linear feet of 11" and 6 linear feet of 18" water stained and/or contaminated chilled and heating water pipe insulation shall be removed and replaced.

ROOM 428

1. A containment and negative pressure enclosure system shall be established as described in section 1B.9 Remediation Area. A decontamination unit shall be established as described in section 1B.10 Decontamination Area.
2. Cleanup and removal of moisture and microbiological contaminated gypsum board, shaft liner, and insulation in the DTW ATCT room 428 in accordance with the guidelines established by the New York City Department of Health entitled *Guidelines on Assessment and Remediation of Fungi in Indoor Environments* (GARFIE) (See Specification Attachment 1).
3. Remove gypsum board, shaft liner, and insulation totaling approximately 243 square feet:
 - a. The east (elevator shaft) wall, 8' wide to a height of 5' (surface layer), 8' wide to a height of 4'6" (concealed layer), and 8' wide to a height of 4' (shaft liner).
 - b. The south (elevator shaft) wall, 10' wide to a height of 5' (surface layer), 10' wide to a height of 4'6" (concealed layer), and 10' wide to a height of 4' (shaft liner).
 - c. **Elevator Shaft liner removal and replacement requires coordination with the Elevator Maintenance company and Air Traffic to schedule limited elevator shutdown time.**

FLOOR 5
ROOM 527

1. A mini containment shall be established consisting of a single layer of 6-mil polyethylene sheeting but a negative pressure enclosure system is not required. Mist any contaminated areas prior to removal. Upon completion, the work area shall be HEPA vacuumed and then wet wiped with a detergent solution.
2. Cleanup and removal of moisture and microbiological contaminated gypsum board, shaft liner, and insulation in accordance with the guidelines established by the New York City Department of Health entitled *Guidelines on Assessment and Remediation of Fungi in Indoor Environments* (GARFIE) (See Specification Attachment 1).
3. Approximately 4 linear feet of 11" and 25 linear feet of 18" water stained and/or contaminated chilled and heating water pipe insulation shall be removed and replaced.
4. Remove gypsum board and insulation totaling approximately 15 square feet, on the north wall, between the east wall and door to Room 527A, 2' wide to a height of 4' (surface layer) and 2' wide to a height of 3'6" (concealed layer).

ROOM 527A

1. A mini containment shall be established consisting of a single layer of 6-mil polyethylene sheeting but a negative pressure enclosure system is not required. Mist any contaminated areas prior to removal. Upon completion, the work area shall be HEPA vacuumed and then wet wiped with a detergent solution.
2. Cleanup and removal of moisture and microbiological contaminated gypsum board, shaft liner, and insulation in accordance with the guidelines established by the New York City Department of Health Entitled *Guidelines on Assessment and Remediation of Fungi in Indoor Environments* (GARFIE) (See Specification Attachment 1).
3. Remove gypsum board and insulation totaling approximately 5 square feet on the south wall, between the east wall and the door to Room 527, 2' wide to a height of 18" (surface layer) and 2' wide to a height of 12" (concealed layer).

ROOM 529

1. A mini containment shall be established consisting of a single layer of 6-mil polyethylene sheeting. A negative pressure enclosure system shall be established as described in section 1B.9 Remediation Area.
2. The portion of the east wall, between the south wall and stairwell doorframe, 2' wide to a height of 8', shall be HEPA vacuumed and then wet wiped with an approved cleaning solution.

FLOOR 6
ROOM 627

1. The contractor shall provide additional cleaning procedures and pipe insulation removal/replacement.
2. Approximately 20 linear feet of 11" and 25 linear feet of 18" water stained and/or contaminated chilled and heating water pipe insulation shall be removed and replaced.

ROOM 628

1. A mini containment shall be established consisting of a single layer of 6-mil polyethylene sheeting. A negative pressure enclosure system shall be established as described in section 1B.9 Remediation Area.
2. The east (elevator shaft) wall, up to a height of 4', shall be HEPA vacuumed and then wet wiped with an approved cleaning solution.
3. The south (elevator shaft) wall, up to a height of 4', shall be HEPA vacuumed and then wet wiped with an approved cleaning solution.

FLOOR 7
ROOM 727

1. The contractor shall provide additional cleaning procedures and pipe insulation removal/replacement.
2. Approximately 3 linear feet of 18" water stained and/or contaminated chilled and heating water pipe insulation shall be removed and replaced.

ROOM 727A

1. A mini containment shall be established consisting of a single layer of 6-mil polyethylene sheeting. A negative pressure enclosure system shall be established as described in section 1B.9 Remediation Area.

2. The portion of the west wall between the cable tray and the north wall, up to a height of 4', shall be HEPA vacuumed and then wet wiped with an approved cleaning solution.
3. The south wall above the door to room 727, 3' wide to a height of 3', shall be HEPA vacuumed and then wet wiped with an approved cleaning solution.

ROOM 728

1. A mini containment shall be established consisting of a single layer of 6-mil polyethylene sheeting. A negative pressure enclosure system shall be established as described in section 1B.9 Remediation Area.
2. The east (elevator shaft) wall, up to a height of 4', shall be HEPA vacuumed and then wet wiped with an approved cleaning solution.
3. The south (elevator shaft) wall, up to a height of 4', shall be HEPA vacuumed and then wet wiped with an approved cleaning solution.

FLOOR 8 ROOM 827

1. The contractor shall provide additional cleaning procedures and pipe insulation removal/replacement.
2. Approximately 4 linear feet of 11" water stained and/or contaminated chilled and heating water pipe insulation shall be removed and replaced.

ROOM 829

1. A mini containment shall be established consisting of a single layer of 6-mil polyethylene sheeting. A negative pressure enclosure system shall be established as described in section 1B.9 Remediation Area.
2. The portion of the east wall, between the south wall and stairwell doorframe, 2" wide to a height of 8', shall be HEPA vacuumed and then wet wiped with an approved cleaning solution.
3. The adjacent south wall, from the southeast corner westward, 1' wide to a height of 8', shall be HEPA vacuumed and then wet wiped with an approved cleaning solution.

FLOOR 9 ROOM 927

1. The contractor shall provide additional cleaning procedures and pipe insulation removal/replacement.
2. Approximately 4 linear feet of 11" water stained and/or contaminated chilled and heating water pipe insulation shall be removed and replaced.

ROOM 928

1. A containment and negative pressure enclosure system shall be established as described in section 1B.9 Remediation Area. A decontamination unit shall be established as described in section 1B.10 Decontamination Area.
2. Cleanup and removal of moisture and microbiological contaminated gypsum board, shaft liner, and insulation in the DTW ATCT rooms 928, in accordance with the guidelines established by the New York City Department of Health Entitled *Guidelines on Assessment and Remediation of Fungi in Indoor Environments* (GARFIE) attached and incorporated herein by reference (see attachment 1).
3. Gypsum board, shaft liner, and insulation totaling approximately 311 square feet will be removed this area:

- a. The east (elevator shaft) wall, 8' wide to a height of 5' (surface layer), 8' wide to a height of 4'6" (concealed layer), and 8' wide to a height of 4' (shaft liner).
- b. The south (elevator shaft) wall, 10' wide to a height of 5' (surface layer), 10' wide to a height of 4'6" (concealed layer), and 10' wide to a height of 4' (shaft liner).
- c. The northwest column beam enclosure, on the north wall, 6' wide to a height of 3' (surface layer), 6' wide to a height of 2'6" (concealed layer), and 6' wide to a height of 2' (shaft liner);
- d. The west wall, 3' wide to a height of 3' (surface layer), 3' wide to a height of 2'6" (concealed layer), and 3' wide to a height of 2' (shaft liner).
- e. **Elevator Shaft liner removal and replacement requires coordination with the Elevator Maintenance company and Air Traffic to schedule limited elevator shutdown time.**

FLOOR 10
ROOM 1028

1. A containment and negative pressure enclosure system shall be established as described in section 1B.9 Remediation Area. A decontamination unit shall be established as described in section 1B.10 Decontamination Area.
2. Cleanup and removal of moisture and microbiological contaminated gypsum board, shaft liner, and insulation in the DTW ATCT room 1028, in accordance with the guidelines established by the New York City Department of Health Entitled *Guidelines on Assessment and Remediation of Fungi in Indoor Environments* (GARFIE) attached and incorporated herein by reference (see attachment 1).
3. The north wall shaft liner in its entirety shall be HEPA vacuumed and then wet wiped with an approved cleaning solution.
4. Remove and dispose of existing carpet.
5. Remove and replace gypsum board, shaft liner, and insulation totaling approximately 792 square feet:
 - a. The north (elevator shaft) wall, 22' wide for the full height (surface layer, concealed layer and shaft liner).

The removal method and all related work must be in conformance with FAA polices, U.S. Occupational Safety and Health Administration (OSHA) and all State of Michigan regulations.

SECTION 1B - SPECIAL REQUIREMENTS

- 1B.1 **COORDINATION.** All contacts between the contractor and Airway Facilities/Technical Operations shall be coordinated through the Resident Engineer and his/her designated representative.
- 1B.2 **CONTRACTOR'S RESPONSIBILITY.** The Contractor shall perform all work required to give a complete and satisfactory job as required by this Statement of Work. The Contractor shall be responsible for performing this work in accordance with GARFIE. The Contractor shall perform the work per the schedule and sequence identified in the SSOW. The Contractor shall be responsible for all debris generated under this contract at the job site and during transport of microbiological containing or contaminated materials to an approved disposal site.
- 1B.3 **SITE VISIT.** **The quantity of MCM or MCE material to remediate is approximately 500 SF and the quantity of drywall removal is approximately 4300 SF FOR BIDDING PURPOSES ONLY.** The Contractor is responsible for inspecting the work space and field verifying all quantities for: constructing a negative pressure enclosure for each phase of the work, MCM, MCE removal and disposal, work area physical parameters, access limitations, and Government phasing limitations. The Contractor shall be required to work around existing furniture, fixtures

and finishes during the performance of this contract. The site visit shall be scheduled by the Government for interested microbiological remediation Contractors to identify specific work area and phasing requirements. The contractor shall take steps necessary to ascertain the nature of the work, and satisfy themselves to the conditions that can affect the work. No subsequent extras will be allowed due to any claim of lack of knowledge for conditions that can be determined by examining the site. Site visits can be arranged by contacting Facility Manager, Dave Saunders (734) 955-5101, at least 24 hours prior to the planned visit.

- A. Property Damage. The Contractor shall take all precautions to avoid damage to Government property or equipment. Any damage to Government property or equipment by the Contractor shall be repaired by the Contractor to its original state or better condition at no additional expense to the Government.
- B. Working Conditions. Portions of the ATCT will be occupied and Government operations will continue on a normal, temporary, or restricted basis for the duration of the project. The Contractor shall take all precautions to ensure that their operations are conducted in a manner that does not interfere with the normal operations of the surrounding facilities and the safety and health of the occupants or the environment. Contractor's personnel will have limited access to the facility.
- C. Cleanup. Upon completion of the work at the site, all staging and debris from the project shall be removed from the site and disposed of properly. The entire area shall be left clean and acceptable to the Government.
- D. Certifications. The Contractor shall be certified by the Indoor Air Quality Association (IAQA), the Institute of Inspection, Cleaning, and Restoration (IICR), the National Duct Cleaning Association (NADCA) or equivalent.

1B.4. SCHEDULE. See contract documents for duration of contract and notice to proceed.

Working Hours. Due to noise-level and air-quality issues, the work shall be performed during off-peak hours.

The work shall be performed between 11:00 p.m. and 6:00 a.m. Eastern Time, Monday through Friday on Government workdays only, unless arranged at least 48 hours in advance with the FAA Resident Engineer (RE).

1B.5 Pre-Construction Meeting. The Contractor shall attend a mandatory pre-construction meeting before starting work and the Government will schedule the meeting. The contractor shall attend the conference and shall abide by all agreements reached at the conference regarding:

- A. Detailed procedures for administration of the project.
- B. Identity of the Resident Engineer, authorized representative of the Government / Contracting Officer, and the contractor's superintendent(s).
- C. Contractor's telephone number.
- D. Detailed procedures for submittals.
- E. Available storage areas for contractor's materials and equipment.
- F. Compliance with FAA safety practices, general operating procedures and security regulations.
- G. Availability of on site power for use by the contractor as determined by the Resident Engineer.
- H. The FAA Pre-Construction and Maintenance Project Safety and Health Checklist, FAA form 3900-8 and the AGL Construction and Maintenance Project Ventilation and Airborne Contaminants Checklist will be reviewed and filled prior to the start of work.
- I. Contractor shall provide copies of all MSDS sheet for any products and restoration materials to be used.
- J. In addition to the foregoing, other subjects pertinent to the contract may be discussed.

- 1B.6. **TEMPORARY FACILITIES AND STAGING AREA.** The electrical energy and the water consumed shall be provided by the Government at no cost to the Contractor from existing lines and sources located in the ATCT or from services adjacent to the work areas. Contractor's use of utilities shall be coordinated with the Government. Contractor is responsible for ensuring that adequate electrical power and water are available to complete the work. The Contractor will be permitted to use the areas as directed by the Government for staging and storage of materials. The area is restricted to uncontaminated work equipment and supplies. The area shall be left clean and restored to the same condition as when accepted by the Contractor.
- 1B.7 **MEDICAL REQUIREMENTS.** Contractor shall provide medical surveillance and have a written Respiratory Protection program in place as required by OSHA 29 CFR 1910.134 for all personnel engaged in the removal and demolition of MCM and MCE. Respirators and filters provided shall be NIOSH approved and provide the appropriate level of protection.
- 1B.8 **PROTECTIVE CLOTHING.** Contractor shall provide workers and government representatives with sufficient sets of protective full body clothing. Such clothing shall consist of full body coveralls including head covers, foot covers and hand covers. Contractor shall provide additional personal protection safety equipment as required by applicable OSHA safety regulations. Contractor shall ensure that all employees who will conduct mold remediation activities are provided with, fit tested for, and trained in the correct use of personal protection equipment.
- 1B.9 **REMEDIATION AREA.** Contractor shall establish a remediation area and restrict the access to the microbiological work areas during work conducted in the ATCT. Contractor shall establish a roped-off perimeter and provide warning barrier tape and signs outside the perimeter of the negative pressure enclosure system. Contractor shall establish a negative pressure enclosure system by sealing all critical penetrations or openings to the work area with a minimum of two layers of six-mil polyethylene. Negative pressure enclosures shall have a minimum of four air exchanges per hour and shall be maintained and recorded with a magnehelic gauge or equivalent device under a minimum negative pressure differential of -0.02 inches of water relative to adjacent non-work area space. Negative air pressure equipment shall be equipped with a HEPA filter and exhaust shall be discharged outside the building, a minimum of 25 feet from building access points and building make-up air sources, or wherever necessary, negative air pressure equipment shall be equipped with a HEPA filter and exhaust shall be discharged through a second HEPA filter in order to permit recirculation of air inside the building. Personnel shall wear and utilize protective clothing and equipment in the remediation area as specified herein.
- 1B.10 **DECONTAMINATION AREA.** Contractor shall establish a decontamination unit for passage to and from the work area during remediation operations in order to minimize the leakage of mold-contaminated dust to the outside. This unit shall consist of a minimum of two chambers, including a clean room and equipment room separated by airlocks. The airlocks shall be formed by overlapping three sheets of 6-mil polyethylene sheeting at the exit of one room and three sheets at the entrance to the next room, with three feet of space between the barriers. Airlocks shall be constructed to effectively maintain negative pressure while not inhibiting worker egress in an emergency situation.
- 1B.11 **WORKER PROTECTION PROCEDURE.**
- A. Each worker and authorized visitor shall, upon entering the job site, put on appropriate respirator and clean protective clothing, before entering the work area.
 - B. Each worker and authorized visitor shall remove gross contamination from clothing by HEPA vacuuming, prior to leaving the remediation work area. After decontamination of protective clothing, while still wearing the respirator, remove protective clothing and dispose as microbiological waste, as appropriate, in a drum or two layers of 6-mil polyethylene disposal bags.
 - C. Workers shall not eat, drink, smoke, or chew gum or tobacco at the work site. Workers shall be fully protected with respirators and protective clothing immediately prior to the first disturbance of MCM or MCE and until final cleanup is completed.

- 1B.12 AIR MONITORING AND INSPECTION. The Government-retained Industrial Hygienist will determine any requirement for air monitoring, both during the remediation process and/or upon completion of the remediation process. Such area sampling will be conducted using Zefon filters and a high volume sampling pump. Procedural modifications to the decontamination procedures may be necessary at the discretion of the Government-retained Industrial Hygienist. The Government has the right to inspect the remediation work at times to be determined by the Government, but, at a minimum, once upon completed removal of contaminated materials, but before restoration materials are installed.
- 1B.13 FINAL CLEARANCE. Acceptance of work will be dependant upon visual inspection. In areas where the gypsum board removal quantity exceeds 100 square feet, clearance air sampling shall also be conducted. The Contractor shall notify the Government when the microbiological removal is completed for each phase and the Government-retained Industrial Hygienist shall perform a thorough visual inspection of the phase within 24-hours. Clearance air sampling shall be conducted in Rooms 928 and 428. Clearance criteria shall be dependent upon the requirements stipulated in the DTW ATCT Mold Remediation Project Clearance Protocol attached and incorporated herein (See Attachment 2). All remaining rooms shall be clearly solely by visual examination.
- 1B.14 DISPOSAL. All microbiological waste shall be disposed of at a municipal sanitary landfill. Waste bags shall not be overloaded and shall be securely sealed and stored in the designated area until disposal. Label bags, disposal containers, and truck during loading and unloading, in accordance with Federal, State and Local regulations. Contractor is responsible for removal of all materials from the Government's property.
- 1B.15 INGRESS AND EGRESS TO WORK AREA. The Resident Engineer shall direct all ingress and egress to the work area. Security precautions against unauthorized facility entrance will be maintained.
- 1B.16 SECURITY REQUIREMENTS. The Airport Traffic Control Tower (ATCT) facility is a secured facility and access to the interior is restricted to FAA personnel only. Therefore, all work included in this contract shall be coordinated to preclude interference with the operation of the facility. The contractor will coordinate this with the contracting officer through the Resident Engineer. The contractor shall examine the premises and satisfy himself/herself as to the existing conditions under which he/she will be obligated to perform the work included in this contract.
- 1B.17 PARKING OF CONTRACTOR VEHICLES. All personnel will park their vehicles away from the building and all access doors or as authorized by the Resident Engineer. Materials and tools may be off-loaded at the work site by arrangement with the Resident Engineer.
- 1B.18 STORAGE OF MATERIALS. The contractor shall store all materials in a manner to protect them from all elements of the weather. Storage of reasonable quantities of material, supplies, and tools on site is permissible providing the Resident Engineer authorizes the location. The FAA is not responsible for the security of the materials, supplies and tools owned by the contractor.
- 1B.19 COMPLIANCE WITH LOCAL CODES AND OTHER CODES. The contractor shall comply with local and other codes of standard trade practices adopted by these contract documents. Where the requirements of the specifications and drawings exceed those of the local and adapted codes, the contractor shall comply with the requirements of the specifications and drawings.
- 1B.20 CLEANING.
- A. Remediation Area. The contractor shall keep the remediation area in a clean and proper condition. All rubbish and waste resulting from the execution of the work shall be removed at the end of each day or as directed by the Resident Engineer.
 - B. Waste Packing Materials. Immediately after unpacking, all packing material shall be removed from the building and the premises.

- C. Final Cleanup. Upon completion of work and before final inspection, the contractor shall remove his working tools, equipment, debris, rubbish and unused materials from the building site.
- D. Disposal. Disposal of rubbish and debris will be offsite and at no additional cost to the FAA or as directed by the Resident Engineer.

1B.21 NON-INTERFERENCE WITH EXISTING FACILITY OPERATION.

- A. Job Conditions. The access to the facility shall be kept unobstructed at all times. If any interference with the existing facility operation or access seems to be unavoidable, the contractor shall advise the contracting officer through the Resident Engineer 24 hours before such interference. FAA reserves the right to stop work at any time if the operation of this facility is jeopardized by the contractor's work.
- B. Equipment Shutdown. Each ATCT facility maintains air traffic control continuously without shutdown. Various techniques are employed to achieve maximum system availability. Mechanical and electrical systems in direct support of air traffic operation and environmental systems have redundant configurations. Shutdown of equipment shall be scheduled with the Resident Engineer at least 24 hours prior to the control system installer's need. The reliability of mechanical and electrical systems is compromised when redundant equipment is not available. Every effort will be made by the FAA to allow work to be accomplished during the installer's working hours; however, the Resident Engineer will restore equipment to service immediately after this period. FAA personnel shall accomplish equipment shutdown.

1B.22 OTHER CONTRACTS. The Government may undertake other contracts for additional work at or near the site of the work under this contract. The contractor shall fully cooperate with other contractors and with the Government employees and shall adapt scheduling and performing the work under this contract to accommodate the other work. The contractor shall not commit or permit any act that will interfere with performance of work by any other contractor or by Government employees.

1B.23 CONTRACTOR'S LIABILITY. Damage to the existing facility or equipment caused by the contractor shall be immediately reported to the FAA Resident Engineer without delay. The contractor shall be responsible for repairing or having repaired all damaged areas to the facility or equipment directly caused by contractor related work. All repairs shall be accomplished, without delay, at the contractor's expense to the satisfaction of the FAA Resident Engineer.

1B.24 PERMITS. The contractor shall be responsible for obtaining all city, county, etc., permits, if required, to complete the project, at no additional cost to the Government.

1B.25 MATERIAL. All equipment, material, and articles incorporated into the work covered by this contract shall be new and of the most suitable grade for the purpose intended, unless otherwise specifically provided in this contract.

References in the specifications to material, articles, or patented processes by trade name, make, or catalog number, shall be regarded as establishing a standard of quality and shall not be construed as limiting competition. The contractor may, at his option, use any equipment, material, article, or process that, in the judgment of the Resident Engineer, is equal to that named in the specifications, unless otherwise specifically provided in this contract.

- A. Brand Name Items. The use of brand names or equal products in this specification does not constitute a requirement that they are the only materials that meet the specifications in this contract. They are used as an illustration of known acceptable sources or products.

- 1B.26 **WORKMANSHIP.** The contract shall be accomplished by workers experienced in each trade in accordance with the highest standards of the various trades involved. The FAA Resident Engineer must approve all details, to assure a professional and complete project, whether stated in the specifications or not. The Resident Engineer may require, in writing, that the contractor will remove from the work any employee the Resident Engineer deems incompetent, careless, or otherwise objectionable.
- 1B.27 **SUPERINTENDENCE BY THE CONTRACTOR.** At all times during performance of this contract and until the work is completed and accepted, the contractor shall directly superintend the work on site or assign and have on site a competent superintendent who is satisfactory to the Resident Engineer and has authority to act for the contractor.
- 1B.28 **WARRANTIES.** The contractor shall guarantee that all works performed under this contract to be free from defects in all material and workmanship for a period of 12 months from the date of final acceptance by the Government.
- 1B.29 **RESPONSIBILITIES.** If within the warranty period, such parts or work performed under this contract is found to be defective in materials or workmanship, the contractor immediately without any additional cost to the Government shall replace that portion of work.

SECTION 1C - SUBMITTALS

- 1C.1 **INTRODUCTION.** Each product required for use in the contract drawings and specifications must meet the actual minimum needs of the Government as demonstrated in the salient characteristics for that product. If a brand name product is used in the drawings or specifications, it should be regarded as a "known acceptable source". The product used can be identical or equal to the brand name product or known acceptable source in meeting the salient characteristics, but it need not exceed the actual minimum requirements. Any brand name product or known acceptable source mentioned will, however, not be required for use in order to comply with the specification or drawing unless those documents make it clear that the brand name product is required, and substitution is prohibited.
- 1C.2 **REQUIREMENTS.** The Contracting Officer or his/her designee must approve each product that a Contractor wishes to use that is not a known acceptable source, before use. To gain approval, the Contractor must submit documents and/or samples that will demonstrate the product clearly will meet the Government's minimum needs, and demonstrates appropriate salient characteristics. All submittals must be in writing. The Contracting Officer shall have the right to require submittals from the Contractor where the Contractor makes an unsolicited change proposal.
- The information presented in a submittal shall be sufficient to demonstrate that all specification requirements for the subject material, equipment, methods, or plans, are met by the Contractor's proposal.
- 1C.3 **SUBMITTAL REVIEW.** When submitting before the Notice to Proceed date, the Contractor shall send the submittal package(s) directly to the Contracting Officer. When submitting after Contract work has begun, the Contractor shall give submittal packages to the Resident Engineer, who will forward them promptly to the Contracting Officer. In either case, the submittal will return directly from the Contracting Officer to the Contractor, with the Contracting Officer's approval, approval with comments, or disapproval.
- 1C.4 **SUBMITTAL TIME FRAME.** To provide adequate time for document transmission and submittal review, the FAA reserves the right to take ten days to complete a review, transmission date to transmission date. Since this Contract has a short duration, the Contractor is urged to initiate submittals along with his/her bid and to in general to expedite document transmission. The Contracting Officer will expedite reviews and document transmission to the extent that it is feasible.

1C.5 SUBMITTALS

A. The contractor shall submit all the following:

1. Work Plan
2. Safety Program
3. Certificate of training, accreditation, qualification
4. List of Employees
5. Proof of Insurance
6. Material Safety Data Sheets for all chemical products.
7. Respiratory Fit Test and Medical Surveillance for employees scheduled for this project.
8. Negative Air HEPA Filtration Equipment Specification Sheet
9. Proposed Phasing Schedule.

B. All required submittals shall be provided to the Contracting Officer at the following address:

FEDERAL AVIATION ADMINISTRATION
2300 East Devon Ave.
Des Plaines, IL 60018

1C.6 OTHER ITEMS. Any notification to any regulatory agency whether federal, state or local is the responsibility of the Mold abatement contractor. A copy of any notification is to be provided to the RE for record retention.

1C.7 PROCUREMENT BEFORE APPROVAL. The Contractor is advised not to procure any item for which submittal approval is required but not yet granted. If approval is denied, the Contractor will be prevented from installing the disapproved item(s). The Contractor must transmit a new submittal package for the new items replacing the disapproved items, and must procure only approved items. The Contractor shall take responsibility for the delivery and installation of any items installed before submittal approval is granted. The FAA reserves the right to discontinue fieldwork on any item furnished without submittal approval.

1C.8 CONTRACTOR QUALIFICATION REQUIREMENTS. The contractor shall provide all the services, equipment, supplies, materials, and labor required to remediate, remove, replace drywall & insulation, and dispose all waste. The abatement contractor must comply with the following:

- A. All work shall be done under the direct supervision of a professional with experience and training in mold remediation.
- B. The contractor shall coordinate and prepare a schedule to be approved by the Resident Engineer for conducting the remediation at DTW ATCT.
- C. Prior to the scheduled pre-construction meeting the contractor shall provide copies of all MSDS sheets for any chemicals and other products that have been authorized by the FAA that will be brought on site and used during this project.
- D. No chemical cleaners, disinfectants, mold inhibitors, fungicides, encapsulants, spray adhesives, odor masking agents, air fresheners or similar materials are authorized for use during this project and may not be brought onsite. When approved by the FAA prior to use, small quantities of low odor consumer type hand dishwashing detergent may be used when mixed with water for the purpose of wetting cleaning cloths used for damp wiping surfaces.
- E. The surfaces of the room shall be HEPA vacuumed or damp wiped, and then covered prior to the start of any mold remediation work.
- F. All 6-mil polyethylene sheeting is to be fire retardant.
- G. The contractor shall notify the RE **IMMEDIATELY** if any conditions are identified during the remediation, which may require immediate attention to prevent potential exposure to mold at the facility.

- H. Security and insurance requirements: The ATCT's are secured facilities and all personnel entering the facility shall meet all security and insurance requirements for gaining access to the individual facility. Insurance requirements are listed below:

SECTION 1D - ABATEMENT

1D.1 SECURITY.

The DTW ATCT is under security at all times. All critical areas (ATCT tower and base building) are controlled and security must be maintained. The contractor will provide a list of all personnel that will be entering the facility to do abatement work, to the CO/COR/RE.

The abatement Contractor shall maintain a logbook documenting entry into and out of the regulated work area. The Contractor shall not allow unauthorized personnel access to the site. Authorized personnel include the Abatement Contractor and his/her workers, CO and his/her representatives, the Environmental Contractor, representatives of regulatory agencies having jurisdiction over the project, FAA bargaining unit representatives and fire or medical response personnel in the event of emergency. No other person(s) may enter the areas occupied by the contractor or his/her equipment without submitting evidence of completion of required medical examinations and respirator training to the COTR/RE prior to entering the abatement areas.

All facility-specific security procedures will be followed.

1D.2 DRYWALL REMOVAL.

- A. Remove drywall to the extent indicated on the drawings. Drywall shall be cut away through the use of a spiral cutting saw equipped with a close capture exhaust system attached to a HEPA filtered vacuum for dust control. The cutting depth of the spiral saw will be adjusted to a depth slightly less than the thickness of the drywall. Final cutting of the scored drywall will be made with a razor knife to avoid release of dust into the wall cavity and to prevent damage to concealed equipment, or additional layers of wall board that are present. In areas where access restrictions prevent use of the spiral saw, hand saws may be used, but only while a HEPA filtered vacuum is used to capture dust at the point of generation. Reciprocating saws shall not be used.

DIVISION 7 – THERMAL AND MOISTURE PROTECTION
SECTION 7A – BUILDING INSULATION

7A.1 GENERAL.-

A. Scope.- This section includes furnishing and installing the following materials required for the work:

1. Batts or Blankets
2. Plastic Sheet Vapor Retarder
3. Fire-Rated Sealing Putty
4. Fire Stopping

7A.2 APPLICABLE DOCUMENTS.- The following specifications and standards, of the issues currently in force, form a part of this section and are applicable as specified herein:

1. American Society for Testing and Materials Standards (ASTM).-

- C 552 Cellular Glass Thermal Insulation
- C 578 Rigid, Cellular Polystyrene Thermal Insulation
- C 665 Mineral-Fiber Blanket Thermal Insulation for Light Frame Construction and Manufactured Housing.
- E 84 Surface Burning Characteristics of Building Materials

2. Federal Specifications (FS).-

HH-I-1972/1 Insulation Board, Thermal Polyurethane or Polyisocyanurate, Faced with Aluminum Foil on both Sides of the Foam.

3. Underwriter's Laboratories, Inc. (UL) Publication.-

Building Materials Directory

7A.3 MATERIALS.-

A. Factory Mutual Research Corporation (FM) Publication.-

Approval Guide

B. Batts or blankets conforming to ASTM E 84, and ASTM C665.-Type I shall have a flame spread rating of 25 or less without evidence of continued progressive combustion and a smoke developed rating of 50 or less. Unless specified otherwise in the following paragraphs, glass fiber insulation shall be accepted.

Insulation shall be either blanket or batt type in width required to fill the stud spaces. Provide "U" value of .05 for exterior walls and "U" value of .09 for interior partitions where required.

Known acceptable sources:

Boise Cascade Building Products - Insulite Fiberglas Building Insulation.

National Gypsum - Gold Bond Glass Fiber Blankets

Owens-Corning - Fiberglas Building Insulation

Manville - Commercial building insulation

- C. Fire-rated sealing putty.- Furnish and install a pre-mixed and reusable putty for completely filling fire-rated wall and floor openings to prevent the spread of fire, smoke and toxic gases through, cable, pipe and conduit penetrations. Product shall be listed in UL Building Materials Directory.

Known acceptable sources:

The RectoSeal Corp. – Metacaulk 1000

Nelson Electric "Flame Seal"

Or approved equal

- D. Fire-rated caulk.- Furnish and install a pre-mixed caulk for completely filling fire-rated 1/2" wall to floor gap to prevent the spread of fire, smoke and toxic gases. Product shall be listed in UL Building Materials Directory.

Known acceptable sources:

JACO Manufacturing inc. Fire and Draft Sealer™

JACO Manufacturing inc. Firestop Plus™

Or approved equal

- E. Fire Safing.-Furnish and install mineral fiber safing insulation, vapor retarding foil faced, with galvanized steel safing clips.

Known acceptable source:

USG Interiors, Inc. Thermafiber Division.

- F. Fire Blocks.- Fire-stop at cable trays penetration through concrete or CMU wall or slab shall conform to Underwriters Laboratories (UL) Design No. CAJ4035. Fire-stop at cable trays penetration through gypsum wall shall conform with UL Design No. WL4011, unless otherwise indicated on drawings.

Known acceptable source:

Hilti Fire-Stop Systems

7A.4 INSTALLATION.-

- A. Wall insulation.- Use open face batts placed between studs so as to be continuous for full floor-to-floor height unless shown otherwise. Tightly butt insulation at cross joints and against abutting surfaces. Fasten in place as recommended by the manufacturer. Where electric outlets, ducts, pipes, vents or other utility item occur, insulation shall be placed on the cold or weather side of the item. Install plastic sheet vapor barrier to warm side of insulation. Foundation walls and slab perimeter insulation shall be installed as per manufacturer's recommendation.
- B. Foil Faced Rigid Insulation board at Base Building basement and Tower walls.-Install rigid insulation board per "Celotex" specification for cavity wall insulation with 3/4-inch reflective air space and hat shaped metal furring, with 5/8" Type "X" gypsum wallboard thermal barrier.

- C. Vapor barrier.- Install fire retardant reinforced polyethylene sheet vapor barrier to warm side of unfaced batt or rigid insulation. Extend vapor barrier full height from top of concrete floor slab to underside of the floor or roof slab above. Tape joints and around penetrations to provide continuous membrane.
- D. Fire-rated sealing putty.- After floor and wall finishes have been applied and cured, install fire-rated sealing putty in compliance with manufacturer's printed instructions. Provide neat, clean installation flush with finish surfaces. Seal openings around penetrations through fire-rated partitions, walls, floors, and all other locations as required by local code authorities. Provide shelf angles where applicable, to hold fire-rated sealing putty in place.
- E. Fire Safing.-Install along edge of floor slab, and curtain wall glazing panels and all pipe penetrations through the floor slab in conjunction with fire - rated sealing putty and as per manufacturer's recommendations.
- F. Fire Blocks.- Install at cable tray penetrations in accordance with manufacturer's printed recommendations.

7A.5 QUALITY ASSURANCE.-

- A. Submittals.- Submit for all types of installation required manufacturer's literature with samples of proposed fastening methods for approval.
 - 1. Fire-rated sealing putty.- Submit for approval product samples and list of openings to be sealed.
 - 2. Fire Blocks.- Submit for approval product sample and list of openings to be sealed.
- B. Delivery and storage.- Deliver materials to the site in manufacturers unopened original packaging with the manufacturer's name brand clearly visible.

DIVISION 8 – DOORS AND WINDOWS
SECTION 8A – ACCESS DOORS AND FRAMES

8A.1 GENERAL.

A. Scope:

1. Fire rated wall access panels.
2. Related hardware and attachments.

B. System Description

1. Design Requirements:
2. Verification: Obtain specific locations and sizes for required access doors and frames from trades, including mechanical and electrical, requiring access to concealed equipment and indicate on submittal schedule.

C. Submittals

1. Shop Drawings:
 - a. Door and panel units: Show types, elevations, thickness of metals, full size profiles of door members.
 - b. Hardware: Show materials, finishes, locations of fasteners, types of fasteners, locations and types of operating hardware, and details of installation.
 - c. General: Show connections of units and hardware to other Work. Include schedules showing location of each type and size of door and panel units.
 - d. Product Data: Manufacturer's technical data for each type of access door and panel assembly, including setting drawings, templates, fire-resistive characteristics, finish requirements, and details of anchorage devices.
 - e. Include complete schedule, types, locations, construction details, finishes, latching or locking provisions, and other pertinent data.
 - f. Manufacturer's Installation Instructions: Indicate installation requirements and rough-in dimensions.

D. Quality Assurance

1. Single Source Responsibility: Obtain access door and panel units, and frames for entire Project from 1 source and 1 single manufacturer.
2. Fire-Resistance Ratings: Wherever a fire-resistance classification is indicated, provide access door and panel assemblies with panel door, frame, hinge, and latch from manufacturer listed in Underwriter's Laboratories (UL), "Building Materials Directory" for rating shown.
3. Provide 90 minute UL label at 2-hour rated partitions.
4. Size Variations: Obtain Architect's acceptance and approval of manufacturer's standard size units that may vary slightly from sizes indicated on Drawings.
5. Coordination: Provide inserts and anchoring devices that will be built into other Work for installation of access door assemblies. Coordinate delivery with other Work to avoid delay.

E. Delivery, Storage And Handling

1. Package and ship per manufacturer's recommendations.
2. Store per manufacturer's instructions.
3. Store in dry area out of direct sunlight.

F. Warranty

1. Provide manufacturer's written warranty
2. Warrant materials and workmanship against defects after completion and final acceptance of Work.
3. Repair defects, or replace with new materials, faulty materials or workmanship developed during the guarantee period at no expense to Owner.
4. Access Panel Warranty: 1 year from date of Substantial Completion of Project.

8A.2 PRODUCTS

A. Manufacturers

Subject to compliance with requirements, provide products from the following manufacturer or equivalent:

Nystrom Building Products
 1701 Madison Street NE
 Minneapolis, MN 55413-1400
 Toll Free Hotline: 800-547-2635
 Toll Free Fax: 800-317-8770
 Direct Phone: 612-781-7850
 Direct Fax: 612-781-1363
 E-Mail: info@nystrom.com
 Internet: www.nystrom.com

Specifications and Drawings are based on manufacturer's proprietary literature from Nystrom Building Products. Other manufacturers shall comply with minimum levels of material, color selection, and detailing indicated in Specifications or on Drawings.

B. Materials

1. Commercial quality, cold steel sheet with baked on rust inhibitive gray primer.
2. Galvanized, bonderized steel with baked on rust inhibitive gray primer.
3. Type: No. 304 stainless steel with No. 4 satin polish finish.

C. Access Panels

1. Insulated fire rated access panels for walls, Nystrom I series
 - a. Maximum size horizontal applications = 12 inch.
 - b. Maximum size vertical applications: IT= 12 inch.
 - c. Door: Fabricate from 20-gauge cold rolled sheet steel, insulated sandwich type construction.

- d. Frame: Fabricate from 16-gauge cold rolled steel of configuration to suit material application.
- e. IT - All surfaces - 1 inch flange at perimeter.
- f. Hinge: Flush continuous piano type on model IT.
- g. Latching/Locking mechanism: Knurled knob/flush key operated latch bolt - standard.
- h. Finish: Phosphate dipped with factory applied prime coat.
- i. Insulation: 2 inch thick fire rated mineral fiber.
- j. Automatic closure device: Integral automatic spring closure device for each door.
- k. Interior latch release: Mechanism to allow for panel to open from interior side.

D. Fabrication

- 1. Manufacture each access panel assembly as an integral unit ready for installation.
- 2. Welded construction: Furnish with a sufficient quantity of 1/4 inch mounting holes to secure access panels to types of supports indicated.
- 3. Recessed panel: Form face of panel to provide specified recess for application of finish material. Reinforce panel as required to prevent buckling.
- 4. Furnish number of latches required to hold door in flush, smooth plane when closed.

8A.3 EXECUTION

A. Examination

Verify that rough openings for door and frame are correctly sized and located.

B. Preparation

Advise installers of work relating to access panel installation including rough opening dimensions, locations of supports, and anchoring methods. Coordinate delivery with other work to avoid delay.

C. Installation

- 1. Install access door and frame units per manufacturer's written instructions.
- 2. Install frames plumb and level in opening. Secure rigidly in place.
- 3. Position units to provide convenient access to concealed Work requiring access.
- 4. Fire-rated units: Include UL or Warnock-Hersey labels.

D. Adjust And Clean

- 1. Adjust panel after installation for proper operation.
- 2. Remove and replace panels or frames that are warped, bowed, or damaged.

DIVISION 9 - FINISHES
SECTION 9A – GYPSUM BOARD

9A.1 – GENERAL

- A. Related Documents. Drawings and general provisions of the Contract, including General and Supplementary Conditions and Division 1 – General Requirements, apply to this section.
- B. Scope. This section includes, but shall not be limited to, non-load-bearing steel framing members for gypsum board assemblies and gypsum board assemblies attached to steel framing.
- C. References. The publications listed below for a part of this specification to the extent referenced. The publications are referred to in the text by the basic designation only. The edition/revision of the referenced publications shall be the latest date as of the date of the Contract Documents, unless otherwise specified.
 - 1. American Society of Testing and Materials (ASTM)
 - a. ASTM C 36 "Standard Specification for Gypsum Wallboard".
 - b. ASTM C 442 "Standard Specification for Gypsum Backing Board and Coreboard".
 - c. ASTM C 475 "Standard Specification for Joint Compound and Joint Tape for Finishing Gypsum Board".
 - d. ASTM C 630 "Standard Specification for Water-Resistant Gypsum Backing Board".
 - e. ASTM C 840 "Standard Specification for Application and Finishing of Gypsum Board".
 - f. ASTM C 1047 "Standard Specification for Accessories for Gypsum Wallboard and Gypsum Veneer Base".
 - 2. Gypsum Association (GA)
 - a. GA 214 "Recommended Specification: Levels of Gypsum Board Finish".
 - b. GA 216 "Application and Finishing of Gypsum Board".
 - c. GA 505 "Gypsum Board Terminology".
 - d. GA 600 "Fire Resistance Design Manual".
 - 3. Underwriters Laboratories, Inc. (UL)
 - a. UL FRD "Fire Resistance Directory".

C. Assembly Performance Requirements

- 1. Performance Requirements, General: Provide gypsum board systems complying with performance requirements specified, as demonstrated by pre-testing manufacturer's corresponding stock system.
- 2. Fire Resistance Rating: Where indicated, provide materials and construction which are identical to those of assemblies whose fire resistance has been determined per ASTM E 119 by a testing and inspection organization acceptable to authorities having jurisdiction.
 - a. Provide fire resistance-rated assemblies identical to those indicated by reference to file numbers in GA 600 or to design designations in UL FRD or in listings of other testing and inspecting agencies acceptable to authorities having jurisdiction.
- 3. Sound Transmission Characteristics: For gypsum board assemblies indicated to have STC ratings, provide materials and construction identical to those of assemblies whose STC ratings were determined per ASTM E 90 and classified per ASTM E 413 by a qualified independent testing agency. Provide the following minimum ratings for sound transmission class (STC):

- a. STC Rating: As indicated but not less than 35.

A. Submittals

1. General: Submit the following in accordance with Conditions of the Contract and Division 1 – General Requirements.
2. Product Data: Submit product data for each type of product specified including, but not limited to, standard details, specifications, installation instructions, and general manufacturer's recommendation.
3. Shop Drawings: Submit shop drawings of unusual conditions in connection with gypsum board construction not specifically shown in manufacturer's product data. Provide elevations and reflected ceiling plans indicating proposed locations for expansion and control joints.
4. Samples: Submit 12 inch (305 mm) square sample boards showing each trim, reveal, control joint, inside and outside corner condition, and typical taped and floated joint. Show intersections, corners, tees, and splices on each sample.
5. Product Certificates: Submit product certificates signed by manufacturers of gypsum board assembly components certifying that their products comply with specified requirements.
6. Product Test Reports: Submit test reports indicating and interpreting test results relative to compliance of gypsum board assemblies with fire resistance, structural performance, and acoustical performance requirements.
7. Research Reports: Submit research reports or evaluation reports of the model code organization acceptable to authorities having jurisdiction which evidence gypsum board assembly's compliance with requirements and with building code in effect for the Project.

B. Quality Assurance

1. Single Source Responsibility:
 - a. Steel Framing: Obtain steel framing members for gypsum board assemblies from a single manufacturer.
 - b. Panel Products: Obtain each type of gypsum board and other panel products from a single manufacturer.
 - c. Finishing Materials: Obtain finishing materials from wither the same manufacturer that supplies gypsum board and other panel products or from a manufacturer acceptable to gypsum board manufacturer.
2. Field Samples: On actual gypsum board assemblies, prepare field samples of at least 100 square feet (9.3 m²) in surface area for the following applications. Simulate finished lighting conditions for review on in-place unit work.
 - a. Wall surfaces indicated to receive non-textured paint finishes.
 - b. Ceiling surfaces indicated to receive non-textured paint finishes.
3. Pre-Installation Conference: Conduct pre-installation conference at the Project site to comply with requirement of Division 1 – General Requirements.

C. Delivery, Storage, And Handling

1. Deliver materials in original packages, containers, or bundles bearing brand name and identification of manufacturer or supplier.

2. Store materials inside under cover and keep them dry and protected against damage from weather, direct sunlight, surface contamination, corrosion, construction traffic, and other causes. Neatly stack gypsum panels flat to prevent sagging.
3. Handle gypsum board to prevent damage to edges, ends, and surfaces. Do not bend or otherwise damage metal corner beads and trim.

D. Project Conditions

1. Environmental Conditions, General: Establish and maintain environmental conditions for applying and finishing gypsum board to comply with ASTM C 840 and with gypsum board manufacturer's recommendations.
2. Room Temperatures: For attachment of gypsum board to framing, maintain not less than 40° F (4° C). For finishing of gypsum board, maintain not less than 50° F (10° C) for 48 hours prior to application and continuously after until dry. Do not exceed 95° F (35° C) when using temporary heat sources.
3. Ventilation: Ventilate building spaces, as required, for drying joint treatment materials. Avoid drafts during hot dry weather to prevent finishing materials from drying too rapidly.

9A.2 PRODUCTS

A Gypsum Board Products

1. General: Provide gypsum board of types indicated in maximum lengths available to minimize end-to-end butt joints. Strongly recommend the use of paperless gypsum board such as DensArmor Plus or equivalent designed for mold and moisture resistance. Water absorption should be less than 5% by weight. When tested in accordance with ASTM D 3273, the product should show no fungal growth and have a rating of 10.
 - a) Thickness: Provide gypsum board in thickness indicated or, if not otherwise indicated, in either ½ inch (13 mm) or 5/8 inch (16 mm) thickness to comply with ASTM C 840 for application system and support spacing indicated.
2. Gypsum Wallboard: Comply with ASTM C36 and as follows:
 - a) Typed:
 - i. Regular for vertical surfaces, unless otherwise indicated.
 - ii. Type X where required for fire resistive-rated assemblies.
 - iii. Sag-resistant type for ceiling surfaces.
 - b) Edges: Tapered
 - c) Thickness: 5/8 inch (16 mm), unless otherwise indicated.
3. Gypsum Backing Board for Multi-Layer Applications: Comply with ASTM C 442 or, where backing board is not available from manufacturer, gypsum wallboard complying with ASTM C 36, and as follows:
 - a) Type:
 - i. Regular for vertical surfaces, unless otherwise indicated.
 - ii. Type X where indicated or required for fire resistive-rated assemblies.
 - iii. Sag-resistant type for ceiling surfaces, unless otherwise indicated.
 - b) Edges: Manufacturer's standard.
 - c) Thickness: 5/8 inch (16 mm), unless otherwise indicated.
4. Water-resistant Gypsum Backing Board: Comply with ASTM C 630 and as follows:
 - a) Type:

- i. Regular, unless otherwise indicated.
 - ii. Type X where required for fire resistive-rated assemblies.
- b) Thickness: 5/8 inch (16 mm), unless otherwise indicated.

B. Cementitious Backer Units

1. General: Provide cementitious backer units complying with ANSI A118.9, of thickness and width indicated below, and in maximum lengths available to minimize end-to-end butt joints.
 - a. Thickness: 5/8 inch (16 mm), unless otherwise indicated.
 - b. Width: Manufacturer's standard width but not less than 32 inches (813 mm).

C. Joint Treatment Materials

1. General: Provide joint treatment materials complying with ASTM C 475 and the recommendations of both the manufacturers of sheet products and of joint treatment materials for each application indicated.
2. Joint Tape for Gypsum Board: Provide paper reinforcing tape, unless otherwise indicated.
 - a. Use pressure sensitive or staple-attached open weave glass fiber reinforcing tape with compatible joint compound where recommended by manufacturer of gypsum board and joint treatment materials for application indicated.
3. Joint Tape for Cementitious for Backer Units: Provide polymer-coated, open glass fiber mesh.
4. Setting Type Joint Compounds for Gypsum Board: Provide factory-packaged, job-mixed, chemical hardening powder products formulated for uses indicated.
 - a. Where setting type joint compounds are indicated as a taping compound only or for taping and filling only, use formulation that is compatible with other joint compounds applied over it.
 - b. For pre-filling gypsum board joints, use formulation recommended by gypsum board manufacturer for this purpose.
 - c. For filling joints and treating fasteners of water-resistant gypsum backing board behind base for ceramic tile, use formulation recommended by the gypsum board manufacturer for this purpose.
 - d. For topping compound, use sandable formulation.
5. Drying Type Joint Compounds for Gypsum Board: Provide factory-packaged vinyl-based products complying with the following requirements for formulation and intended use.
 - a. Ready-Mixed Formulation: Factory-mixed product.
 - b. Topping Compound: Topping compound formulated for fill (second) and finish (third) coats.
 - c. All-Purpose Compound: All-purpose compound formulated for both taping and topping compounds.
6. Joint Compound for Cementitious Backer Unit: Provide material recommended by cementitious backer unit manufacturer.

D Acoustical Sealant

1. Latex Acoustical Sealant: Provide manufacturer's standard nonsag, paintable, nonstaining latex sealant complying with ASTM C 834 and the following requirements:
 - a. Product is effective in reducing airborne sound transmission through perimeter joints and openings in building construction as demonstrated by testing representative assemblies per ASTM E 90.

- b. Product has flame spread and smoke developed ratings of less than 25 per ASTM E 84.
 - ii. Acoustical Sealant for Concealed Joints: Provide manufacturer's standard nondrying, nonhardening, nonskinning, nonstaining, gunnable, synthetic rubber sealant recommended for sealing interior concealed joints to reduce transmission of airborne sound.

E. Miscellaneous Materials

1. General: Provide auxiliary materials for gypsum board construction that comply with referenced standards and recommendations of gypsum board manufacturer
2. Spot Grout: Comply with ASTM C 475, setting type joint compound recommended for spot grouting hollow metal doorframes.
3. Screws:
 - a. Provide steel drill screws complying with ASTM C 1002 for the following applications:
 - i. Fastening gypsum board to steel members less than 0.03 inch (0.76 mm) thick.
 - ii. Fastening gypsum board to gypsum board.
 - b. Provide steel drill screws complying with ASTM C 954 for fastening gypsum board to steel members from 0.033 inch (0.84 mm) to 0.112 inch (2.84 mm) thick.
 - c. Provide corrosion-resistant coated steel drill screws of size and type recommended by board manufacturer for fastening cementitious backer units.
4. Asphalt-Saturated Organic Felt: Comply with ASTM D 226, Type I (No. 15 asphalt felt), non-perforated.
5. Sound Attenuation Blankets: Provide un-faced mineral fiber blanket insulation produced by combining mineral fibers manufactured from glass or slag with thermosetting resins to comply with ASTM C 665 for Type I (blankets without membrane facing).

9A.3 EXECUTION

A. Examination

1. Examine substrates to which gypsum board assemblies attach or abut, installed hollow metal frames, and structural framing, with the Installer present, for compliance with requirements for installation tolerances and other conditions affecting performance of assemblies specified in this section. Do not proceed with installation until unsatisfactory conditions have been corrected.

B. Preparation

1. Before sprayed-on fireproofing is applied, attach offset anchor plates or ceiling runners (tracks) to surfaces indicated to receive spray-on fireproofing. Where offset anchor plates are required, provide continuous units fastened to building structure not more than 24 inches (610 mm) on center.
2. After sprayed-on fireproofing has been applied, remove only as much sprayed-on fireproofing as needed to complete installation of gypsum board assemblies without reducing thickness of sprayed-on fireproofing below that required to obtain fire resistive rating indicated. Protect remaining sprayed-on fireproofing from damage.

C. Applying And Finishing Gypsum Board, General

1. Install and finish gypsum panels to comply with ASTM C 840 and GA 216.
2. Install sound attenuation blankets where indicated prior to installing gypsum panels unless blankets are readily installed after panels have been installed on one side.
3. Install wall/partition board panels to minimize the number of abutting end joints or avoid them entirely. Stagger abutting end joints not less than one framing member in alternate courses of board. At stairwells and other high walls, install panels horizontally with end abutting joints over studs and staggered.
4. Install gypsum panels with face side out. Do not install imperfect, damaged, or damp panels. Butt panels together for a light contact at edges and ends with not more than 1/16 inch (1/6 mm) of open space between panels. Do not force into place.
5. Locate both edge or end joints over supports, except in ceiling applications where intermediate supports or gypsum board back blocking is provided behind end joints. Position adjoining panels so that tapered edges abut tapered edges, and field-cut edges abut field-cut edges and ends. Do not place tapered edges against cut edged or ends. Stagger vertical joints over different studs on opposite sides of partitions. Avoid joints at corners of framed openings where possible.
6. Attach gypsum panels to steel studs so that the leading edge or end of each panel is attached to open (unsupported) edges of stud flanges first.
7. Attach gypsum panels to framing provided at openings and cutouts.
8. Spot grout hollow metal door frames for solid core wood doors, hollow metal doors, and doors over 32 inches (813 mm) wide. Apply spot grout at each jamb anchor clip and immediately insert gypsum panels into frames.
9. Form control joints and expansion joints at locations indicated and as detailed, with space between edges of adjoining gypsum panels, as well as supporting framing behind gypsum panels.
10. Cover both faces of steel stud partition framing with gypsum panels in concealed spaces (above ceilings, etc.) except in chase walls that are braced internally.
 - a. Except where concealed application is indicated or required for sound, fire, air, or smoke ratings, coverage may be accomplished with scraps of not less than 8 square feet (0.74m²) in area.
 - b. Fit gypsum panels around ducts, pipes, and conduits.
 - c. Where partitions intersect structural members projecting below underside of floor/roof slabs and decks cut gypsum panels to fit profile formed by structural members. Allow 1/4 inch (6 mm) to 1/2 inch (13 mm) wide joints to install sealant.
 - d. There shall be a 3/8" to 1/2" gap between the bottom of the gypsum board and the concrete deck. The gap shall be filled with a 2-hr fire-rated caulk.
11. Isolate perimeter of non-load-bearing gypsum board partitions a structural abutment, except floors, as detailed. Provide 1/4 inch (6 mm) to 1/2 inch (13 mm) wide spaces at these locations and trim edges with U-bead edge trim where edges of gypsum panels are exposed. Seal joints between edges and abutting structural surfaces with acoustical sealant.
12. Where STC-rated gypsum board assemblies are indicated, seal construction at perimeters, behind control and expansion joints, openings, and penetrations with a continuous bead of acoustical sealant including a bead at both faces of the partitions. Comply with ASTM C 919 and manufacturer's recommendations for location of edge trim

and closing off sound flanking paths around or through gypsum board assemblies, including sealing partitions above acoustical ceilings.

13. Space fasteners in gypsum panels according to referenced gypsum board application and finishing standard and manufacturer's recommendations.

D. Gypsum Board Application Methods

1. Single-Layer Application: Install gypsum wallboard panels as follows:
 - a. On partitions/walls, apply gypsum panels horizontally (perpendicular to framing), unless parallel application is required for fire resistive-rated assemblies. Use maximum length panels to minimize end joints.
2. Double-Layer Application: Install gypsum backing-board for base layers and gypsum wallboard for face layers.
 - a. On partitions/walls, apply base layers and face layers vertically (parallel to framing) with joints of base layers located over stud or furring member and face layer joints offset at least one stud or furring member with base layer joints. Stagger joints on opposite sides of partitions.
3. Single-Layer Fastening Methods: Apply gypsum panels to supports with screws.
4. Double-Layer Fastening Methods: Apply base layer of gypsum panels and face layer to base layer as follows:
 - a. Fasten both base layers and face layers separately to supports with screws.

E. Finishing Gypsum Board Assemblies

1. Apply joint treatment at gypsum board joints (both directions); flanges of corner bead, edge trim, and control joints; penetrations; and fastener heads, surface defects, and elsewhere as required to prepare gypsum board surfaces for decoration and levels of gypsum board finish indicated.
2. Pre-fill open joints, rounded or beveled edges, and damaged areas using setting type joint compound.
3. Apply joint tape over gypsum board joints except those with trim accessories having concealed face flanges not requiring taping to prevent cracks from developing in joint treatment at flange edges.
4. Provide the following levels of gypsum board finish per GA 214.
 - a. Level 1 for ceiling plenum areas, concealed areas, and where indicated, unless a higher level of finish is required for fire resistive rated assemblies and sound-rated assemblies.
 - b. Level 2 where water-resistant gypsum backing board panels from substrates for tile, and where indicated.
 - c. Level 4 for gypsum board surfaces indicated to receive wall coverings.
 - d. Level 5 for gypsum board surfaces indicated to receive gloss and semi-gloss enamels, non-textured flat paints, and where indicated.
5. For Level 4 gypsum board finish, embed tape in finishing compounds plus two separate coats applied over joints, angles, fastener heads, and trim accessories using the following combination of joint compounds (not including pre-fill), and sand between coats and after last coat:
 - a. Embedding and First Coat: Setting type joint compound.
 - b. Fill (second) Coat: Setting type joint compound.

c. Finish (Third) Coat: Ready-mixed, drying type, all purpose or topping compound.

6. Where Level 5 gypsum board finish is indicated, apply joint compound combination specified for Level 4 plus a thin, uniform skim coat of joint compound over entire surface. Use joint compound specified for the finish (third coat) or a product specially formulated for this purpose and acceptable to gypsum board manufacturer. Produce surfaces free of tool marks and ridges ready for decoration of type indicated.
7. Where Level 2 gypsum board finish is indicated, apply joint compound specified for first coat in addition to embedding coat.
8. Where Level 1 gypsum board finish is indicated, apply joint compound specified for embedding coat.
9. Finish water-resistant gypsum backing-board forming base for ceramic tile to comply with ASTM C 840 and board manufacturer's directions for treatment of joint behind tile.
10. Finish cementitious backer units to comply with unit manufacturer's directions.

F. Cleaning And Protection

1. Promptly remove any residual joint compound from adjacent surfaces.
2. Provide final protection and maintain conditions, in a manner suitable to the Installer that shall ensure gypsum board assemblies shall remain without damage or deterioration at time of Substantial Completion.

SECTION 9B – PAINTING

9B.1 GENERAL.-

- A. Scope.- Furnish materials and application labor necessary to provide paint and transparent finishes on visible new exterior and interior materials and surfaces not noted or specified to be delivered with factory or shop applied finish, not specifically noted or specified as requiring no paint or transparent finish, and not specified to be finished in another section. Also finish those concealed surfaces so specified. In addition, refinish existing painted and transparent finish surfaces as indicated on the drawings.
- B. General.- Carefully examine each specification section to determine exact extent of priming and finishes that will be provided under other Divisions. Include in the work of this Section all other priming and finishing work.
 - 1. Preparation of surfaces to be finished.- Executed under various sections (examine for extent).

9B.2 APPLICABLE DOCUMENTS.- The following specifications and standards of the issues currently in force, form a part of this section, and are applicable as specified herein:

- A. American Society for Testing and materials (ASTM) Publications.-
 - D 362 Industrial Grade Toluene
- B. Structural Steel Paint Council (SSPC). – Surface Preparation

9C.3 MATERIALS.-

- A. General.- The materials listed below are as noted for reference only. These products have been chosen as the basis of the specification because they represent the required quality, reputation, completeness of product line, formulated color range, and established finish systems. Equal products of a manufacturer listed below may be submitted for approval by written list showing a product-by-product comparison with the specified products. The submission shall include a label from the container of each proposed product and a breakdown of the composition of each product. "Professional," "Maintenance" or "Painters" line products will not be acceptable in lieu of top quality retail line products unless the submission is accompanied by a notarized statement from the top official of the manufacturing firm stating that such products equal or exceed the durability, color retention and washability of the firm's top quality retail line. When standard color substitutes are proposed, the request must be accompanied by samples to demonstrate their color match. When special color substitutes are proposed, their appearance, and color match may be evidenced by an official written statement from the manufacturer that satisfactory colors will be delivered based on samples which will be submitted sufficiently in advance of delivery to permit resubmittal until appearance and color match are approved. Mark each sample so as to identify the original selection for which it is being proposed as a substitute. Insofar as possible, painting and finishing materials shall be of one brand.

| | |
|---|-------|
| 1. Known Acceptable Sources: | |
| Zinsser Co. Inc. – Perma-White | White |
| VALPAC Inc – Valprene VI 250 | White |
| Fiberlock Technologies, Inc. –Mildew Pro™ | White |
| Sentinel Products, Inc. -247 | White |

Manufacturer shall certify that colors selected may be re-ordered and obtained in local area, regardless of quality, for a period of not less than 5 years at not more than normal retail price for his products.

2. Workmanship requirements.-
3. Application.- Skilled mechanics shall apply these materials. Execute this work in accordance with best practices recognized for the class of work and grade, type, and kinds of materials specified.
4. Drying.- Do not apply a succeeding coat until preceding coat is dry and hard.
5. Paint.- Use without thinning or adulterating, unless specified otherwise by the manufacturer.
6. Sanding.- Sand each undercoat on interior wood or metal finishes thoroughly and uniformly with No. 80 sandpaper.
7. Brushes.- Lay on brush applied coat so as not to show brush marks.
8. Rollers.- When paint is applied by roller the surface shall be double rolled for each coat by cross-rolling in a 90 degree pattern.
9. Paint film thickness.- Not less than two nor more than 2-1/2 wet mils per coat.

B. Preparation Of Surfaces.-

1. General.- Complete the work required in the following subparagraphs before applying any of the coats specified under finish requirements. Surfaces shall be clean, smooth, and dry at the time of painting. Do not apply paint or transparent finishes under conditions of weather or temperature unsuitable for executing a first-class job. When surfaces are unsuitable for the application of acceptable finishes submit notification of this fact in sufficient time for conditions to be corrected. Start of work implies acceptance of these surfaces and later claims of defects in such work shall in no way change the requirements of this Specification for acceptable work.
2. Gypsum board.- Remove all foreign matter. File all pits flush and smooth with spackle.
3. Colors.- WHITE
 - a. General.- Colors as shown on the drawings shall be considered final, but the right is reserved to vary the value and intensity of any color before application of the final coat. Therefore, no final work shall be done until the base coats have been inspected and approved by the Contracting Officer's Representative. Base coats shall be tinted the same as finish colors, but each coat shall be different in value. Generally, the final coat shall match the color selected, the next-to-last coat shall be lightened by adding 25 percent white and the second-to-last coat shall be lightened by adding 50 percent white. Additional base coats shall be applied untinted.
 - b. Schedule.- Colors for surfaces required to be painted are scheduled on the drawings. If a selection for any such surface has been omitted, request these selections in sufficient time to permit review by the Contracting Officer's Representative and revision of the selection when necessary. The colors are to be determined.
 - c. Selection and mixing.- Selected colors are from the Sherwin Williams standard color system, unless otherwise noted on drawings. If another manufacturer's paint is approved for use, these colors shall be matched exactly. Colors, regardless of quantity, shall be mixed by the manufacturer, using equipment and methods that provide scientifically accurate proportioning of pigments. No colors shall be mixed on the job.

C. Finish Systems.-

1. **General.-** New surfaces - The following coats are required in addition to any shop-applied coats or preparatory work required above or in other Sections. Paint and stain shall be of selected approved colors. Paint finish on specific surfaces shall have surface sheen as scheduled or, where not scheduled, as directed. Select hardwood and hardwood veneer (except hardwood edging of painted shelves, etc.) shall receive transparent finish except where specifically shown to receive another finish.
2. **Coverage.-** The number of coats required under Finishes shall be considered as minimum only and additional coats shall be provided where necessary to achieve full coverage of the surface. Some accent colors may require an additional base coat of paint in white color to achieve full coverage.
3. **Application.-** Except where otherwise specified or approved, apply finishes by the following methods:
 - a. Walls - Brush or roller.
4. **Interior finishes.-**
 - a. Gypsum board.-

| | |
|--------------|--|
| Paint finish | -Semi-gloss |
| Preparation | -Texture mixed with water and rolled on to match approved sample |
| First coat | -Latex Wall Primer |
| Second coat | -Alkyd |

9B.5 **QUALITY ASSURANCE.-**

- A. **Special Guarantee.-** Duration two years.
- B. **Defects.-** This work shall remain in first-class condition as determined by the Contracting Officer's Representative's observation. Failure of work will necessitate repainting of similar surfaces within the area involved.
- C. **Submittals.-** Conform to procedures specified and the requirements below.

Samples - The following submissions may be required.

Paint - Each color and sheen on 12 x 12 inch white cardboard panels.

A representative area of each type surface may be required to be finished on the project for approval. Such approved surfaces will be the standard for like surfaces through the job.
- D. **Omissions.-** The omission of Specifications for a particular finish system does not determine that such finish is not required unless the project does not contain material normally requiring such finish or unless such material is specifically noted or specified as not requiring finish. Submit notice of such omissions during bidding. Failure to do so shall not relieve the Contractor from the responsibility for providing a first-class finish, using an approved system, on all materials and surfaces not specifically exempted.
- E. **Coordination Of Materials.-** Wherever the required shop-applied prime coats are not compatible with the specified finish system, the Contractor shall submit notice and such condition shall be rectified immediately as directed by the Contracting Officer's Representative.

- F. **Relation With Other Trades.**- Where painting is required behind items of equipment, the installing trade is to remove such work temporarily and reconnect them after completion of painting. Notify such trades in sufficient time to permit proper coordination of the work.
- G. **Containers And Labels.**- Materials specified or approved as to manufacturer, brand, and quality must be delivered in unbroken original packages or containers. Such packages or containers must bear brand and manufacturer's name and, where special directions are given, apply materials strictly in accordance with same.
- H. **Schedule Of Finishes.**- After receiving approval of proposed finish products, and before starting work, submit in triplicate a list showing the manufacturer's name and product used on each different surface. This schedule will be used by the Owner as a permanent record.
- I. **Protections.**-
- a. **Other work.**- Protect work of other trades against damage or injury. Work damaged as a result of execution of painting and finishing work shall be satisfactorily repaired or, if it cannot be properly repaired, it shall be replaced with new work. During painting operations, mask finish hardware that is not required to be painted.
 - b. **Work space.**- Any space used for mixing or storing materials for the work of this Section shall be carefully protected from damage, staining, etc., and shall be left in first-class condition.
 - c. **Concrete floors.**- Where concrete floors are scheduled to be left visible, they shall be carefully covered and protected from paint spots, spills, etc. Any paint on such floors must be completely removed.
- J. **Clean-Up.**- Upon completion of this work, remove paint from other finished or prefinished surfaces such as transparent finish wood, ceiling grid, etc., and from unfinished surfaces such as tile, glass, aluminum, hardware, etc. Remove rubbish and accumulated materials connected with this work from the premises.

ATTACHMENT 1

**Guidelines on Assessment and Remediation of
Fungi in Indoor Environments**

Go Back to DOHMH Page

Fungi in Indoor Environments : Environmental & Occupational Disease Epidemiology : NYC DOHMH

EODE

Guidelines on Assessment and Remediation of Fungi in Indoor Environments

- Executive Summary
- Introduction
- Health Issues
- Environmental Assessment
- Remediation
- Hazard Communication
- Conclusion
- Notes and References
- Acknowledgments

Executive Summary

On May 7, 1993, the New York City Department of Health (DOH), the New York City Human Resources Administration (HRA), and the Mt. Sinai Occupational Health Clinic convened an expert panel on *Stachybotrys atra* in Indoor Environments. The purpose of the panel was to develop policies for medical and environmental evaluation and intervention to address *Stachybotrys atra* (now known as *Stachybotrys chartarum* (SC)) contamination. The original guidelines were developed because of mold growth problems in several New York City buildings in the early 1990's. This document revises and expands the original guidelines to include all fungi (mold). It is based both on a review of the literature regarding fungi and on comments obtained by a review panel consisting of experts in the fields of microbiology and health sciences. It is intended for use by building engineers and management, but is available for general distribution to anyone concerned about fungal contamination, such as environmental consultants, health professionals, or the general public.

We are expanding the guidelines to be inclusive of all fungi for several reasons:

- Many fungi (e.g., species of *Aspergillus*, *Penicillium*, *Fusarium*, *Trichoderma*, and *Memnoniella*) in addition to SC can produce potent mycotoxins, some of which are identical to compounds produced by SC. Mycotoxins are fungal metabolites that have been identified as toxic agents. For this reason, SC cannot be treated as uniquely toxic in indoor environments.
- People performing renovations/cleaning of widespread fungal contamination may be at risk for developing Organic Dust Toxic Syndrome (ODTS) or Hypersensitivity Pneumonitis (HP). ODTS may occur after a *single heavy* exposure to dust contaminated with fungi and produces flu-like symptoms. It differs from HP in that it is not an immune-mediated disease and does not require repeated exposures to the same causative agent. A variety of biological agents may cause ODTS including common species of fungi. HP may occur after repeated exposures to an allergen and can result in permanent lung damage.
- Fungi can cause allergic reactions. The most common symptoms are runny nose, eye irritation, cough, congestion, and aggravation of asthma.

Fungi are present almost everywhere in indoor and outdoor environments. The most common symptoms of fungal exposure are runny nose, eye irritation, cough, congestion, and aggravation of asthma. Although there is evidence documenting severe health effects of fungi in humans, most of this evidence is derived from ingestion of contaminated foods (i.e., grain and peanut products) or occupational exposures in agricultural settings where inhalation exposures were very high. With the possible exception of remediation to very heavily contaminated indoor environments, such high-level exposures are not expected to occur while performing remedial work.

There have been reports linking health effects in office workers to offices contaminated with moldy surfaces and in residents

of homes contaminated with fungal growth. Symptoms, such as fatigue, respiratory ailments, and eye irritation were typically observed in these cases. Some studies have suggested an association between SC and pulmonary hemorrhage/hemosiderosis in infants, generally those less than six months old. Pulmonary hemosiderosis is an uncommon condition that results from bleeding in the lungs. The cause of this condition is unknown, but may result from a combination of environmental contaminants and conditions (e.g., smoking, fungal contaminants and other bioaerosols, and water-damaged homes), and currently its association with SC is unproven.

The focus of this guidance document addresses mold contamination of building components (walls, ventilation systems, support beams, etc.) that are chronically moist or water damaged. Occupants should address common household sources of mold, such as mold found in bathroom tubs or between tiles with household cleaners. Moldy food (e.g., breads, fruits, etc.) should be discarded.

Building materials supporting fungal growth must be remediated *as rapidly as possible* in order to ensure a healthy environment. Repair of the defects that led to water accumulation (or elevated humidity) should be conducted in conjunction with or prior to fungal remediation. Specific methods of assessing and remediating fungal contamination should be based on the extent of visible contamination and underlying damage. The simplest and most expedient remediation that is reasonable, and properly and safely removes fungal contamination, should be used. Remediation and assessment methods are described in this document.

The use of respiratory protection, gloves, and eye protection is recommended. Extensive contamination, particularly if heating, ventilating, air conditioning (HVAC) systems or large occupied spaces are involved, should be assessed by an experienced health and safety professional and remediated by personnel with training and experience handling environmentally contaminated materials. Lesser areas of contamination can usually be assessed and remediated by building maintenance personnel. In order to prevent contamination from recurring, underlying defects causing moisture buildup and water damage must be addressed. Effective communication with building occupants is an essential component of all remedial efforts.

Fungi in buildings may cause or exacerbate symptoms of allergies (such as wheezing, chest tightness, shortness of breath, nasal congestion, and eye irritation), especially in persons who have a history of allergic diseases (such as asthma and rhinitis). Individuals with persistent health problems that appear to be related to fungi or other bioaerosol exposure should see their physicians for a referral to practitioners who are trained in occupational/environmental medicine or related specialties and are knowledgeable about these types of exposures. Decisions about removing individuals from an affected area must be based on the results of such medical evaluation, and be made on a case-by-case basis. Except in cases of widespread fungal contamination that are linked to illnesses throughout a building, building-wide evacuation is not indicated.

In summary, prompt remediation of contaminated material and infrastructure repair is the primary response to fungal contamination in buildings. Emphasis should be placed on preventing contamination through proper building and HVAC system maintenance and prompt repair of water damage.

This document is not a legal mandate and should be used as a guideline. Currently there are no United States Federal, New York State, or New York City regulations for evaluating potential health effects of fungal contamination and remediation. These guidelines are subject to change as more information regarding fungal contaminants becomes available.

top of page

Introduction

On May 7, 1993, the New York City Department of Health (DOH), the New York City Human Resources Administration (HRA), and the Mt. Sinai Occupational Health Clinic convened an expert panel on *Stachybotrys atra* in Indoor Environments. The purpose of the panel was to develop policies for medical and environmental evaluation and intervention to address *Stachybotrys atra* (now known as *Stachybotrys chartarum* (SC)) contamination. The original guidelines were developed because of mold growth problems in several New York City buildings in the early 1990's. This document revises and expands the original guidelines to include all fungi (mold). It is based both on a review of the literature regarding fungi and on comments obtained by a review panel consisting of experts in the fields of microbiology and health sciences. It is intended for use by building engineers and management, but is available for general distribution to anyone concerned about fungal contamination, such as environmental consultants, health professionals, or the general public.

This document contains a discussion of potential health effects; medical evaluations; environmental assessments; protocols for remediation; and a discussion of risk communication strategy. The guidelines are divided into four sections:

1. Health Issues; 2. Environmental Assessment; 3. Remediation; and 4. Hazard Communication.

We are expanding the guidelines to be inclusive of all fungi for several reasons:

- Many fungi (e.g., species of *Aspergillus*, *Penicillium*, *Fusarium*, *Trichoderma*, and *Memnoniella*) in addition to SC can produce potent mycotoxins, some of which are identical to compounds produced by SC.^{1, 2, 3, 4} Mycotoxins are fungal metabolites that have been identified as toxic agents. For this reason, SC cannot be treated as uniquely toxic in indoor environments.
- People performing renovations/cleaning of widespread fungal contamination may be at risk for developing Organic Dust Toxic Syndrome (ODTS) or Hypersensitivity Pneumonitis (HP). ODTS may occur after a *single heavy* exposure to dust contaminated with fungi and produces flu-like symptoms. It differs from HP in that it is not an immune-mediated disease and does not require repeated exposures to the same causative agent. A variety of biological agents may cause ODTS including common species of fungi. HP may occur after repeated exposures to an allergen and can result in permanent lung damage.^{5, 6, 7, 8, 9, 10}
- Fungi can cause allergic reactions. The most common symptoms are runny nose, eye irritation, cough, congestion, and aggravation of asthma.^{11, 12}

Fungi are present almost everywhere in indoor and outdoor environments. The most common symptoms of fungal exposure are runny nose, eye irritation, cough, congestion, and aggravation of asthma. Although there is evidence documenting severe health effects of fungi in humans, most of this evidence is derived from ingestion of contaminated foods (i.e., grain and peanut products) or occupational exposures in agricultural settings where inhalation exposures were very high.^{13, 14} With the possible exception of remediation to very heavily contaminated indoor environments, such high level exposures are not expected to occur while performing remedial work.¹⁵

There have been reports linking health effects in office workers to offices contaminated with moldy surfaces and in residents of homes contaminated with fungal growth.^{12, 16, 17, 18, 19, 20} Symptoms, such as fatigue, respiratory ailments, and eye irritation were typically observed in these cases.

Some studies have suggested an association between SC and pulmonary hemorrhage/hemosiderosis in infants, generally those less than six months old. Pulmonary hemosiderosis is an uncommon condition that results from bleeding in the lungs. The cause of this condition is unknown, but may result from a combination of environmental contaminants and conditions (e.g., smoking, other microbial contaminants, and water-damaged homes), and currently its association with SC is unproven.^{21, 22, 23}

The focus of this guidance document addresses mold contamination of building components (walls, ventilation systems, support beams, etc.) that are chronically moist or water damaged. Occupants should address common household sources of mold, such as mold found in bathroom tubs or between tiles with household cleaners. Moldy food (e.g., breads, fruits, etc.) should be discarded.

This document is not a legal mandate and should be used as a guideline. Currently there are no United States Federal, New York State, or New York City regulations for evaluating potential health effects of fungal contamination and remediation. These guidelines are subject to change as more information regarding fungal contaminants becomes available.

top of page

1. Health Issues

1.1 Health Effects

Inhalation of fungal spores, fragments (parts), or metabolites (e.g., mycotoxins and volatile organic compounds) from a wide variety of fungi may lead to or exacerbate immunologic (allergic) reactions, cause toxic effects, or cause infections.^{11, 12, 24}



There are only a limited number of documented cases of health problems from indoor exposure to fungi. The intensity of exposure and health effects seen in studies of fungal exposure in the indoor environment was typically much less severe than those that were experienced by agricultural workers but were of a long-term duration.^{5-10, 12, 14, 16-20, 25-27} Illnesses can result from both high level, short-term exposures and lower level, long-term exposures. The most common symptoms reported from exposures in indoor environments are runny nose, eye irritation, cough, congestion, aggravation of asthma, headache, and fatigue.^{11, 12, 16-20}

The presence of fungi on building materials as identified by a visual assessment or by bulk/surface sampling results does not necessitate that people will be exposed or exhibit health effects. In order for humans to be exposed indoors, fungal spores, fragments, or metabolites must be released into the air and inhaled, physically contacted (dermal exposure), or ingested. Whether or not symptoms develop in people exposed to fungi depends on the nature of the fungal material (e.g., allergenic, toxic, or infectious), the amount of exposure, and the susceptibility of exposed persons. Susceptibility varies with the genetic predisposition (e.g., allergic reactions do not always occur in all individuals), age, state of health, and concurrent exposures. For these reasons, and because measurements of exposure are not standardized and biological markers of exposure to fungi are largely unknown, it is not possible to determine "safe" or "unsafe" levels of exposure for people in general.

1.1.1 Immunological Effects

Immunological reactions include asthma, HP, and allergic rhinitis. Contact with fungi may also lead to dermatitis. It is thought that these conditions are caused by an immune response to fungal agents. The most common symptoms associated with allergic reactions are runny nose, eye irritation, cough, congestion, and aggravation of asthma.^{11, 12} HP may occur after repeated exposures to an allergen and can result in permanent lung damage. HP has typically been associated with repeated heavy exposures in agricultural settings but has also been reported in office settings.^{25, 26, 27} Exposure to fungi through renovation work may also lead to initiation or exacerbation of allergic or respiratory symptoms.

1.1.2 Toxic Effects



A wide variety of symptoms have been attributed to the toxic effects of fungi. Symptoms, such as fatigue, nausea, and headaches, and respiratory and eye irritation have been reported. Some of the symptoms related to fungal exposure are non-specific, such as discomfort, inability to concentrate, and fatigue.^{11, 12, 16-20} Severe illnesses such as ODS and pulmonary hemosiderosis have also been attributed to fungal exposures.^{5-10, 21, 22}

ODS describes the abrupt onset of fever, flu-like symptoms, and respiratory symptoms in the hours following a *single, heavy* exposure to dust containing organic material including fungi. It differs from HP in that it is not an immune-mediated disease and does not require repeated exposures to the same causative agent. ODS may be caused by a variety of biological agents including common species of fungi (e.g., species of *Aspergillus* and *Penicillium*). ODS has been documented in farm workers handling contaminated material but is also of concern to workers performing renovation work on building materials contaminated with fungi.⁵⁻¹⁰

Some studies have suggested an association between SC and pulmonary hemorrhage/hemosiderosis in infants, generally those less than six months old. Pulmonary hemosiderosis is an uncommon condition that results from bleeding in the lungs. The cause of this condition is unknown, but may result from a combination of environmental contaminants and conditions (e.g., smoking, fungal contaminants and other bioaerosols, and water-damaged homes), and currently its association with SC is unproven.^{21, 22, 23}

1.1.3 Infectious Disease

Only a small group of fungi have been associated with infectious disease. Aspergillosis is an infectious disease that can occur in immunosuppressed persons. Health effects in this population can be severe. Several species of *Aspergillus* are known to cause aspergillosis. The most common is *Aspergillus fumigatus*. Exposure to this common mold, even to high concentrations, is unlikely to cause infection in a healthy person.^{11, 24}

Exposure to fungi associated with bird and bat droppings (e.g., *Histoplasma capsulatum* and *Cryptococcus neoformans*) can lead to health effects, usually transient flu-like illnesses, in healthy individuals. Severe health effects are primarily encountered in immunocompromised persons.^{24, 28, 29}



1.2 Medical Evaluation

Individuals with persistent health problems that appear to be related to fungi or other bioaerosol exposure should see their physicians for a referral to practitioners who are trained in occupational/environmental medicine or related specialties and are knowledgeable about these types of exposures. Infants (less than 12 months old) who are experiencing non-traumatic nosebleeds or are residing in dwellings with damp or moldy conditions and are experiencing breathing difficulties should receive a medical evaluation to screen for alveolar hemorrhage. Following this evaluation, infants who are suspected of having alveolar hemorrhaging should be referred to a pediatric pulmonologist. Infants diagnosed with pulmonary hemosiderosis and/or pulmonary hemorrhaging should not be returned to dwellings until remediation and air testing are completed.

Clinical tests that can determine the source, place, or time of exposure to fungi or their products are not currently available. Antibodies developed by exposed persons to fungal agents can only document that exposure has occurred. Since exposure to fungi routinely occurs in both outdoor and indoor environments this information is of limited value.

1.3 Medical Relocation

Infants (less than 12 months old), persons recovering from recent surgery, or people with immune suppression, asthma, hypersensitivity pneumonitis, severe allergies, sinusitis, or other chronic inflammatory lung diseases may be at greater risk for developing health problems associated with certain fungi. Such persons should be removed from the affected area during remediation (see Section 3, Remediation). Persons diagnosed with fungal related diseases should not be returned to the affected areas until remediation and air testing are completed.

Except in cases of widespread fungal contamination that are linked to illnesses throughout a building, a building-wide evacuation is not indicated. A trained occupational/environmental health practitioner should base decisions about medical removals in the occupational setting on the results of a clinical assessment.

top of page

2. Environmental Assessment

The presence of mold, water damage, or musty odors should be addressed immediately. In all instances, any source(s) of water must be stopped and the extent of water damaged determined. Water damaged materials should be dried and repaired. Mold damaged materials should be remediated in accordance with this document (see Section 3, Remediation).

2.1 Visual Inspection

A visual inspection is the most important initial step in identifying a possible contamination problem. The extent of any water damage and mold growth should be visually assessed. This assessment is important in determining remedial strategies. Ventilation systems should also be visually checked, particularly for damp filters but also for damp conditions elsewhere in the system and overall cleanliness. Ceiling tiles, gypsum wallboard (sheetrock), cardboard, paper, and other cellulosic surfaces should be given careful attention during a visual inspection. The use of equipment such as a boroscope, to view spaces in ductwork or behind walls, or a moisture meter, to detect moisture in building materials, may be helpful in identifying hidden sources of fungal growth and the extent of water damage.

2.2 Bulk/Surface Sampling

- a. Bulk or surface sampling is not required to undertake a remediation. Remediation (as described in Section 3, Remediation) of visually identified fungal contamination should proceed without further evaluation.
- b. Bulk or surface samples may need to be collected to identify specific fungal contaminants as part of a medical evaluation if occupants are experiencing symptoms which may be related to fungal exposure or to identify the presence or absence of mold if a visual inspection is equivocal (e.g., discoloration, and staining).
- c. An individual trained in appropriate sampling methodology should perform bulk or surface sampling: Bulk samples are usually collected from visibly moldy surfaces by scraping or cutting materials with a clean tool into a clean plastic bag. Surface samples are usually collected by wiping a measured area with a sterile swab or by stripping the suspect surface with clear tape. Surface sampling is less destructive than bulk sampling. Other sampling methods may also be available. A laboratory specializing in mycology should be consulted for specific sampling and delivery

instructions.

2.3 Air Monitoring

- a. Air sampling for fungi should not be part of a routine assessment. This is because decisions about appropriate remediation strategies can usually be made on the basis of a visual inspection. In addition, air-sampling methods for some fungi are prone to false negative results and therefore cannot be used to definitively rule out contamination.
- b. Air monitoring may be necessary if an individual(s) has been diagnosed with a disease that is or may be associated with a fungal exposure (e.g., pulmonary hemorrhage/hemosiderosis, and aspergillosis).
- c. Air monitoring may be necessary if there is evidence from a visual inspection or bulk sampling that ventilation systems may be contaminated. The purpose of such air monitoring is to assess the extent of contamination throughout a building. It is preferable to conduct sampling while ventilation systems are operating.
- d. Air monitoring may be necessary if the presence of mold is suspected (e.g., musty odors) but cannot be identified by a visual inspection or bulk sampling (e.g., mold growth behind walls). The purpose of such air monitoring is to determine the location and/or extent of contamination.
- e. If air monitoring is performed, for comparative purposes, outdoor air samples should be collected concurrently at an air intake, if possible, and at a location representative of outdoor air. For additional information on air sampling, refer to the American Conference of Governmental Industrial Hygienists' document, "Bioaerosols: Assessment and Control."
- f. Personnel conducting the sampling must be trained in proper air sampling methods for microbial contaminants. A laboratory specializing in mycology should be consulted for specific sampling and shipping instructions.

2.4 Analysis of Environmental Samples

Microscopic identification of the spores/colonies requires considerable expertise. These services are not routinely available from commercial laboratories. Documented quality control in the laboratories used for analysis of the bulk/surface and air samples is necessary. The American Industrial Hygiene Association (AIHA) offers accreditation to microbial laboratories (Environmental Microbiology Laboratory Accreditation Program (EMLAP)). Accredited laboratories must participate in quarterly proficiency testing (Environmental Microbiology Proficiency Analytical Testing Program (EMPAT)).

Evaluation of bulk/surface and air sampling data should be performed by an experienced health professional. The presence of few or trace amounts of fungal spores in bulk/surface sampling should be considered background. Amounts greater than this or the presence of fungal fragments (e.g., hyphae, and conidiophores) may suggest fungal colonization, growth, and/or accumulation at or near the sampled location.³⁰ Air samples should be evaluated by means of comparison (i.e., indoors to outdoors) and by fungal type (e.g., genera, and species). In general, the levels and types of fungi found should be similar indoors (in non-problem buildings) as compared to the outdoor air. Differences in the levels or types of fungi found in air samples may indicate that moisture sources and resultant fungal growth may be problematic.

top of page

3. Remediation

In all situations, the underlying cause of water accumulation must be rectified or fungal growth will recur. Any initial water infiltration should be stopped and cleaned immediately. An immediate response (within 24 to 48 hours) and thorough clean up, drying, and/or removal of water damaged materials will prevent or limit mold growth. If the source of water is elevated humidity, relative humidity should be maintained at levels below 60% to inhibit mold growth.³¹ Emphasis should be on ensuring proper repairs of the building infrastructure, so that water damage and moisture buildup does not recur.

Five different levels of abatement are described below. The size of the area impacted by fungal contamination primarily determines the type of remediation. The sizing levels below are based on professional judgement and practicality; currently there is not adequate data to relate the extent of contamination to frequency or severity of health effects. **The goal of remediation is to remove or clean contaminated materials in a way that prevents the emission of fungi and dust contaminated with fungi from leaving a work area and entering an occupied or non-abatement area, while protecting the health of workers performing the abatement.** The listed remediation methods were designed to achieve this goal, however, due to the general nature of these methods it is the responsibility of the people conducting remediation to ensure the methods enacted are adequate. The listed remediation methods are not meant to exclude other

similarly effective methods. Any changes to the remediation methods listed in these guidelines, however, should be carefully considered prior to implementation.

Non-porous (e.g., metals, glass, and hard plastics) and semi-porous (e.g., wood, and concrete) materials that are structurally sound and are visibly moldy can be cleaned and reused. Cleaning should be done using a detergent solution. Porous materials such as ceiling tiles and insulation, and wallboards with more than a small area of contamination should be removed and discarded. Porous materials (e.g., wallboard, and fabrics) that can be cleaned, can be reused, but should be discarded if possible. A professional restoration consultant should be contacted when restoring porous materials with more than a small area of fungal contamination. All materials to be reused should be dry and visibly free from mold. Routine inspections should be conducted to confirm the effectiveness of remediation work.

The use of gaseous, vapor-phase, or aerosolized biocides for remedial purposes is **not** recommended. The use of biocides in this manner can pose health concerns for people in occupied spaces of the building and for people returning to the treated space if used improperly. Furthermore, the effectiveness of these treatments is unproven and does not address the possible health concerns from the presence of the remaining non-viable mold. For additional information on the use of biocides for remedial purposes, refer to the American Conference of Governmental Industrial Hygienists' document, "Bioaerosols: Assessment and Control."

3.1 Level I: Small Isolated Areas (10 sq. ft or less) - e.g., ceiling tiles, small areas on walls

- a. Remediation can be conducted by regular building maintenance staff. Such persons should receive training on proper clean up methods, personal protection, and potential health hazards. This training can be performed as part of a program to comply with the requirements of the OSHA Hazard Communication Standard (29 CFR 1910.1200).
- b. Respiratory protection (e.g., N95 disposable respirator), in accordance with the OSHA respiratory protection standard (29 CFR 1910.134), is recommended. Gloves and eye protection should be worn.
- c. The work area should be unoccupied. Vacating people from spaces adjacent to the work area is not necessary but is recommended in the presence of infants (less than 12 months old), persons recovering from recent surgery, immune suppressed people, or people with chronic inflammatory lung diseases (e.g., asthma, hypersensitivity pneumonitis, and severe allergies).
- d. Containment of the work area is not necessary. Dust suppression methods, such as misting (not soaking) surfaces prior to remediation, are recommended.
- e. Contaminated materials that cannot be cleaned should be removed from the building in a sealed plastic bag. There are no special requirements for the disposal of moldy materials.
- f. The work area and areas used by remedial workers for egress should be cleaned with a damp cloth and/or mop and a detergent solution.
- g. All areas should be left dry and visibly free from contamination and debris.

3.2 Level II: Mid-Sized Isolated Areas (10 - 30 sq. ft.) - e.g., individual wallboard panels.

- a. Remediation can be conducted by regular building maintenance staff. Such persons should receive training on proper clean up methods, personal protection, and potential health hazards. This training can be performed as part of a program to comply with the requirements of the OSHA Hazard Communication Standard (29 CFR 1910.1200).
- b. Respiratory protection (e.g., N95 disposable respirator), in accordance with the OSHA respiratory protection standard (29 CFR 1910.134), is recommended. Gloves and eye protection should be worn.
- c. The work area should be unoccupied. Vacating people from spaces adjacent to the work area is not necessary but is recommended in the presence of infants (less than 12 months old), persons having undergone recent surgery, immune suppressed people, or people with chronic inflammatory lung diseases (e.g., asthma, hypersensitivity pneumonitis, and severe allergies).
- d. The work area should be covered with a plastic sheet(s) and sealed with tape before remediation, to contain dust/debris.
- e. Dust suppression methods, such as misting (not soaking) surfaces prior to remediation, are recommended.
- f. Contaminated materials that cannot be cleaned should be removed from the building in sealed plastic bags. There are no special requirements for the disposal of moldy materials.
- g. The work area and areas used by remedial workers for egress should be HEPA vacuumed (a vacuum equipped with a High-Efficiency Particulate Air filter) and cleaned with a damp cloth and/or mop and a detergent solution.
- h. All areas should be left dry and visibly free from contamination and debris.

3.3 Level III: Large Isolated Areas (30 - 100 square feet) - e.g., several wallboard panels.

 A health and safety professional with experience performing microbial investigations should be consulted prior to remediation activities to provide oversight for the project.

The following procedures *at a minimum* are recommended:

- a. Personnel trained in the handling of hazardous materials and equipped with respiratory protection, (e.g., N95 disposable respirator), in accordance with the OSHA respiratory protection standard (29 CFR 1910.134), is recommended. Gloves and eye protection should be worn.
- b. The work area and areas directly adjacent should be covered with a plastic sheet(s) and taped before remediation, to contain dust/debris.
- c. Seal ventilation ducts/grills in the work area and areas directly adjacent with plastic sheeting.
- d. The work area and areas directly adjacent should be unoccupied. Further vacating of people from spaces near the work area is recommended in the presence of infants (less than 12 months old), persons having undergone recent surgery, immune suppressed people, or people with chronic inflammatory lung diseases (e.g., asthma, hypersensitivity pneumonitis, and severe allergies).
- e. Dust suppression methods, such as misting (not soaking) surfaces prior to remediation, are recommended.
- f. Contaminated materials that cannot be cleaned should be removed from the building in sealed plastic bags. There are no special requirements for the disposal of moldy materials.
- g. The work area and surrounding areas should be HEPA vacuumed and cleaned with a damp cloth and/or mop and a detergent solution.
- h. All areas should be left dry and visibly free from contamination and debris.

If abatement procedures are expected to generate a lot of dust (e.g., abrasive cleaning of contaminated surfaces, demolition of plaster walls) or the visible concentration of the fungi is heavy (blanket coverage as opposed to patchy), then it is recommended that the remediation procedures for Level IV are followed.

3.4 Level IV: Extensive Contamination (greater than 100 contiguous square feet in an area)

 A health and safety professional with experience performing microbial investigations should be consulted prior to remediation activities to provide oversight for the project. The following procedures are recommended:

- a. Personnel trained in the handling of hazardous materials equipped with:
 - i. Full-face respirators with high efficiency particulate air (HEPA) cartridges
 - ii. Disposable protective clothing covering both head and shoes
 - iii. Gloves
- b. Containment of the affected area:
 - i. Complete isolation of work area from occupied spaces using plastic sheeting sealed with duct tape (including ventilation ducts/grills, fixtures, and any other openings)
 - ii. The use of an exhaust fan with a HEPA filter to generate negative pressurization
 - iii. Airlocks and decontamination room
- c. Vacating people from spaces adjacent to the work area is not necessary but is recommended in the presence of infants (less than 12 months old), persons having undergone recent surgery, immune suppressed people, or people with chronic inflammatory lung diseases (e.g., asthma, hypersensitivity pneumonitis, and severe allergies).
- d. Contaminated materials that cannot be cleaned should be removed from the building in sealed plastic bags. The outside of the bags should be cleaned with a damp cloth and a detergent solution or HEPA vacuumed in the decontamination chamber prior to their transport to uncontaminated areas of the building. There are no special requirements for the disposal of moldy materials.
- e. The contained area and decontamination room should be HEPA vacuumed and cleaned with a damp cloth and/or mop with a detergent solution and be visibly clean prior to the removal of isolation barriers.
- f. Air monitoring should be conducted prior to occupancy to determine if the area is fit to reoccupy.

3.5 Level V: Remediation of HVAC Systems

3.5.1 A Small Isolated Area of Contamination (<10 square feet) in the HVAC System

- a. Remediation can be conducted by regular building maintenance staff. Such persons should receive training on proper clean up methods, personal protection, and potential health hazards. This training can be performed as part of a

- program to comply with the requirements of the OSHA Hazard Communication Standard (29 CFR 1910.1200).
- b. Respiratory protection (e.g., N95 disposable respirator), in accordance with the OSHA respiratory protection standard (29 CFR 1910.134), is recommended. Gloves and eye protection should be worn.
 - c. The HVAC system should be shut down prior to any remedial activities.
 - d. The work area should be covered with a plastic sheet(s) and sealed with tape before remediation, to contain dust/debris.
 - e. Dust suppression methods, such as misting (not soaking) surfaces prior to remediation, are recommended.
 - f. Growth supporting materials that are contaminated, such as the paper on the insulation of interior lined ducts and filters, should be removed. Other contaminated materials that cannot be cleaned should be removed in sealed plastic bags. There are no special requirements for the disposal of moldy materials.
 - g. The work area and areas immediately surrounding the work area should be HEPA vacuumed and cleaned with a damp cloth and/or mop and a detergent solution.
 - h. All areas should be left dry and visibly free from contamination and debris.
 - i. A variety of biocides are recommended by HVAC manufacturers for use with HVAC components, such as, cooling coils and condensation pans. HVAC manufacturers should be consulted for the products they recommend for use in their systems.

3.5.2 Areas of Contamination (>10 square feet) in the HVAC System

A health and safety professional with experience performing microbial investigations should be consulted prior to remediation activities to provide oversight for remediation projects involving more than a small isolated area in an HVAC system. The following procedures are recommended:

- a. Personnel trained in the handling of hazardous materials equipped with:
 - i. Respiratory protection (e.g., N95 disposable respirator), in accordance with the OSHA respiratory protection standard (29 CFR 1910.134), is recommended.
 - ii. Gloves and eye protection
 - iii. Full-face respirators with HEPA cartridges and disposable protective clothing covering both head and shoes should be worn if contamination is greater than 30 square feet.
- b. The HVAC system should be shut down prior to any remedial activities.
- c. Containment of the affected area:
 - i. Complete isolation of work area from the other areas of the HVAC system using plastic sheeting sealed with duct tape.
 - ii. The use of an exhaust fan with a HEPA filter to generate negative pressurization.
 - iii. Airlocks and decontamination room if contamination is greater than 30 square feet.
- d. Growth supporting materials that are contaminated, such as the paper on the insulation of interior lined ducts and filters, should be removed. Other contaminated materials that cannot be cleaned should be removed in sealed plastic bags. When a decontamination chamber is present, the outside of the bags should be cleaned with a damp cloth and a detergent solution or HEPA vacuumed prior to their transport to uncontaminated areas of the building. There are no special requirements for the disposal of moldy materials.
- e. The contained area and decontamination room should be HEPA vacuumed and cleaned with a damp cloth and/or mop and a detergent solution prior to the removal of isolation barriers.
- f. All areas should be left dry and visibly free from contamination and debris.
- g. Air monitoring should be conducted prior to re-occupancy with the HVAC system in operation to determine if the area (s) served by the system are fit to reoccupy.
- h. A variety of biocides are recommended by HVAC manufacturers for use with HVAC components, such as, cooling coils and condensation pans. HVAC manufacturers should be consulted for the products they recommend for use in their systems.

top of page

4. Hazard Communication

When fungal growth requiring large-scale remediation is found, the building owner, management, and/or employer should notify occupants in the affected area(s) of its presence. Notification should include a description of the remedial measures to be taken and a timetable for completion. Group meetings held before and after remediation with full disclosure of plans and results can be an effective communication mechanism. Individuals with persistent health problems that appear to be related to bioaerosol exposure should see their physicians for a referral to practitioners who are trained in

occupational/environmental medicine or related specialties and are knowledgeable about these types of exposures. Individuals seeking medical attention should be provided with a copy of all inspection results and interpretation to give to their medical practitioners.

top of page

Conclusion

In summary, the prompt remediation of contaminated material and infrastructure repair must be the primary response to fungal contamination in buildings. The simplest and most expedient remediation that properly and safely removes fungal growth from buildings should be used. In all situations, the underlying cause of water accumulation must be rectified or the fungal growth will recur. Emphasis should be placed on preventing contamination through proper building maintenance and prompt repair of water damaged areas.

Widespread contamination poses much larger problems that must be addressed on a case-by-case basis in consultation with a health and safety specialist. Effective communication with building occupants is an essential component of all remedial efforts. Individuals with persistent health problems should see their physicians for a referral to practitioners who are trained in occupational/environmental medicine or related specialties and are knowledgeable about these types of exposures.

top of page

Notes and References

1. Bata A, Harrach B, Kalman U, Kis-tamas A, Laszity R. Macrocyclic Trichothecene Toxins Produced by *Stachybotrys atra* Strains Isolated in Middle Europe. *Applied and Environmental Microbiology* 1985; **49**:678-81.
2. Jarvis B, "Mycotoxins and Indoor Air Quality," *Biological Contaminants in Indoor Environments, ASTM STP 1071*, Morey P, Feely Sr. J, Otten J, Editors, American Society for Testing and Materials, Philadelphia, 1990.
3. Yang C, Johanning E, "Airborne Fungi and Mycotoxins," *Manual of Environmental Microbiology*, Hurst C, Editor in Chief, ASM Press, Washington, D.C., 1996
4. Jarvis B, Mazzola E. Macrocyclic and Other Novel Trichothecenes: Their Structure, Synthesis, and Biological Significance. *Acc. Chem. Res.* 1982; **15**:388-95.
5. Von Essen S, Robbins R, Thompson A, Rennard S. Organic Dust Toxic Syndrome: An Acute Febrile Reaction to Organic Dust Exposure Distinct from Hypersensitivity Pneumonitis. *Clinical Toxicology* 1990; **28(4)**:389-420.
6. Richerson H. Unifying Concepts Underlying the Effects of Organic Dust Exposures. *American Journal of Industrial Medicine* 1990; **17**:139-42.
7. Malmberg P, Rask-Andersen A, Lundholm M, Palmgren U. Can Spores from Molds and Actinomycetes Cause an Organic Dust Toxic Syndrome Reaction?. *American Journal of Industrial Medicine* 1990; **17**:109-10.
8. Malmberg P. Health Effects of Organic Dust Exposure in Dairy Farmers. *American Journal of Industrial Medicine* 1990; **17**:7-15.
9. Yoshida K, Masayuki A, Shukuro A. Acute Pulmonary Edema in a Storehouse of Moldy Oranges: A Severe Case of the Organic Dust Toxic Syndrome. *Archives of Environmental Health* 1989; **44(6)**: 382-84.
10. Lecours R, Laviolette M, Cormier Y. Bronchoalveolar Lavage in Pulmonary Mycotoxicosis. *Thorax* 1986; **41**:924-6.
11. Levetin E. "Fungi," *Bioaerosols*, Burge H, Editor, CRC Press, Boca Raton, Florida, 1995.
12. Husman T. Health Effects of Indoor-air Microorganisms. *Scand J Work Environ Health* 1996; **22**:5-13.
13. Miller J D. Fungi and Mycotoxins in Grain: Implications for Stored Product Research. *J Stored Prod Res* 1995; **31(1)**:1-16.
14. Cookingham C, Solomon W. "Bioaerosol-Induced Hypersensitivity Diseases," *Bioaerosols*, Burge H, Editor, CRC Press, Boca Raton, Florida, 1995.
15. Rautiala S, Reponen T, Nevalainen A, Husman T, Kallioikoski P. Control of Exposure to Airborne Viable Microorganisms During Remediation of Moldy Buildings; Report of Three Case Studies. *American Industrial Hygiene Association Journal* 1998; **59**:455-60.
16. Dales R, Zwanenburg H, Burnett R, Franklin C. Respiratory Health Effects of Home Dampness and Molds among Canadian Children. *American Journal of Epidemiology* 1991; **134(2)**: 196-203.
17. Hodgson M, Morey P, Leung W, Morrow L, Miller J D, Jarvis B, Robbins H, Halsey J, Storey E. Building-Associated Pulmonary Disease from Exposure to *Stachybotrys chartarum* and *Aspergillus versicolor*. *Journal of Occupational and Environmental Medicine* 1998; **40(3)**:241-9.
18. Croft W, Jarvis B, Yatawara C. Airborne Outbreak of Trichothecene Toxicosis. *Atmospheric Environment* 1986; **20(3)** 549-52.

19. DeKoster J, Thorne P. Bioaerosol Concentrations in Noncomplaint, Complaint, and Intervention Homes in the Midwest. *American Industrial Hygiene Association Journal* 1995; **56**:573-80.
20. Johanning E, Biagini R, Hull D, Morey P, Jarvis B, Landbergis P. Health and Immunological Study Following Exposure to Toxicogenic Fungi (*Stachybotrys chartarum*) in a Water-Damaged Office Environment. *Int Arch Occup Environ Health* 1996; **68**:207-18.
21. Montana E, Etzel R, Allan T, Horgan T, Dearborn D. Environmental Risk Factor Associated with Pediatric Idiopathic Pulmonary Hemorrhage and Hemosiderosis in a Cleveland Community. *Pediatrics* 1997; **99**(1)
22. Etzel R, Montana E, Sorenson W G, Kullman G, Allan T, Dearborn D. Acute Pulmonary Hemorrhage in Infants Associated with Exposure to *Stachybotrys atra* and Other Fungi. *Ach Pediatr Adolesc Med* 1998; **152**:757-62.
23. CDC. Update: Pulmonary Hemorrhage/Hemosiderosis Among Infants --- Cleveland, Ohio, 1993 - 1996. *MMWR* 2000; **49**(9): 180-4.
24. Burge H, Otten J. "Fungi," *Bioaerosols Assessment and Control*, Macher J, Editor, American Conference of Industrial Hygienists, Cincinnati, Ohio, 1999.
25. do Pico G. Hazardous Exposure and Lung Disease Among Farm Workers. *Clinics in Chest Medicine* 1992; **13**(2):311-28.
26. Hodgson M, Morey P, Attfield M, Sorenson W, Fink J, Rhodes W, Visvesvara G. Pulmonary Disease Associated with Cafeteria Flooding. *Archives of Environmental Health* 1985; **40**(2):96-101.
27. Weltermann B, Hodgson M, Storey E, DeGraff, Jr. A, Bracker A, Groseclose S, Cole S, Cartter M, Phillips D. Hypersensitivity Pneumonitis: A Sentinel Event Investigation in a Wet Building. *American Journal of Industrial Medicine* 1998; **34**:499-505.
28. Band J. "Histoplasmosis," *Occupational Respiratory Diseases*, Merchant J, Editor, U.S. Department of Health and Human Services, Washington D.C., 1986.
29. Bertolini R. "Histoplasmosis A Summary of the Occupational Health Concern," Canadian Centre for Occupational Health and Safety. Hamilton, Ontario, Canada, 1988.
30. Yang C. P&K Microbiology Services, Inc. Microscopic Examination of Sticky Tape or Bulk Samples for the Evaluation and Identification of Fungi. Cherry Hill, New Jersey.
31. American Society of Heating, Refrigerating and Air-Conditioning Engineers, Inc. Thermal Environmental Conditions for Human Occupancy - ASHRAE Standard (ANSI/ASHRAE 55-1992). Atlanta, Georgia, 1992.

top of page

Acknowledgments

The New York City Department of Health would like to thank the following individuals and organizations for participating in the revision of these guidelines. Please note that these guidelines do not necessarily reflect the opinions of the participants nor their organizations.

| Name | Company/Institution |
|----------------------|---|
| Dr. Susan Klitzman | Hunter College |
| Dr. Philip Morey | AQS Services, Inc |
| Dr. Donald Ahearn | Georgia State University |
| Dr. Sidney Crow | Georgia State University |
| Dr. J. David Miller | Carleton University |
| Dr. Bruce Jarvis | University of Maryland at College Park |
| Mr. Ed Light | Building Dynamics, LLC |
| Dr. Chin Yang | P&K Microbiology Services, Inc |
| Dr. Harriet Burge | Harvard School of Public Health |
| Dr. Dorr Dearborn | Rainbow Children's Hospital |
| Mr. Eric Esswein | National Institute for Occupational Safety and Health |
| Dr. Ed Horn | The New York State Department of Health |
| Dr. Judith Schreiber | The New York State Department of Health |
| Mr. Gregg Recer | The New York State Department of Health |
| Dr. Gerald Llewellyn | State of Delaware, Division of Public Health |
| Mr. Daniel Price | Interface Research Corporation |

Ms. Sylvia Pryce

Mr. Armando Chamorro

Ms. Marie-Alix d'Halewyn

Dr. Elissa A. Favata

Dr. Harriet Ammann

Mr. Terry Allan

The NYC Citywide Office of Occupational Safety and Health

Ambient Environmental

Laboratoire de santé publique du Québec

Environmental and Occupational Health Associates

Washington State Department of Health

Cuyahoga County Board of Health

We would also like to thank the many others who offered opinions, comments, and assistance at various stages during the development of these guidelines.

Christopher D'Andrea, M.S. of the Environmental and Occupational Disease Epidemiology Unit, was the editor of this document.

For further information regarding this document please contact the New York City Department of Health at 311.

[Go Back to DOHMH Page](#)

ATTACHMENT 2

DTW ATCT MOLD REMEDIATION PROJECT CLEARANCE PROTOCOL

Mold Remediation Project Clearance Protocol

PREPARED FOR:

FEDERAL AVIATION ADMINISTRATION

**Detroit Metropolitan Wayne County
Airport Traffic Control Tower
(DTW ATCT)**

DETROIT, MICHIGAN

June 13, 2008



PREPARED BY:

Barbara Hebert, CIH
NISC, KANSAS CITY ARTCC DISTRICT TSU

The **DTW ATCT Mold Remediation and Restoration Project** will include the removal of moisture and microbiological-contaminated gypsum board, shaft liner, and insulation.

After Rooms 928 and 428 have passed a thorough visual inspection, and before the outer containment barrier is removed, clearance air sampling will be performed.

Five consecutive samples will be collected inside the containment area using a high volume air sampler and Zefon Air-O-Cell® cassettes. Sampling will be conducted at a flow rate of 15 liters per minute for a period of five minutes each, resulting in a collection volume of 75 liters of air. Environmental conditions may warrant the sample collection period to be reduced to one-minute intervals, in order to reduce the collection of non-microbial particulates that can mask the presence of mold spores.

Three consecutive samples will be collected outside the containment area, but inside the ATCT in a noncomplaint area, in the same manner as above. Sampling will be conducted at a flow rate of 15 liters per minute for a period of five minutes each, resulting in a collection volume of 75 liters of air.

Three consecutive samples will be collected outside of the building, in the same manner as above. Sampling will be conducted at a flow rate of 15 liters per minute for a period of 10 minutes each, resulting in a collection volume of 150 liters of air.

For all samples collected, the high volume air sampler will be calibrated before and after use.

All samples, one lab blank, and a completed Chain of Custody form will be sent to Aerotech Laboratories, Inc., by Federal Express Priority Overnight delivery. The samples will be mailed in a rigid container or box. There is no additional temperature handling requirement.

All samples will be clearly labeled. The sample identification number appearing on the cassette **must** match the identification number shown on the Chain of Custody form. The samples will be analyzed in accordance with **Aerotech Method A001** (equivalent to the cassette manufacturer's recommended analytical procedure) via light microscopy at 600X magnification, with the entire slide (100% of the sample) being analyzed. The results will be reported as a total fungal spore count, in counts per cubic meter (counts/M³), which includes both viable and non-viable spores.

The area will be considered "clean" when the average airborne total mold spore concentration measured inside the containment area was not statistically higher than the average airborne concentration measured outside the containment area, **and** the **genus level** constituents similar for all samples taken inside the containment, inside the building (but outside of the containment) and outside of the building.

Statistical significance may be determined in the following manner:

A. All containment sample airborne total concentration levels are lower than those taken from outside the containment, or

B. The Z-test score is less than or equal to 1.65 Standard Deviations from the Mean, indicating a 90% confidence interval. The Z-test is carried out by calculating:

$$Z = \frac{Y_1 - Y_0}{0.8 (1/n_1 + 1/n_0)^{1/2}}$$

where Y_1 is the average of the natural logarithms of the inside samples, Y_0 is the average of the natural logarithms of the outside samples, n_1 is the number of inside samples and n_0 is the number of outside samples.

Alternative A shall be considered first, then if necessary, Alternative B. Should the calculated Z-test score exceed 1.65, the abatement area must be recleaned. An additional set of 10 samples must then be collected, as defined above, in order to establish clearance.

The **genus level** constituents will be evaluated using the Spearman Rank Order Correlation (SROC), which is a statistical technique used to test the direction and strength of the relationship between two variables. It uses the statistic "Rs", which falls between -1 and +1. If the "Rs" value is -1, there is a perfect negative correlation; between -1 and -0.5, there is a strong negative correlation; between -0.5 and 0, there is a weak negative correlation; if 0, there is no correlation; between 0 and 0.5, there is a weak positive correlation; between 0.5 and 1, there is a strong positive correlation; and if 1, there is a perfect positive correlation. Calculated "Rs" values will also be compared to the Critical Values (CV) listed in Table 13.7 of the American Conference of Governmental Industrial Hygienists "Bioaerosols: Assessment and Control", which are drawn from a standard statistical table. Comparing the "Rs" value to the CV permits a methodical acceptance or rejection. If the "Rs" value exceeds the 0.1 confidence level, the populations appear to be related or similar. If the "Rs" value is below the 0.1 confidence level, the populations do not appear to be related or are different. Should the "Rs" value be below the 0.1 confidence level, the remediation area must be recleaned unless a professional opinion can justify rank differences to be insignificant.

Once the abatement area has passed the clearance criteria, the outer containment barrier will be removed and the room will be available for restoration.

Visual inspections and clearance air sampling will be performed upon completion of the mold remediation, but prior to the re-installation of new building materials.

The visual inspection, clearance air sampling, and data interpretation will be conducted by the government-retained Industrial Hygienist.



DEPARTMENT OF TRANSPORTATION
FEDERAL AVIATION ADMINISTRATION
GREAT LAKES REGION - CHICAGO, ILLINOIS

MICROBIOLOGICAL REMEDIATION
ATCT
DETROIT METROPOLITAN WAYNE COUNTY AIRPORT
DETROIT, MICHIGAN

DRAWING LIST

| <u>DRAWING NUMBER</u> | <u>DRAWING NAME</u> | <u>REV.#</u> | <u>DATE</u> |
|-----------------------|--------------------------------------|--------------|-------------|
| GL-D-414C-CSP | CONSTRUCTION SAFETY PLAN | | 04/25/07 |
| DTW-D-ATCT-A03 | MOISTURE DAMAGE REMEDIATION 3RD FL. | 1 | 08/08/08 |
| DTW-D-ATCT-A04 | MOISTURE DAMAGE REMEDIATION 4TH FL. | 1 | 08/08/08 |
| DTW-D-ATCT-A05 | MOISTURE DAMAGE REMEDIATION 5TH FL. | 1 | 08/08/08 |
| DTW-D-ATCT-A06 | MOISTURE DAMAGE REMEDIATION 6TH FL. | 1 | 08/08/08 |
| DTW-D-ATCT-A07 | MOISTURE DAMAGE REMEDIATION 7TH FL. | 1 | 08/08/08 |
| DTW-D-ATCT-A08 | MOISTURE DAMAGE REMEDIATION 8TH FL. | 1 | 08/08/08 |
| DTW-D-ATCT-A09 | MOISTURE DAMAGE REMEDIATION 9TH FL. | 1 | 08/08/08 |
| DTW-D-ATCT-A10 | MOISTURE DAMAGE REMEDIATION 10TH FL. | 1 | 08/08/08 |
| DTW-D-ATCT-A11 | MOISTURE DAMAGE REMEDIATION DETAILS | 0 | 08/06/08 |

SCOPE OF WORK

FLOOR 3:

1. PRIOR TO PERFORMING MICROBIOLOGICAL REMEDIATION PROCEDURES, THE CONTRACTOR SHALL SEAL ALL CRITICAL PENETRATIONS AND OPENINGS TO THE WORK AREA WITH A MINIMUM OF TWO LAYERS OF 6-MIL POLYETHYLENE, AND SHALL BE RESPONSIBLE FOR ENSURING ADJOINING AREAS ARE NOT EXPOSED TO THE MICROBIOLOGICAL CONTAMINATION DURING THE REMEDIATION.
2. REMOVE ANY MCM BETWEEN THE BOTTOM METAL RUNNER/TRACK AND THE CONCRETE FLOOR; BETWEEN THE TOP METAL RUNNER/TRACK AND THE STRUCTURAL DECK; AND BETWEEN THE METAL STUD AND EXTERIOR CONCRETE WALL.
3. THE CONTRACTOR SHALL MINIMIZE DUST GENERATION AND USE THE METHODOLOGIES OUTLINED IN GARFIE FOR DUST PREVENTION AND SUPPRESSION.
4. ALL REMOVALS AND OTHER CLEANING PROCEDURES SHALL BE CONDUCTED AT NIGHT BETWEEN THE HOURS OF 11:00 PM AND 6:00 AM. NEGATIVE AIR PRESSURE EQUIPMENT SHALL BE EQUIPPED WITH A HEPA FILTER AND DISCHARGED OUTSIDE OF THE BUILDING. WHENEVER POSSIBLE OTHERWISE DISCHARGED THROUGH A SECOND HEPA FILTER IN ORDER TO PERMIT RECIRCULATION OF AIR INSIDE THE BUILDING.
5. ONCE THE MOLD HAS BEEN REMOVED AND CLEARANCE HAS BEEN ACHIEVED, AND THE STAINED SURFACES HAVE BEEN CLEANED, THEN REMOVE ALL PARTITION WALLS, DOORS AND DOOR FRAMES EXCEPT THOSE AROUND THE ELEVATOR CORE AND STAIRWELL.
6. CUT A 1/2" GAP BETWEEN THE BOTTOM OF THE GYPSUM BOARD AND CONCRETE DECK. FILL THE GAP WITH A 2-HR FIRE-RATED CAULK IN THE REMAINING PARTITION WALLS AROUND THE ELEVATOR CORE AND STAIRWELL CORRIDOR.
7. PAINT ELEVATOR CORE EXTERIOR AND STAIRWELL CORRIDOR WITH MOLD RESISTANT PAINT.
8. FURNISH AND INSTALL FIRE-RATED ACCESS PANELS IN THE CENTER OF THE NORTH AND EAST ELEVATOR CORE WALL. THE BOTTOM OF THE PANEL SHALL BE 24" ABOVE THE FLOOR. DO NOT PENETRATE THE SHAFT LINER. SEE DETAIL "B" ON DWG DTW-D-ATCT-AH.

ROOM 327

1. THE CONTRACTOR SHALL PROVIDE ADDITIONAL CLEANING PROCEDURES AND PIPE INSULATION REMOVAL/REPLACEMENT.
2. APPROXIMATELY 15 LINEAR FEET OF 18" WATER STAINED AND/OR CONTAMINATED CHILLED AND HEATING WATER PIPE INSULATION SHALL BE REMOVED AND REPLACED.

ROOM 328

1. A MINICONTAINMENT SHALL BE ESTABLISHED CONSISTING OF A SINGLE LAYER OF 6-MIL POLYETHYLENE SHEETING. A NEGATIVE PRESSURE ENCLOSURE SYSTEM SHALL BE ESTABLISHED AS DESCRIBED IN SECTION 18.9 REMEDIATION AREA.
2. THE EAST (ELEVATOR SHAFT) WALL UP TO A HEIGHT OF 2', AND THE SOUTH (ELEVATOR SHAFT) WALL UP TO A HEIGHT OF 2', SHALL BE HEPA VACUUMED AND THEN WET WIPED WITH AN APPROVED CLEANING SOLUTION.

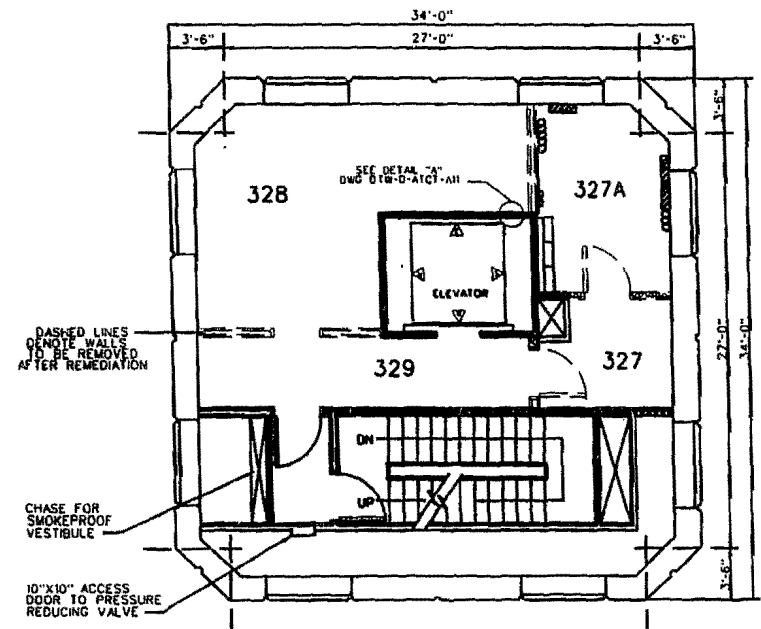

THIRD FLOOR SHAFT PLAN

NOT TO SCALE

| | |
|---|---------------------|
| DEPARTMENT OF TRANSPORTATION FEDERAL AVIATION ADMINISTRATION | |
| DRAWN BY: [blank] | CHECKED BY: [blank] |
| MOISTURE DAMAGE REMEDIATION 3RD FLOOR ATCT | |
| DETROIT METRO WAREHOUSE AIRPORT DETROIT, MICHIGAN | |
| DATE: [blank] | PROJECT NO: [blank] |
| SCALE: [blank] | SHEET NO: [blank] |

| | | | |
|-----|----------------------------|------|----|
| NO. | REVISION | DATE | BY |
| 1 | ISSUED FOR MOISTURE DAMAGE | | |

SCOPE OF WORK

FLOOR 4:

1. PRIOR TO PERFORMING MICROBIOLOGICAL REMEDIATION PROCEDURES, THE CONTRACTOR SHALL SEAL ALL CRITICAL PENETRATIONS AND OPENINGS TO THE WORK AREA WITH A MINIMUM OF TWO LAYERS OF 6-MIL POLYETHYLENE, AND SHALL BE RESPONSIBLE FOR ENSURING ADJOINING AREAS ARE NOT EXPOSED TO THE MICROBIOLOGICAL CONTAMINATION DURING THE REMEDIATION.
2. REMOVE ANY MCM BETWEEN THE BOTTOM METAL RUNNER/TRACK AND THE CONCRETE FLOOR; BETWEEN THE TOP METAL RUNNER/TRACK AND THE STRUCTURAL DECK; AND BETWEEN THE METAL STUD AND EXTERIOR CONCRETE WALL.
3. THE CONTRACTOR SHALL MINIMIZE DUST GENERATION AND USE THE METHODOLOGIES OUTLINED IN GARFIE FOR DUST PREVENTION AND SUPPRESSION.
4. ALL REMOVALS AND OTHER CLEANING PROCEDURES SHALL BE CONDUCTED AT NIGHT BETWEEN THE HOURS OF 11:00 PM AND 6:00AM. NEGATIVE AIR PRESSURE EQUIPMENT SHALL BE EQUIPPED WITH A HEPA FILTER AND DISCHARGED OUTSIDE OF THE BUILDING WHENEVER POSSIBLE, OTHERWISE DISCHARGED THROUGH A SECOND HEPA FILTER IN ORDER TO PERMIT RECIRCULATION OF AIR INSIDE THE BUILDING.
5. ONCE THE MOLD HAS BEEN REMOVED AND CLEARANCE HAS BEEN ACHIEVED, AND THE STAINED SURFACES HAVE BEEN CLEANED, THEN REMOVE ALL PARTITION WALLS, DOORS AND DOOR FRAMES, EXCEPT THOSE AROUND THE ELEVATOR CORE AND STAIRWELL.
6. CUT A 1/2" GAP BETWEEN THE BOTTOM OF THE GYPSUM BOARD AND THE CONCRETE DECK. FILL THE GAP WITH A 2-HR FIRE-RATED CAULK IN THE REMAINING PARTITION WALLS AROUND THE ELEVATOR CORE AND STAIRWELL CORRIDOR.
7. PAINT ELEVATOR CORE EXTERIOR AND STAIRWELL CORRIDOR WITH MOLD RESISTANT PAINT. PAINT MECHANICAL ENCLOSURE ON THIS FLOOR.
8. FURNISH AND INSTALL FIRE-RESISTANT ACCESS PANELS IN THE CENTER OF THE NORTH AND EAST ELEVATOR CORE WALL. THE BOTTOM OF THE PANEL SHALL BE 24" ABOVE THE FLOOR. DO NOT PENETRATE THE SHAFT LINER. SEE DETAIL "B" ON DWG DTW-D-ATCT-A11.

ROOM 427

1. THE CONTRACTOR SHALL PROVIDE ADDITIONAL CLEANING PROCEDURES AND PIPE INSULATION REMOVAL/REPLACEMENT.
2. APPROXIMATELY 4 LINEAR FEET OF 1" AND 6 LINEAR FEET OF 18" WATER STAINED AND/OR CONTAMINATED CHILLED AND HEATING WATER PIPE INSULATION SHALL BE REMOVED AND REPLACED.

ROOM 428

1. A CONTAINMENT AND NEGATIVE PRESSURE ENCLOSURE SYSTEM SHALL BE ESTABLISHED AS DESCRIBED IN SECTION 18.9 REMEDIATION AREA. A DECONTAMINATION UNIT SHALL BE ESTABLISHED AS DESCRIBED IN SECTION 18.10 DECONTAMINATION.
2. CLEANUP AND REMOVAL OF MOISTURE AND MICROBIOLOGICAL CONTAMINATED GYPSUM BOARD, SHAFT LINER, AND INSULATION IN THE DTW ATCT ROOM 428 IN ACCORDANCE WITH THE GUIDELINES ESTABLISHED BY THE NEW YORK CITY DEPARTMENT OF HEALTH ENTITLED GUIDELINES ON ASSESSMENT AND REMEDIATION OF FUNGUS IN INDOOR ENVIRONMENTS (GARFIE) (SEE SPECIFICATION ATTACHMENT 1).
3. REMOVE GYPSUM BOARD, SHAFT LINER, AND INSULATION TOTALING APPROXIMATELY 243 SQUARE FEET.
 - A. THE EAST (ELEVATOR SHAFT) WALL, 8' WIDE TO A HEIGHT OF 5' (SURFACE LAYER), 8' WIDE TO A HEIGHT OF 4'6" (CONCEALED LAYER), AND 8' WIDE TO A HEIGHT OF 4' (SHAFT LINER).
 - B. THE SOUTH (ELEVATOR SHAFT) WALL, 10' WIDE TO A HEIGHT OF 5' (SURFACE LAYER), 10' WIDE TO A HEIGHT OF 4'6" (CONCEALED LAYER), AND 10' WIDE TO A HEIGHT OF 4' (SHAFT LINER).
 - C. ELEVATOR SHAFT LINER REMOVAL AND REPLACEMENT REQUIRES COORDINATION WITH THE ELEVATOR MAINTENANCE CO. AND AIR TRAFFIC TO SCHEDULE LIMITED ELEVATOR SHUTDOWN TIME.

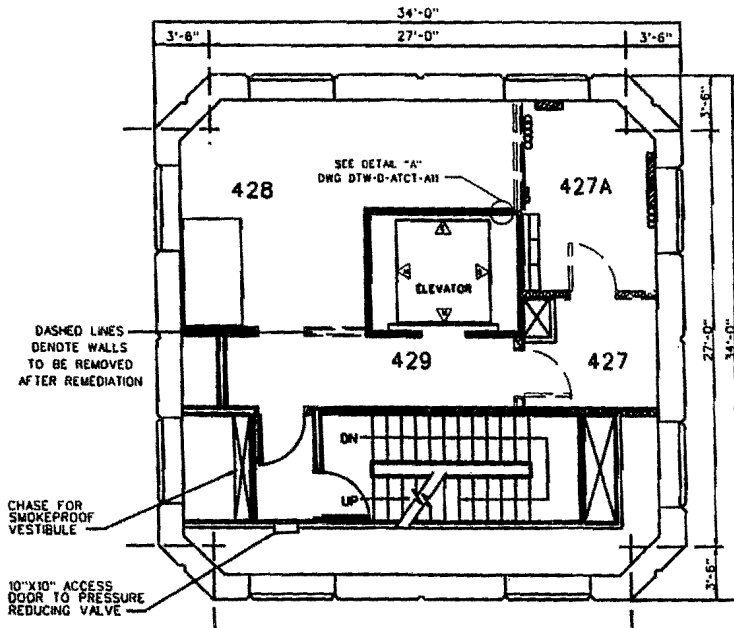

FOURTH FLOOR SHAFT PLAN

NOT TO SCALE

| | |
|--|---------------------|
| DEPARTMENT OF REMEDIATION FEDERAL BUREAU OF INVESTIGATION | |
| SHAFT LINER NO. 001 | 00000000 |
| MOISTURE DAMAGE REMEDIATION | |
| 4TH FLOOR | |
| ATCT | |
| DETROIT METRO WAREHOUSE AIRPORT | |
| DETROIT, MICHIGAN | |
| DATE: 8/8/2008 | DRAWN BY: [blank] |
| PROJECT: 4TH FL. MOISTURE DAMAGE | CHECKED BY: [blank] |
| DWG NO: DTW-D-ATCT-A11 | SCALE: [blank] |
| SHEET NO: 11 | TOTAL SHEETS: 17 |

SCOPE OF WORK

FLOOR 5:

1. PRIOR TO PERFORMING MICROBIOLOGICAL REMEDIATION PROCEDURES, THE CONTRACTOR SHALL SEAL ALL CRITICAL PENETRATIONS AND OPENINGS TO THE WORK AREA WITH A MINIMUM OF TWO LAYERS OF 6-MIL POLYETHYLENE, AND SHALL BE RESPONSIBLE FOR ENSURING ADJOINING AREAS ARE NOT EXPOSED TO THE MICROBIOLOGICAL CONTAMINATION DURING THE REMEDIATION.
2. REMOVE ANY MCM BETWEEN THE BOTTOM METAL RUNNER/TRACK AND THE CONCRETE FLOOR; BETWEEN THE TOP METAL RUNNER/TRACK AND THE STRUCTURAL DECK; AND BETWEEN THE METAL STUD AND EXTERIOR CONCRETE WALL.
3. THE CONTRACTOR SHALL MINIMIZE DUST GENERATION AND USE THE METHODOLOGIES OUTLINED IN GARFE FOR DUST PREVENTION AND SUPPRESSION.
4. ALL REMOVALS AND OTHER CLEANING PROCEDURES SHALL BE CONDUCTED AT NIGHT BETWEEN THE HOURS OF 10:00 PM AND 6:00 AM. NEGATIVE AIR PRESSURE EQUIPMENT SHALL BE EQUIPPED WITH A HEPA FILTER AND DISCHARGED OUTSIDE OF THE BUILDING WHENEVER POSSIBLE, OTHERWISE DISCHARGED THROUGH A SECOND HEPA FILTER IN ORDER TO PERMIT RECIRCULATION OF AIR INSIDE THE BUILDING.
5. ONCE THE MOLD HAS BEEN REMOVED AND CLEARANCE HAS BEEN ACHIEVED, AND THE STAINED SURFACES HAVE BEEN CLEANED, THEN REMOVE ALL PARTITION WALLS, DOORS AND DOOR FRAMES, EXCEPT THOSE AROUND THE ELEVATOR CORE AND STARWELL.
6. CUT A 1/2" GAP BETWEEN THE BOTTOM OF THE GYPSUM BOARD AND CONCRETE DECK. FILL THE GAP WITH A 2-HR FIRE-RATED CAULK IN THE REMAINING PARTITION WALLS AROUND THE ELEVATOR CORE AND STARWELL CORRIDOR.
7. PAINT ELEVATOR CORE EXTERIOR AND STARWELL CORRIDOR WITH MOLD RESISTANT PAINT.
8. FURNISH AND INSTALL FIRE-RATED ACCESS PANELS IN THE CENTER OF THE NORTH AND EAST ELEVATOR CORE WALL. THE BOTTOM OF THE PANEL SHALL BE 2" ABOVE THE FLOOR. DO NOT PENETRATE THE SHAFT LINER. SEE DETAIL "B" ON DWG DTW-D-ATCT-AH.

ROOM 527

1. A MINICONTAINMENT SHALL BE ESTABLISHED CONSISTING OF A SINGLE LAYER OF 6-MIL POLYETHYLENE SHEETING BUT A NEGATIVE PRESSURE ENCLOSURE SYSTEM IS NOT REQUIRED. MUST ANY CONTAMINATED AREAS PRIOR TO REMOVAL. UPON COMPLETION, THE WORK AREA SHALL BE HEPA VACUUMED AND THEN WET WIPED WITH A DETERGENT SOLUTION.
2. CLEANUP AND REMOVAL OF MOISTURE AND MICROBIOLOGICAL CONTAMINATED GYPSUM BOARD, SHAFT LINER, AND INSULATION IN ACCORDANCE WITH THE GUIDELINES ESTABLISHED BY THE NEW YORK CITY DEPARTMENT OF HEALTH ENTITLED GUIDELINES ON ASSESSMENT AND REMEDIATION OF FUNGUS INDOOR ENVIRONMENTS (GARFE) (SEE SPECIFICATION ATTACHMENT II).
3. APPROXIMATELY 4 LINEAR FEET OF 1" AND 25 LINEAR FEET OF 1/2" WATER STAINED AND/OR CONTAMINATED CHILLED AND HEATING WATER PIPE INSULATION SHALL BE REMOVED AND REPLACED.
4. REMOVE GYPSUM BOARD AND INSULATION TOTALING APPROXIMATELY 15 SQUARE FEET, ON THE NORTH WALL, BETWEEN THE EAST WALL AND THE DOOR TO ROOM 527A. 2" WIDE TO A HEIGHT OF 4" (SURFACE LAYER) AND 2" WIDE TO A HEIGHT OF 3/8" (CONCEALED LAYER).

ROOM 527A

1. A MINICONTAINMENT SHALL BE ESTABLISHED CONSISTING OF A SINGLE LAYER OF 6-MIL POLYETHYLENE SHEETING BUT A NEGATIVE PRESSURE ENCLOSURE SYSTEM IS NOT REQUIRED. MUST ANY CONTAMINATED AREAS PRIOR TO REMOVAL. UPON COMPLETION, THE WORK AREA SHALL BE HEPA VACUUMED AND THEN WET WIPED WITH A DETERGENT SOLUTION.
2. CLEANUP AND REMOVAL OF MOISTURE AND MICROBIOLOGICAL CONTAMINATED GYPSUM BOARD, SHAFT LINER, AND INSULATION IN ACCORDANCE WITH THE GUIDELINES ESTABLISHED BY THE NEW YORK CITY DEPARTMENT OF HEALTH ENTITLED GUIDELINES ON ASSESSMENT AND REMEDIATION OF FUNGUS INDOOR ENVIRONMENTS (GARFE) (SEE SPEC. ATTACHMENT II).
3. REMOVE GYPSUM BOARD AND INSULATION TOTALING APPROXIMATELY 5 SQUARE FEET, BETWEEN THE EAST WALL AND THE DOOR TO ROOM 527. 2" WIDE TO A HEIGHT OF 8" (SURFACE LAYER) AND 2" WIDE TO A HEIGHT OF 12" (CONCEALED LAYER).

ROOM 529

1. A MINICONTAINMENT SHALL BE ESTABLISHED CONSISTING OF A SINGLE LAYER OF 6-MIL POLYETHYLENE SHEETING. A NEGATIVE PRESSURE ENCLOSURE SYSTEM SHALL BE ESTABLISHED AS DESCRIBED IN SECTION 0909 REMEDIATION AREA.
2. THE PORTION OF THE EAST WALL, BETWEEN THE SOUTH WALL AND STARWELL DOORFRAME, 2" WIDE TO A HEIGHT OF 8", SHALL BE HEPA VACUUMED AND THEN WET WIPED WITH AN APPROVED CLEANING SOLUTION.

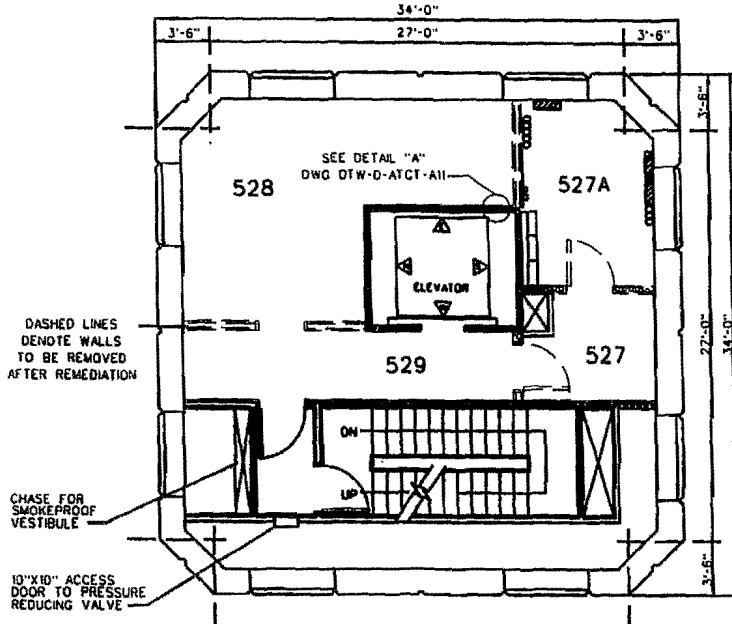

FIFTH FLOOR SHAFT PLAN

SCALE: 1/4" = 1'-0"

| | |
|---|---------------------|
| DEPARTMENT OF LABORATORIES FEDERAL AVIATION ADMINISTRATION | |
| PROJECT: 5TH FLOOR | PROJECT NUMBER: |
| MOISTURE DAMAGE REMEDIATION | |
| 5TH FLOOR | |
| AICT | |
| DETROIT METRO WAYNE COUNTY AIRPORT | |
| DETROIT, MICHIGAN | |
| DATE: 08/08/08 | BY: [Signature] |
| PROJECT: 5TH FL. MOISTURE DAMAGE | DWG: 5TH-0-ATCT-000 |
| DATE: 08/08/08 | BY: [Signature] |

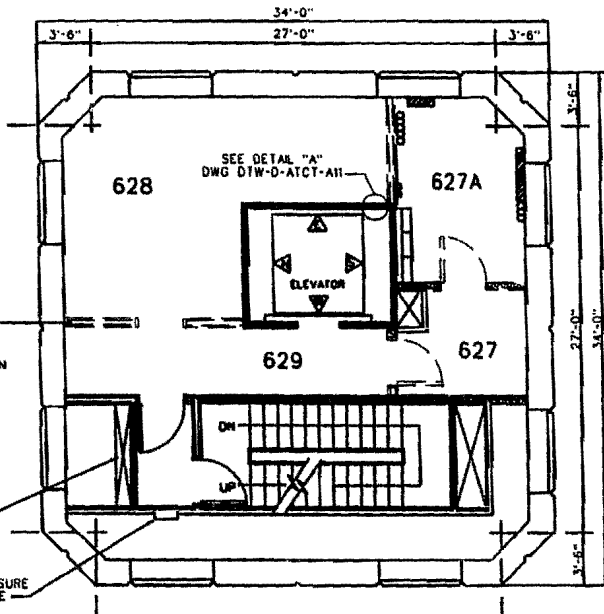

SIXTH FLOOR SHAFT PLAN

NOT TO SCALE

FLOOR 6:

1. PRIOR TO PERFORMING MICROBIOLOGICAL REMEDIATION PROCEDURES, THE CONTRACTOR SHALL SEAL ALL CRITICAL PENETRATIONS AND OPENINGS TO THE WORK AREA WITH A MINIMUM OF TWO LAYERS OF 6-MIL POLYETHYLENE, AND SHALL BE RESPONSIBLE FOR ENSURING ADJOINING AREAS ARE NOT EXPOSED TO THE MICROBIOLOGICAL CONTAMINATION DURING THE REMEDIATION.

2. REMOVE ANY MCM BETWEEN THE BOTTOM METAL RUNNER/TRACK AND THE CONCRETE FLOOR BETWEEN THE TOP METAL RUNNER/ TRACK AND THE STRUCTURAL DECK; AND BETWEEN THE METAL STUD AND EXTERIOR CONCRETE WALL.

3. THE CONTRACTOR SHALL MINIMIZE DUST GENERATION AND USE THE METHODOLOGIES OUTLINED IN GARFIE FOR DUST PREVENTION AND SUPPRESSION.

4. ALL REMOVALS AND OTHER CLEANING PROCEDURES SHALL BE CONDUCTED AT NIGHT BETWEEN THE HOURS OF 11:00 PM AND 6:00 AM. NEGATIVE AIR PRESSURE EQUIPMENT SHALL BE EQUIPPED WITH A HEPA FILTER AND DISCHARGED OUTSIDE OF THE BUILDING WHENEVER POSSIBLE, OTHERWISE DISCHARGED THROUGH A SECOND HEPA FILTER IN ORDER TO PERMIT REDCIRCULATION OF AIR INSIDE THE BUILDING.

5. ONCE THE MOLD HAS BEEN REMOVED AND CLEARANCE HAS BEEN ACHIEVED, AND THE STAINED SURFACES HAVE BEEN CLEANED, THEN REMOVE ALL PARTITION WALLS, DOORS AND DOOR FRAMES, EXCEPT THOSE AROUND THE ELEVATOR CORE AND STARWELL.

6. CUT A 1/2" GAP BETWEEN THE BOTTOM OF THE GYPSUM BOARD AND CONCRETE DECK. FILL THE GAP WITH A 2-HR FIRE-RATED CAULK IN THE REMAINING PARTITION WALLS AROUND THE ELEVATOR CORE AND STARWELL CORRIDOR.

7. PAINT ELEVATOR CORE EXTERIOR AND STARWELL CORRIDOR WITH MOLD RESISTANT PAINT.

8. FURNISH AND INSTALL FIRE-RATED ACCESS PANELS IN THE CENTER OF THE NORTH AND EAST ELEVATOR CORE WALL. THE BOTTOM OF THE PANEL SHALL BE 24" ABOVE THE FLOOR. DO NOT PENETRATE THE SHAFT LINER. SEE DETAIL "B" ON DWG DTW-D-ATCT-A11.

SCOPE OF WORK

ROOM 627

1. THE CONTRACTOR SHALL PROVIDE ADDITIONAL CLEANING PROCEDURES AND PIPE INSULATION REMOVAL/REPLACEMENT.

2. APPROXIMATELY 20 LINEAR FEET OF 1" AND 25 LINEAR FEET OF 1/2" WATER STAINED AND/OR CONTAMINATED CHILLED AND HEATING WATER PIPE INSULATION SHALL BE REMOVED AND REPLACED.

ROOM 628

1. A MMR CONTAINMENT SHALL BE ESTABLISHED CONSISTING OF A SINGLE LAYER OF 6-MIL POLYETHYLENE SHEETING. A NEGATIVE PRESSURE ENCLOSURE SYSTEM SHALL BE ESTABLISHED AS DESCRIBED IN SECTION 18.9 REMEDIATION AREA.

2. THE EAST (ELEVATOR SHAFT) WALL, UP TO A HEIGHT OF 4', SHALL BE HEPA VACUUMED AND THEN WET WIPED WITH AN APPROVED CLEANING SOLUTION.

3. THE SOUTH (ELEVATOR SHAFT) WALL, UP TO A HEIGHT OF 4', SHALL BE HEPA VACUUMED AND THEN WET WIPED WITH AN APPROVED CLEANING SOLUTION.

| | | |
|--|-----|-----------|
| DEPARTMENT OF TRANSPORTATION FLORIDA AIRPORT ADMINISTRATION | | 0300.SURS |
| 01 | 02 | 03 |
| MOISTURE DAMAGE REMEDIATION 6TH FLOOR | | |
| DETROIT METRO WAYNE COUNTY AIRPORT DETROIT, MICHIGAN | | |
| 04 | 05 | 06 |
| 07 | 08 | 09 |
| 10 | 11 | 12 |
| 13 | 14 | 15 |
| 16 | 17 | 18 |
| 19 | 20 | 21 |
| 22 | 23 | 24 |
| 25 | 26 | 27 |
| 28 | 29 | 30 |
| 31 | 32 | 33 |
| 34 | 35 | 36 |
| 37 | 38 | 39 |
| 40 | 41 | 42 |
| 43 | 44 | 45 |
| 46 | 47 | 48 |
| 49 | 50 | 51 |
| 52 | 53 | 54 |
| 55 | 56 | 57 |
| 58 | 59 | 60 |
| 61 | 62 | 63 |
| 64 | 65 | 66 |
| 67 | 68 | 69 |
| 70 | 71 | 72 |
| 73 | 74 | 75 |
| 76 | 77 | 78 |
| 79 | 80 | 81 |
| 82 | 83 | 84 |
| 85 | 86 | 87 |
| 88 | 89 | 90 |
| 91 | 92 | 93 |
| 94 | 95 | 96 |
| 97 | 98 | 99 |
| 100 | 101 | 102 |

SCOPE OF WORK

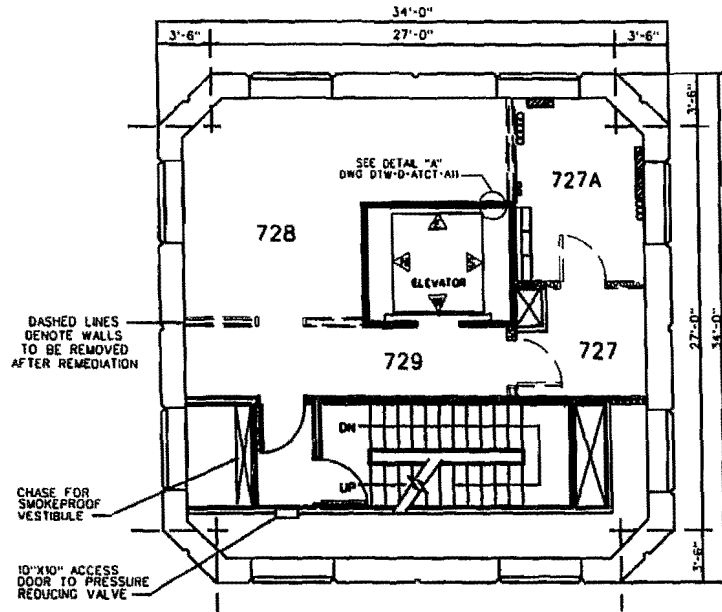

SEVENTH FLOOR SHAFT PLAN

NOT TO SCALE

FLOOR 7:

1. PRIOR TO PERFORMING MICROBIOLOGICAL REMEDIATION PROCEDURES, THE CONTRACTOR SHALL SEAL ALL CRITICAL PENETRATIONS AND OPENINGS TO THE WORK AREA WITH A MINIMUM OF TWO LAYERS OF 6-MIL POLYETHYLENE, AND SHALL BE RESPONSIBLE FOR ENSURING ADJOINING AREAS ARE NOT EXPOSED TO THE MICROBIOLOGICAL CONTAMINATION DURING THE REMEDIATION.
2. REMOVE ANY MCM BETWEEN THE BOTTOM METAL RUNNER/TRACK AND THE CONCRETE FLOOR; BETWEEN THE TOP METAL RUNNER/ TRACK AND THE STRUCTURAL DECK; AND BETWEEN THE METAL STUD AND EXTERIOR CONCRETE WALL.
3. THE CONTRACTOR SHALL MINIMIZE DUST GENERATION AND USE THE METHODOLOGIES OUTLINED IN CARFIC FOR DUST PREVENTION AND SUPPRESSION.
4. ALL REMOVALS AND OTHER CLEANING PROCEDURES SHALL BE CONDUCTED AT NIGHT BETWEEN THE HOURS OF 10:00 PM AND 6:00 AM. NEGATIVE AIR PRESSURE EQUIPMENT SHALL BE EQUIPPED WITH A HEPA FILTER AND DISCHARGED OUTSIDE OF THE BUILDING WHENEVER POSSIBLE, OTHERWISE DISCHARGED THROUGH A SECOND HEPA FILTER IN ORDER TO PERMIT RECIRCULATION OF AIR INSIDE THE BUILDING.
5. ONCE THE MOLD HAS BEEN REMOVED AND CLEARANCE HAS BEEN ACHIEVED, AND THE STAINED SURFACES HAVE BEEN CLEANED, THEN REMOVE ALL PARTITION WALLS, DOORS AND DOOR FRAMES, EXCEPT THOSE AROUND THE ELEVATOR CORE AND STAIRWELL.
6. CUT A 1/2" GAP BETWEEN THE BOTTOM OF THE GYPSUM BOARD AND CONCRETE DECK. FILL THE GAP WITH A 2-HR FIRE-RATED CALK IN THE REMAINING PARTITION WALLS AROUND THE ELEVATOR CORE AND STAIRWELL CORRIDOR.
7. PAINT ELEVATOR CORE EXTERIOR AND STAIRWELL CORRIDOR WITH MOLD RESISTANT PAINT.
8. FURNISH AND INSTALL FIRE-RATED ACCESS PANELS IN THE CENTER OF THE NORTH AND EAST ELEVATOR CORE WALL. THE BOTTOM OF THE PANEL SHALL BE 24" ABOVE THE FLOOR. DO NOT PENETRATE THE SHAFT LINER. SEE DETAIL "B" ON DWG DTW-D-ATCT-A11.

ROOM 727

1. THE CONTRACTOR SHALL PROVIDE ADDITIONAL CLEANING PROCEDURES AND PIPE INSULATION REMOVAL/ REPLACEMENT.
2. APPROXIMATELY 3 LINEAR FEET OF 18" WATER STAINED AND/OR CONTAMINATED CHILLED AND HEATING WATER PIPE INSULATION SHALL BE REMOVED AND REPLACED.

ROOM 727A

1. A MINICONTAINMENT SHALL BE ESTABLISHED CONSISTING OF A SINGLE LAYER OF 6-MIL POLYETHYLENE SHEETING. A NEGATIVE PRESSURE ENCLOSURE SYSTEM SHALL BE ESTABLISHED AS DESCRIBED IN SECTION 10.9 REMEDIATION AREA.
2. THE PORTION OF THE WEST WALL BETWEEN THE CABLE TRAY AND THE NORTH WALL, UP TO A HEIGHT OF 4', SHALL BE HEPA VACUUMED AND THEN WET WIPED WITH AN APPROVED CLEANING SOLUTION.
3. THE SOUTH WALL ABOVE THE DOOR TO ROOM 727, 3' WIDE TO A HEIGHT OF 3', SHALL BE HEPA VACUUMED AND THEN WET WIPED WITH AN APPROVED CLEANING SOLUTION.

ROOM 728

1. A MINICONTAINMENT SHALL BE ESTABLISHED CONSISTING OF A SINGLE LAYER OF 6-MIL POLYETHYLENE SHEETING. A NEGATIVE PRESSURE ENCLOSURE SYSTEM SHALL BE ESTABLISHED AS DESCRIBED IN SECTION 10.9 REMEDIATION AREA.
2. THE EAST (ELEVATOR SHAFT) WALL, UP TO A HEIGHT OF 4', SHALL BE HEPA VACUUMED AND THEN WET WIPED WITH AN APPROVED CLEANING SOLUTION.
3. THE SOUTH (ELEVATOR SHAFT) WALL, UP TO A HEIGHT OF 4', SHALL BE HEPA VACUUMED AND THEN WET WIPED WITH AN APPROVED CLEANING SOLUTION.

| | |
|------------------------------------|--------------------|
| DEPARTMENT OF TEMPERATURE | |
| FEDERAL AVIATION ADMINISTRATION | |
| ENCLOSURE NO.: | DESCRIPTION: |
| MOISTURE DAMAGE REMEDIATION | |
| 7TH FLOOR | |
| ATCT | |
| DETROIT METRO WAYNE COUNTY AIRPORT | |
| DETROIT, MICHIGAN | |
| DATE: | BY: |
| PROJECT NO.: | ISSUE NO.: |
| PROJECT NAME: | DESCRIPTION: |
| PROJECT LOCATION: | DATE OF ISSUE: |
| PROJECT STATUS: | DATE OF REVIEW: |
| PROJECT OWNER: | DATE OF APPROVAL: |
| PROJECT MANAGER: | DATE OF SIGNATURE: |
| PROJECT SUPERVISOR: | DATE OF SIGNATURE: |
| PROJECT ENGINEER: | DATE OF SIGNATURE: |
| PROJECT ARCHITECT: | DATE OF SIGNATURE: |

SCOPE OF WORK

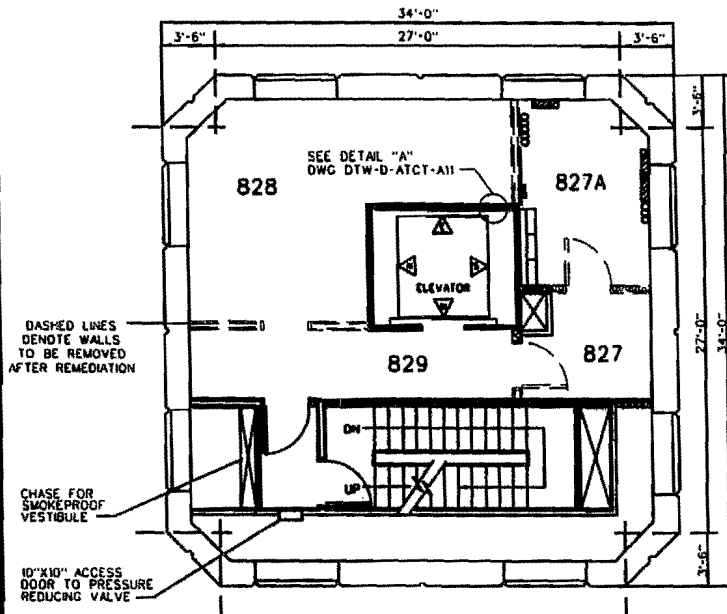

FLOOR 8:

1. PRIOR TO PERFORMING MICROBIOLOGICAL REMEDIATION PROCEDURES, THE CONTRACTOR SHALL SEAL ALL CRITICAL PENETRATIONS AND OPENINGS TO THE WORK AREA WITH A MINIMUM OF TWO LAYERS OF 6-MIL POLYETHYLENE, AND SHALL BE RESPONSIBLE FOR ENSURING ADJOINING AREAS ARE NOT EXPOSED TO THE MICROBIOLOGICAL CONTAMINATION DURING THE REMEDIATION.
2. REMOVE ANY MCM BETWEEN THE BOTTOM METAL RUNNER/TRACK AND THE CONCRETE FLOOR; BETWEEN THE TOP METAL RUNNER/TRACK AND THE STRUCTURAL DECK; AND BETWEEN THE METAL STUD AND EXTERIOR CONCRETE WALL.
3. THE CONTRACTOR SHALL MINIMIZE DUST GENERATION AND USE THE METHODOLOGIES OUTLINED IN GARFIE FOR DUST PREVENTION AND SUPPRESSION.
4. ALL REMOVALS AND OTHER CLEANING PROCEDURES SHALL BE CONDUCTED AT NIGHT BETWEEN THE HOURS OF 11:00 PM AND 6:00 AM. NEGATIVE AIR PRESSURE EQUIPMENT SHALL BE EQUIPPED WITH A HEPA FILTER AND DISCHARGED OUTSIDE OF THE BUILDING WHENEVER POSSIBLE, OTHERWISE DISCHARGED THROUGH A SECOND HEPA FILTER IN ORDER TO PERMIT RECIRCULATION OF AIR INSIDE THE BUILDING.
5. ONCE THE MOLD HAS BEEN REMOVED AND CLEARANCE HAS BEEN ACHIEVED, AND THE STAINED SURFACES HAVE BEEN CLEANED, THEN REMOVE ALL PARTITION WALLS, DOORS AND DOOR FRAMES, EXCEPT THOSE AROUND THE ELEVATOR CORE AND STAIRWELL.
6. CUT A 1/2" GAP BETWEEN THE BOTTOM OF THE GYPSUM BOARD AND CONCRETE DECK. FILL THE GAP WITH A 2-HR FIRE-RATED CAULK IN THE REMAINING PARTITION WALLS AROUND THE ELEVATOR CORE AND STAIRWELL CORRIDOR.
7. PAINT ELEVATOR CORE EXTERIOR AND STAIRWELL CORRIDOR WITH MOLD RESISTANT PAINT.
8. FURNISH AND INSTALL FIRE-RATED ACCESS PANELS IN THE CENTER OF THE NORTH AND EAST ELEVATOR CORE WALL. THE BOTTOM OF THE PANEL SHALL BE 24" ABOVE THE FLOOR. DO NOT PENETRATE THE SHAFT LINER. SEE DETAIL "B" ON DWG DTW-D-ATCT-A11

ROOM 827

1. THE CONTRACTOR SHALL PROVIDE ADDITIONAL CLEANING PROCEDURES AND PIPE INSULATION REMOVAL/REPLACEMENT.
2. APPROXIMATELY 4 LINEAR FEET OF 1" WATER STAINED AND/OR CONTAMINATED CHILLED AND HEATING WATER PIPE INSULATION SHALL BE REMOVED AND REPLACED.

ROOM 829

1. A MINI-CONTAINMENT SHALL BE ESTABLISHED CONSISTING OF A SINGLE LAYER OF 6-MIL POLYETHYLENE SHEETING. A NEGATIVE PRESSURE ENCLOSURE SYSTEM SHALL BE ESTABLISHED AS DESCRIBED IN SECTION 18.9 REMEDIATION AREA.
2. THE PORTION OF THE EAST WALL, BETWEEN THE SOUTH WALL AND STAIRWELL DOORFRAME, 2" WIDE TO A HEIGHT OF 8', SHALL BE HEPA VACUUMED AND THEN WET WIPED WITH AN APPROVED CLEANING SOLUTION.
3. THE ADJACENT SOUTH WALL, FROM THE SOUTHEAST CORNER WESTWARD, 1' WIDE TO A HEIGHT OF 8', SHALL BE HEPA VACUUMED AND THEN WET WIPED WITH AN APPROVED CLEANING SOLUTION.

| | | |
|---|------------------|-----------------|
| DEPARTMENT OF TRANSPORTATION FEDERAL AVIATION ADMINISTRATION | | GENERAL |
| MOISTURE DAMAGE REDUCTION 8TH FLOOR ATCT | | |
| DETROIT MICRO BAYNE COUNTY AIRPORT DETROIT, MICHIGAN | | |
| DATE: 8/8/2008 | TIME: 9:51:38 AM | BY: [Signature] |
| PROJECT: 03G DTW-D-ATCT-8TH FL REM | | SHEET: 01 OF 01 |

SCOPE OF WORK

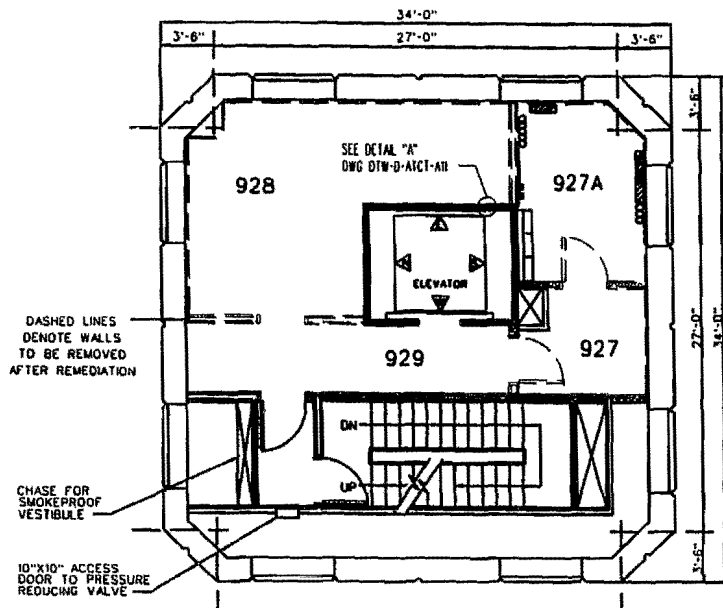

NINTH FLOOR SHAFT PLAN

NOT TO SCALE

FLOOR 9:

1. PRIOR TO PERFORMING MICROBIOLOGICAL REMEDIATION PROCEDURES, THE CONTRACTOR SHALL SEAL ALL CRITICAL PENETRATIONS AND OPENINGS TO THE WORK AREA WITH A MINIMUM OF TWO LAYERS OF 6-MIL POLYETHYLENE, AND SHALL BE RESPONSIBLE FOR ENSURING ADJOINING AREAS ARE NOT EXPOSED TO THE MICROBIOLOGICAL CONTAMINATION DURING THE REMEDIATION.

2. REMOVE ANY MCM BETWEEN THE BOTTOM METAL RUNNER/TRACK AND THE CONCRETE FLOOR; BETWEEN THE TOP METAL RUNNER/TRACK AND THE STRUCTURAL DECK; AND BETWEEN THE METAL STUD AND EXTERIOR CONCRETE WALL.

3. THE CONTRACTOR SHALL MINIMIZE DUST GENERATION AND USE THE METHODOLOGIES OUTLINED IN GARFIE FOR DUST PREVENTION AND SUPPRESSION.

4. ALL REMOVALS AND OTHER CLEANING PROCEDURES SHALL BE CONDUCTED AT NIGHT BETWEEN THE HOURS OF 10:00 PM AND 5:00 AM. NEGATIVE AIR PRESSURE EQUIPMENT SHALL BE EQUIPPED WITH A HEPA FILTER AND DISCHARGED OUTSIDE OF THE BUILDING WHENEVER POSSIBLE, OTHERWISE DISCHARGED THROUGH A SECOND HEPA FILTER IN ORDER TO PERMIT RECIRCULATION OF AIR INSIDE THE BUILDING.

5. ONCE THE MOLD HAS BEEN REMOVED AND CLEARANCE HAS BEEN ACHIEVED, AND THE STAINED SURFACES HAVE BEEN CLEANED, THEN REMOVE ALL PARTITION WALLS, DOORS AND DOOR FRAMES, EXCEPT THOSE AROUND THE ELEVATOR CORE AND STAIRWELL.

6. CUT A 1/2" GAP BETWEEN THE BOTTOM OF THE GYPSUM BOARD AND THE CONCRETE DECK. FILL THE GAP WITH A 2-HR FIRE-RATED CALK IN THE REMAINING PARTITION WALLS AROUND THE ELEVATOR CORE AND STAIRWELL CORRIDOR.

7. PAINT ELEVATOR CORE EXTERIOR AND STAIRWELL CORRIDOR WITH MOLD RESISTANT PAINT.

8. FURNISH AND INSTALL FIRE-RATED ACCESS PANELS IN THE CENTER OF THE NORTH AND EAST ELEVATOR CORE WALL. THE BOTTOM OF THE PANEL SHALL BE 24" ABOVE THE FLOOR. DO NOT PENETRATE THE SHAFT LINER. SEE DETAIL "B" ON DWG DTW-D-ATCT-911.

ROOM 927

1. THE CONTRACTOR SHALL PROVIDE ADDITIONAL CLEANING PROCEDURES AND PIPE INSULATION REMOVAL/REPLACEMENT.

2. APPROXIMATELY 4 LINEAR FEET OF 1" WATER STAINED AND/OR CONTAMINATED CHILLED AND HEATING WATER PIPE INSULATION SHALL BE REMOVED AND REPLACED.

ROOM 928

1. A CONTAINMENT AND NEGATIVE PRESSURE ENCLOSURE SYSTEM SHALL BE ESTABLISHED AS DESCRIBED IN SECTION 18.9 REMEDIATION AREA. A DECONTAMINATION UNIT SHALL BE ESTABLISHED AS DESCRIBED IN SECTION 18.10 DECONTAMINATION.

2. CLEANUP AND REMOVAL OF MOISTURE AND MICROBIOLOGICAL CONTAMINATED GYPSUM BOARD, SHAFT LINER, AND INSULATION IN THE DTW ATCT ROOMS 928, IN ACCORDANCE WITH THE GUIDELINES ESTABLISHED BY THE NEW YORK CITY DEPARTMENT OF HEALTH ENTITLED GUIDELINES ON ASSESSMENT AND REMEDIATION OF FUNGUS INDOOR ENVIRONMENTS (GARFIE) (SEE ATTACHMENT D).

3. REMOVE AND REPLACE GYPSUM BOARD, SHAFT LINER, AND INSULATION TOTALING APPROXIMATELY 311 SQUARE FEET

A. THE EAST (ELEVATOR SHAFT) WALL, 8' WIDE TO A HEIGHT OF 5' (SURFACE LAYER), 8' WIDE TO A HEIGHT OF 4'5" (CONCEALED LAYER), AND 8' WIDE TO A HEIGHT OF 4' (SHAFT LINER).

B. THE SOUTH (ELEVATOR SHAFT) WALL, 10' WIDE TO A HEIGHT OF 5' (SURFACE LAYER), 10' WIDE TO A HEIGHT OF 4'5" (CONCEALED LAYER), AND 10' WIDE TO A HEIGHT OF 4' (SHAFT LINER).

C. THE NORTHWEST COLUMN BEAM ENCLOSURE, ON THE NORTH WALL, 6' WIDE TO A HEIGHT OF 3' (SURFACE LAYER), 6' WIDE TO A HEIGHT OF 2'6" (CONCEALED LAYER), AND 6' WIDE TO A HEIGHT OF 2' (SHAFT LINER).

D. THE WEST WALL, 3' WIDE TO A HEIGHT OF 3' (SURFACE LAYER), 3' WIDE TO A HEIGHT OF 2'6" (CONCEALED LAYER), AND 3' WIDE TO A HEIGHT OF 2' (SHAFT LINER).

E. ELEVATOR SHAFT LINER REMOVAL AND REPLACEMENT REQUIRES COORDINATION WITH THE ELEVATOR MAINTENANCE CO. AND AIR TRAFFIC TO SCHEDULE LIMITED ELEVATOR SHUTDOWN TIME.

| | | |
|---|----------------|--------------|
| DEPARTMENT OF TRANSPORTATION FEDERAL AVIATION ADMINISTRATION | | DATE: 8/1/08 |
| MOISTURE DAMAGE REMEDIATION | | |
| 9TH FLOOR | | |
| ATCT | | |
| DETROIT METRO MARYN COUNTY AIRPORT | | |
| DETROIT, MICHIGAN | | |
| PROJECT NO: | 910-9-ATCT-900 | |
| DATE: | 8/1/08 | |
| BY: | | |
| CHECKED BY: | | |
| SCALE: | | |

SCOPE OF WORK

FLOOR 10:

1. PRIOR TO PERFORMING MICROBIOLOGICAL REMEDIATION PROCEDURES, THE CONTRACTOR SHALL SEAL ALL CRITICAL PENETRATIONS AND OPENINGS TO THE WORK AREA WITH A MINIMUM OF TWO LAYERS OF 6-MIL POLYETHYLENE, AND SHALL BE RESPONSIBLE FOR ENSURING ADJOINING AREAS ARE NOT EXPOSED TO THE MICROBIOLOGICAL CONTAMINATION DURING THE REMEDIATION.
2. REMOVE ANY MCM BETWEEN THE BOTTOM METAL RUNNER/TRACK AND THE CONCRETE FLOOR; BETWEEN THE TOP METAL RUNNER/TRACK AND THE STRUCTURAL DECK; AND BETWEEN THE METAL STUD AND EXTERIOR CONCRETE WALL.
3. THE CONTRACTOR SHALL MINIMIZE DUST GENERATION AND USE THE METHODOLOGIES OUTLINED IN CARFE FOR DUST PREVENTION AND SUPPRESSION.
4. ALL REMOVALS AND OTHER CLEANING PROCEDURES SHALL BE CONDUCTED AT NIGHT BETWEEN THE HOURS OF 11:00 PM AND 6:00 AM. NEGATIVE AIR PRESSURE EQUIPMENT SHALL BE EQUIPPED WITH A HEPA FILTER AND DISCHARGED OUTSIDE OF THE BUILDING. WHENEVER POSSIBLE, OTHERWISE DISCHARGED THROUGH A SECOND HEPA FILTER IN ORDER TO PERMIT RECIRCULATION OF AIR INSIDE THE BUILDING.
5. ONCE THE MOLD HAS BEEN REMOVED AND CLEARANCE HAS BEEN ACHIEVED, AND THE STAINED SURFACES HAVE BEEN CLEANED, THEN REMOVE ALL PARTITION WALLS, DOORS AND DOOR FRAMES EXCEPT THOSE AROUND THE ELEVATOR CORE AND STARWELL.
6. CUT A 1/2" GAP BETWEEN THE BOTTOM OF THE GYPSUM BOARD AND THE CONCRETE DECK. FILL THE GAP WITH A 2-HR FIRE-RATED CAULK IN THE REMAINING PARTITION WALLS AROUND THE ELEVATOR CORE AND STARWELL.
7. PAINT THE ELEVATOR CORE EXTERIOR AND STARWELL CORRIDOR WITH MOLD RESISTANT PAINT.
8. FURNISH AND INSTALL FIRE-RATED ACCESS PANELS IN THE CENTER OF THE NORTH AND EAST ELEVATOR CORE WALL. THE BOTTOM OF THE PANEL SHALL BE 24" ABOVE THE FLOOR. DO NOT PENETRATE SHAFT LINER. SEE DETAIL "B" ON DWG DTW-D-ATCT-AH.

ROOM 1028

1. A CONTAINMENT AND NEGATIVE PRESSURE ENCLOSURE SYSTEM SHALL BE ESTABLISHED AS DESCRIBED IN SECTION 18.9 REMEDIATION AREA. A DECONTAMINATION UNIT SHALL BE ESTABLISHED AS DESCRIBED IN SECTION 18.10 DECONTAMINATION AREA.
2. CLEANUP AND REMOVAL OF MOISTURE AND MICROBIOLOGICAL CONTAMINATED GYPSUM BOARD, SHAFT LINER, AND INSULATION IN THE DTW ATCT ROOM 1028, IN ACCORDANCE WITH THE GUIDELINES ESTABLISHED BY THE NEW YORK CITY DEPARTMENT OF HEALTH ENTITLED GUIDELINES ON ASSESSMENT AND REMEDIATION OF FUNGI IN INDOOR ENVIRONMENTS (GARFE) ATTACHED AND INCORPORATED HEREIN BY REFERENCE (SEE ATTACHMENT 1).
3. THE NORTH WALL SHAFT LINER IN ITS ENTIRETY SHALL BE HEPA VACUUMED AND THEN WET WIPED WITH AN APPROVED CLEANING SOLUTION.
4. REMOVE AND DISPOSE OF EXISTING CARPET.
5. REMOVE AND REPLACE GYPSUM BOARD, SHAFT LINER, AND INSULATION TOTALING 792 SQUARE FEET. THE NORTH ELEVATOR SHAFT WALL, 22" WIDE FOR THE FULL HEIGHT, (SURFACE LAYER, CONCEALED LAYER AND SHAFT LINER).

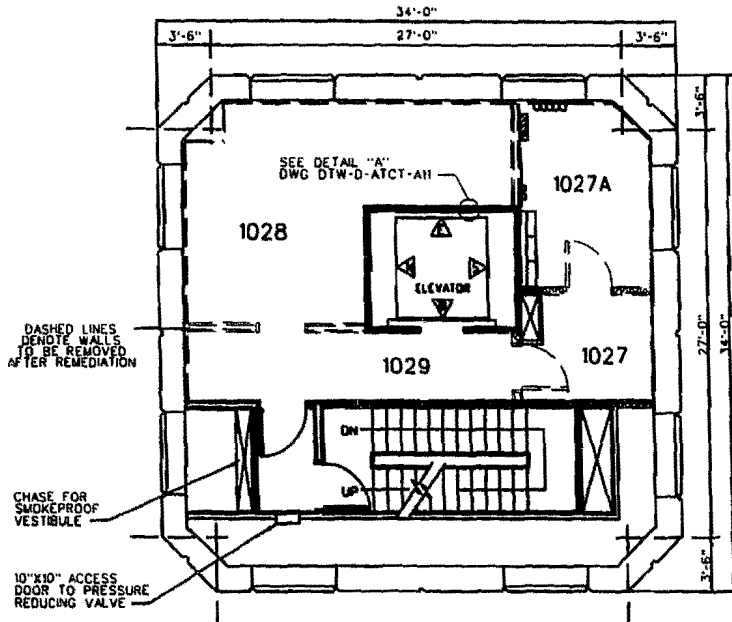

TENTH FLOOR SHAFT PLAN

NOT TO SCALE

| | | | |
|---|-----------------------------|----------|----------------------|
| DEPARTMENT OF TRANSPORTATION FEDERAL AVIATION ADMINISTRATION | | | |
| PROJECT NO. 03-01-0000-0000-0000 | | | |
| MOISTURE DAMAGE REMEDIATION 10TH FLOOR A1C1 | | | |
| DETROIT METRO WAYNE COUNTY AIRPORT DETROIT, MICHIGAN | | | |
| NO. 01 | DESCRIPTION | DATE | BY |
| 01 | MOISTURE DAMAGE REMEDIATION | 08/08/08 | 03-01-0000-0000-0000 |
| 02 | MOISTURE DAMAGE REMEDIATION | 08/08/08 | 03-01-0000-0000-0000 |
| 03 | MOISTURE DAMAGE REMEDIATION | 08/08/08 | 03-01-0000-0000-0000 |
| 04 | MOISTURE DAMAGE REMEDIATION | 08/08/08 | 03-01-0000-0000-0000 |

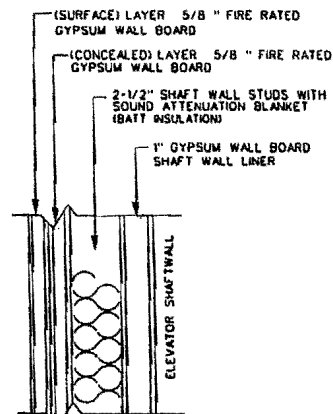

THERE SHALL BE A 1/2" GAP BETWEEN THE BOTTOM OF THE GYPSUM BOARD AND THE CONCRETE DECK. THE GAP SHALL BE FILLED WITH A 2-HR FIRE-RATED CAULK

DETAIL A - PARTITION WALL
(2 HOUR FIRE RATING)
NOT TO SCALE

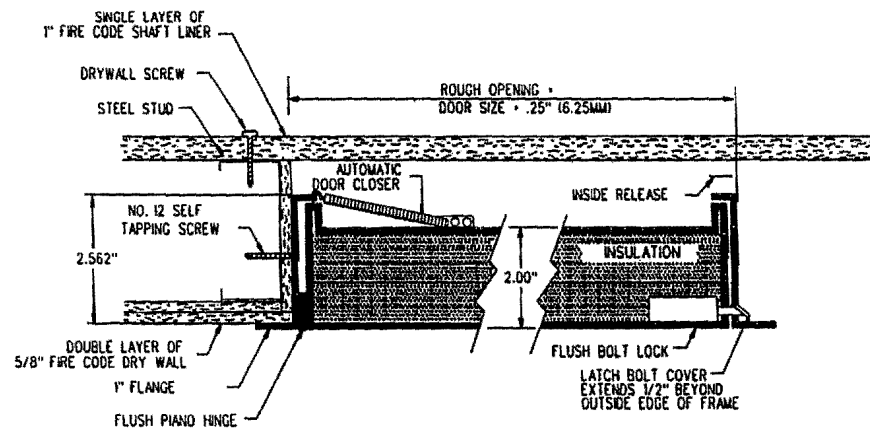

A CUT THROUGH SECTION
A NOT TO SCALE

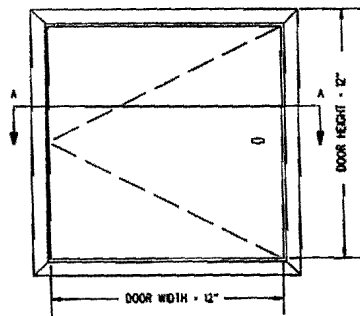

FRONT ELEVATION
NOT TO SCALE

DETAIL B - INSULATED FIRE RATED ACCESS PANEL FOR WALLS

(1 1/2 HOUR FIRE RATING)
NOT TO SCALE

| | | |
|---|----|---------------|
| DEPARTMENT OF TRANSPORTATION FEDERAL AVIATION ADMINISTRATION | | DESIGN NUMBER |
| PROJECT NUMBER | | REVISION |
| MOISTURE DAMAGE REMEDIATION | | |
| DETAILS | | |
| ATCT | | |
| DETROIT METRO WAYNE COUNTY AIRPORT | | |
| DETROIT, MICHIGAN | | |
| DATE | BY | CHK'D BY |
| | | |
| | | |
| | | |
| | | |
| | | |
| | | |
| | | |
| | | |

ENGINEERING COST ESTIMATE

DATE PREPARED

8/7/2008

SHEET 1 OF 1

| | | | | | |
|------------------|--|----------------|--|--|--|
| PROJECT | | Remediation | | BASIS FOR ESTIMATE | |
| LOCATION | | DTW ATCT | | <input type="checkbox"/> PROJECT DESIGN <input checked="" type="checkbox"/> STANDARD DESIGN <input type="checkbox"/> OTHER (SPECIFY) | |
| DRAWING REF. NO. | | SPEC. REF. NO. | | <input type="checkbox"/> GOVERNMENT ESTIMATE | |

| | | | | |
|-----------------------------|--------------------------|-----------|----------|------------|
| PREPARING ORGANIZATION UNIT | AGL-473B | ESTIMATOR | D. Morse | CHECKED BY |
| CLASS OF WORK | Environmental/Structural | | | |

| ITEM | QUANTITY | | MATERIAL COST-\$ | | LABOR COST-\$ | | EQUIPMENT COST-\$ | | TOTAL ITEM COST-\$ |
|------------------------------------|------------|-----------|------------------|-------------|---------------|-------------|-------------------|----------|--------------------|
| | UNIT MEAS. | NO. UNITS | PER UNIT | TOTAL | PER UNIT | TOTAL | PER UNIT | TOTAL | |
| Remediation | | | | | | | | | |
| Demolition | SF | 4869.00 | \$0.10 | \$486.90 | \$0.25 | \$1,217.25 | | \$0.00 | \$1,704.15 |
| Drywall Installation 5/8" | SF | 275.00 | \$1.08 | \$297.00 | \$2.59 | \$712.25 | | \$0.00 | \$1,009.25 |
| Drywall Installation 1" | SF | 200.00 | \$1.38 | \$276.00 | \$3.16 | \$632.00 | | \$0.00 | \$908.00 |
| Batt Insulation | SF | 125.00 | \$0.45 | \$56.25 | \$0.35 | \$43.75 | | \$0.00 | \$100.00 |
| Pipe insulation removal | LF | 100.00 | \$0.93 | \$93.00 | \$13.05 | \$1,305.00 | | \$0.00 | \$1,398.00 |
| Pipe Insulation replacement 11" | LF | 40.00 | \$0.93 | \$37.20 | \$0.70 | \$28.00 | | \$0.00 | \$65.20 |
| Pipe Insulation replacement 18" | LF | 60.00 | \$0.93 | \$55.80 | \$0.70 | \$42.00 | | \$0.00 | \$97.80 |
| Surface wipe and HEPA vac | SF | 500.00 | \$0.10 | \$50.00 | \$0.42 | \$210.00 | \$0.10 | \$50.00 | \$310.00 |
| Mini Containment | SF | 1300.00 | \$4.00 | \$5,200.00 | \$3.00 | \$3,900.00 | | \$0.00 | \$9,100.00 |
| Full Containment | SF | 2200.00 | \$7.00 | \$15,400.00 | \$10.00 | \$22,000.00 | | | \$37,400.00 |
| Paint | SF | 3568.00 | \$0.00 | \$0.00 | \$0.00 | \$0.00 | | | \$0.00 |
| Fire-Rated Caulk | LF | 775.00 | \$0.50 | \$387.50 | \$1.25 | \$968.75 | | | \$1,356.25 |
| Insulated Fire Rated Access Panels | EA | 14.00 | \$150.00 | \$2,100.00 | \$30.00 | \$420.00 | | | \$2,520.00 |
| Replace outlet face plates | EA | 20.00 | \$0.75 | \$15.00 | \$0.30 | \$6.00 | | \$0.00 | \$21.00 |
| Clear debris bags | ROLL | 2.00 | \$40.00 | \$80.00 | | \$0.00 | | \$0.00 | \$80.00 |
| Mobilization | EA | 1.00 | | \$0.00 | \$1,500.00 | \$1,500.00 | | \$0.00 | \$1,500.00 |
| Dumpster | EA | 2.00 | \$1,000.00 | \$2,000.00 | \$500.00 | \$1,000.00 | | \$0.00 | \$3,000.00 |
| Elevator Technician | HR | 16.00 | | \$0.00 | \$25.00 | \$400.00 | | \$0.00 | \$400.00 |
| Supervisor | HR | 40.00 | | \$0.00 | \$87.60 | \$3,504.00 | | \$0.00 | \$3,504.00 |
| Crew | HR | 40.00 | | \$0.00 | \$82.80 | \$3,312.00 | | \$0.00 | \$3,312.00 |
| Duct Tape | ROLL | 10.00 | \$10.00 | \$100.00 | | \$0.00 | | \$0.00 | \$100.00 |
| Negative air machine w/ filter | DAY | 5.00 | | \$0.00 | | \$0.00 | \$100.00 | \$500.00 | \$500.00 |
| Dehumidifier | DAY | 5.00 | | \$0.00 | | \$0.00 | \$35.00 | \$175.00 | \$175.00 |
| HEPA vac | DAY | 5.00 | | \$0.00 | | \$0.00 | \$30.00 | \$150.00 | \$150.00 |
| SUBTOTAL = \$ | | | | | | | | | 68,710.65 |
| Night Differential 25% | | | | | | | | | 17,177.66 |
| OH&P 25% | | | | | | | | | 21,472.08 |
| TOTAL = \$ | | | | | | | | | 107,360.39 |

APPENDIX 1. FORM 3900-8, FAA PRE-CONSTRUCTION AND MAINTENANCE PROJECT SAFETY AND HEALTH CHECKLIST

Purpose

This checklist is intended to be used as a tool by RE/COTRs, designated facility POCs, or SSC managers who oversee construction and maintenance activities that potentially have Occupational Safety, Health, and Environmental (OSH/E) related impacts on AT/AF operations. This tool shall be used, as appropriate, during critical phases of construction and maintenance activities (e.g. the pre-construction meeting, 30-60 days prior to commencement of work, weekly/daily construction meetings, etc.). Emphasis should be placed on using this checklist as a tool to assess as well as reassess hazards as the project progresses.

Specifically, this checklist is intended to:

- Promote sensitivity to potential OSH/E hazards associated with projects and stress the importance of not disrupting NAS operations
- Assist in identifying and validating potential project hazards and associated risks
- Assist in preventing safety and health incidents/accidents and facility shutdowns
- Ensure appropriate contractor measures and controls are in place to address potential project hazards
- Facilitate discussion with the contractor regarding plans to prevent/minimize potential incidents/accidents
- Enhance coordination between OSH/E professionals, project personnel and contractors
- Facilitate review of critical FAA OSH/E procedures with contractors
- Raise OSH/E awareness

- This checklist relies on the training and professional judgment of the user. OSH/E personnel should be consulted as needed.

- A facility POC with a thorough understanding of facility procedures and equipment considerations should participate in the site walk-through.

NOTE: For small procurements (e.g. credit card purchases) and internal FAA projects (e.g. field maintenance party projects), without specifications, immediately contact the designated OSH/E professional for assistance in completing this checklist.

1 Project Summary Information

Fill in the requested site specific information.

| | | | |
|--------------------------------------|---|-------------|---------------------|
| Project Name and Description: | Microbiological Remediation DTW ATCT, Detroit, Michigan | | |
| Project/Activity/Task: | Moisture Damage Remediation | | |
| Planned Start: | TBD | | |
| Expected Completion Date: | Within 30 Calendar Days | | |
| Contractor Contact: | Name: | | Phone: |
| OSH/E Contact: | Name: | Musa Abuzir | Phone: 734-487-7323 |
| Facility POC: | Name: | | Phone: |

2 Facility Procedures

Review site specific FAA procedures and considerations with the contractor. For example, discuss when or how during the project, emergency plans will be used/required. After the procedures have been reviewed, perform a site walk-through with the contractor.

| Facility Procedures | Reviewed? | | | Notes |
|---|-----------|-----|------|-------|
| | Yes | N/A | No * | |
| Asbestos Contingency Plan | | x | | |
| Critical Power Systems Awareness | | x | | |
| Lock Out/Tag Out | | x | | |
| Work Permits (e.g. Asbestos, Lead) | | x | | |
| Emergency Plans (e.g. Occupant Emergency Plan) | x | | | |
| Impacts to Fire Alarm and Suppression Systems | x | | | |
| Site Walk-Through (With Facility POC & Contractor(s)) | x | | | |
| Hazard Communications (e.g. MSDSs) | x | | | |
| Other (e.g. Access/Security/Communications Equip.) | x | | | |

3 Project Hazard/Risk Analysis

Think about your project and its potential hazards and risks. Consider sensitive NAS operations and all facility personnel that may be impacted by your projects. As an example: Construction activities with potential for impacting asbestos materials in or near sensitive operations could result in incidents which disrupt NAS operations. For each potential project hazard indicate (with a checkmark) a level of potential risk for exposure/release/incident.

| Potential Project Hazards | Level of Potential Risk For Exposure/Release/Incident* | | | Notes |
|--|--|-----|-----|-------|
| | High | Low | N/A | |
| Consider Sensitive AT/AF Operations: | | | | |
| Hazardous Substances and Environmental Controls | | | | |
| Asbestos (e.g. Tiles & Insulation) | | | X | |
| Chemical, Gas, Fumes, Dust, Radiation | X | | | |
| Indoor Air | X | | | |
| Ventilation System | | | X | |
| Lead-based Paint | | | X | |
| Electrical Power Systems | | | X | |
| Pressurized Equipment and Systems | | X | | |
| Work at Heights (>6 feet) | | X | | |
| Other (e.g. Confined Space) | | X | | |

4 Site Safety and Health

After reviewing the potential hazards and risks in block 3, ensure that the contractor has identified measures and controls to address applicable site safety and health risks (e.g. through discussions, available site safety plans, or other applicable documents). In your judgment, if the contractor has appropriate measures to address the potential project hazards (see block 3), check the appropriate YES boxes below. If a potential project hazard has been identified in block 3 and no associated measures or controls are evident, then check the appropriate NO boxes below. If a NO box is checked, use the close-out date box to indicate when appropriate measures or controls have been incorporated into the contractor's site safety and health approach.

| Program Elements | Yes | N/A | No* | If No, Indicate Close-out Date | Notes |
|---|-----|-----|-----|--------------------------------|----------|
| Hazardous Substances & Environmental Controls | | | | | |
| Asbestos | | X | | | |
| Chemicals (e.g. Introduced to site)(Provide MSDS) | X | | | | |
| Gas | | X | | | |
| Fumes | | X | | | |
| Lead Paint/Other Coatings | | X | | | |
| Radiation and Electric Fields | | X | | | |
| Ventilation and Exhaust Systems | | X | | | |
| Electrical Power Systems | | | | | |
| Procedures for Critical Power Systems Coordination | | X | | | |
| Provisions for GFCI | | X | | | |
| Control of Hazardous Energy (Lockout/Tagout) (e.g. Electrical, Mechanical, Hydraulic, Thermal, Radiation) | X | | | | Elevator |
| Pressurized Equipment and Systems | | | | | |
| Work at Heights (>6 feet) | | | | | |
| Safe Access and Fall Protection | X | | | | |
| Work Platforms | X | | | | |
| Floor and Wall Holes and Openings | x | | | | |
| Personal Protective and Safety Equipment | X | | | | |
| Fire Prevention | X | | | | |
| Accident Prevention | X | | | | |
| Excavations (New Construction or Tie in) | | X | | | |
| Welding and Cutting | | X | | | |
| Demolition of Existing Facility in Whole or Part | X | | | | |
| Medical and First Aid Requirements | X | | | | |
| Hand and Power Tools | X | | | | |
| Material Handling, Storage, and Disposal | X | | | | |
| Rigging | | X | | | |
| Machinery and Mechanized Equipment (e.g. Equipment & Operator Certifications) | X | | | | |
| Sanitation | | X | | | |
| Lighting | | X | | | |
| Concrete & Masonry Construction & Steel Erection | | X | | | |
| Hazardous, Toxic, Radioactive Waste Activities | | X | | | |
| Other (e.g. Noise) | X | | | | |

5 Review Information

The appropriate FAA point of contact and the contractor shall sign below to document discussion of the items on this form.

| | |
|--|--|
| Reviewed By: | Date |
| FAA POC: | |
| Contractor: | |
| Incident Prevention and Hazard Control Methods Discussed? | Yes <input type="checkbox"/> No <input type="checkbox"/> |

This block indicates routing of this checklist for project coordination.

| This form has been forwarded to: | Name | Date |
|----------------------------------|------|------|
| SECM, OSH/E Contact: | | |
| AF Facility Manager: | | |
| AT Facility Manager: | | |
| Other: | | |

Notes (e.g. Provide further explanation of potential hazards, locations, etc. below and attach additional sheets if necessary.)

Consult with your SECM or designated OSH/E professional for additional guidance and assistance.

| | | | | | |
|------------------|--|------------------|-----------|--------------------|-----------|
| PROJECT | DTW ATCT Microbiological Remediation | JON | | DATE | 07/18/08 |
| DISTRICT | ZOB | FACILITY | ATCT | FACILITY ID | DTW |
| ENGINEER | D. MORSE | EHS | M. ABUZIR | SUPERVISOR | T. DEMSKE |
| SIGNATURE | | SIGNATURE | | SIGNATURE | |

| Issue | | Yes | N/A | No | Action Items and Notes |
|--|--|-----|----------|----|---|
| AIR EMISSIONS CLEAN AIR ACT (CAA) | Replace and/or install new emission sources such as boilers, incinerators, storage tanks, engine generators, painting booths, space heaters, equipment using CFCs or Halon, etc. Notes: | | X | | <i>If YES, always coordinate with EOSH Specialist</i> 1. Review CAA implementing regulations, 40 CFR Parts 50-53, 60, 61, 63, 68, 70, 71, 79, 80, 82, 86, 87, FAA Orders 1050.17, and 1050.18, EO 12843: Procurement Requirements and Policies for Federal Agencies for Ozone-Depleting Substances, EO 12856: Federal Compliance with Right-to-Know Laws and Pollution Prevention Requirements, FAR implementing regulations, 48 CFR Part 23, Clean Air Act Amendments 1990. <i>If yes:</i> 2. Prepare and submit CAA Construction and Operating Permit if required. 3. Unless specified in a permit exemption rule promulgated by the cognizant state air pollution control agency or local district, installation or modification of the facilities may require permits. Permit triggers vary widely from state to state and may encompass one or more of the following: maximum rated capacity hours of operation, location of source in non-attainment areas, and maximum potential to emit. 4. Investigate federal, state and local permit requirements for facility. |
| ASBESTOS | Will activity potentially impact presumed or known asbestos containing materials (ACM)? Identify if an Asbestos Survey was done, when, and where asbestos materials are located in the work area. Include Asbestos Work Permit requirements. Notes: | | X | | 1. Check Index of Asbestos and Lead Paint Surveys to see if the facility has been surveyed for asbestos. Index available from the FOPOC and ANS-500. 2. If no survey available, then all impacted suspect materials must be assumed ACM or sampled & tested. Although facilities constructed after 1988 most likely do not contain asbestos it is important to remember ACM materials are still being installed into new buildings. Cursory samples may be required – see EOSH Coordinator. 3. Review FAA Order 1050.20, SMO Asbestos Control Program (ACP), bargaining union agreements, CAA implementing regulations, 40 CFR Part 61, Subpart M Toxic Substances Control Act (TSCA) implementing regulations, 40 CFR Part 763, 29 CFR 1926.1101, 29 CFR 1910.1001, state, and local regulations. <i>If yes:</i> 4. Include in specifications applicable regulatory and union agreement requirements along with safe work practices. See ANS-500 for approved specifications and work plan procedures. |
| CHEMICALS FEDERAL INSECTICIDE FUNGICIDE AND RODENTICIDE ACT (FIFRA) | Does the project require the application of pesticides and/or herbicides? Notes: | | X | | 1. Review FAA Order 1050.17, FIFRA implementing regulations, 40 CFR Parts 152, 162, and 171 and State regulations. <i>If yes:</i> 2. Specify the use of State-certified applicators, where applicable. 3. Specify copy of application records be provided to FOPOC/Environmental Protection Specialist. |
| CHLOROFLUOROCARBONS (CFC) | Is CFC containing equipment being replaced, installed or disposed? (i.e. refrigeration systems, Halon systems, HVAC systems, etc.) Notes: | | X | | <i>If yes:</i> 1. Review FAA Order 1050.17 & 18 and 40 CFR 82. 2. Replace with non-CFC equipment. 3. Recover & recycle existing CFCs. |

| Issue | | Yes | N/A | No | Action Item and Notes |
|--|---|-----|-----|----|--|
| COMPRESSED GAS | Are compressed gasses utilized? Notes: | | X | | <i>If yes:</i> 1. Review 29 CFR 1910 Subpart M, 29 CFR 1910.101 and 29 CFR 1910.169. |
| ENERGY | Install new lighting, HVAC, or environmental controls? Notes: | | X | | 1. Review Energy Policy Act of 1992 and Executive Order 12902 & 12759, 12844: Federal Use of Alternative Fueled Vehicle, 12845: Requiring Agencies to Purchase Energy Efficient Computer Equipment that require energy reduction in all Federal buildings by 2005. Review FAA Order 1053.1A. <i>If yes:</i> 2. <i>Lighting:</i> Use energy efficient system with electronic ballast. 3. <i>HVAC:</i> Use energy efficient equipment. 4. <i>Controls:</i> Contact FOPOC, Energy Manager. 5. <i>Building/Structure:</i> Contact FOPOC, Energy Manager. |
| ENVIRONMENTAL DUE DILIGENCE AUDIT (EDDA) REFER TO SOP 30 | Acquire, lease and/or dispose of land property? Notes: | | X | | <i>If yes:</i> 1. Review FAA Order 1050.17 & 19, Community Environmental Response Facilitation Act (CERFA). 2. Coordinate with EOHS Specialist and FAA Real Estate. 3. If on airport property, obtain Hold Harmless Agreement. 4. Conduct EDDA if off airport property or Hold Harmless Agreement is not obtained. |
| FLUORESCENT LAMPS | Dispose, install or recycle fluorescent lamps? Notes: | | X | | <i>If yes:</i> 1. Comply with applicable regulatory requirements. Initiate recycling efforts if feasible. |
| FUEL STORAGE TANKS | Install, remove and/or replace an underground or aboveground storage tank or piping? If the project is new construction, is an existing UST and/or piping near the project site being impacted? Notes: | | X | | 1. Check Storage Tank Inventory available from the Regional FST Manager or the FOPOC or ANI Representative. 2. Review RCRA implementing regulations, 40 CFR Parts 261, 262, 265, 266, 268, 273, 279, 280-282, CERCLA implementing regulations, 40 CFR Parts 302, 370, CWA implementing regulations, 40 CFR Parts 112-117DOT implementing regulations, 49 CFR Parts 171-179 SARA implementing regulations, CFR Parts 355, 370 Executive Order 12856 Delete (Land Disposal Program Flexibility Act, 1966, LDPFA (PL 104-119)). 3. Non Hazardous Solid Waste implementing regulations, 40 CFR Parts 240-244 (recycling), 257-258. <i>If yes:</i> 4. Review FAA Order 1050.15A, 16, 17, 40 CFR 280, and State Regulations. 5. Use State-specific plans & specifications for removal and installation available from the Regional FST Manager, FOPOC or ANI Representative. 6. Where state and localities require use licensed UST/AST removers and installers. 7. Prepare Spill Prevention Control and Countermeasure Plans (SPCC) for new tank installations per 40 CFR 112. |
| HAZARDOUS AND SOLID WASTE MANAGEMENT | What types of waste will be generated as a result of the project? Notes: Microbiologically contaminated dry wall | X | | | 1. Determine if the waste generated is classified as a hazardous waste by determining if it is a listed hazardous waste or if it is characteristically hazardous. 2. Review FAA Order 1050.17 (Chapter 12), 40 CFR 260-266, 273, 279, and state hazardous waste regulations. <i>If yes:</i> 3. Estimate the amount of hazardous waste that will be generated to determine the type of generator (e.g., large quantity, small quantity, or conditionally exempt). 4. Obtain an EPA ID # or determine if the facility's ID # can be used for the project without changing their generator status. 5. Ensure that hazardous waste is stored in accordance with the appropriate generator requirements. 6. Ensure manifesting and recordkeeping/reporting requirements are followed. 7. Ensure that a permitted transporter transports the waste and that the waste is shipped to a permitted TSDF. |

| Issue | | Yes | N/A | No | Action Item and Notes |
|---|---|-----|-----|----|--|
| LEAD BASED PAINT & LEAD-ACID BATTERIES | Disturb, store, dispose or recycle of lead paint or lead acid batteries? Notes: | | X | | <ol style="list-style-type: none"> Review 29 CFR 1926.62, RCRA implementing regulations, 40 CFR Part 262, TSCA implementing regulations, 40 CFR Part 745, OSHA implementing regulations, 29 CFR 1926.62. Check index of Lead Paint Surveys to see if sampling has been conducted. If no paint sampling results available, then all impacted materials must be assumed lead containing or contaminated until sampled & tested. <p><i>If yes:</i></p> <ol style="list-style-type: none"> Comply with applicable OSHA regulatory requirements for worker protection and EPA requirements for removal & disposal. Initiate recycling efforts for scrap metal or batteries when feasible. |
| LOCKOUT/TAGOUT & HIGH VOLTAGE | Are electrical systems being impacted? Notes: | | X | | <ol style="list-style-type: none"> Review 29 CFR 1910.333, 1910.147 <p><i>If yes:</i></p> <ol style="list-style-type: none"> Comply with applicable regulatory requirements including 29 CFR 1910.147 and 29 CFR 1926.431. Initiate recycling efforts if feasible. Only utilize fully trained personal to perform electrical work and lockout/tagout procedures. |
| NATIONAL ENVIRONMENTAL POLICY ACT (NEPA) REFER TO SOP 30 | Does the project potentially impact the environment with respect to noise, water quality, air quality, wetlands, flora and fauna, wildlife, historic and archeological sites, endangered species & other protected areas? Notes: | | X | | <ol style="list-style-type: none"> Review NEPA implementing regulations, 40 CFR Parts 1500-1508, FAA Order 1050.10D, Endangered Species Act implementing regulations, 50 CFR Parts 402, 450-453. <p><i>If yes:</i></p> <ol style="list-style-type: none"> Is activity classified as a Categorical Exclusion (CATX)? If not a CATX, prepare Environmental Assessment (EA). Prepare Finding Of No Significant Impact (FONSI) or Environmental Impact Statement (EIS) as appropriate. |
| PCBs, MERCURY, RADIOACTIVE, RADON, ETC. | Relocate or dispose of PCBs and/or PCB containing equipment? (Fluorescent fixture ballast's, electric transformers and equipment) Dispose of Mercury Switches, Radioactive tubes, or other hazardous waste? Is there evidence or potential for elevated radon levels in construction site? Are CFCs or PCBs being recycled? Are capture systems employed? Notes: | | X | | <ol style="list-style-type: none"> Check the PCB inventory available from each FPOPC. Determine if the PCB component was manufactured before 1984. If so, dispose of as PCB material. Determine if radon will or is an influence at the site. <p><i>If yes:</i></p> <ol style="list-style-type: none"> Review FAA Order 1050.14A, 1050.17 and 3910.3A, 40 CFR 190-199, 42 CFR 2011-2259, TSCA implementing regulations 40 CFR 761 Subpart D, 40 CFR 260-270, 10 CFR 30, applicable IEEE standards and State regulations. NRC implementing regulations, 10 CFR Parts 16-71, TSCA Title III, Indoor Radon Abatement Act of 1988 |
| SAFETY | Safety issues? I.e. Clear aisle space, electrical equipment clearances, toe boards, hand rails, stair clearances, safety cages, confined spaces, fall protection, fire protection, fire life safety, personal protective equipment, hearing protection, ladders, Hazard Communication (HAZCOM), first aid, accident prevention, construction safety, etc. Notes: | X | | | <ol style="list-style-type: none"> Review FAA Orders 1050.17 & 3900.19A, and 29 CFR 1910 & 1926. <p><i>If yes:</i></p> <ol style="list-style-type: none"> Comply with applicable regulatory requirements. Comply with 5000-pound shock load for anchorage per person. Insure safety boards are furnished with the necessary signs and PPE as required for the particular hazard |

| Issue | | Yes | N/A | No | Action Item and Notes |
|---|---|----------|----------|----|---|
| TRAINING | Are personnel required to have training to be qualified to work? Notes: | X | | | <i>If yes:</i> 1. Comply with applicable regulatory requirements. 2. Maintain training records on-site and confirm records are valid for duration of project. 3. Provide training for all facility occupants as required by law. |
| WATER CLEAN WATER ACT (CWA) & SAFE DRINKING WATER ACT (SDWA) | Does the project involve the clearing, grading, and excavation of over 5 acres; (1 acre is proposed rule and is not final) impact navigable waters; utilize equipment which can discharge to storm water or wastewater systems (cooling tower discharges or boiler blow downs)? State and local regulatory authorities may impose more stringent SWDP requirements. Notes: | | X | | 1. Review FAA Order 1050.17, Safe Drinking Water Act (SDWA) implementing regulations, 40 CFR Parts 141, 143, SDWA implementing regulations, 40 CFR Parts 144-149, Executive Order 12902, 40 CFR 120-143, and State regulations. 2. Review pollution prevention under EO 12856, EO 12873: Federal Acquisition, Recycling, and Waste Prevention. 3. Clean Water Act implementing regulations, 40 CFR Parts 110, 112, 122, 136, 400-460, and 33 CFR Part 154, FAA Order 1050.15A <i>If yes:</i> 4. Coordinate permit with EOHS personnel and agencies (i.e. NPDES, sanitary sewer discharge, etc.) as required. 5. Unless specified in a permit exemption rule promulgated by the cognizant state air pollution control agency or local district, installation or modification of the facilities may require permits. Permit triggers vary widely from state to state and may encompass one or more of the following: maximum rated capacity hours of operation, location of source in non-attainment areas, and maximum potential to emit. 6. Prepare Spill Plan (SPCC) for fuel tanks as required by 40 CFR 112. |

GREAT LAKES REGION EHS CONTACTS

AGL REGION

| | | PHONE | FAX |
|--------------------------|------------------------|--------------|--------------|
| 471 Supervisor | Maureen Clark | 847/294-8557 | 847/294-8436 |
| 471 ROSHM | Wayne Vogelsburg | 847/294-8453 | 847/294-8436 |
| 473 Energy | Stanley Lee | 847/294-8457 | 847/294-8436 |
| 471 Safety | Bill Jaeger (NISC) | 847/294-7613 | 847/294-8436 |
| 471 Safety | Lenore McDonald (NISC) | 847/294-7666 | 847/294-8436 |
| 471 F/L Safety | Bill Ibbotson | 847/294-8559 | 847/294-8436 |
| 471 Environmental | Jose De Leon | 847/294-8409 | 847/294-8436 |

ANI Chicago Implementation Center

| | | | |
|----------------------------|--------------------|--------------|--------------|
| 430 Safety/Environ. | Homer Benavides | 847/294-8078 | 847/294-7841 |
| 430 Environmental | Steve Myers (NISC) | 847/294-8419 | 847/294-8077 |
| PASS Safety Rep. | Glen Fidge | 616/837-6706 | 616/837-8285 |

AGL Air Traffic Division

| | | | |
|--------------------------|---------------|--------------|--------------|
| 510 | Norm Leader | 847/294-7559 | 847/294-8101 |
| NATCA Safety Rep. | Taylor Koonce | 317/484-6600 | |

SUPERIOR SMO

| | | | |
|-----------------------|--------------------|----------------|--------------|
| EPS | Bill Bader | 440/774-0816 | 440/774-0835 |
| Safety Manager | VACANT | | |
| WI Hazmat | Mike Diaz | (847) 608-5827 | 847-608-5772 |
| MI Hazmat | Musa Abuzir (NISC) | 734/487-7323 | 734/487-7427 |
| Safety | Musa Abuzir (NISC) | 734/487-7323 | 734/487-7427 |
| Energy | Steve North | 920/490-8617 | 920/431-5880 |

FAA AGL CONSTRUCTION and MAINTENANCE PROJECT VENTILATION and AIRBORNE CONTAMINANTS CHECKLIST

Purpose

This checklist is intended to be used as a tool by those who design, review and/or oversee construction and maintenance activities that potentially have ventilation related airborne contaminant impacts on AT/AF operations. This tool should be used, as appropriate, during design and review phases of construction and maintenance activities. Emphasis should be placed on using this checklist as a tool to assess as well as reassess hazards as the project progresses. This checklist is intended to:

- Promote sensitivity to potential ventilation related airborne contaminants associated with projects
- Stress the importance of not disrupting NAS operations
- Assist in identifying and validating potential project hazards
- Assist in preventing ventilation related airborne contaminant incidents/accidents and facility shutdowns
- Ensure appropriate contractor measures and controls are in place to address potential project hazards
- Facilitate discussion with the contractor regarding plans to prevent/minimize potential incidents/accidents
- Enhance coordination between Occupational, Safety, Health /Environmental (OSH/E) professionals, project personnel and contractors
- Raise OSH/E awareness to potential airborne contaminant hazards associated with construction and maintenance projects

- This checklist relies on the training and professional judgment of the user. OSH/E personnel should be consulted, as needed.
- A facility point of contact (POC) with an understanding of facility procedures and equipment considerations should participate in site evaluation.

1 Project Summary Information

Fill in the requested site-specific information.

| | | | |
|-------------------------------|--------------------------------------|----------------|----------------|
| Project Name and Description: | DTW ATCT Microbiological Remediation | | |
| SMO: | DET District _____ | Facility ID: | DTW ATCT _____ |
| Project Designer: | B. Hebert, D. Morse _____ | Transmittal #: | _____ |
| Env & Safety Review By: | _____ | Date: | 07/18/08 |
| Project/Activity/Task: | _____ | | |
| Planned Start: | _____ | | |
| Expected Completion Date: | _____ | | |
| Contractor Contact: | Name: _____ | Phone: | _____ |
| OSH/E Contact: | Name: _____ | Phone: | _____ |
| Facility POC: | Name: Steve McClinchey | Phone: | 734-995-8502 |

Facility Procedures

What site-specific procedures and considerations associated with airborne contaminants may apply to this project? For example, will asbestos contingency plans be used/required? If a specific plan is required, is it available? Has the plan been reviewed to ensure accuracy and applicability to the project? If a plan is required and "No" is circled for available and/or reviewed, use the closeout date box to indicate when appropriate measures or controls have been addressed.

| Facility Procedures | If No, Indicate Close-out Date | | | | | |
|--|--------------------------------|-----------|---|----------|---|---|
| | Required | Available | | Reviewed | | |
| Asbestos Contingency Plan | N | Y | N | Y | N | |
| Work Permits (e.g. Asbestos, Lead) | N | Y | N | Y | N | |
| Emergency Plans (e.g. Occupant Emergency Plan) | Y | Y | N | Y | N | |
| Hazard Communications (e.g. MSDSs) | Y | Y | N | Y | N | |
| Other: | Y | N | Y | N | Y | N |

3 Project Airborne Contaminants

Think about the project and its potential hazards. Consider sensitive NAS operations and all facility personnel that may be impacted by the projects. As an example: Construction activities with potential for impacting asbestos materials in or near sensitive operations could result in incidents that disrupt NAS operations. For each potential project hazard, indicate (with a checkmark) a potential for exposure/release/incident.

| Potential Airborne Contaminate Project Hazards | | | | | |
|--|-------------------------------------|---------------------------------------|-------------------------------------|--|-------------------------------------|
| | <input checked="" type="checkbox"/> | | <input checked="" type="checkbox"/> | | <input checked="" type="checkbox"/> |
| Asbestos (e.g. Tiles & Insulation) | <input type="checkbox"/> | Airborne dust (not lead or asbestos) | <input checked="" type="checkbox"/> | Lead paint | <input type="checkbox"/> |
| Installation of carpet/vinyl flooring | <input type="checkbox"/> | Wall coverings (paneling, wall paper) | <input checked="" type="checkbox"/> | Paints/varnishes | <input type="checkbox"/> |
| New furniture/cubicles/cabinets | <input type="checkbox"/> | Use of sealants/caulks | <input checked="" type="checkbox"/> | Solvents | <input type="checkbox"/> |
| Cleaners/detergents | <input checked="" type="checkbox"/> | Other chemicals | <input type="checkbox"/> | Combustion products (CO, hydrocarbons) | <input type="checkbox"/> |
| Pesticides | <input type="checkbox"/> | Molds/mildew/fungus | <input checked="" type="checkbox"/> | Animal feces (rodents, birds) | <input type="checkbox"/> |
| Roofing products | <input type="checkbox"/> | Confined spaces | <input type="checkbox"/> | Grinding/sanding | <input type="checkbox"/> |
| Welding/cutting indoors | <input type="checkbox"/> | Welding/cutting outdoors | <input type="checkbox"/> | Construction/demolition | <input checked="" type="checkbox"/> |
| Other: | <input type="checkbox"/> | Other: | <input type="checkbox"/> | Other: | <input type="checkbox"/> |

4 Site Ventilation

After reviewing the potential airborne contaminants in block 3, ensure that measures and controls to address applicable site airborne contaminants and ventilation issues are addressed. In your judgment, have appropriate measures been addressed to minimize the potential project airborne contaminants (see block 3)? If yes, check the appropriate boxes below. If a potential project airborne contaminants hazard has been identified in block 3 and no associated measures or controls are evident, then check the appropriate NO boxes below. If a NO box is checked, use the closeout date box to indicate when appropriate measures or controls have been addressed.

| Program Elements | Yes | N/A | No * | If No, Indicate Close-out Date | Notes |
|---|-----|-----|------|--------------------------------|---|
| Chemical Substances (all projects) | | | | | |
| 1. MSDS(s) have been reviewed | | | | | |
| 2. Substitute products have been evaluated | | | | | |
| 3. MSDS(s) are available on-site for all substances | | | | | |
| 4. Building occupants have been notified of potential odors/hazards | | | | | |
| 5. Substances will cure without a "bake-out" period. | | | | | |
| (a). If no was answered to the above question (5), have building occupants been notified? | | | | | |
| 6. Will odors have dissipated prior to shift change | | | | | |
| (a). If no was answered to the above question (6), has following shift been notified? | | | | | |
| 7. Substance is without strong odors/vapors that may migrate into or near occupied areas. | | | | | (If yes, skip to question 8) |
| (a). If no was answered to above question (7), can work be done when building is unoccupied? | | | | | (If yes, skip to question 8) |
| (a)(i) If no was answered to above question [(7)(a)], can area be pressurized? | | | | | (If yes, section on supplemental ventilation must be completed) |
| (a)(ii) If no was answered to above question [(a)(i)], the existing AHU is adequate for ventilation as configured? | | | | | (If no, section on supplemental ventilation must be completed) |
| For Outdoor Projects (roofing, vegetation control) | | | | | |
| 8. AHU intake vents have been sealed | | | | | |
| 9. All other means by which vapors may enter the facility (open windows, window AC units, etc.) have been eliminated. | | | | | |
| For Indoor Projects (painting, remodeling) | | | | | |
| 10. Existing AHU is adequate for ventilation | | | | | (If no, supplemental ventilation section must be completed) |
| 11. Means of egress from occupied areas will remain clear and unaffected during the project. | | | | | |
| Supplemental Ventilation | | | | | |
| 12. Existing AHU is adequate for ventilation needs associated with this project as configured. | | | | | (If yes, skip to question 18) |
| 13. System can be reconfigured to meet ventilation requirements | | | | | |
| (a) If yes was answered to question (13), are personnel trained to reconfigure system available | | | | | |
| 14. Ventilation requirements can be met without supplemental ventilation units. | | | | | |
| (a). If no, are units available on site? | | | | | |
| 15. Does facility have adequate power supply and outlets for supplemental ventilation units | | | | | |
| 16. Duct route has been evaluated | | | | | |
| 17. Exhaust from units is prevented from being reintroduced to facility | | | | | |
| 18. Is adequate return air available for ventilation units? | | | | | |
| Air Monitoring | | | | | |
| 19. The project may proceed without air monitoring. | | | | | |
| (a). If no was answered to above question (16), has air monitoring company been contracted | | | | | |
| 20. Have arrangements been made for air monitoring in case of accidental substance release. | | | | | |
| Other: | | | | | |
| | | | | | |
| | | | | | |
| | | | | | |

5 Review Information

| Reviewed By: | Name | Signature | Date |
|-------------------|------|-----------|------|
| OSHA&E Contact: | | | |
| Facility Manager: | | | |
| Facility POC: | | | |
| Other: | | | |

6 AGL OSH / E CONTACTS

| AGL REGION | | PHONE | FAX |
|----------------------|------------------------|--------------|--------------|
| 471 ROSHM | Wayne Vogelsburg | 847/294-8453 | 847/294-8436 |
| 471 RPMES | Joe Nakanishi | 847/294-8461 | 847/294-8436 |
| 471 Energy | Stanley Lee | 847/294-8457 | 847/294-8436 |
| 471 FLS | Bill Ibbotson (NISC) | 847/294-8559 | 847/294-8436 |
| 471 Project Mgmt | Alisa Liu (NISC) | 847/294-7666 | 847/294-8436 |
| 471 Env & Safety | Christine Warta (NISC) | 847/294-8147 | 847/294-8436 |
| 471 Env & Safety | Bill Jaeger | 847/294-7613 | 847/294-8436 |
| ANI Great Lakes IC | | | |
| 420 Env & Safety | Denise Trausch (NISC) | 847-294-8415 | 847/294-8172 |
| CHICAGO SMO | | | |
| SECM & Safety Mgr | Dave Weber | 847/608-5814 | 847/608-5872 |
| CHI Hazmat | Mike Diaz (JALCO) | 847/608-5827 | 847/608-5872 |
| CHI Energy | William Hui | 733/601-7717 | |
| ZAU Hazmat | Shawn Adams | 847/608-5725 | 847/608-5872 |
| CROSSROADS SMO | | | |
| SECM | Ann Sheehan | 317/246-4518 | 317/246-4590 |
| SECM | Bill Watson | 317/246-4517 | 317/246-4590 |
| IND Hazmat | Jim Euler (JALCO) | 317/246-4519 | 317/246-4590 |
| ZID Hazmat | Kelly Yochum (NISC) | 317/247-2618 | 317/247-2619 |
| Energy | Ashfaq Hussain | 317/247-2291 | 317/247-2246 |
| DAKOTA-MINNESOTA SMO | | | |
| SECM | Alex Gintner | 651/463-5921 | 612/463-5692 |
| DMS Hazmat | Ted Frey (NISC) | 651/463-5920 | 612/463-5692 |
| DMS Hazmat | Scott Scheer (NISC) | 651/463-5922 | 612/463-5692 |
| ENERGY | Steve Aldridge | 651/463-5649 | |
| SUPERIOR SMO | | | |
| SECM | Bill Bader | 440/774-0815 | 440/774-0835 |
| Safety Manager | | | |
| WIS Hazmat | | | |
| MCH Hazmat | Musa Abuzir (NISC) | 734/487-7323 | 313/487-7427 |
| Energy | Steve North | 920/490-8617 | 920/431-5880 |
| OHIO SMO | | | |
| SECM & Safety Mgr | Bill Bader | 440/716-7136 | 440/716-7105 |
| OHIO Hazmat | John Guty (NISC) | 440/716-7139 | 440/716-7105 |
| ZOB Hazmat | Kitty Woldow (NISC) | 440/716-7138 | 440/716-7105 |
| Energy | Dale Harbert | 440/716-7181 | 440/716-7105 |

Consult with your SECM or designated OSH/E professional for additional guidance and assistance.

PROCUREMENT REQUEST DATA

| | | | |
|-----------------------|---|--|---|
| Street Address: | FEDERAL AVIATION ADMINISTRATION DTW SSC. DETROIT METRO AIRPORT BUILDING 801, ROOM 117 DETROIT, MI 48242 | | |
| City | DETROIT | | |
| State | MI | | |
| Zip code | 48242 | | |
| Requisitioning Office | Detroit District | | |
| Supplies or Services | DETROIT, MI (DTW) AIR TRAFFIC CONTROL TOWER (ATCT) MICROBIOLOGICAL REMEDIATION | | |
| Term | THE PROJECT DURATION IS 30-DAYS OF WORK | | |
| Estimated Cost | \$107,400.00 | | |
| Vendor | MIS ENVIRONMENTAL 304 S. NIAGRA ST SAGINAW, MI 48602 (517) 793-3990 X 212 | UDECON 678 FRONT ST., SUITE 160 GRAND RAPIDS, MI 49504 877-833-2668 | ENECOTECH 39155 COUNTRY CLUB DR., SUITE B40 FARMINGTON HILLS, MI 48331 248-489-0809 |
| | ENVIRONMENTAL PROFESSIONALS, INC. 25950 LABANA WOODS DR. TAYLOR, MI 48180 313-291-2214 | ENVIRONMENTAL RESOURCES MANAGEMENT 3352 128 TH AVE. HOLLAND, MI 49424 | INNOVATIVE ENVIRONMENTAL 9948 E. GRAND RIVER BRIGHTON, MI 48116 810-714-4959 |
| Scope of Work | <p align="center">MICROBIOLOGICAL REMEDIATION PROJECT AT DETROIT METROPOLITAN AIRPORT AIR TRAFFIC CONTROL TOWER</p> <p>The contractor shall provide all the services, equipment, supplies, materials, and labor required. Work shall include, but not limited to, the following: ALL FLOORS:</p> <ol style="list-style-type: none"> Prior to performing microbiological remediation procedures, the contractor shall seal all critical penetrations and openings to the work area with a minimum of two layers of 6-mil polyethylene, and shall be responsible for ensuring adjoining areas are not exposed to the microbiological contamination during the remediation. Remove any MCM between the bottom metal runner/track and the concrete floor; between the top metal runner/track and the structural deck; and between the metal stud and exterior concrete wall. The contractor shall minimize dust generation and use the methodologies outlined in <i>Guidelines on Assessment and Remediation of Fungi in Indoor Environments</i> (GARFIE) (See Specification Attachment 1) for dust prevention and suppression. All removals and other cleaning procedures shall be conducted at night between the hours of 11:00 pm and 6:00 am. Negative air pressure equipment shall be equipped with a HEPA filter and discharged outside of the building whenever possible, otherwise discharged through a second HEPA filter in order to permit recirculation of air inside the building. Once the mold has been removed and clearance has been achieved, and the stained surfaces have been cleaned, then remove all partition walls, doors and door frames, except those around the elevator core and stairwell. Cut a 1/2" gap between the bottom of the gypsum board and the concrete deck. Fill the gap with a 2-hr fire-rated caulk in the remaining partition walls around the elevator core and stairwell corridor. Paint elevator core exterior and stairwell corridor with mold resistant paint. | | |

D. Morse
08/08/08

8. Furnish and install fire-rated access panels in the center of the north and east elevator core wall. The bottom of the panel shall be 24" above the floor. Do not penetrate the shaft liner. See detail "B" on drawing DTW -D-ATCT-A11.

FLOOR 3

ROOM 327

1. The contractor shall provide additional cleaning procedures and pipe insulation removal/replacement.
2. Approximately 15 linear feet of 18", water stained and/or contaminated chilled and heating water pipe insulation shall be removed and replaced.

ROOM 328

1. A mini containment shall be established consisting of a single layer of 6-mil polyethylene sheeting. A negative pressure enclosure system shall be established as described in section 1B.9 Remediation Area.
2. The east (elevator shaft) wall, up to a height of 2', and the south (elevator shaft) wall, up to a height of 2', shall be HEPA vacuumed and then wet wiped with an approved cleaning solution.

FLOOR 4

ROOM 427

1. The contractor shall provide additional cleaning procedures and pipe insulation removal/replacement.
2. Approximately 4 linear feet of 11" and 6 linear feet of 18" water stained and/or contaminated chilled and heating water pipe insulation shall be removed and replaced.

ROOM 428

1. A containment and negative pressure enclosure system shall be established as described in section 1B.9 Remediation Area. A decontamination unit shall be established as described in section 1B.10 Decontamination Area.
2. Cleanup and removal of moisture and microbiological contaminated gypsum board, shaft liner, and insulation in the DTW ATCT room 428 in accordance with the guidelines established by the New York City Department of Health entitled *Guidelines on Assessment and Remediation of Fungi in Indoor Environments* (GARFIE) (See Specification Attachment 1).
3. Remove and replace gypsum board, shaft liner, and insulation totaling approximately 243 square feet:
 - a. The east (elevator shaft) wall, 8' wide to a height of 5' (surface layer), 8' wide to a height of 4'6" (concealed layer), and 8' wide to a height of 4' (shaft liner).
 - b. The south (elevator shaft) wall, 10' wide to a height of 5' (surface layer), 10' wide to a height of 4'6" (concealed layer), and 10' wide to a height of 4' (shaft liner).
 - c. **Elevator Shaft liner removal and replacement requires coordination with the Elevator Maintenance company and Air Traffic to schedule limited elevator shutdown time.**

FLOOR 5

ROOM 527

1. A mini containment shall be established consisting of a single layer of 6-mil polyethylene sheeting but a negative pressure enclosure system is not required. Mist any contaminated areas prior to removal. Upon

completion, the work area shall be HEPA vacuumed and then wet wiped with a detergent solution.

2. Cleanup and removal of moisture and microbiological contaminated gypsum board, shaft liner, and insulation in accordance with the guidelines established by the New York City Department of Health entitled *Guidelines On Assessment And Remediation Of Fungi In Indoor Environments* (GARFIE) (See Specification Attachment 1).
3. Approximately 4 linear feet of 11" and 25 linear feet of 18" water stained and/or contaminated chilled and heating water pipe insulation shall be removed and replaced.
4. Remove and replace gypsum board and insulation totaling approximately 15 square feet, on the north wall, between the east wall and door to Room 527A, 2' wide to a height of 4' (surface layer) and 2' wide to a height of 3'6" (concealed layer).

ROOM 527A

1. A mini containment shall be established consisting of a single layer of 6-mil polyethylene sheeting but a negative pressure enclosure system is not required. Mist any contaminated areas prior to removal. Upon completion, the work area shall be HEPA vacuumed and then wet wiped with a detergent solution.
2. Cleanup and removal of moisture and microbiological contaminated gypsum board, shaft liner, and insulation in accordance with the guidelines established by the New York City Department of Health Entitled *Guidelines on Assessment and Remediation of Fungi in Indoor Environments* (GARFIE) (See Specification Attachment 1).
3. Remove and replace gypsum board and insulation totaling approximately 5 square feet on the south wall, between the east wall and the door to Room 527, 2' wide to a height of 18" (surface layer) and 2' wide to a height of 12" (concealed layer).

ROOM 529

1. A mini containment shall be established consisting of a single layer of 6-mil polyethylene sheeting. A negative pressure enclosure system shall be established as described in section 1B.9 Remediation Area.
2. The portion of the east wall, between the south wall and stairwell doorframe, 2" wide to a height of 8', shall be HEPA vacuumed and then wet wiped with an approved cleaning solution.

FLOOR 6

ROOM 627

1. The contractor shall provide additional cleaning procedures and pipe insulation removal/replacement.
2. Approximately 20 linear feet of 11" and 25 linear feet of 18" water stained and/or contaminated chilled and heating water pipe insulation shall be removed and replaced.

ROOM 628

1. A mini containment shall be established consisting of a single layer of 6-mil polyethylene sheeting. A negative pressure enclosure system shall be established as described in section 1B.9 Remediation Area.
2. The east (elevator shaft) wall, up to a height of 4', shall be HEPA vacuumed and then wet wiped with an approved cleaning solution.
3. The south (elevator shaft) wall, up to a height of 4', shall be HEPA vacuumed and then wet wiped with an approved cleaning solution.

FLOOR 7

ROOM 727

1. The contractor shall provide additional cleaning procedures and pipe insulation removal/replacement.
2. Approximately 3 linear feet of 18" water stained and/or contaminated chilled and heating water pipe insulation shall be removed and replaced.

ROOM 727A

1. A mini containment shall be established consisting of a single layer of 6-mil polyethylene sheeting. A negative pressure enclosure system shall be established as described in section 1B.9 Remediation Area.
2. The portion of the west wall between the cable tray and the north wall, up to a height of 4', shall be HEPA vacuumed and then wet wiped with an approved cleaning solution.
3. The south wall above the door to room 727, 3' wide to a height of 3', shall be HEPA vacuumed and then wet wiped with an approved cleaning solution.

ROOM 728

1. A mini containment shall be established consisting of a single layer of 6-mil polyethylene sheeting. A negative pressure enclosure system shall be established as described in section 1B.9 Remediation Area.
2. The east (elevator shaft) wall, up to a height of 4', shall be HEPA vacuumed and then wet wiped with an approved cleaning solution.
3. The south (elevator shaft) wall, up to a height of 4', shall be HEPA vacuumed and then wet wiped with an approved cleaning solution.

FLOOR 8

ROOM 827

1. The contractor shall provide additional cleaning procedures and pipe insulation removal/replacement.
2. Approximately 4 linear feet of 11" water stained and/or contaminated chilled and heating water pipe insulation shall be removed and replaced.

ROOM 829

1. A mini containment shall be established consisting of a single layer of 6-mil polyethylene sheeting. A negative pressure enclosure system shall be established as described in section 1B.9 Remediation Area.
2. The portion of the east wall, between the south wall and stairwell doorframe, 2' wide to a height of 8', shall be HEPA vacuumed and then wet wiped with an approved cleaning solution.
3. The adjacent south wall, from the southeast corner westward, 1' wide to a height of 8', shall be HEPA vacuumed and then wet wiped with an approved cleaning solution.

FLOOR 9

ROOM 927

1. The contractor shall provide additional cleaning procedures and pipe insulation removal/replacement.
2. Approximately 4 linear feet of 11" water stained and/or contaminated chilled and heating water pipe insulation shall be removed and replaced.

ROOM 928

1. A containment and negative pressure enclosure system shall be established as described in section 1B.9 Remediation Area. A decontamination unit shall be established as described in section 1B.10

Decontamination Area.

2. Cleanup and removal of moisture and microbiological contaminated gypsum board, shaft liner, and insulation in the DTW ATCT rooms 928, in accordance with the guidelines established by the New York City Department of Health Entitled *Guidelines on Assessment and Remediation of Fungi in Indoor Environments* (GARFIE) attached and incorporated herein by reference (see attachment 1).
3. Remove and replace gypsum board, shaft liner, and insulation totaling approximately 311 square feet:
 - a. The east (elevator shaft) wall, 8' wide to a height of 5' (surface layer), 8' wide to a height of 4'6" (concealed layer), and 8' wide to a height of 4' (shaft liner).
 - b. The south (elevator shaft) wall, 10' wide to a height of 5' (surface layer), 10' wide to a height of 4'6" (concealed layer), and 10' wide to a height of 4' (shaft liner).
 - c. The northwest column beam enclosure, on the north wall, 6' wide to a height of 3' (surface layer), 6' wide to a height of 2'6" (concealed layer), and 6' wide to a height of 2' (shaft liner);
 - d. The west wall, 3' wide to a height of 3' (surface layer), 3' wide to a height of 2'6" (concealed layer), and 3' wide to a height of 2' (shaft liner).
 - e. **Elevator Shaft liner removal and replacement requires coordination with the Elevator Maintenance company and Air Traffic to schedule limited elevator shutdown time.**

FLOOR 10

ROOM 1028

1. A containment and negative pressure enclosure system shall be established as described in section 1B.9 Remediation Area. A decontamination unit shall be established as described in section 1B.10 Decontamination Area.
2. Cleanup and removal of moisture and microbiological contaminated gypsum board, shaft liner, and insulation in the DTW ATCT room 1028, in accordance with the guidelines established by the New York City Department of Health Entitled *Guidelines on Assessment and Remediation of Fungi in Indoor Environments* (GARFIE) attached and incorporated herein by reference (see attachment 1).
3. The north wall shaft liner in its entirety shall be HEPA vacuumed and then wet wiped with an approved cleaning solution.
4. Remove and dispose of existing carpet.
5. Remove and replace gypsum board, shaft liner, and insulation totaling approximately 792 square feet:
 - a. The north (elevator shaft) wall, 22' wide for the full height (surface layer, concealed layer and shaft liner).

CAPITALIZATION AUTHORIZATION

Date: 07/18/08

RAPM:

| | | | | | | | | |
|--|--|---|----------------------|---|-------|------------------|--|--|
| Job Order Number | | | | | | Commission Date: | | |
| Project Title | DTW ATCT Microbiological Remediation | | | | | | | |
| Facility Location and Location ID | FAC | FACTYP | RWY # | LOC ID | CCC | | | |
| | ATCT | ATCT | | DTW | C81NB | | | |
| City and State | Detroit, Michigan | | | | | | | |
| Project Remarks Moisture Damage Remediation | | | | | | | | |
| Note: | | | | | | | | |
| Closeout Type | <input checked="" type="checkbox"/> Full Close-out | <input checked="" type="checkbox"/> Plant (Real Property) | Verified PMC | <input type="checkbox"/> Attached | | | | |
| | <input type="checkbox"/> Partial Close-out | <input type="checkbox"/> Electronic | | <input type="checkbox"/> Sent to Logistics from SMO | | | | |
| PSR Complete: | | Reimbursable? | On Airport Property? | | | | | |

REAL PROPERTY INVENTORY

Fill in the asset descriptions, enter the "Percent of Asset" for each asset, then insert the "Percent of Total" subtotal for each asset type. Logistics and/or Accounting will apply values to each item on the RPI.

| Asset Type | Asset Description | Percent of Asset | Percent of Total |
|---------------------------|-------------------|------------------|------------------|
| Land | NA | | |
| | | | |
| | | | |
| | | | |
| | Total | | |
| Buildings | | | |
| | | | |
| | | | |
| | | | |
| | Total | | |
| Other Structures | Drywall = \$1,000 | | |
| | | | |
| | | | |
| | | | |
| | Total | | |
| GRAND TOTAL | | | |
| Constr./Installation Name | Signature | Routing Symbol | Telephone Number |
| RAPM Signature | | | |



APPLICATION FOR CONSTRUCTION OR ALTERATION
Wayne County Airport Authority
For Detroit Metropolitan Wayne County and Willow Run Airports
(Airport Tenants only)

For Airport Use Only

Project Review No.

C/A Permit No.

INSTRUCTIONS: Use this form to apply for a Wayne County Airport Authority Construction/Alteration Permit to construct, enlarge, renovate, alter or remove any site or facility within the limits of Detroit Metropolitan Wayne County Airport or Willow Run Airport. This application must be accompanied with ten (10) sets of design reports, plans and specifications that describe the proposed work. Send completed application with original signature and accompanying documentation to: Wayne County Airport Authority; Planning and Capital Improvement Office; Detroit Metropolitan Wayne County Airport; L.C. Smith Terminal - Mezzanine; Detroit, Michigan 48242. Application must be typed or printed using ink.

1. Applicant Information (Tenant)

a. Official Name of Applicant (*Airport Tenants only*)

Federal Aviation Administration

b. Mailing Address (*Number, Street, City & Zip*)

FAA Cleveland ARTCC
 326 E. Lorain St., Room 113
 Oberlin, OH 44074

c. Applicant's Contact Person (*Authorized employee/agent*)

David P. Machala

d. Phone

(440) 774-0826

e. Fax

(440) 774-0835

f. E-mail Address

david.p.machala@faa.gov

2. Contractor Information

a. Prime Contractor (*or other to perform work*)

b. Mailing Address (*Number, Street, City & Zip*)

c. Contact Person

d. Phone

()

e. Fax

()

f. E-mail Address

3. Proposed Project Information

a. Name of Building/Site to be Altered

b. Airport Building Number

c. Airport (*Check one*)

DTW YIP

d. Area/Space of Building/Site affected by Proposed Project

e. Purpose of Construction or Alteration

f. Description of Work to be Performed (*use additional sheet if necessary*)

Check Box if Additional Sheet is Attached

See Attached Scope of Work

g. Estimated Design/Engineering Cost (*US Dollars*)

\$ In House Government Estimate

h. Estimated Construction Cost (*US Dollars*)

\$110,000

i. Submitted with this Construction or Alteration Application are the following:

FAA Form 7460-1 Insurance Certificate Performance Bond Labor and Material Bonds

4. Applicant Authorization

All work shall be done at no expense to the Wayne County Airport Authority or the County of Wayne, and the applicant agrees to reimburse said Authority and County for damage to property of the Authority and the County. Applicant assumes any and all liabilities and further agrees to (1) Save harmless and indemnify the Airport Authority and the County; (2) Comply with all conditions under which a Construction or Alteration Permit is granted; (3) Pay the Authority any required review, inspection and permit fees within ten days of billing therefore; (4) Notify the Authority's Planning and Capital Improvement Office of the date the above work is to be commenced and the date the work is to be completed.

a. Applicant's Signature (*Airport Tenants only*)

b. Date

c. Applicant's Name

David P. Machala

d. Title

NPPM

L.M. Scope

NISC SOW For

~~4905~~
~~3~~
~~1/2 way~~
~~T.R. King~~

→ **Detroit Air Traffic Control Tower (ATCT) Mold Inspection**

1. Background

The ATCT is the Detroit Metropolitan Airport in Romulus, Michigan. A visual inspection for the presence of mold is needed that would include the entire ATCT and base building. The purpose of the visual inspection is to identify any areas of visible mold. The Certified Industrial Hygienist (CIH) will be escorted by facility and Central Service Area (CSA) staff. The CIH will gather photographic evidence as needed to document the relevant conditions at the facility. The CIH will prepare a report detailing the findings. No sampling will be conducted as part of this effort.

2. Scope

The contractor must be a Certified Industrial Hygienist (Comprehensive Practice by the American Board of Industrial Hygiene) and have at least 5 years experience in Indoor Air Quality (IAQ) investigations, particularly mold. In the interest of meeting the requirement for an independent third party consultant, we prefer a CIH from outside the Detroit area, as this site has received considerable media attention in that area. We request a CIH who has knowledge and experience in conducting IAQ investigations at FAA facilities but no prior activity at this particular ATCT. The work must be conducted within the next two weeks. We expect up to 40 hours labor, travel expenses, and documentation expenses to comprise the overall effort.

3. Period of Performance

The period of performance for this SOW shall be from award through 2 weeks after the award date.

4. Personnel

The Contractor shall provide the following expertise in support of this SOW:

Certified Industrial Hygienist (Comprehensive Practice by the American Board of Industrial Hygiene) and have at least 5 years experience in Indoor Air Quality (IAQ) investigations, particularly mold.

5. Schedule of Deliverables

The work must be conducted during the 2 weeks following the award.

6. Deliverables

- Gather photographic evidence as needed to document the relevant conditions at the facility.
- Prepare a report detailing the findings.
- No sampling will be conducted as part of this effort.

7. Travel

In the interest of meeting the requirement for an independent third party consultant, we prefer a CIH from **outside** the Detroit area, as this site has received considerable media attention in that area. The CIH will need to have knowledge and experience in conducting IAQ investigations at FAA facilities but no prior activity at this particular ATCT.

8. Other Direct Costs

Other Direct Costs (ODCs), to include travel, and documentation expenses shall be presented for consideration prior to any purchases being performed. ODCs shall be presented for payment at cost and without additional fee. The Contractor shall provide reasonable validation that reasonableness was exercised in the purchase of documentation expenses or travel for support of this SOW

9



FOH

Federal Occupational Health
a component of the US Public Health Service



INDOOR AIR QUALITY/FUNGAL VISUAL ASSESSMENT AND CONSULTATION

Conducted

For the

FEDERAL AVIATION ADMINISTRATION
REGIONAL OCCUPATIONAL SAFETY AND HEALTH
OPERATIONS BRANCH, AGL 471C
GREAT LAKE REGIONAL OFFICE
2300 DEVON AVENUE
DES PLAINS, IL 60018

At the

FEDERAL AVIATION ADMINISTRATION
Detroit Metropolitan Wayne County Airport (DTW)
Air Traffic Control Tower (ATCT)
Building 801
Romulus, MI 48242

May 5, 2006

Conducted by

U.S. PUBLIC HEALTH SERVICE
FEDERAL OCCUPATIONAL HEALTH SERVICES
1301 Young Street, Suite 772
Dallas, Texas 75202



FOH



Indoor Air Quality/Fungal Consultation Federal Aviation Administration

FEDERAL AVIATION ADMINISTRATION
Detroit Metropolitan Wayne County Airport (DTW)
Air Traffic Control Tower (ATCT)
Building 801 Romulus, MI 48242

Project Reference Number:
A105952, S116930, P116941
Report Date: February 1, 2005

Federal Occupational Health
a component of the U.S. Public Health Service
Department of Health and Human Services



I. INTRODUCTION

At the request of Federal Aviation Administration (FAA) the U.S. Public Health Service (USPHS), Federal Occupational Health Program (FOH) conducted a visual assessment of the FAA Air Traffic Control Tower (ATCT) facility, located at the Detroit Metropolitan Wayne County Airport (DTW), Building 801 in Romulus, MI 48242. This request was made in response to Indoor Air Quality (IAQ) concerns and reports of possible exposure to fungal contaminants from previous mold abatement activities. On February 1, 2006, Mr. Stephen Lindsey, under the direction of Captain Douglas C. Pickup, MS, CIH, REHS, performed a visual inspection and assessment of the entire DTW ATCT. This assessment also focused particular attention on conducting an in-depth visual examination of the facility's elevator shaft relative to potential fungal growth or ongoing moisture problems. In addition to the visual inspection and assessment, several FAA site employees were interviewed and numerous reports and documents were reviewed relative to past conditions, mold remediation activities and fungal sampling that have taken place in the facility. This work was conducted under an Inter Agency Agreement (IAA) between FAA and FOH.

II. BACKGROUND

The ATCT facility is a Leo Daily standard design; approximately 230' in height with a three level base building constructed in 1990. The ATCT shaft is constructed of both load bearing pre-cast and cast-in-place concrete panels. The floors at all levels are composite decks on steel frame. The upper levels (occupied) are constructed of structural steel frame with architectural pre-cast panel cladding. Interior walls throughout the facility are gypsum wallboard on metal stud framework. Fire rated gypsum wallboard covers the wall surfaces within the stairwell, cable and mechanical chases, and within the central elevator shaft.

It appears from review of past documentation, that numerous IAQ and mold evaluations have been conducted in the facility by various parties. During 2005 several significant activities took place with subsequent reports being prepared, relative to mold growth and fungal exposure issues in the facility. From reported data initial fungal remediation was conducted in January 2005. A subsequent fungal remediation project was conducted at the facility in May of 2005. This work was completed by MIS Corporation (MIS) under contract to the FAA and the work was overseen by Clayton Environmental Group (CEG). These remediation

efforts involved removal of fungal contaminated wall board. At the conclusion of the May 2005 remediation activities, CEG conducted air sampling for mold and fungi in the facility. This was done to assure that the remediation activity had not resulted in an elevated concentration of airborne viable organisms in the structure; and that upon conclusion of all remediation efforts and all cleaning and re-cleaning, airborne fungi in the facility were significantly less than outdoor concentrations and that fungal species found inside the building were consistent with those found outside the structure. The results of the sampling conducted in the building on May 21, 2005 as reported by CEG found that the "average outdoor concentration.....is approximately 24 times greater than indoor concentrations" and that "the biodiversity of the fungal taxa identified on the 9th Floor...was similar to that identified in the samples collected outdoors".

Following these projects and activities, a Moisture Assessment Report was completed in August 2005. This assessment was conducted by Jacobs Facilities Inc. (JFI). The report from this assessment "identified a small amount of mold growth in a few localized areas of interior surface gypsum wallboard in the elevator shaft liner, primarily at levels 6-9 of the ATCT. The mold was observed on the surface paper of the wallboard and did not appear to penetrate the surface". The report goes on to note that some dry water stained areas were observed in the elevator shaft "but no mold growth was apparent". At the conclusion of this assessment JFI concluded that "the minor mold conditions noted on a few areas of the elevator shaft wall does not appear to pose a health concern to the occupants..." The report does recommend some surface cleaning activities to remove any old mold growth and water stains, as well as ongoing visual inspections to assure that no reoccurring moisture or water infiltration is occurring in the building and that no additional mold growth is occurring. Additional mold evaluations or clean-up work may have been conducted in the building; however, FOH did not have access to any additional reports or data of such efforts.

Following review of the past materials and reports concerning the structure, FOH traveled to the ATCT and on the evening of February 1, 2006, conducted an in-briefing with the FAA Regional Safety & Health Manager, Mr. Wayne Vogelsburg, Certified Industrial Hygienist (CIH); DTW Facility Operations Manager, Mr. Steve McClinchey; and the DTW Facility Manager, Ms. Monica Keyes. Following the in-briefing, a walk-around of the exterior of the building was conducted and a floor-by-floor walk-through of the interior of the facility was completed to examine all areas

of concern. During this walk-through measurements for temperature (T), Relative Humidity (RH), carbon monoxide (CO) and Carbon Dioxide (CO₂) were conducted. Moisture content measurements were performed on wallboard throughout the structure and elevator shaft. In addition an inspection was conducted of the facility Heating, Ventilation, and Air Conditioning (HVAC) systems and mechanical rooms. Following the walk-through of the facility, an inspection of the elevator shaft was completed at 10:00 pm. An out-briefing was held with the above mentioned staff and the NATCA Consultants CIH and NISC contractor, Mr. Mousa Abuzir. During this out-briefing the safety of the shaft in regards to fungal contamination and employee health concerns was discussed. At that time it was conveyed to the NATCA representative that in the opinion of FOH there was no apparent conditions that would be adversely affecting the health of the FAA employees in the facility or the NATCA representatives conducting the inspection of the facility. This was done prior to the NATCA representative's inspection of the elevator shaft later that evening.

III. FINDINGS

A. Facility Exterior. During the inspection of the exterior of the building, several areas were observed where water infiltration could occur in the building. This included the following areas:

1. On the Cab floor level while accessing the Catwalk, it was found that the caulking used to seal the expansion joints of the exterior cast-in-place concrete panels was weathered and separating from the concrete panels. This caulking was thinly applied resulting in the creation of a gap of approximately 1/2" to 3/4" between the expansion joints and concrete wall panels, exposing the foam-backing rod in several areas around the catwalk. The applied caulking was also insufficient to fill the void between the exterior of the building and the foam backing rod.
2. In the areas of the Microwave Antennae Balconies on the junction floor, various penetration points where possible moisture intrusion could occur were observed, this included poorly sealed or caulked areas around joints, windows and floor drains.
3. Additional penetration points on the exterior of the facility where possible sources of moisture intrusion may be occurring included poorly caulked areas around exterior electrical outlets, security

lighting, cameras, doors, windows, and HVAC and utility penetrations and flashing.

In addition, evidence of where standing water or ponding had occurred was observed in several areas on the decking floor and in locations where pipe and cable penetrated thru the floor deck. Water staining and water trails were observed on the ceiling of the balcony from possible wind and heavy or driving rains.

B. Facility Interior. A walk-through of all floors and a visual assessment of all areas which had previously undergone mold abatement was conducted. During this walk-through assessment of the following environmental conditions were recorded:

1. Temperature (F°) in the facility ranged from 64 F° to 72.5 F°;
2. Relative humidity (RH) averaged between 31% and 35%;
3. Carbon dioxide (CO²) concentrations ranged between 648 and 660 parts per million (ppm); and
4. Carbon monoxide (CO) concentrations were at 0 ppm.

These IAQ measurements were collected using a TSI Q-Track™ IAQ Monitor, Model 8554. CO² is measured using a Non-Dispersive Infrared (NDIR) sensor with a range of 0-5000 ppm. It is accurate to +/-3% of the reading +/- 50 ppm at 77 F°, and has a resolution of 1 ppm. Temperature is measured using a Thermistor sensor with a range of 32 to 122 °F, an accuracy of 1.0 °F, and a resolution of 0.1 °F. Humidity is measured using a thin-film captive sensor with a range of 5 to 95% RH, with an accuracy of +/- 3% RH and a resolution of 0.1% RH. This unit is factory calibrated annually and calibration checks are conducted prior to each use.

All of the measurements taken for F°, RH, CO² and CO were all well within acceptable guidelines for Indoor Air Quality as established by the American Society of Heating, Refrigerating and Air-conditioning Engineers (ASHRAE) and the American National Standards Institute (NIST). Detail of these recommended standards can be found in NIST/ASHRAE publication Standard 62.1-2004.

Visual observations of the areas where past mold abatement had taken place along with review of the documents provided by FAA and interviews with the facility staff, found that all appropriate methods and measures were followed to ensure the health and safety of the federal

employees in the facility during the abatement activities of affected gypsum wallboard on the 3rd, 4th and 9th Floors.

During the various abatement projects approximately 2' of water damaged and/or mold contaminated wallboard was removed above the floor decking. From our evaluation it was found that when new wallboard was installed in the abated areas, it was done so in a manner that has the wall board in direct contact with the floor decking in many areas. This direct contact allows for a "wicking" of moisture between the wallboard and the floor to occur should the floor become wet or if gross moisture intrusion were to occur in these areas. Typical installation allows a 1/2" to 3/4" gap between the bottom of the wallboard and the floor, providing for a natural moisture barrier between wall and floors.

Dried moisture staining was observed on the structural beams and wallboard along ceilings on the interior walls on many of the floors. These signs of moisture intrusion appear to be similar in size and location on all floors and are confined to the interior core walls of the structure. Similar signs of staining can be found within the elevator shaft in similar locations. The exterior walls are of concrete and were free from staining. In the interviews with the facility staff there was no known or recorded occasions where flooding or significant water damage had occurred in the facility.

During the survey moisture readings were made on wallboard surfaces throughout the interior of the facility. Special attention was placed on making readings in water stained areas or where there appeared to be past moisture problems. All of the measurements taken indicated that the current moisture content/levels within the wallboard materials in the facility were well below alarm levels (<0.05% moisture content). These measurements demonstrate and indicate that the condition of wallboard during our assessment was essentially dry.

Moisture readings were collected with the use of a Delmhorst *MoistureCheck* moisture meter. This unit is factory calibrated annually and calibration checks are conducted prior to each survey. The operation of this unit is based upon resistance technology to display reading as a percent moisture content value in the "pin" mode or on a relative scale in the "scan" mode. The *MoistureCheck* operates on the principle of electrical resistance. It uses building materials such as wood or gypsum wallboard as the element in a circuit by driving two electrode pins (pin mode) into it or touching (scan mode) the *MoistureCheck* sensor unit on the building material. Scan mode is used to estimate the relative moisture

levels in various building materials through non-invasive contact. The meter sends a signal through the material being tested and responds to an electromagnetic "echo" (Copyright 2005, Delmhorst Instrument Co. 9). The feedback is displayed in terms of a numeric, *relative value* over the range of 0-200, where lower readings indicate drier conditions than higher readings. This information helps the user determine if a moisture problem exists, and whether to proceed with more extensive pin meter measurements (Pin Mode). The "ALARM" feature in the meter provides the user with a set point, at which readings above a specified value (considered "WET" or unacceptable) generate an audible alarm. Threshold values range from 0.05% MC to 39.5% MC in the "pin mode" and 150 on a relative scale in the "scan mode"

All records and visible observations indicated that the facility is very well maintained and operated. All unoccupied areas of the ATCT were found to be clean and free of house keeping issues.

C. Elevator Shaft. The observation of the elevator shaft was conducted with the Elevator Maintenance Contractor (hereafter referred to as the Operator) operating the elevator from the roof of the elevator car traveling from floor to floor beginning at the CAB level. The shaft wall surface is covered with unpainted "Fire Rated" gypsum wallboard. Located at the floor levels within the shaft are several areas of visible moisture staining and water trailing. This staining or trailing begins at each of the floor decks and travels down to the next floor, with visible signs of dried mold growth at approximately 2' to 3' around the floor deck. This dry or dormant visible fungal material within the shaft is what would be considered minimal in size in any one area. The approximate size of these areas range from a ½" spot to an area covering approximately 2 to 3 square feet and is found at approximately 2' to 3' above or around the floor level. This finding along with the similar signs found on the interior walls is typical of what would be found in a building that has been involved in a flooding event. This flooding event could have occurred as a result of a heavy rain during construction of the building prior to completion of a sealed roof or cap; or as a result of a leaking or damaged main water line, HVAC chill water line or facility fire suppression system. However, there are no current signs of any ongoing water infiltration or leaking.

As with the interior wallboard of the facility, moisture readings were conducted on numerous areas of the fire rated wallboard in the elevator shaft. Again these reading indicated moisture levels well below the

MoistureCheck alarm level (<0.05% moisture content) indicating essentially dry wallboard.

At the ceiling level of several floors within the shaft a small HVAC supply and return was found, reportedly dedicated to the elevator shaft to temper the environment of the shaft. These supply and return ducts were found to be clean and free from dust, debris, and fungal growth. The elevator shaft pit was clean and free from debris.

In the interview with facility staff, there were reports and concerns that the size of the fungal affected areas within the elevator shaft were growing and becoming darker. By interviewing the Operator while inspecting the shaft, it was discovered that this information originated with the Operator and was conveyed by him directly to the FAA staff. While the intentions of the Operator were good, his estimations of the effected mold growth areas were conducted in a size restricted area with limited light and visibility. This coupled with his lack of experience and training in indoor mold issues and due to the fact that he is not a trained and qualified environmental professional, resulted in the transfer of inaccurate information concerning the areas of concern. It is the opinion of FOH that these areas of old mold growth are not currently viable or "growing". This conclusion is based on observation of the areas and due to the fact that all measurements indicate that wallboard throughout the facility and in elevator shaft is currently very dry and there is no evidence of an ongoing source of moisture which would be required by all fungal organisms to remain viable.

D. HVAC. The HVAC units were found to be clean and free of debris and moisture and drain pans were dry and biocide tablets were in place. Records indicated that all HVAC filters are changed on a quarterly basis and were clean and free of debris at the time of our assessment. All HVAC and floor drains were clean and free of debris. The second floor Mechanical/HVAC Room was found to have had flooding due to a "pop-off valve" failure. Verbal and visual findings of this incident indicate all appropriate measures were conducted to clean-up and abate any water-damaged materials. Gross water was removed, gypsum wallboard was dried by removing base cove and drilling 1" holes approximately 2" above floor level, an industrial air mover and dehumidifiers were placed throughout the area to remove moisture from wetted material and indoor air. The HVAC room and surrounding areas were cleaned and dried within 24 hours. It appears that all appropriate measures were followed to abate this issue.

IV. Conclusions

As a result of the evaluation conducted by FOH prior to and on February 1, 2006 at the FAA DTW ATCT it is concluded that a gross moisture intrusion event occurred at some point in the past and was associated with the majority of the floors around the core of the building. This conclusion is based on the water staining in similar locations on the interior walls and within the elevator shaft. This moisture intrusion resulted in water damaged building materials and signs of artificial mold growth inside the structure.

It is further concluded from the assessments, reviews and interviews conducted, that the remedial activities to abate the water damaged building material and fungal issues at the facility were conducted properly and within "Best Practice" of the FAA and contract industrial hygiene professional involved in these efforts. Since there are no federal regulations regarding the issue of fungal contamination and or exposure levels, the industry follows various guidelines such as the New York City Department of Health 2004 Guidelines for Assessment and Remediation of *Stachybotrys atra* in Indoor Environments; and Remediation of Microbial Contamination and Bioaerosols - Assessment and Control issued by the American Conference of Governmental Industrial Hygienists (ACGIH). It is the opinion of FOH that these industry standard guidelines were followed during all remediation activities conducted by FAA at the ATCT. These guidelines indicate that the remedial activities can be safely conducted by maintenance workers without any containments or precautionary measure for areas less than 32 square feet (ft²) of visible fungal contamination. From the reports and interviews, the areas of fungal were just at or below the 32 ft² in any one location. Despite this fact, the efforts conducted during the abatement activities at this ATCT utilized negative air containments, personnel protective equipment (PPE), and followed the removal practices in New York guidelines for all work conducted even though many of the areas were less than the 32 ft² of contamination.

Following all remediation activities, records indicate that comparative air sampling was performed to clear the containments, demonstrating that the fungal burden within the containments was significantly less than the fungal burden outside of containment and in the outdoor environment. Mold of all species can be found everywhere; there is not a standard or established level to determine what is an acceptable airborne level of mold or fungi. In the abatement process, the goal is to abate the affected area in a controlled environment to manage gross release of

fungus spores and debris, thoroughly clean the containment; and then use sampling and analysis along with the oversight of the events to determine if the efforts have been successful. The analysis interpretation must be done by a qualified professional in order to make the determination that the efforts were successful and completed according to industry standard protocols. In review of all data provided, these abatement activities were successful. The ongoing daily effort of FAA in the monitoring and inspection of the facility for water damage or fungal growth is in line with FOH standard recommendations and follows "Best Practice" of the profession.

The reports of gross fungal contamination from the abatement activities within the facility are very difficult to determine as all remedial efforts appear to have been conducted properly. In addition any remaining fungal debris within the elevator shaft is minimal in an area non-accessible to employees. Airborne sample results taken following the last abatement event, indicate that airborne fungal concentrations inside the ATCT were 24 times less than the concentrations found outside the Tower and that the biodiversity of the organisms found inside the building and outside the facility were similar. It is our opinion that if this sampling were conducted at this point in time the results would be similar; in that the airborne fungal concentrations inside the facility would be significantly less than those found outside the structure and that the biodiversity of the types of fungi present would be similar or consistent.

Environmental data collected inside the ATCT indicated that air quality and ventilation inside the structure is acceptable. Each facility mechanical system is properly maintained and working effectively. All drywall materials and other building components were found to be dry and in good condition. The facility was clean, well organized and maintained and free of clutter.

Several locations and areas were identified as noted above where water infiltration might be able to occur. This was primarily due to old or deteriorated caulking which needs to be replaced. Despite these minor areas of possible moisture infiltration, there is no evidence to indicate that there are any ongoing water problems or mold growth inside the structure.

In summary, the abatement activities conducted at this facility were performed properly and in a safe manner to ensure the health and safety of the federal employees. This facility was found to have excellent housekeeping practices in place, is properly maintained and was found to be one of the cleanest FAA facilities FOH has inspected to date. It should also be noted that during our evaluation it was observed and demonstrated on numerous occasions, that the health and safety of the federal employees within this facility was and is the foremost priority of FAA management.

V. Recommendations

- A. Continue to document and map all moisture intrusion events.
- B. On occurrence of moisture intrusion, determine and correct the source of moisture infiltration. Abate any affected areas following properly developed and approved procedures using qualified and environmentally trained personnel.
- C. Monitor and oversee all future fungal abatement activities from development to completion with proper documentation.
- D. Utilizing a HEPA vacuum, vacuum all surfaces within the elevator shaft under negative pressure and monitor for new occurrence of fungal growth. Should the decision be made to encapsulate these walls, verify any product used to assure that the integrity and "Fire Rating" status of the walls is not compromised.
- E. Educate, and inform employees of ongoing fungal abatement activities within the facility.
- F. Investigate the facility link between the terminal and the FAA to determine the +/- pressure effect to the FAA.
- G. Inspect and repair all expansion joints for failing caulking. Review data on replacement materials to ensure proper materials are utilized in repair efforts.
- H. Correct gypsum wallboard in contact with decking floor that would allow a "Wicking" to occur should gross moisture intrusion occur.
- I. To reduce the potential for microbiological growth in the facility, the relative humidity should be adjusted and maintained within the ASHRAE recommended range of 30% to 60%.

VI. Documentation Review

- A. DTW ATCT Investigation Report Consolidation dated March 30, 2005.

INDOOR AIR QUALITY/FUNGAL
Visual assessment and Consultation
Detroit Metropolitan Wayne County Airport (DTW)
FAA Air Traffic Control Tower (ATCT)

- B. Clayton Group Air Sampling and Consultation during Remediation of Fungally-Contaminated Gypsum Wallboard dated July 29, 2005.
- C. DTW ATCT Moisture Assessment report dated August 2005.
- D. DTW ATCT Monthly Visual Walkthrough Inspection Checklist Reports dated January 25th to 27th, 2006.

10

National Design and Design/Build
Services Contract
Contract DTFA01-02-C-00204

ATCT at Detroit Metropolitan Wayne County Airport - DTW



Delivery Order 07

Moisture Assessment Report

August 2005



MOISTURE ASSESSMENT REPORT

**THE ATCT AT
DETROIT METROPOLITAN WAYNE COUNTY AIRPORT**

(DTW)

ROMULUS, MICHIGAN

August 31, 2005

| TABLE OF CONTENTS | | PAGE |
|-------------------|---|------|
| 1.0 | EXECUTIVE SUMMARY..... | 3 |
| 1.1 | GENERAL..... | 3 |
| 1.2 | BACKGROUND..... | 3 |
| 1.3 | CONCLUSIONS..... | 3 |
| 1.4 | ROUGH ORDER OF MAGNITUDE (ROM) - COST ESTIMATE..... | 4 |
| 2.0 | OBSERVATIONS..... | 5 |
| 2.1 | INTRODUCTION..... | 5 |
| 2.2 | OBSERVATIONS AND RECOMMENDATIONS..... | 6 |
| 2.2.1 | ARCHITECTURAL..... | 6 |
| 2.2.2 | MECHANICAL..... | 7 |
| 2.2.3 | ENVIRONMENTAL..... | 9 |

APPENDIX

- TAB 1 PHOTOGRAPHS
- TAB 2 ROM COST ESTIMATE SCHEDULES
- TAB 3 SITE VISIT ATTENDANCE LIST

1.0 EXECUTIVE SUMMARY

1.1 GENERAL

The Moisture Assessment Report is hereby submitted for the Airport Traffic Control Tower (ATCT) at Detroit Metropolitan Wayne County Airport (DTW), in Romulus, Michigan. It has been prepared in accordance with the Scope of Services developed for this task under the Jacobs' Change Proposal CP 007-032A, dated May 26, 2005, approved June 15, 2005.

The objectives of this report include collecting sufficient data to perform a qualitative evaluation of excess moisture evident within the tower portions of the facility, resultant damage, and measures necessary to prevent or correct it, and generate a Rough Order of Magnitude (ROM) construction cost estimate for those corrective measures.

1.2 BACKGROUND

The ATCT is a Leo Daly standard design; approximately 230' in overall height, with an attached 3 level base building was constructed in 1990. The ATCT shaft is constructed of both load bearing pre-cast and cast-in-place concrete panels. The upper occupied levels are constructed of structural steel frame with architectural pre-cast panels cladding. The floors at all levels are concrete composite decks on steel frame. Interior partitions throughout the facility consist of gypsum wall board on metal studs.

1.3 CONCLUSIONS

The environmental survey observed small amounts of mold growth in a few localized areas on the interior surface of gypsum wallboard of the elevator shaft liner, primarily at levels 6-9 of the ATCT. The mold was observed on the surface paper of the wallboard and did not appear to penetrate the surface. We also observed some dry water stains in a few areas in the elevator shaft, but no mold growth was apparent. At this time, the minor mold condition on a few areas of the elevator shaft wall does not appear to pose a health concern to the occupants, but should be addressed in the near-term by cleaning the surfaces with a bleach solution, as recommended in this report, to remove the mold, and to mitigate additional future growth. Then, periodic visual inspections (monthly or quarterly) are recommended to reassess, identify, and address any additional mold growth in a timely manner. It is also recommended that other areas in the building that may have high probability of being a recurring moisture source (leaky pipe/valve, malfunctioning ventilation equipment, blocked drain, condensation, etc.) be included in the periodic visual inspection.

The architectural survey identified a number of possible contributing factors to excessive moisture and moisture related damage found in the ATCT. These factors include location and placement of gypsum wall board (GWB) panels, possible water infiltration and migration at and through the pre-cast concrete (P/C) panel joints, and water penetration at concrete slab edges. We recommend correction of these conditions to prevent and avoid recurrences of moisture related problems.

The observed mold on the elevator shaft liner does not compromise the fire-rating of wall construction.

The mechanical survey found that the cooling systems appeared to be in working order. However, the tower is under negative pressure; the HVAC system brings in moisture-laden outside air, and operates on

economizer cycle which is in violation of FAA Orders 6480.7C & D. The vestibule ventilation system is not currently operating. The building automation system is un-reliable, has aged beyond its useful life, out of calibration, and the local staff should be provided adequate training on its operation. Hence, the recommendation is made to install a new cooling coil in the outside air intake of vestibule ventilation system, revise the HVAC operation to a non-economizer operation, and provide a new building automation computer with proper training.

The observations, recommendations, and ROM cost estimate contained in this report reflect a professional assessment of the condition of the facility related to the problems investigated, and the probable costs to mitigate the observed deficiencies in the facility and prevent further occurrences. They are based on good professional practice and judgment.

1.4 ROUGH ORDER OF MAGNITUDE (ROM) - COST ESTIMATE

The ROM construction cost estimate to implement the recommendations of this report by a general contractor is \$489,793. It includes, in addition to labor and material, general conditions, mobilization and demobilization, small job premium, general contractor (GC) overhead & profit and bond costs. It should be noted that the majority of the cost is in the re-sealing of the vertical caulk joints of the P/C concrete panels at the "flare" of the ATCT shaft due to the difficulty of executing this type of work. While interior sealing may be performed at potentially lesser cost, it will provide limited surety of access to all locations, and effectiveness in dealing with the issues. The ROM cost schedules are included in the appendix.

There are additional costs associated with carrying out these construction projects that should be included for budgeting purposes. Such costs include A/E design fees for each project, associated A/E construction administration support (shop drawing review and responding to field RFIs), and F&E plant costs borne by the FAA in supporting the construction project(s).

2.0 OBSERVATIONS

2.1 INTRODUCTION

Jacobs's survey team comprised an architect, a mechanical engineer, and a certified industrial hygienist (CIH) environmental engineer performed a site visit to the facility on Tuesday and Wednesday, June 21 and 22, 2005. A sub-contracted skilled laborer accompanied the team to assist with any intrusive exploration required within the facility.

The goals and level of effort of the site survey consisted of the following:

1. Gather field data to assist in performing an objective qualitative multi-discipline evaluation of the existing conditions, and note obvious pertinent deficiencies as encountered and collect data for use in developing this report.
2. Meet with regional FAA personnel to solicit their input on the current condition of the facility, remediation efforts previously undertaken related to the problems observed, and to report the field observations and address the deficiencies in this report, as indicated above.
3. Provide sufficient data to generate a Rough Order of Magnitude (ROM) cost estimate, as required to remediate the deficiencies noted in the report.

The construction documents made available indicate the ATCT is a 207'-0" (to cab floor) Leo Daly standard design. Prior to conducting the site visit, Jacobs obtained a copy of some of the design drawings for the ATCT from the FAA Great Lakes Regional office, and some additional documents were obtained at the site.

A coordination meeting was held at the facility on Tuesday afternoon, June 21, 2005 at the ATCT with FAA and Jacobs representatives. The actual survey began Tuesday evening and was started with an attendance and safety meeting. The attendance list from both coordination and the pre-survey meetings are included in the Appendix.

In order to minimize impacts to facility operations the team surveyed the full height of the elevator shaft during the night hours of Tuesday, June 21st. The elevator roof hatch was opened and the interior of each level of the shaft was observed from a ladder placed inside the elevator cab, where pictures and notes were taken by all disciplines. Later the survey team surveyed the fourth and ninth floors to investigate the source of the moisture reported there by the FAA.

On Wednesday morning, the team returned to the ATCT and surveyed each level to further investigate any possible sources of moisture.

During the survey, Jacobs conducted a limited visual inspection of observed mold growth. Jacobs did not conduct any mold sampling.

2.2 OBSERVATIONS AND RECOMMENDATIONS

2.2.1 ARCHITECTURAL

General

The Architectural survey focused on identifying any potential sources of moisture penetration into the ATCT, the resulting damage, and recommendations to repair and mitigate those conditions. Both the building envelope and interior construction were observed in order to define the extent of any physical deficiencies contributing to the problems of moisture within the building. Described here-in are the architectural observations and the recommended solutions to the noted deficiencies.

A. Observations

1. In some interior spaces, specifically the 4th and 9th floors in the ATCT, the FAA had found moisture or mold at the bottom of gypsum wallboard panels (GWB), and had removed and replaced the affected GWB to a height approximately 3'-0" above the floor. This includes GWB along the exterior walls, interior partition walls and the outer layers of the gypsum board shaft liner surrounding the elevator shaft. There are a number of concerns regarding the existing conditions of the GWB, including the replacement portions.
 - a. Much of the new GWB has been placed in direct contact with the concrete floor slabs, to match existing GWB. This allows for "wicking" of any condensation or moisture present on the floor into the panels causing further water damage and decay of the gypsum board.
 - b. In accordance with the building codes, the intermediate shaft levels (1-10) below the Sub-Junction Levels the "Leo Daly" standard ATCT are to remain "unoccupied". At DTW, levels 3 through 10 have been built-out as storage and offices spaces, creating non-compliant "occupied" spaces. The moisture problems identified in this survey typically manifest themselves at areas within these levels.
 - c. Visual inspection of the elevator shaft revealed minor surface mold growth on the interior shaft-liner at levels 6 through 9. This growth is primarily found on the GWB panels above the floor slab and partition sill track. Additionally, some surface corrosion was observed on these sill tracks, further indicating the damage may be a result of moisture at the floor slab.
2. A number of existing conditions were observed at the exterior envelope of the occupied junction and existing sub-junction levels that may have contributed to the moisture found at the lower levels.
 - a. The joints between the pre-cast panels at the "flairs", above the vertical tower shaft on levels 10 through 13 (cable access), have what appear to be urethane type foam caulk joints. These joints show significant signs of deterioration. The joints on the interior face of these same panels have a solid non-flexible sealant material that shows no sign of failure or water leakage. The space between the inner and outer sealant lines could not be observed, it is however possible that water could migrate between these lines to the lower levels of the tower shaft.
 - b. A possible source of moisture infiltration was observed at the Microwave Antennae balconies at the 10th floor Junction Level. At the south and west corner balconies the

floors are open metal grating above an interior areaway accessed from the Electronic Equipment Room. The floor drain located within the areaway of the west balcony shows evidence of past blockage and subsequent ponding of water. During the inspection this drain had some debris consisting primarily of the light-weight fireproofing from the surrounding steel structural framing, partially obstructing the drain. It can be assumed that the south balcony, which could not be inspected, is in a similar condition. The north and east balconies have bare concrete floor decks that, being exposed to the elements are potential source of moisture penetration particularly at the outboard deck edges.

B. Recommendations

1. In order to mitigate observed problems and return the ATCT to code compliance, all non-rated internal partitions and associated doors, frames, and hardware within the tower shaft defining "occupiable spaces" should be removed (approx. 1100 square feet, 9 doors and frames).
2. In the affected areas not addressed by the previous comment, the bottom edge of gypsum wall board should be cut back approximately $\frac{1}{4}$ " above the floor slab to prevent wicking of moisture into the panel. At rated assemblies, an appropriate UL approved, fire rated sealant should be installed between the slab and GWB. A rubber or vinyl wall base should also be installed to conceal the cut (approx. 30 linear feet).
3. The shaft liner panels within the elevator shaft should be wet-wiped cleaned and may be painted in a manner described in the environmental observation portion of this report (approx. 6100 square feet).
4. All vertical exterior pre-cast panel joints should have the sealant joints stripped, and appropriate new backer rod and sealant installed (approx. 1300 feet).
5. The concrete decks at the north and east and below the south and west microwave balconies should have a fluid applied waterproof traffic membrane installed, with particular attention paid to the perimeter slab edge where leaks are most likely to occur (approx. 600 square feet).

2.2.2 MECHANICAL

General

The existing mechanical system of the ATCT was reviewed as it relates to the reported moisture conditions. The review focused on how the system managed airborne humidity and ventilation throughout the tower and the elevator shaft. Special attention was paid to the fourth and ninth floors of the facility.

A. Observations

1. The HVAC system for the ATCT includes: air-handling units, chilled water cooling coils and hot water heating coils, exhaust fans, unit heaters, air distribution, HVAC control systems and instruments.

2. Two constant volume air conditioning units AHU-11 and 12 (one is a standby) located on the sub-junction level serve the offices and the electronic equipment room on the Junction level. Two constant volume air conditioning units (AHU-13 and 14, one is a standby) serve both the cab and restrooms. The stairwell vestibule is provided with a ventilation system which includes outside air intake plenum; supply fan and ductwork; return air ductwork; exhaust fan and discharge louver.
3. The fourth level storage room has had a water flood sometime in the past, according to the facility Staff. The bottom of the outside air intake and some separate small ductwork are located in this room. It is possible that the flood was due to the water accumulation in the outside air plenum and seepage from the small ductwork. This water could have gone undetected, ponding up in the room and wetting the gypsum wall board. This room is not ventilated although it is close to the vestibule. Measured temperature and humidity was 76 F and 46% RH.
4. The vestibule ventilation system could bring in moisture-laden outside air and distribute it throughout of the facility. This system was inoperative at the time of the survey. When the system is running there is no air balance in the facility. Supply air fan (SF-2) draws in and distributes 3525 CFM raw, untreated moisture laden outside air. Exhaust fan (SF-1) removes 5290 CFM air from the tower. That means that the tower is constantly under negative pressure. This is a violation to the FAA Orders 6480.7 C & D, which requires that the facility should be under positive pressure all the time.
5. The survey did not reveal other indications of water coming from any plumbing system.
6. The ninth floor storage room has no ventilation. Temperature and humidity were 76 F and 46% RH. There was no evidence of moisture from any mechanical or plumbing system.
7. The tenth floor NATCA room was previously used as a smoking room. It has a de-energized exhaust duct/fan system. Make-up air is provided from the stairwell vestibule supply air ductwork. There was a self-contained portable room air conditioner operated in this room, but presently it is disconnected. The room does not have any ventilation and the temperature was 74.5 F., and humidity 55% RH.
8. At the sub junction level several ceiling tiles were removed; no indication of damage from the plumbing system above the ceiling was found. Temperature and humidity were 69.5 F and 56.8% RH. On the north corner balcony of the ATCT we found evidence that some time ago there was a drain pipe burst (confirmed by the ESU Staff) and the discarded elbow is still on the floor. Also found was a rotten cardboard box over the floor drain indicating that the floor has been flooded at some point in time, possibly resulting in water seepage into the tower shaft's interior.
9. Several ceiling tiles were removed in the Junction Level to observe possible water seepage protrusion from above, and none was found. Room temperature was 72 F, humidity was 55% RH.
10. The cab level AHU system operates in the economizer cycle mode when weather permits. This system brings in untreated moisture-laden air into the facility. This is a violation of FAA Order

6480.7C & D which prohibits economizer cycles for critical operational areas such as the cab, electronic equipment rooms and TRACON.

11. The building automation computer system is malfunctioning and its temperature sensors are out of calibration beyond its useful life. The computer is an old 362 system, which can't pull-down menus or print trend reports. The computer operators do not have sufficient training to operate or adjust system functions.
12. Outside air intake louvers are clogged-up with dirt and need cleaning.

B. Recommendations

1. Reactivate the vestibule ventilation system and install a cooling coil into the ductwork to remove the moisture from the outside air. Revise air flow of SF-2 and SF-1, so that SF-2 will have a higher air flow than SF-1, thus putting the tower under positive pressure (positive pressure prevents untreated moisture and dust laden air entering into the facility).
2. Change the control system to prevent operation of the economizer cycle. Disconnect damper operators from return, economizer relief air, and outside air dumpers. Set outside air volume constant as per the number of occupants. Install a new building automation computer system and provide sufficient training in its use.
3. The entire ATCT HVAC system needs to be rebalanced to provide positive pressure at all times.
4. Close the air gap under the door to the ESD's area. Presently unconditioned moisture laden outside air enters to the ESD's control room increasing the loads on the newly installed AHU.
5. Recommend removal of the drywall from all the "storage" rooms in the tower.

2.2.3 ENVIRONMENTAL

The environmental assessment focused on evaluating potential moisture and mold sources. Typically, mold issues start with long-term moisture areas on sources of organic nutrients with prolonged temperature and humidity conditions that promote mold growth. Common moisture issues include, but not limited to, leaking valves, sweating pipes, condensation (hot and cold surfaces), rain/snow water infiltration, blocked drains, poor ventilation, mechanical maintenance, etc. Common sources of nutrients may be the cellulose in ceiling tiles or paper, carpet, etc. The heating, ventilating and air conditioning (HVAC) system plays an important role to control mold growth inside buildings.

There are five basic conditions that may raise the risk of mold growth:

1. Long-term moisture – most important
2. Temperature range between 40 – 100°F
3. High humidity – greater than 60%
4. Organic nutrient base

5. High concentration of mold spores

Some common conditions that may result in a mold issue include:

- a. Improper building ventilation and maintenance
- b. Mechanical equipment that is inaccessible, non-drainable, or non-cleanable
- c. Poor waterproofing, caulking, sheet metal details / workmanship that allows water infiltration
- d. Leaking water lines as a result of poor workmanship or damage
- e. Water damage of building materials prior to or after installation
- f. Plugged drains or inadequate drainage slope
- g. Frozen pipes due to inadequate insulation
- h. Improper design or installation of vapor barriers
- i. Inadequate slope to drain

A. Observations

As part of this moisture survey, Jacobs conducted a visual inspection of the accessible areas, above ceilings and behind walls, to evaluate current building conditions for moisture accumulation and possible mold growth areas. Jacobs did not conduct mold sampling.

1. During the initial building walk-through on Tuesday afternoon, June 21 and the late evening of June 21 through June 22, a wide range of temperature, humidity, and ventilation controls were noticeably different at various levels of the tower and fluctuated significantly from day to night time. On some levels the room conditions appeared to be directly dependent on outside weather conditions.
2. Discussions with the maintenance personnel indicated difficulty to control and operate the ventilation mechanical system. See Mechanical Section for details.
3. Throughout the tower, the rooms have concrete floors, and most have finished walls and ceilings. Some ceilings and walls are open to the pre-cast concrete steel structure. The structural steel is covered with spray-on fireproofing. On the non-occupied levels of the tower, there is no mechanical ventilation and stagnate air conditions were encountered in closed rooms. The elevator piston action does force air movement in the elevator lobby areas of each level, but adjacent rooms are closed and have minimal air circulation.
4. At various levels throughout the tower there were a few exposed spots of structural steel, such as near a pipe hanger or edge, metal surface corrosion was noticeable and indicated high humidity conditions have occurred in the space probably due to ambient weather conduction.
5. Most wallboard extends to contact the concrete floor. The metal stud walls are constructed of a gypsum wallboard, fiberglass insulation in walls along the exterior structure, and an interior thicker wallboard. Typically, there is approximately 8-12" of air space between the interior wall board and the pre-cast concrete structure exterior wall. No accumulation of moisture or mold was identified.

6. One small accumulation of moisture was identified behind a GWB column cover on the 9th floor, Room 928 northeast corner, but no mold growth was identified in the area. This area was directly behind the wallboard that was removed during the mold abatement in the spring 2005.
7. Prior mold remediation areas on the 4th and 9th floors were inspected and currently no mold growth was visible or detected by a musty odor.
8. Elevator Shaft – A small amount of surface mold growth was identified in a few localized areas of the upper elevator shaft (9th through 6th floors). The mold was identified only on the surface paper (green back) of a few wallboards lining the elevator shaft. The mold was identified on the surface paper and did not penetrate into the wallboard. The growth is primarily found on the wallboard panels above the floor concrete slab and metal partition sill track. Additionally, some minor surface corrosion was observed on these metal sill tracks, indicating damage may be a result of moisture at the floor slab. A direct cause for the current areas of minor mold growth on the elevator shaft walls was not determined. Since the elevator shaft draws air and vents to the outside atmosphere, changing ambient weather (humidity, temperature, etc.) conditions may affect the elevator shaft conditions to promote mold growth. Also in the elevator shaft, a few areas of minor, dry, water stains were identified, but no mold growth was present on the water stains.
9. One small water stained (8" diameter) on a ceiling tile was identified outside the Junction level Men's Restroom but no mold growth was present.
10. A surface, dry, water stain (1'x1') on the wall board was noted under a duct in Room 827 but no mold growth was present.
11. A few locations of dry, water stained pipe insulation were noted above a few ceilings, but no mold growth was visible.

B. Recommendations

The environmental recommendations emphasize preventing and reducing the risk of mold issues by using preventive maintenance checks, good building HVAC system operation and maintenance, and prompt repair of water damaged areas (within 48 hrs.). If visible mold growth, discoloration stains, or a musty odor is identified, the moisture source must be identified and eliminated to prevent recurrence. Each case needs to be assessed individually to determine specific sources and implement appropriate corrective actions.

1. Assess mechanical ventilation system and improve operational control.
Conduct a full assessment of the HVAC system to identify repairs and upgrades to properly control and operate the building ventilation in the tower. See the Mechanical Section of this report of detailed recommendations.
 - a. Inspect drains, mechanical drip pans and filters for proper drainage and installation.
 - b. Check cooling coils and drip pans frequently for microbial growth. Be sure drip pans drain properly.
 - c. Check interior duct linings, such as fiberglass or felts, for moisture and mold growth if water damage is reoccurring in specific locations.

2. Conduct routine visual mold inspections. Compile a list of locations to periodically inspect where mold has been identified and removed for recurrence or additional moisture accumulation. Also, include areas with high probability of being long-term moisture source that may sustain mold growth, such as leaking pipes/valves, poor ventilation, water damage, condensation, poor drainage, or areas of condensation. Inspections are recommended monthly for known mold growth areas and quarterly for other potential areas. If an area has a musty odor or mold is discovered, the condition should be dealt with immediately. During the visual inspection, it is highly recommended that special attention be paid to ceiling tiles, gypsum wall board, paper or cardboard, and other surfaces that may contain cellulose, since cellulose is a common nutrient source for molds to grow. Conduct periodic inspection of the building for the following indicators:
 - a. Evidence of water damage, i.e., stained ceiling tiles, etc.
 - b. Evidence of high humidity or condensation (i.e. sagging ceiling tiles, wet building or pipe insulation, damp walls, etc.)
 - c. Musty odors
 - d. Mold growth on cellulose-based materials (paper, wood, chairs, etc.)

If after implementing the recommended mitigation no future growth is observed the FAA may decide to change the frequency of the inspections.
3. Elevator Shaft walls. Clean the interior shaft wall surfaces by wet-wiping with a bleach solution (1 part bleach to 10 parts water). Although surface bleach cleaning may not prevent a mold problem from recurring; the FAA can implement a system of periodic monitoring to determine the effectiveness in preventing or limiting mold growth. Should the FAA determine the results unsatisfactory, and as it is recommended in this report long-term action may be considered. The long-term actions include thorough bleach cleaning and painting of the shaft walls. The shaft walls must be thoroughly dry before applying paint. To limit mold growth, paints containing zinc can be used to encapsulate the area *after* surface cleaning and preparation. Two possible paint products are SheildZ@Plus by Zinsser Co., and Foster 40/20@ by H.B. Fuller. NOTE: Do not paint or caulk over mold.
4. During periodic visual inspections, wet materials (ceiling tiles, drywall, etc.) may be discovered. The moisture source must be identified and corrected to prevent reoccurrence. Wet materials that appear to be free of mold should be dried within 48 hours using equipment such as fans and dehumidifiers. If feasible, wet materials should be removed and replaced. If mold growth is visible, contact qualified personnel to determine the best corrective action(s). The observation should include the cavity behind or under the material. It must be noted that concealed parts of drywall may remain damp allowing mold to grow, even when the surface appears dry.
 - a. The drying process may take up to six weeks. Installation of replacement building materials (e.g., carpet, sheetrock, paint) should be delayed until water-damaged materials are completely dry.
 - b. If the materials are wet for long periods of time, they should be removed and replaced. Drywall should be removed at least 12 inches past the edge of mold growth (some recommend 3 feet if large scale water damage) or 12 inches above the highest watermark

5. Remove gypsum wallboard where it is in contact with concrete floor to create a minimum ¼ inch gap between the concrete floor and wallboard to prevent moisture wicking.
6. Check and evaluate waterproofing at exterior joints, corners, and structure penetrations to prevent water intrusion
7. Check and ensure all chilled water and exterior drain pipes are properly insulated.
8. Where there is recurring water damage, check building utilities for leaks or improper installations.
9. Eliminate situations where moist, warm air is allowed to contact cool surfaces.
10. Maintain floor areas clean by periodic cleaning, and eliminate unnecessary clutter or storage.

APPENDIX 1
PHOTOGRAPHS

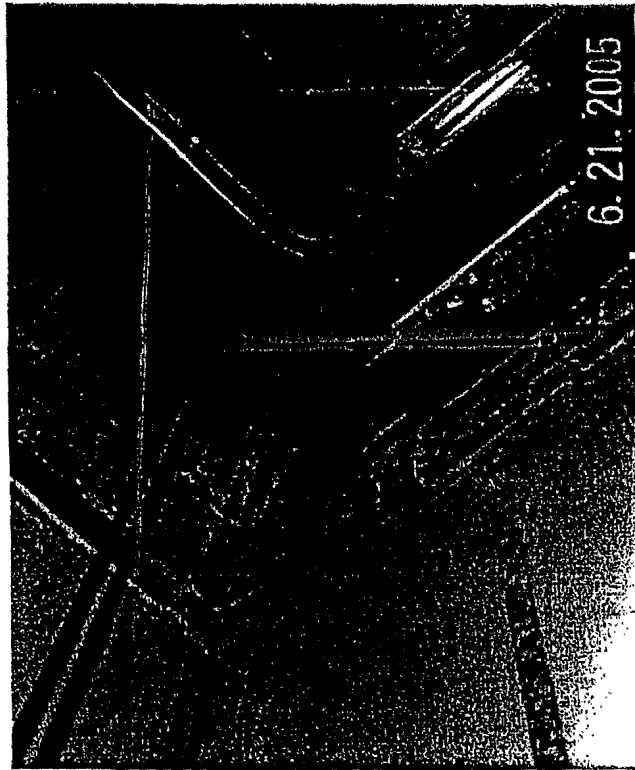

Surface corrosion on elevator shaft GWB liner panel sill-track indicating presence of moisture.

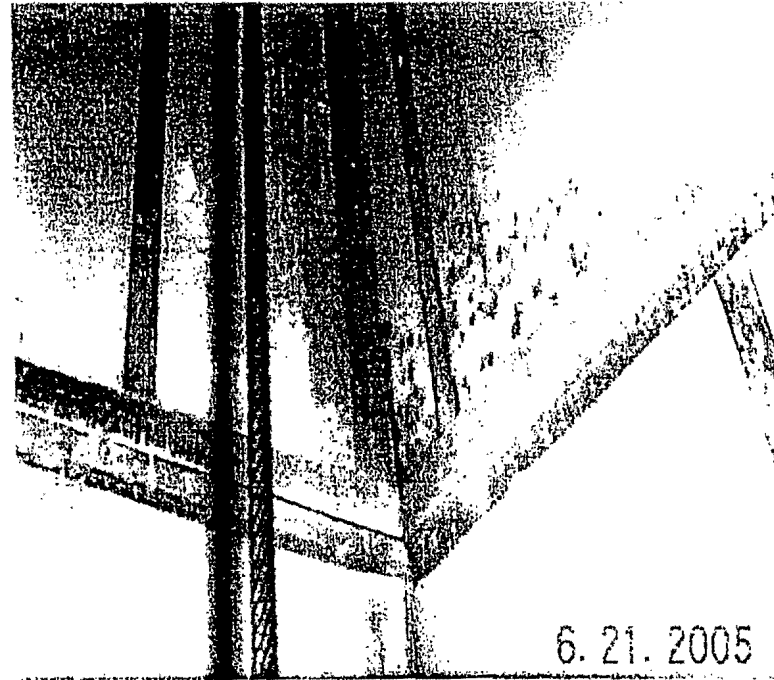

Minor mold on surface of elevator shaft GWB liner, just above the floor line.

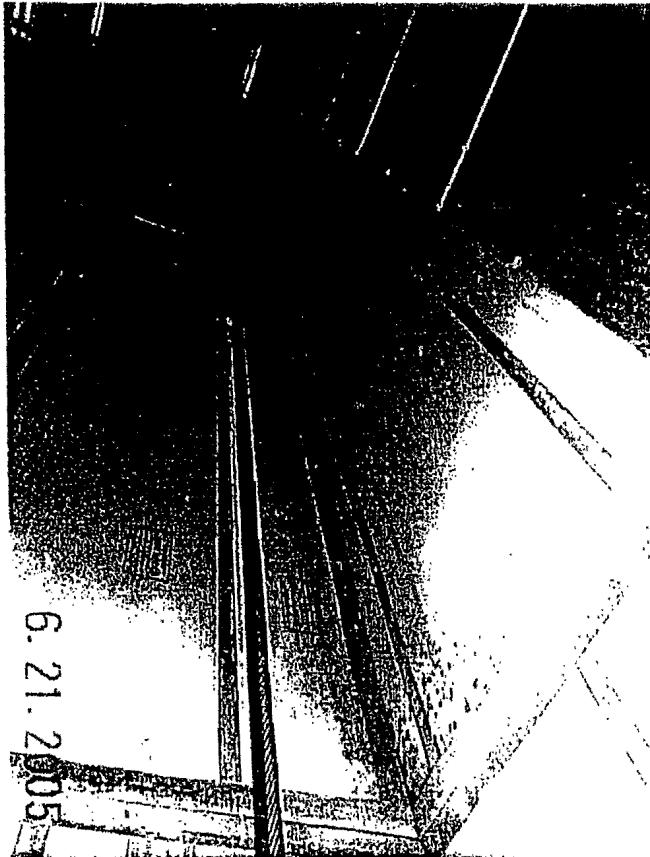

Minor surface mold on elevator shaft liner just above floor line.

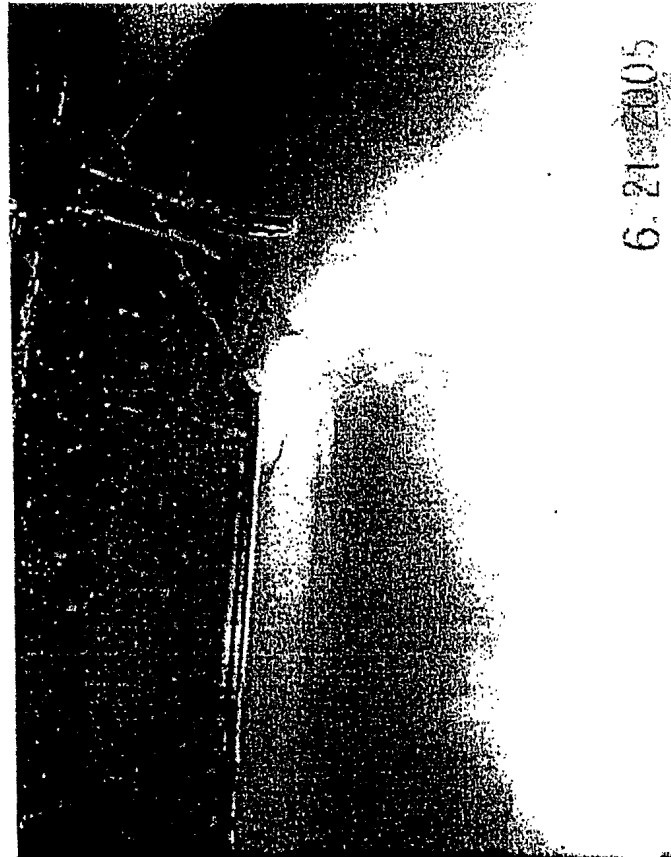

Water stains to gypsum wall board at mechanical ductwork at 4th level Storage Room.

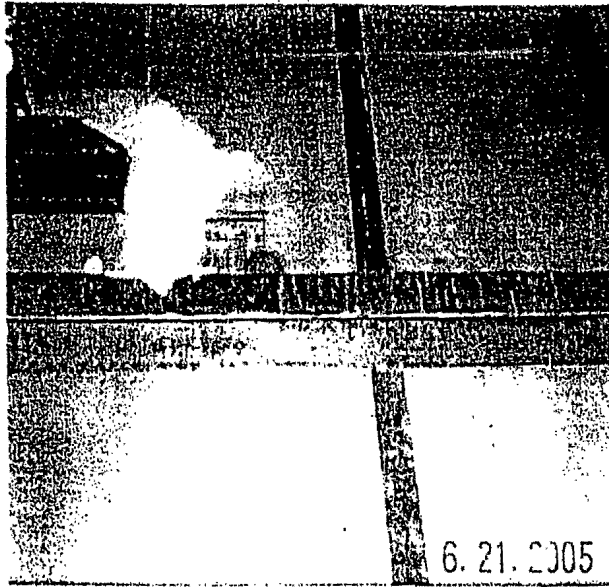

Minor surface mold on elevator gypsum shaft liner panel just above floor line.

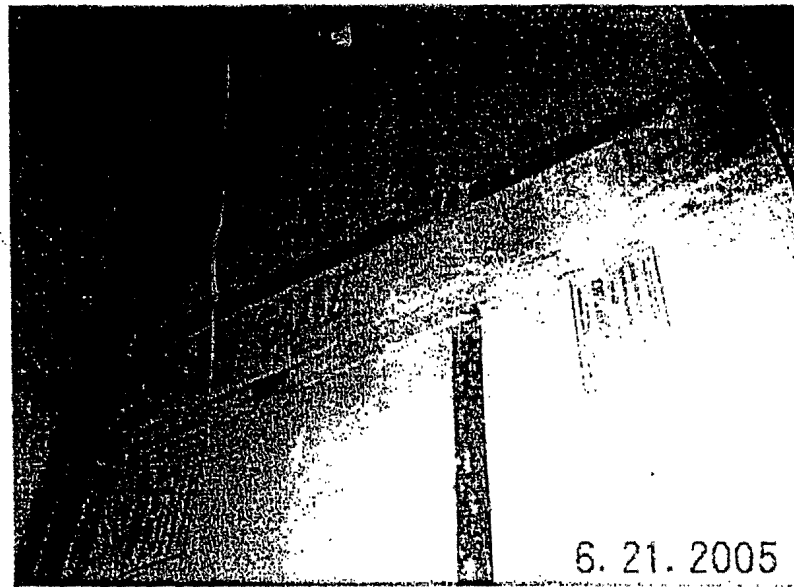

Minor surface mold and water stains on gypsum liner panel below floor slab location.

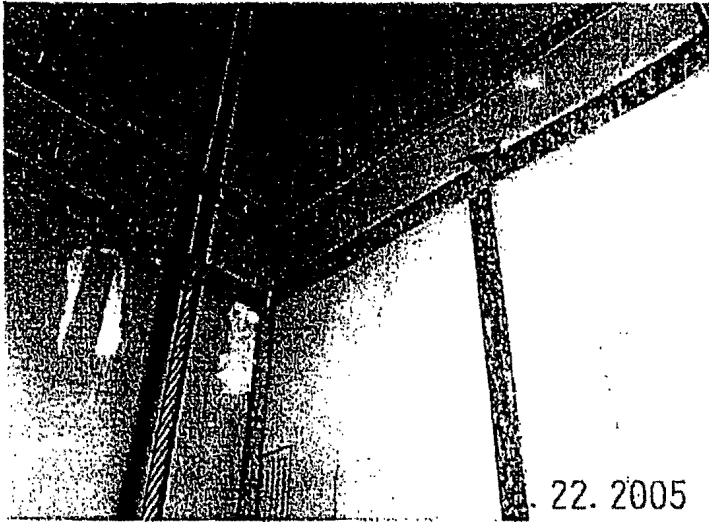

Water stains on elevator gypsum shaft liner panel below location of floor slab.

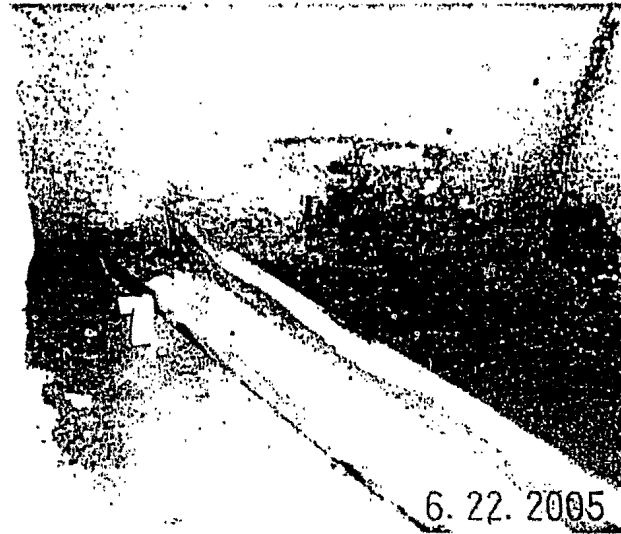

Damp concrete and surface corrosion on unpainted steel embed plates at 10th level indicating presence of moisture.



Surface corrosion on unpainted structural steel at 10th level indicating presence of moisture.



Unprotected cable penetration in floor of microwave balcony.

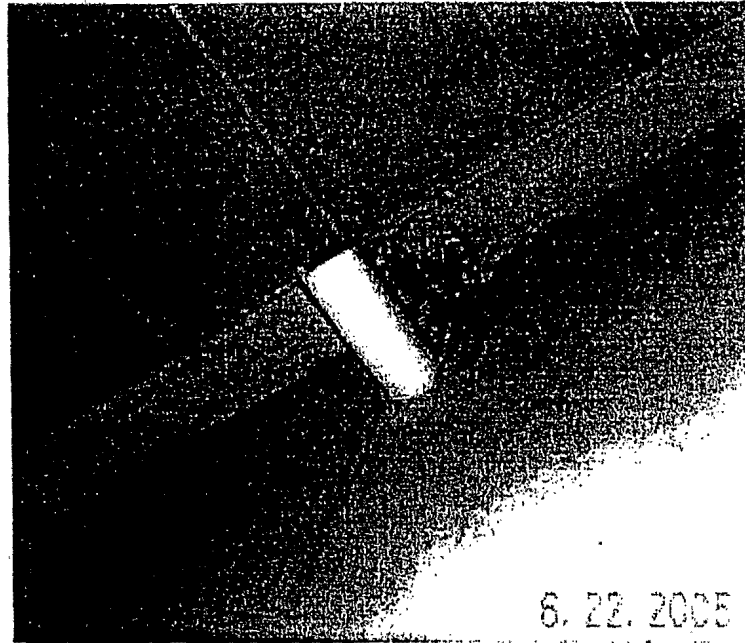
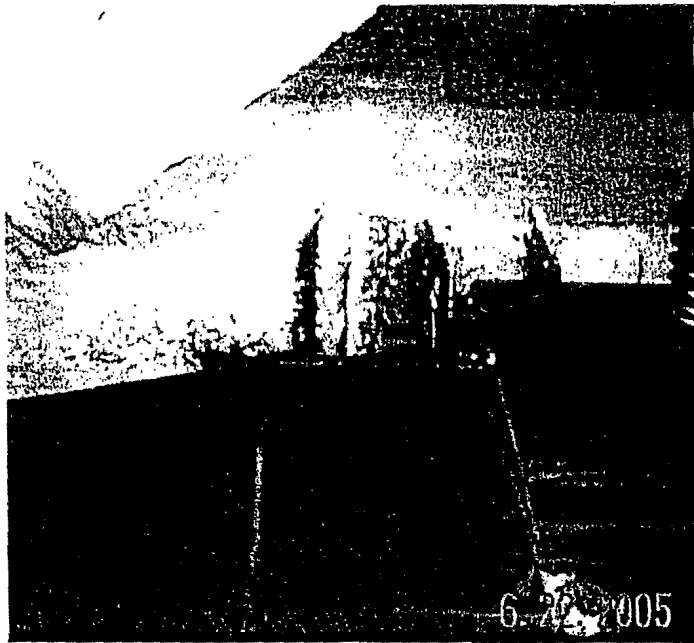

Evidence of past drain leak.

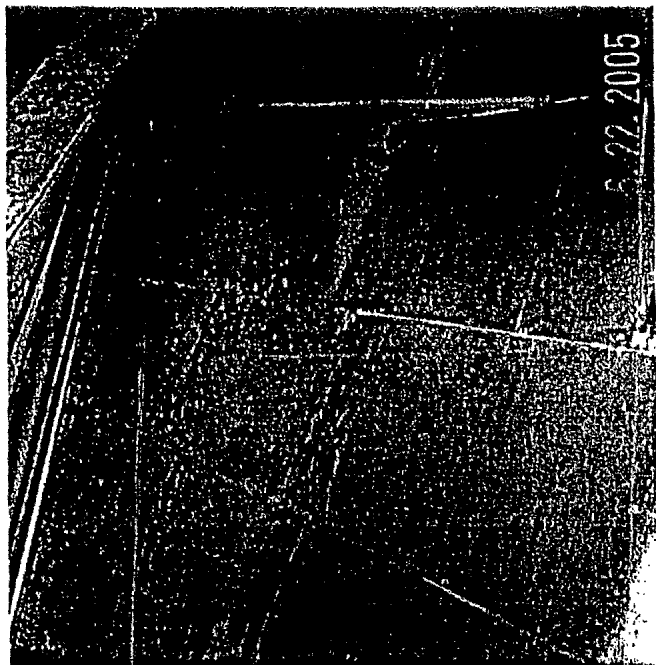

Water stains on inside surface of pre-cast panels below grating at microwave balconies.

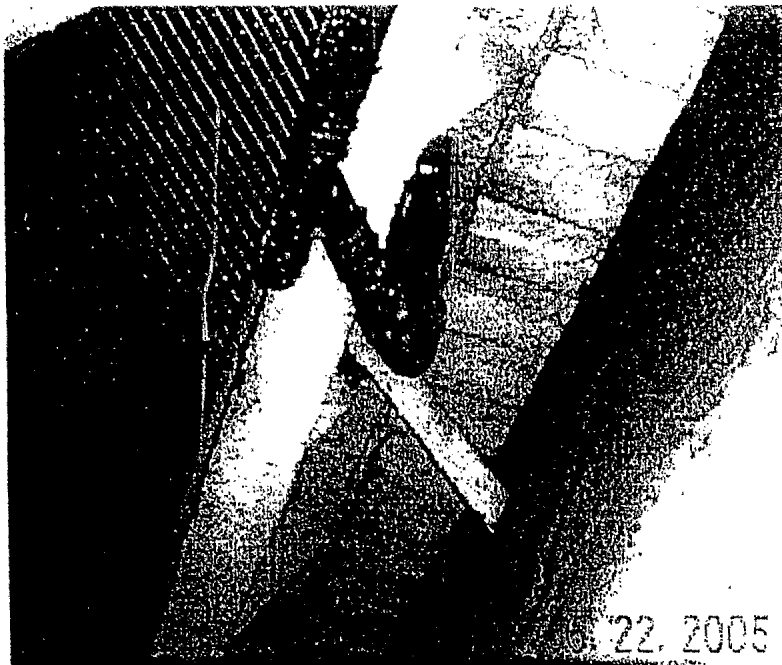

Repaired floor drain from past break and subsequent flooding.



Discarded pipe elbow, indicating repair of a past drainpipe break.

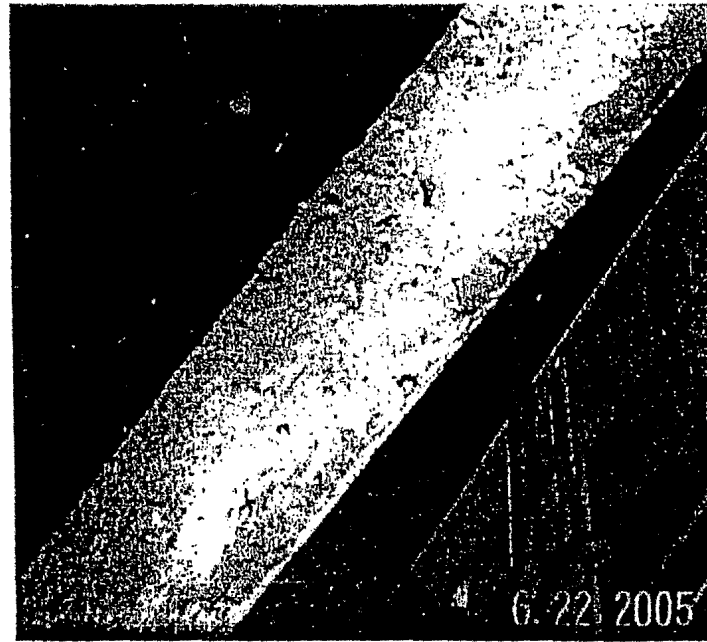

Lightweight fire proofing on structural steel below the microwave balcony. Rainwater from grating above has washed off some of this material, which is blocking the floor drain below.

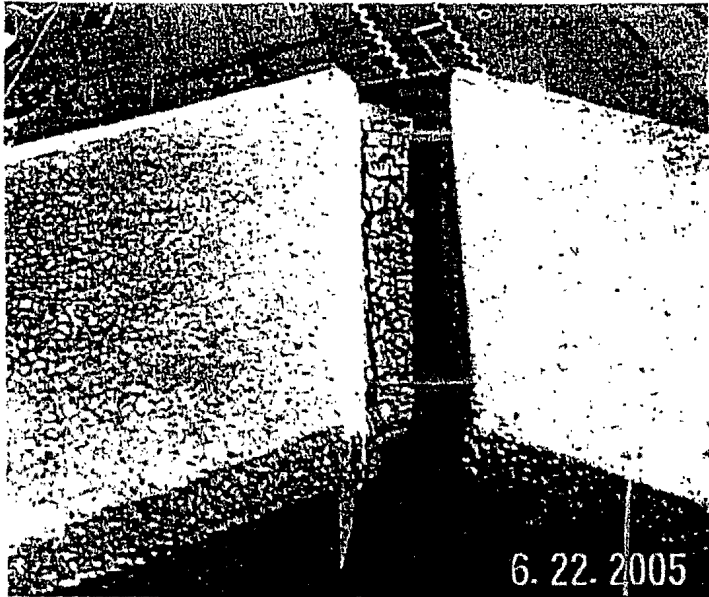

Typical example of failing exterior caulk joints between pre-cast panels.

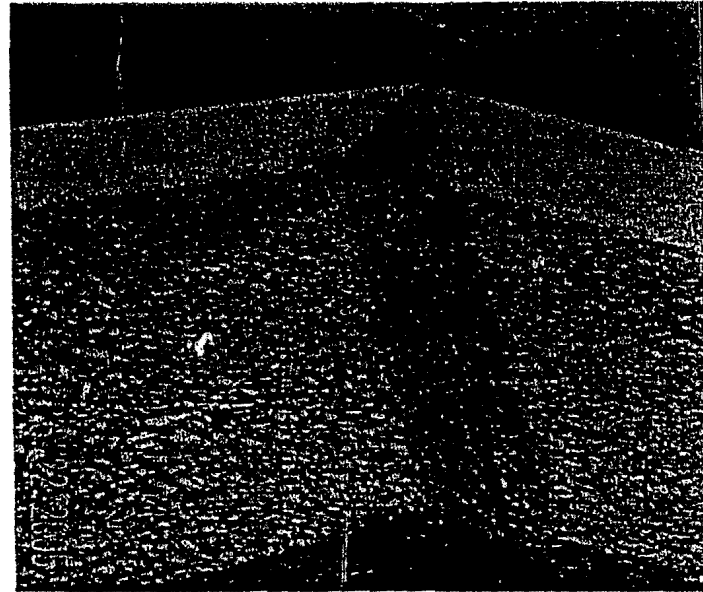

Typical example of failing exterior caulk joints between pre-cast panels.

APPENDIX 2

ROM COST ESTIMATE SCHEDULES

Estimate Worksheet

| | | | |
|---|-----------------------------------|---------|------------------------------|
| CLIENT: Federal Aviation Administration | TASK/SITE NO. FSWS4207 | JOB NO. | DATE SUBMITTED 28-July-05 |
| PROJECT AND CITY ATCT At Detroit Metro Wayne Co. Airport | ACTIVITY: Moisture Assessment | | Moisture Assessment Report |
| Moisture Assessment Detroit, Michigan | ITEM: ARCHITECTURAL/MECHANICAL | | |

| | | | |
|-------------------------------------|---------------------|--------------------|---------------------|
| ESTIMATE VALID TO: December 2005 | ESTIMATED BY: TH | DATE: 30-Aug-05 | SHEET NO. 3 OF 3 |
|-------------------------------------|---------------------|--------------------|---------------------|

| DESCRIPTION OF WORK | QUANTITY | | MATERIAL | | LABOR | | EQUIPMENT | | TOTALS |
|---|-----------|------------|-----------|----------|----------|----------|-----------|----------|---------|
| | NO. UNITS | UNIT MEAS. | PER UNIT | SUBTOTAL | PER UNIT | SUBTOTAL | PER UNIT | SUBTOTAL | |
| ARCHITECTURAL/MECHANICAL | | | | | | | | | |
| DIVISION 02 - Demolition | | | | | | | | | |
| 1. Demo Drywall Partitions | 1,100 | SF | 0.00 | 0 | 4.03 | 4,428 | 0.12 | 133 | 4,560 |
| 1. Demo Doors | 9 | EA | 0.00 | 0 | 40.25 | 362 | 1.21 | 11 | 373 |
| 1. Demo Door Frames | 9 | EA | 0.00 | 0 | 74.75 | 673 | 2.24 | 20 | 693 |
| 2. Cut Drywall 1/4" from Floor/Slab Interface | 30 | LF | 0.00 | 0 | 17.25 | 518 | 0.52 | 16 | 533 |
| 3. Wash/Clean Shaftwall | 6,100 | SF | 0.25 | 1,525 | 1.58 | 9,638 | 0.25 | 1,525 | 12,688 |
| 4. Remove Caulk at Interior and Precast | 1,300 | LF | 0.00 | 0 | 17.25 | 22,425 | 116.00 | 150,800 | 173,225 |
| DIVISION 07 - Thermal/Moisture Protection | | | | | | | | | |
| 2. Fire Sealant | 30 | LF | 5.18 | 155 | 4.60 | 138 | 0.14 | 4 | 297 |
| 4. Caulk Joints | 1,300 | LF | 1.15 | 1,485 | 17.25 | 22,425 | 0.52 | 673 | 24,593 |
| 5. Waterproof Traffic Membrane | 600 | SF | 2.53 | 1,518 | 13.80 | 8,280 | 0.41 | 248 | 10,046 |
| DIVISION 09 - Finishes | | | | | | | | | |
| 2. Vinyl Base | 30 | LF | 1.15 | 35 | 1.15 | 35 | 0.03 | 1 | 70 |
| 3. Paint Shaftwall | 6,100 | SF | 0.29 | 1,754 | 1.15 | 7,015 | 0.03 | 210 | 8,979 |
| DIVISION 15 - Mechanical | | | | | | | | | |
| 1. New Cooling Coil in Vestibule Vent. System | 1 | EA | 5,750.00 | 5,750 | 5,900.00 | 6,900 | 207.00 | 207 | 12,857 |
| 1. Remove SVF-1 & SVF-2 Fan Motors | 2 | EA | 0.00 | 0 | 575.00 | 1,150 | 17.25 | 35 | 1,185 |
| 1. Install New Motors | 2 | EA | 1,725.00 | 3,450 | 575.00 | 1,150 | 17.25 | 35 | 4,635 |
| 1. Chilled Water Piping 1" | 50 | LF | 11.50 | 575 | 11.50 | 575 | 0.35 | 17 | 1,167 |
| 2. Control, Thermostat & Control Valve | 1 | LS | 0.00 | 0 | 2,875.00 | 2,875 | 86.25 | 86 | 2,961 |
| 2. Disconnect Damper Operators | 1 | LS | 0.00 | 0 | 2,300.00 | 2,300 | 69.00 | 69 | 2,369 |
| 2. New Building Automation Computer System | 1 | LS | 11,500.00 | 11,500 | 0.00 | 0 | 0.00 | 0 | 11,500 |
| 2. Operator Training | 4 | EA | 0.00 | 0 | 2,875.00 | 11,500 | 86.25 | 345 | 11,845 |
| 2. Add Control to Software | 1 | LS | 0.00 | 0 | 5,750.00 | 5,750 | 172.50 | 173 | 5,923 |
| 3. Balance Tower HVAC System | 1 | LS | 0.00 | 0 | 9,200.00 | 9,200 | 276.00 | 276 | 9,476 |
| TOTAL ARCHITECTURAL | | | | | | | | | |
| | | | | 27,757 | 117,336 | | 154,883 | | 299,976 |

APPENDIX 3

SITE VISIT ATTENDANCE LIST(S)

- 1. Coordination Meeting Tuesday afternoon, June 21, 2005**
 - 2. Site Survey, Tuesday Night, June 21, 2005**
-

Site Coordination Meeting
June 21, 2005- Afternoon Meeting

Sign-In

| NAME | COMPANY | TITLE |
|-----------------|---------------|---------------------|
| Diane Morse | FAA-AGL-473 | Civil Engineer |
| Ward Stallworth | Jacobs | Architect |
| Andy Szente | Jacobs | Mechanical engineer |
| Dave Bennett | Mr. Handyman | Carpenter |
| Pravin Putel | FAA-AGL-473 | Mechanical engineer |
| Michael Pinto | Wonder Makers | Consultant |
| Vinnie Sugent | NATCA DTW | FACREP |
| John Guth | FAA ATCT | OPS Mgr |
| Mike Prieur | FAA | DTWB |
| Jana Lienemann | Jacobs | HSE |

Elevator Evaluation Meeting
June 21, 2005- Evening Meeting

Sign-In

| NAME | COMPANY | TITLE |
|-----------------|------------------------|---------------------|
| Diane Morse | FAA-AGL-473 | Civil Engineer |
| John Guth | FAA ATCT | OPS Mgr |
| Jana Lienemann | Jacobs | HSE |
| Mike Prieur | FAA | DTWB |
| Vinnie Sugent | NATCA DTW | FACREP |
| Michael Pinto | Wonder Makers | Consultant |
| Dave Bennett | Mr. Handyman | Carpenter |
| Pravin Putel | FAA-AGL-473 | Mechanical engineer |
| Ward Stallworth | Jacobs | Architect |
| Andy Szente | Jacobs | Mechanical engineer |
| Jeff Wesley | Thyssen Krupp Elevator | Elevator Technician |

1

1



Safety Risk Management Plan
Detroit Metro Air Traffic Control Tower (ATCT)
Long Term Building Evaluation

Jacobs Facilities, under contract to the ATO, will be performing an engineering evaluation of the DTW ATCT. The team will be on site the period June 21 – 22, 2005. The scope of their evaluation is to visit all spaces within the ATCT; survey the elevator shaft; and inspect all mechanical systems to identify the source of the moisture in the building and to evaluate any associated structural impacts. To minimize disruptions at the facility, the elevator shaft survey will be completed in a two-hour period between 11PM, June 21 and 1AM on June 22.

This risk assessment is based on a previous assessment where similar risks were assessed during a larger scaled project. (Ref: Moisture Remediation Short Term Project, dated May 10, 2005)

All known risks based on the following "Project Execution Work Plan for DTW" have been assessed in the attached risk management plan (RMP). This is a living document and can be amended as necessary.

1

2

Safety Risk Management Plan Project Execution Work Plan for DTW

1.0 KICK-OFF

The project kick-off consists of the pre-survey telcon with the FAA and the on-site AF coordination meeting as part of the survey activity.

- 1.1 Prior to the site survey, Jacobs and the FAA will hold a telcon to go over the timetable and project execution work plan:
- 1.2 FAA provides all related as-builts and prior related assessments

2.0 SITE SURVEY

2.1 Jacobs's team, as follow:

- Environmental - Jana Lienemann
- Mechanical - Andy Szente
- Architect - Ward Stallworth
- Carpenter – David Bennett

2.2 Time table

Tuesday, June 21, 2005

- Hold on-site AF coordination meeting, 1PM EDT, Tuesday afternoon.
- Conduct preliminary walk-through of areas outside the elevator shaft
- Pre-survey and locate exterior accessibility around the elevator shaft walls that are accessible for intrusive observation "outside" of elevator shaft.
- Return to site at 11PM, accompanied by a carpenter.
- Survey the entire elevator shaft between 11PM and 1AM (Wednesday), identify shaft wall areas of interest for further or intrusive exploration.
- As deemed appropriate cut openings in exterior layer of elevator shaft drywalls in vicinity of identified areas of interest for intrusive observation. All intrusive activities will be performed using dust control techniques including the use of a zip saw or spiral cut saw and hepa vacuum. Use digital camera photography for observation and/or scope photography.
- After observation, repair cuts in elevator and other drywall openings made in the course of this evaluation. All replacement drywall will be of same quality and fire rating as existing.
- As required, heap vac will be used during cutting and cleaning operations. Carpenter may return to the site to complete repairs and paint.

Wednesday, June 22, 2005

- Return to site on morning of June 22, and conduct general survey of all accessible areas observed to have, or where evidence of water leaks, stains, moisture issues were observed or reported.
- Meet with AF Environmental Technicians to evaluate mechanical systems.
- Depart site, conclude survey Wednesday afternoon, June 22, 2005.

3.0 REPORT

Jacobs will submit a report of observations, findings and recommendations for path forward and mitigation for observed issues.

1

3

IN THE MATTER OF AN ARBITRATION

BETWEEN

FEDERAL AVIATION ADMINISTRATION
Detroit, Michigan

AND

NATIONAL AIR TRAFFIC CONTROLLERS
ASSOCIATION, Local DTW/D21

Daniel M. Winograd
Arbitrator

Grievant: Bargaining Unit
Unsafe Conditions (Mold)

Case Nos. (NC) GL-05-072
(NC) GL-05-118
(NC) GL-05-119
(NC) GL-05-943
(NC) GL-05-986

1. The arbitrator was selected by the parties in accordance with the parties' Collective Bargaining Agreement.
2. A hearing was held at the Hilton Garden Inn, Romulus, Michigan, on June 20, 21, and 22, 2007.

Appearances for the Agency were:

Kevin Dunphy, Attorney
Salina Gambon, Labor Relations Specialist
Michael Shawn, Program Manager
Ann Sheehan, EPS
Robert Haefner, ATCS/DTW Tower
Tim Herrin, Witness

Appearances for the Union were:

Jennifer J. Kukac, Attorney
Mark Shapiro, Dir. Labor Relations
Pat Forrey, President
Lewis Bird, Vice President
Vince Sugent, Facility Representative
Jeff Blow, Facility Representative
Harold Pierce, Safety Representative
Michael Pinto, Witness
Kim Eberhart, Witness
Michael McCoy, Witness
Reed Skinner, Witness
Ron Carlson, Witness
Tracy Gillen, Witness
Teresa Bennett, Witness

3. A stenographic transcript of the proceedings was received by the arbitrator on or about July 12, 2007.
4. The post hearing briefs of the parties were received by the arbitrator on or about August 15, 2007.

OPINION AND AWARD OF THE ARBITRATOR

ISSUE

The parties have been unable to agree upon a statement of the issues to be determined by the arbitrator in this matter. The Union states the issues as:

"1. Did the Agency fail to make every reasonable effort to provide and maintain safe and healthful working conditions from September 2004 to present as it relates to the discovery, pre-abatement and abatement of mold in the Detroit Tower and TRACON facilities under the terms of the parties' Collective Bargaining Agreement, Articles 9, Section 1A, Article 53, Article 102, FAA Order 3900.19, Executive Order 12196, Public Law 91-596, the OSHA general duty clause, related OSHA regulations and related FAA policies? If so, what is the remedy?

"2. Are the employees who worked in the Detroit Tower on January 22, 2005, entitled to hazardous duty pay pursuant to the parties' 2003 Collective Bargaining Agreement, Articles 9, Section 1A, Article 81, Article 102 and related FAA policies? If so, what is the remedy?

"3. Did the Agency fail to make every reasonable effort to provide and maintain safe and healthful working conditions as it related to the Detroit Tower union office under the terms of the parties' Collective Bargaining Agreement Articles 9, Section 1A, Article 53, Article 102, FAA Order 3900.19, Executive Order 12196, Public Law 91-596, the OSHA general duty clause, related OSHA regulations and related FAA policies? If so, what is the remedy?"

The Agency states the issues as:

"1. Did the Agency fail to abide by P.L. 91-596 and Executive Order 12196, concerning occupational safety and health, and regulations of the Assistant Secretary of Labor for Occupational Safety and Health, or fail to make every reasonable effort to provide and maintain safe and healthful working conditions from September 2004, to present, as it relates to the discovery, pre-abatement and abatement of mold in the Detroit Tower and TRACON facilities, if not what is the remedy?

"2. Are the employees who worked in the Detroit Tower on January 22, 2005, entitled to hazardous duty pay pursuant to Article 81 of the parties' 2003 Collective Bargaining Agreement? If so, what is the remedy?"

"3. Did the Agency fail to abide by P.L. 91-596 and Executive Order 12196, concerning occupational safety and health, and regulations of the Assistant Secretary of Labor for Occupational Safety and Health, or fail to make every reasonable effort to provide and maintain safe and healthful working conditions as it related to the Detroit Tower union office? If not, what is the remedy?"

The parties' statements of the issues both encompass essentially the same overriding issue, as well as a secondary issue. The arbitrator finds that the overriding issue is:

"Has the Agency violated the applicable provisions of the Collective Bargaining Agreement and applicable law, rules, orders and regulations by failing to make every reasonable effort to provide and maintain safe and healthful working conditions in the Detroit Tower, TRACON and Union offices since its discovery of mold contamination in September, 2004? If so, what is the appropriate remedy?"

The arbitrator further finds that the second issue is:

"Are the employees who worked in the Detroit Tower on January 22, 2005, entitled to hazardous duty pay under Articles 9, 81 and 102 of the Collective Bargaining Agreement, or other applicable law, rules, regulations or orders? If so, what is the appropriate remedy?"

The parties stipulated that the five grievances filed by the Union concerning mold contamination at the Detroit Tower and TRACON facilities are to be consolidated for hearing in a single hearing conducted by the arbitrator. They have stipulated that this matter is properly before the arbitrator for final and binding arbitration, and that there are no issues concerning either the procedural or substantive arbitrability of the dispute. They have

further stipulated that the arbitrator may retain jurisdiction over this matter for purposes of resolving any disputes which may arise concerning implementation of the arbitrator's award.

RELEVANT CONTRACT PROVISIONS

(Jt. Ex. 1)

**ARTICLE 13
UNION PUBLICATIONS AND INFORMATION
AND USE OF AGENCY'S FACILITIES**

Section 5. In facilities where unused suitable space is available in non-work areas, the Union shall be permitted to use such space for the placement of file cabinets or other similar equipment. Such space may be an office if the Agency determines one is available. The Agency shall make a reasonable effort to provide excess desks, chairs, file cabinets or other similar equipment for Union use. . . The Agency reserves the right to withdraw from such space arrangements whenever the space is required.

**ARTICLE 53
OCCUPATIONAL SAFETY AND HEALTH**

Section 1. The Agency shall abide by P.L. 91-596 and Executive Order 12196, concerning occupational safety and health, and regulations of the Assistant Secretary of Labor for Occupational Safety and Health and such other regulations as may be promulgated by appropriate authority.

Section 2. The Agency shall make every reasonable effort to provide and maintain safe and healthful working conditions. Factors to be considered include, but are not limited to, proper heating, air conditioning, ventilation, air quality, lighting and water quality.

Section 9. In the event of construction or remodeling within a facility, the Agency shall insure that proper safeguards are maintained to prevent injury to bargaining unit employees.

Section 13. Indoor air quality concerns identified by the local Occupational Safety and Health Committee, including those involving "sick building syndrome," shall be investigated using advisory standards of the American Society for Heating and Refrigerating and Air-conditioning Engineers, and EPA and OSHA guidelines. All test results shall be provided to the local union as soon as they are available.

**ARTICLE 81
HAZARDOUS DUTY PAY**

Section 1. Hazardous duty pay differential(s) shall be paid by the Agency in accordance with 5 CFR Part 550, Subpart 1.

**ARTICLE 102
EFFECT OF AGREEMENT**

Section 1. Any provision of this Agreement shall be determined a valid exception to, and shall supersede any existing or future Agency rules, regulations, directives, orders, policies and/or practices which conflict with the Agreement.

OTHER RELEVANT MATERIALS

Public Law 91-596 (Occupational Safety and Health Act)
(Jt. Ex. 20)

Section 5

(a) Each employer:

(1) shall furnish to each of his employees employment and a place of employment which are free from recognized hazards that are causing or are likely to cause death or serious physical harm to his employees

(2) shall comply with occupational safety and health standards promulgated under this Act.

FAA Order 3900.19B
(FAA Occupational Safety and Health Program)
(Jt. Ex. 17)

Chapter 1 - General

8. Policy. This order sets the policy for the framework of the overall agency OSH program.

A. General. The FAA is committed to providing for the occupational safety and health of employees. . .

Chapter 33 - Toxic and Hazardous Substances Exposure
Control Program

3300. GENERAL. This chapter covers the establishment of a Federal Aviation Administration (FAA) program to control employee occupational exposures to toxic and hazardous substances that may occur through inhalation, by absorption through the skin, by ingestion, or through surface contact with the skin. . .

3304. PROGRAM REQUIREMENTS

a. General. The following process is to be utilized for establishing a program to evaluate employees exposure to toxic and hazardous substances in FAA workplaces.

(1) Evaluate the workplace to identify the presence or potential for toxic and hazardous substances. If the presence of a toxic or hazardous substance(s) is identified, appropriate testing should be conducted by technically qualified safety personnel. . .

(2) If the exposure determination reveals that acceptable levels are exceeded, a hazard control program should be established to remove or reduce the hazard, or substitute the substance with a less hazardous material. . .

e. Exposure Control

(1) To achieve compliance with exposure limits specified in paragraph 3304b, engineering controls must be evaluated and implemented whenever feasible. . .

(2) When engineering controls are not feasible, nor sufficient to reduce exposure to within acceptable limits, administrative controls (such as, rotation of workers, employee training, etc.) shall be evaluated and implemented.

FAA Order 3550.10
(Pay Administration)
(Jt. Ex. 18)

Section 2. Pay for General Schedule Employees for Irregular or Intermittent Duty Involving Physical Hardship or Hazard.

312. Definitions

a. Duty Involving Physical Hardship means a duty which may not in itself be hazardous but which causes extreme physical discomfort or distress and which is not adequately alleviated by protective or mechanical devices.

Executive Order 12196 - Occupational Safety and Health
Program for Federal Employees.
(Jt. Ex. 19)

1.2 Heads of Agencies.

1-201: The head of each agency shall . . . furnish to employees places and conditions that are free from recognized hazards that are causing or are likely to cause death or serious physical harm. . .

(e) Assure prompt abatement of unsafe or unhealthy working conditions. Whenever an Agency cannot promptly abate such conditions, it shall develop an abatement plan setting forth a timetable for abatement. . .

FACTS

By agreement of the parties, five grievances were consolidated for hearing by the arbitrator¹. All of the grievances arose in the Tower and TRACON facility at Detroit-Metro Airport, and all concern the discovery of mold contamination within the facility and the Agency's efforts to abate the contamination.

Grievance No. GL-05-072 (Jt. Ex. 2) was filed by the Union on behalf of all bargaining unit members on December 20, 2004. It asserts that between September 28, 2004 and December 11, 2004 "black mold"² was found on the 4th and 9th floors of the facility, that the mold infestation "may have caused a 'sick building syndrome,'" and that the Agency has not made "every

¹The hearing was conducted over a period of two days. In addition, the arbitrator has received approximately 4000 pages of exhibits and 500 pages of transcript. The parties stipulated to the admissibility of both the Union's exhibits and the Agency's exhibits, with the further agreement that either party could rely upon those exhibits without providing foundational testimony. Thus, a substantial portion of the evidence relied upon by the parties in their briefs was not the subject of testimony at the arbitration hearing.

²The specific molds involved are acremonium, penicillium, stachybotrys and ulocladium. Stachybotrys is considered a "toxic" or "black" mold.

reasonable effort to provide and maintain safe and healthful working conditions" in the facility. The grievance asks that the Agency "comply immediately" with all relevant laws, rules regulations and orders concerning mold in government facilities, that it restore 120 hours of sick leave to all bargaining unit members at the facility and reimburse employees for medical expenses incurred in connection with the mold problem. The Agency's response dated January 7, 2005 indicates that necessary remediation efforts have been made. Therefore, the grievance is denied. (Jt. Ex. 3)

Grievance No. GL-05-118(Jt. Ex. 4) was filed on February 9, 2005. It sets forth a detailed history of events beginning with the discovery of mold in the facility on September 28, 2004, including an incident on January 22, 2005. On that date, a contractor hired by the Agency was performing abatement work in the elevator shaft of the facility, using a chemical which caused employees to suffer a variety of symptoms and resulted in the evacuation of the facility. The grievance requests that three Agency employees be removed "from their current positions and banish them from any decisions or work that involves the safety of any Federal Building or personnel." It also requests continuous testing and monitoring of air quality within the facility, sealing of contaminated areas and abatement of any molds that are discovered. The Agency's response dated February 24, 2005, agrees

to the Union's demands that air quality be monitored and that monthly inspections be conducted, but it denies the grievance in all other respects.

Grievance No. GL-05-119 was also filed on February 9, 2005 (Jt. Ex. 6). It seeks the same relief as requested in the previous two grievances. Additionally, it requests that all members of the bargaining unit receive hazardous duty pay for their hours of work from September 28, 2004 until the mold is abated. That grievance was denied on February 24, 2005. (Jt. Ex. 7).

Grievance No. GL-05-943 (Jt. Ex. 9) was filed on June 14, 2005. It asserts that the Agency's efforts to remediate the mold problem in May, 2005 was negligently and inadequately performed. It requests that the Agency take 13 remedial actions, including cleaning the Union offices, and performing the work described in the other grievances that had been filed as of June, 2005.

Grievance No. GL-05-986 (Jt. Ex. 12) was filed on July 11, 2005. It outlines the discussions held between the Agency and the Union since September, 2004. It asserts that the mold problem has not been abated, and requests 18 remedial measures, including the removal of a fourth Agency employee from the remediation project, the sealing and cleansing of affected areas and the placement of air scrubbers in the facility. It also requests that the Agency remove and bar various Agency personnel "from any decisions or work that involves the safety of any Federal

Building," that it reimburse employees for medical expenses, provide free medical checkups and care to all employees for a period of five years, restore to the bargaining unit all sick leave taken since September, 2004, and pay them hazardous duty pay retroactively to September, 2004. The grievance was denied on July 27, 2005. (Jt. Ex. 13).

All of the grievances were appealed to the Third Step grievance process and were denied at that stage. Thereafter, the Union invoked arbitration. (Jt. Ex. 8,10,11,14, 15, 16).

The air traffic control facility is an eleven story building. The top floor, or "cab" is a glass enclosed structure from which air traffic controllers monitor and control the movement of aircraft into and out of the airport and while they are on the ground. The TRACON is a radar room located on a lower floor of the building from which controllers monitor and control aircraft outside the range of the cab radar. The rest of the building consists of offices, equipment rooms, training rooms, break rooms, storage rooms and an office set aside for the Union to conduct its business. All floors are served by elevators which run through an elevator shaft in the center core of the building. The shaft is a metal framed structure. Its interior and exterior walls are covered with gypsum board or "sheet rock". The interior lining of the elevator shaft is fire retardant sheet rock. The parties agree that gypsum board is generally considered to be a porous material.

Chronology of Events

The dispute giving rise to these grievances has its origin in a routine safety inspection conducted by the Agency and representatives of the Union on September 28, 2004. On that date, Musa Abuzir, the primary inspector reported that "during our annual OSH Inspection at Tower we found a SUSPECTED Black Mold at the Ninth Level, Room 928 on the Dry Wall." (Ag. Ex. 1) He reported that the room would be posted with a "Do Not Enter" sign pending further investigation. On the following day, Abuzir reported that suspected mold areas had been found in Room 927 and Room 428. He directed that the affected areas be posted, and he reported that samples had been taken by MoldQuest International, Inc., for further analysis. On October 13, 2004, Abuzir reported that the lab tests had confirmed the presence of various molds, including "black" mold spores. He recommended that "the Drywalls at both floors (Ninth and the Forth [sic] Levels be removed by a licensed Mold Abatement Contractor," and that access to those floors be restricted pending abatement of the mold³.

The Agency retained MoldQuest International, to investigate the contamination and propose remedial actions. MoldQuest's report (Ag. Ex. 2), dated October 10, 2004 confirms the presence of "significant amplification of" various molds, including

³The contaminated rooms were used as locked storage rooms. Neither had HVAC equipment or ductwork in it. (Ag. Ex. 6)

black mold in Room 928. It notes that exposure to black mold and its related toxins may result in "allergic reactions, toxic symptoms and/or infection in susceptible individuals."⁴ The report concludes that the "affected wall materials were highly saturated for an extended period of time." Therefore, the report recommends that adjacent areas also be inspected for mold and water damage, and that all affected materials should be removed under "containment (negative air) conditions."

In response to the MoldQuest report, the Agency adopted a "Statement of Work" seeking bids for the mold remediation work. (Ag. Ex. 3) The bid solicitation called for the work to begin approximately December 10, 2004. It called for bidders to agree to remove all mold affected areas, including a double layer of gypsum board, as well as any insulation or other material contaminated by mold spores. All work was to be performed in accordance with applicable rules and regulations and was to be overseen by Abuzir as the Agency's representative. Additionally, the solicitation called for all work to be supervised by an industrial hygienist certified by the American Board of Industrial Hygienists. Representatives of the Union were to be briefed by the contractor concerning the work to be performed, and all work was to be

⁴The main body of the report indicates that the toxic effects of molds may result from short term exposure to high levels of mold spores, or from long term exposure to low levels of the spores. It further indicates that in order for those effects to occur, the spores must be inhaled, ingested or subjected to physical contact by the affected individual.

performed under isolation procedures, including the use of air scrubbers, negative air pressure, HEPA filters and plastic sheeting. The bid was awarded to MIS Environmental Services, Inc. (Ag. Ex. 5).

MIS began performing its work on January 19, 2005. However in the course of removing contaminated drywall, it discovered additional contamination on the walls adjoining the elevator shaft (Ag. Ex. 6). During additional investigations on January 21, 2005, the Certified Industrial Hygienist discovered that the interior walls of the elevator shaft were contaminated. She recommended that the interior of the elevator shaft be washed down and treated with a biocide to kill the mold. Therefore the Agency hired Catastrophe Cleaning and Restoration Services ("Coach's") to decontaminate the elevator shaft (Ag. Ex. 9).

Coach's began its work at approximately 10:30 a.m. on January 22, 2005. According to the Agency's records (see, Ag. Ex. 6) Coach's presented the Agency with Material Data Safety Sheets (MSDS) for the chemical, MIRGO-SR, which it was using to decontaminate the shaft. The MIRGO-SR contained alcohol and glutaraldehyde, both of which were considered low risk chemicals by the Environmental Protection Agency. (Ag. Ex. 7) No Agency representative observed Coach's employees when they mixed the chemicals. The scrub down and spraying of elevator shaft walls was completed at approximately 12:50 p.m. on January 22, 2005.

At approximately 12:55, management received a call from the tower cab supervisor indicating that some of the employees in the cab were complaining about the smell of the decontamination chemicals and were feeling dizzy and light headed. The supervisor indicated that he had sent some employees home, but by 1:30 p.m. enough employees were complaining about the effects of the chemical⁵ that the decision was made to close the tower and transfer its operations to the old tower located at the airport. The tower was evacuated within two hours. In the meantime, Coach's installed an air scrubber in the tower and requested that the Fire Department respond to the scene. The Fire Department personnel were unable to test for chemicals in the air, but found no evidence of carbon dioxide or explosive gasses. After additional air scrubbers were installed and the tower was allowed to be aired out, operations resumed in the tower at approximately 7:00 p.m. (Ag. Ex. 8) The Agency reported that eight employees had sought medical care as a result of their exposure to the biocide. (Ag. Ex. 12)

Safety Program Manager Charles Bragdon investigated the incident on January 24, 2005. He reported that according to the website for MIGRO-SR, there are two versions of the MSDS for the product. The most recent MSDS does not indicate that the product contains glutaraldehyde. However, Bragdon indicated, even if the

⁵Not all employees on duty were affected by the chemical emissions. In fact, the four individuals who were working with the chemicals did not use protective devices and did not experience any ill effects from the chemicals.

older MSDS is used. The concentrations of toxic chemicals in the MIGRO-SR are well below recognized safety standards for the chemicals. Bragdon notes that the "odor thresholds for both of these chemicals are much lower than the exposure limits. This means that just because you can smell them does not mean that there is a significant exposure." (Ag. Ex. 11

In a further effort to assure that the black mold had been removed from the tower, the Agency employed Tillotson Environmental Occupational Consulting (TEOC) to conduct further tests within the facility. TEOC examined the facility on January 22, 23 and 24, 2005. TEOC reported that in its examination of January 22, it found a low level of Basidiospores in the 4th floor equipment room, indicating that "contamination of surfaces apparently did not occur during the abatement and initial removal of the contaminated drywall was done correctly." (Ag. Ex. 20 However, some areas of contamination continued to exist. Therefore, TEOC recommended that a remediation specialist recommended by the Union's expert, Michael Pinto, be hired to complete the removal of drywall, drywall dust and molds.

TEOC's report on its January 24, 2005 inspection; found low levels of black mold contamination in three locations that had been isolated during the previous inspection. TEOC concluded that the contamination level "is not a problem with air quality", but it recommended continued use of air scrubbers with HEPA filters on the

fourth and ninth floors. TEOC recommended that in the long term, the Agency should "eliminate any leaks/moisture and perceived/known mold contamination." (Ag. Ex. 21)

TEOC performed its final monitoring on January 25, 2005. It issued a lengthy report (Ag. Ex. 22). With regard to the possible air contamination caused by Champ's use of MILGO-SR, TEOC concluded that the symptoms described by employees "did not correlate with the potential symptoms of overexposure to MILGO-SR biocide." TEOC further notes that the four individuals directly involved in applying the MILGO-SR did not suffer ill effects. Therefore, TEOC concludes, "The fragrance/lemon scent [in the MILGO-SR] may have caused a psychological/somatic effect in those personnel affected." Tape samples taken in 6 areas of the facility all resulted in no black mold being discovered, although other mold spores were found. Therefore, TEOC concluded that the MILGO-SR treatment had not caused illness among employees, and had been successful in removing black mold from the facility. TEOC recommended locating and repairing the source of water in the elevator shaft and elsewhere, and the removal of contaminated drywall on the fourth and ninth floors, as well as in the elevator shaft. It also recommended modification of the HVAC system to eliminate water condensation within the walls and elevator shaft.

At the same time TEOC was conducting its inspection, both OSHA and the Agency's Technical Operations unit were also conducting independent investigations. (See, Ag. Ex. 12) A sample of the MILGO-SR solution used for cleaning the elevator shaft was also submitted for chemical analysis to Chemir Analytical Services (Ag. Ex. 23) That analysis found small concentrations of isopropyl alcohol and no glutaraldehyde in the sample. (Ag. Ex. 24). The OSHA inspector concluded that although the Agency failed to provide proper training for the use of the MILGO-SR and did not adequately review the MSDS for the actual product used, the material that was used was less toxic than the product described on the MSDS that was provided by Coach's. Therefore, "it was highly unlikely that the employees could be over exposed" to the biocide. (Ag. Ex. 25).

By March 7, 2005, the Technical Operations staff developed a plan for decontaminating the facility. In a power point presentation (Ag. Ex. 28) presented at a meeting of Agency representatives on March 16, (Ag. Ex. 29) the Technical Operations staff proposed a two track plan for removing and preventing mold contamination. Noting that black mold had been discovered in unused storage areas on the 4th and 9th floors, and that various species of mold had been found in the elevator shaft, the Technical Operations staff proposed that the Agency engage in a process of identifying and correcting the source of moisture in the facility while continuing to abate the existing contamination. In the short

term, the staff proposed that efforts be made to identify and fix all leaks found in the building, that thermal barriers be placed in appropriate locations and that the unventilated areas of the building be provided with a method for moving air, such as fans and dehumidifiers. The staff indicated its belief that accumulations of water in the elevator shaft were being caused by condensation when warm moist air and colder dry air mixed in the elevator shaft.⁶ Thus, it proposed as a long term plan that a mechanical engineer be retained to make recommendations for improving the HVAC system or for providing appropriate air movement to prevent condensation from occurring inside the elevator shaft. In order to remediate the existing contamination, the staff proposed continuous air monitoring and tape testing of the affected areas, removal of contaminated drywall and sealing of other drywall. It noted that the primary constraints preventing immediate achievement of the plan were budgetary, and the need to maintain operational priorities during the remediation process. (Ag. Ex. 28, 29).

Having approved Technical Operations' remediation plan, Agency representatives met frequently throughout March and April, 2005 to implement the plan, deal with unanticipated problems and

⁶The process by which the condensation occurs, the staff speculated is that the elevator shaft is vented at the top and bottom. During the summer months, the movement of the elevator cab in the shaft acts as a piston, drawing warm, moist air into the shaft from outside, where it meets the dry air-conditioned air in the shaft. The process is reversed in the winter, when cold, dry air is drawn into the shaft by the movement of the elevator cab and meets the heated moist air from inside the building. The elevator shaft has no active HVAC or air movement system. It relies solely upon the piston action of the elevator cab to draw air into and push air out of the shaft.

monitor the progress of the plan. Teleconference meetings were held On March 17, March 18, March 23, March 24, March 28, March 30, April 4, April 5, April 6, April 8, April 11, April 14, April 19, April 27, and April 28, 2005 (Ag. Ex. 31, 34, 36, 39, 41, 45-47, 50, 51, 53-58) Work on the project was projected to begin approximately May 16, 2005, after the Agency had solicited and obtained sufficient proposals from contractors seeking to perform the work.

During the course of the discussions, the Agency received reports from two Certified Industrial Hygienists (Ag. Ex. 32, 37) confirming that low levels of mold were found in air samples and tape tests of the facility. At approximately the same time, OSHA issued a "Notice of Unsafe or Unhealthful Working Conditions (Ag. Ex. 43) informing the Agency that it had violated OSHA regulations by failing to have correct MSDS sheets for the MILGO-SR used in the January abatement process and that it had failed to provide adequate training to the employees who used that chemical. The notice did not indicate that the presence of mold in the facility created an unsafe or unhealthful working condition.

By April 19, 2005, the Agency had completed its specifications for the short term abatement and remediation project. (Ag. Ex. 71) Its representatives met with representatives of the Union on May 2, 2005. (Ag. Ex. 57) The remediation project was described at some length and the participants at the meeting

were provided with a written risk assessment for each aspect of the project. Participants were informed that appropriate isolation procedures, including enclosing the work areas in plastic, using air scrubbers and requiring that all workers wear protective clothing would be required. The contract for MIS Environmental to perform the remediation work was issued on May 13, 2005. (Ag. Ex. 61) Additionally, the Agency contracted for an independent Certified Industrial Hygienist to supervise the work. (Ag. Ex. 60)

Between May 16 and May 25, 2005, Technical Operations performed the short term mitigation project. (Ag. Ex. 62, 63, 65, 66) The work was performed under the supervision of a Certified Industrial Hygienist and, according to the progress reports, was performed in accordance with the specifications of the plan approved by management and Technical Operations. The progress reports indicate that appropriate methods were employed to minimize infiltration of mold into uncontaminated areas, and that all personnel used protective clothing. (See, e.g. Ag. Ex. 62, 65) Contaminated drywall and insulation were removed from the third, fourth and ninth floors and air samples were taken for analysis. No black mold was found in the samples drawn from the third and fourth floors, but the black mold was found in the samples from the ninth floor. (Ag. Ex. 67) Other molds found in the building were in similar concentrations to the outside air. Therefore, the Agency directed that the ninth floor be recleaned. (Ag. Ex. 67)

On May 23, May 25 and May 26, 2005, additional air samples were taken on the ninth floor, in the elevator shaft and in the Cab. (Ag. Ex. 68, 69, 70) The results of the air sampling were reported to the Agency by Safe Technology, Inc. On June 13. Safe Technology concluded that "on the days of testing, the average indoor total count was about 24 times lower than the average outdoor total count." (Ag. Ex. 73; see, also, Ag. Ex. 77)

In preparation for the remediation and prevention plan, the Agency retained Jacobs Engineering to conduct an evaluation of the moisture problems experienced in the facility. Jacobs' report (Ag. Ex. 78) notes that evidence of mold contamination and water staining was found in the elevator shaft. Jacobs recommended that the interior walls of the elevator shaft be washed with a bleach solution in order to remove all existing mold. It further recommended that the Agency conduct regular, periodic inspections throughout the building to determine if mold growth was returning.

In order to reduce moisture buildup, Jacobs recommends, the HVAC system should be revised, the exterior walls and foundation should be water sealed, and a new cooling coil should be installed in the outside air intake. Jacobs estimates the cost of the entire project will be approximately \$490,000 (Ag. Ex. 78). The Jacobs report and its recommendations were approved by the Mold Remediation Project Team on September 12, 2005. (Ag. Ex. 79)

Monthly inspections of the facility began in October 2005. During the November 12, 2005, inspection, a water leak was discovered and possible mold growth was identified. (See, Ag. Ex. 80-83). The water leak was fixed and all cleanup activities were conducted on November 12 and 13. On December 12, the Agency adopted a work plan to remove the contamination on the third floor. (Ag. Ex. 84) The contract to remove the contamination was granted to MIS on January 6, 2006. (Ag. Ex. 87) That contract was completed on January 26, 2006. (Ag. Ex. 88)

Throughout the period from October, 2005 through June, 2006, the Agency conducted visual inspections of the facility. A Union representative was present during each of those inspections. (Ag. Ex. 80, 82, 86, 89, 91, 92, 94, 97) Additionally, at the request of the Agency, the Federal Occupational Health ("FOH") component of the U.S. Public Health Service conducted an examination of the facility on February 1, 2006 and the Office of the Inspector General of the U.S. Department of Transportation visited the facility on February 13-16, 2006. (Ag. Ex. 96, 98) A private entity, DMJMH+N was hired by the Agency to conduct a review of the building exterior "envelope" and HVAC system on February 27-28, 2006 (AG. Ex. 93) and OSHA inspected the facility on March 21, 2006. (Ag. Ex. 75)

DMJMH+N presented its findings in a report issued on April 24, 2006 (Ag. Ex. 93) The report concludes that there are numerous locations on the exterior of the building which may allow water to leak into the building, both at its foundation level and at higher levels. The exterior walls on the first nine floors of the building were not insulated during the original construction of the building, thereby creating an enhanced potential for water leakage or condensation. The report recommends extensive efforts to seal and waterproof the exterior walls and footings of the building. It further recommends that insulation be installed on all exterior walls on all floors and that some walls or doors be removed in order to facilitate air flow throughout the structure. Dehumidifiers and pumps to remove condensed water are suggested.

The FOH report was released on May 9, 2006. (Ag. Ex. 96) FOH concurred in many respects with DMJMH+N. Thus, FOH found that various locations on the exterior of the building needed sealing and waterproofing. After summarizing its testing technique, FOH found:

"All of the measurements taken for F° [Temperature] RH [Relative Humidity] CO² and CO were all well within acceptable guidelines for Indoor Air Quality as established by the American Society of Heating, Refrigerating and Air-conditioning Engineers. . . Visual observations of the areas where past mold abatement had taken place along with review of the documents provided by FAA and interviews with facility staff found that all appropriate methods and measures were followed to ensure the health and safety of the federal employees in the facility. . . During the various abatement projects approximately 2' of water damaged and/or mold contaminated wallboard was removed above the floor decking.

From our evaluation it was found that when new wallboard was installed in the abated areas, it was done so in a manner that has the wall board in direct contact with the floor decking. . . This direct contact allows for a 'wicking' of moisture between the wallboard and the floor . . . Typical installation allows a 1/2" to 3/4" gap between the bottom of the wallboard and the floor. . . All of the measurements taken indicated that the current moisture content/levels within the wallboard materials in the facility were well below alarm levels. . .

The observation of the elevator shaft was conducted. . . The shaft wall surface is covered with unpainted 'fire rated' gypsum wallboard. Located at the floor levels within the shaft are several areas of visible moisture staining and water trailing. . . with visible signs of dried mold growth. . . This dry or dormant visible fungal material within the shaft is what would be considered minimal in size in any one area. . . However, there are no current signs of any ongoing water infiltration or leaking. . . Moisture readings were conducted on numerous areas of the fire rated wallboard in the elevator shaft. Again these reading[s] indicated moisture levels well below the MoistureCheck alarm level. . . indicating essentially dry wallboard. . . It is the opinion of FOH that these areas of old mold growth are not currently viable or 'growing'. . .

It is further concluded . . . that the remedial activities to abate the water damaged building material and fungal issues at the facility were conducted properly and within 'Best Practice' of the FAA and contract industrial hygiene professional[s] involved in these efforts. . . It is the opinion of FOH that . . . industry standard guidelines were followed during all remediation activities. . . In review of all data provided, these abatement activities were successful. . . It is our opinion that . . . the airborne fungal concentrations inside the facility would be significantly less than those found outside the structure and that the biodiversity of the types of fungi present would be similar or consistent. . .

In summary, the abatement activities conducted at this facility were performed properly and in a safe manner to ensure the health and safety of the federal employees."

On May 8, 2006, a day before the FOH report was received, the Agency finalized a contract with MIS to perform additional remediation work, including cleaning of drywall inside the elevator

shaft. That work was performed between May 17 and May 26. (Ag. Ex. 95). A Certified Industrial Hygienist observed the work as it progressed, and noted no violations of the protocols required under MIS's contract. (Ag. Ex. 109)⁷

OSHA submitted its report on its investigation of the facility on June 19, 2006. (Ag. Ex. 75) The report notes that no mold samples were taken because no visible mold contamination was discovered. It recommended, however, that the Agency eliminate all sources of water intrusion into the facility and that it make improvements in the HVAC system to avoid the possibility that water condensation would provide a source of moisture needed for mold growth.

Likewise, the report of the Office of the Inspector General of the Department of Transportation, issued on July 11, 2006 (Ag. Ex. 98) noted that mold contamination had been effectively eliminated, but that "until the moisture source has been controlled, mold will continue to be an ongoing problem." It noted that the Agency had developed a plan for sealing and caulking the exterior of the facility, replacement of damaged wallboard and improving the HVAC system to "manage humidity." "Completing those

⁷Ag. Ex. 109 was not submitted to the arbitrator at the time of the arbitration hearing, but was submitted with an Agency motion to supplement the record after the conclusion of the hearing. The Union objected to the supplementation of the record. The arbitrator is allowing the record to be supplemented with the exhibit, as the exhibit merely clarifies the sequence of events, but does not include substantive information that might affect the outcome of the case.

projects,"the report noted "is essential to fully remediate mold at the Facility." Of the 146 employees in the facility, the report indicated, 6 had reported health problems which they attributed to mold contamination. The Department of Labor found that 3 of the 6 Workers Compensation claims had been allowed, one had been denied and two were still pending.

The Department of Health and Human Services, National Institute for Occupational Safety and Health (NIOSH) issued its report of its investigation of the facility on July 24, 2006 (Ag. Ex. 99) NIOSH conducted its investigation as a result of complaints it received from members of the bargaining unit in September and October, 2005. NIOSH reviewed information provided by the Union, as well as the information provided by the Agency and various outside contractors who had worked on the remediation project. The NIOSH report indicates:

"When considered collectively, the various reports and documents provided to NIOSH describe a situation whereby leaks in the building envelope had allowed water to enter the ATCT, wick into drywall, and create a suitable substrate for mold growth. . . This situation has existed since sometime in 2004 (possibly earlier), and can be expected to continue or recur until all leaks have been repaired, HVAC deficiencies corrected, and all mold sources located and successfully remediated. Until this remediation takes place, the employees who experience upper airway symptoms when exposed to mold may continue to experience them.

"Although surface sampling confirmed the presence of mold in certain interior locations. . . we did not find bioaerosol sampling results to be helpful in assessing the extent to which mold may have contributed to health problems among employees. In most cases, bioaerosol sampling is not useful as an environmental evaluation method, as few criteria are

available to assist in the interpretation of the data. Without exposure guidelines for mold in air, it is not possible to distinguish between 'safe' and 'unsafe' levels of exposure. . . and the mere presence of bioaerosols in samples does not prove a causal relationship with complaints. . . A more cost-effective approach is to visually locate bioaerosol sources (microbial contamination) and eliminate the sources following remediation guidelines developed by organizations such as the U.S. Environmental Protection Agency. . .

A review of the submitted symptoms profile [for employees] revealed that prior to January 22, 2005, some employees had low-level non-specific symptoms such as fatigue and headaches. On January 22, 2005, there was an outbreak of upper respiratory tract irritation symptoms. . . Since then there have been reports of current and ongoing symptoms that start a few hours into the work shift and diminish when away from work. Additionally, reports of new-onset asthma and Chlamydiae pneumoniae pneumonia were deemed related to employment in the ATCT. The NIOSH physician could not substantiate such diagnoses based on the medical records provided.

The Institute of Medicine. . . Has found that some upper respiratory tract symptoms such as those reported by FAA employees. . . are associated with damp indoor environments and the presence of mold or other agents in damp indoor environments. . .

The medical records provided to us did not substantiate the diagnosis of C. pneumoniae pneumonia among some FAA employees. . . . It should be noted that C. Pneumoniae is a bacterium, not a fungus (mold).

Regarding the other reported symptoms, the IOM concluded that the evidence of an association between damp indoor environments or exposure to moldy environments and [various symptoms] is either inadequate or insufficient. It should be noted that the absence of sufficient evidence of an association is not synonymous with lack of an association. . . Therefore, the conclusion that mold is not a threat to the health of ATCT employees, as stated in an FAA letter dated December 16, 2006, is not substantiated by scientific evidence. It is imperative to provide employees a work environment free from mold and environmental factors that cause mold growth."

Having received the various evaluations discussed above, the Agency adopted a "Risk Management Plan" dated July 26, 2006. (Ag. Ex. 100) The plan calls for the Agency to remove and replace all caulk and "backer rod" materials in the facility, repairing and washing the pre-cast concrete sections, priming and sealing the building, installing new roof membrane and taking other actions to clean and seal roofs and walkways. It also calls for sealing various vents and adding ventilation equipment to prevent the condensation of water in the elevator shaft. Throughout the project, the plan indicates, air quality is to be monitored and an alternate facility is to be used when noxious or toxic chemicals are being applied⁹. The caulking and sealing work was completed on approximately November 9, 2006 (Ag. Ex. 107). On February 13, 2007, the Agency Joint Acceptance Board recommended acceptance of the HVAC work, including the cleaning of all ducts in air handling units, the installation of heaters on levels 3 through 10 of the elevator shaft and removing and replacing two other air handling units. (Ag. Ex. 108).

Evidence submitted by the Union does not contradict the chronological sequence of events detailed in the Agency's exhibits. However, the Union has submitted a substantial amount of evidence which, it claims, establishes the Agency's failure to employ all

⁹Presumably, the Agency will maintain air traffic control operations by using the old tower at the airport.

reasonable engineering and safety standards during the remediation process. In projects involving more than 100 square feet of mold contamination significant safety precautions are required. These include the use of warning signs, enclosing work areas in plastic barriers, using personal protective gear while working in contaminated areas and employing air scrubbers and negative pressure equipment to keep contaminants from migrating from contaminated areas to clean areas.

The Union's witnesses testified that none of the required safety precautions were used during the Agency's initial remediation project in 2005 and early 2006. Plastic sheeting was taped to the walls surrounding contaminated sites, but the sheeting fell down in various area and was not reattached to the walls. Employees of the abatement contractors failed to use personal safety equipment in the contaminated areas or failed to use that equipment properly. Various employees of the contractors were observed wearing protective coveralls, but not zipping them to neck level. Others failed to wear the cloth hoods attached to the coveralls, thereby allowing mold to adhere to their skin and hair.

Likewise, the Agency used a biocide without warning its employees of the noxious or toxic nature of that chemical. The Agency did nothing to ameliorate the effects of the chemical until employees had become physically ill. The chemical, itself, was not

as described on the MSDS, but contained benzene, a known toxic chemical. (Un. Ex. 23, 25)

The Union's experts, Wonder Makers⁹, performed air quality tests during the early stages of the remediation process. It found that because the contractors were not employing proper safety techniques, they could have been spreading mold spores throughout the building, including areas that were not previously contaminated. (Un. Ex. 26). The Agency's decision to chemically treat, but not remove porous wallboard, likewise, increased the potential for additional contamination of the building. (Un. Ex. 50, 126, 142, 144, 167, 204) When the Union notified the Agency of deficiencies in safety procedures, and even offered to provide air scrubbers to the project, the Agency failed to respond to the Union's concerns and rejected its offer of air scrubbers. (Un. Ex. 50, 142, 165-67, 204, 394)

Likewise, the Agency has become increasingly less cooperative with the Union as remediation efforts have proceeded. The initial discovery of the mold problem was made by the safety committee which consisted of both Agency and Union representatives. Although that committee has continued to conduct inspections, the

⁹Wonder Makers' representative, Dr. Michael Pinto, was the Union's primary witness at the arbitration hearing. Dr. Pinto received his PhD from Kennedy Western University, a "long distance university" which offers its courses by computer to remote locations. Pinto is the author of numerous books and articles on the causes, effects and remediation of mold contamination in buildings. He has also lectured at numerous courses and seminars, has served as a consultant to the Agency and other organizations with respect to mold contamination issues and has overseen a number of remediation projects. The Union's critique of the Agency's remediation efforts is based largely upon Pinto's testimony.

Agency has ceased allowing Wonder Makers to participate in planning or decision-making. It has allowed Wonder Makers to participate in inspections, but it has not allowed anyone representing the Union to take photographs or conduct air sampling tests in the facility. Wonder Makers' recommendations to remove the interior wall board lining of the elevator shaft have been disregarded, even though such measures have been successful in removing mold contamination in other similar facilities and are recommended in various texts and guides concerning mold remediation. (See, Un. Ex. 11-16) Wonder Makers' recommendations that air scrubbers and negative pressure techniques have also been disregarded.

Having reviewed the Agency's reports, some photographs and the statements of witnesses, Pinto has concluded that the Agency's efforts to eliminate the mold have been poorly conducted. He believes that because the Agency has failed to remove contaminated wallboard from the elevator shaft and has failed to identify the source of the moisture that is fostering mold growth, the Agency's efforts to date have been less than fully effective. Five or six employees have continued to report mold related illnesses, such as asthma and allergies¹⁰. Therefore, Pinto testified, he believes the building is still contaminated.

¹⁰Pinto acknowledged that there is no existing medical evidence that allergies and asthma are caused by mold, even the so-called black or toxic mold species.

Controller Louis M. Bird testified that since January, 2005, he has noticed that he and a number of other controllers in the cab suffer from coughing, sneezing and itching while they are at work. The symptoms decline after the controllers leave the cab and return to their homes. Likewise, controller Robert Haefner testified that until September, 2004, he was in "excellent" health. Since that time, he has suffered headaches, sinus congestion, rashes, pharyngitis and a collapsed lung. He has been diagnosed as having chronic inflammatory illness due to exposure to black mold. Kim Eberhart testified that he is medically unable to work due to allergies, asthma and reactive air way disease brought on by the mold contamination. He is currently on leave and receiving Workers' Compensation benefits. Various other employees also testified that since January, 2005, they have suffered a wide range of symptoms, including allergic reactions, asthma and reactive airway disease, all of which they attribute to the mold contamination in the facility.

Tim Herrin, a certified industrial hygienist for Gandolph Associates, testified on behalf of the Agency. He testified that there is no single standard of care for mold remediation, but that the standard varies from situation to situation. He believes the Agency has taken all reasonable precautions to assure that the facility is not contaminated.

POSITIONS OF THE PARTIES

Union Position

Article 53 of the Collective Bargaining Agreement, coupled with the provisions of FAA Agency Order 3900.19B impose special obligations upon the Agency to take all reasonable actions to assure the health and safety of employees at the Detroit Tower and TRACON facility. The Agency has failed to comply with those obligations and it should be "made to correct the problem in a proper manner."

Under the contract and applicable statutes, rules and orders, the Agency is required to furnish to employees places and conditions of employment that are free from recognized hazards that may cause death or serious physical harm. It is required under the contract to make "every reasonable effort" to provide a safe and healthful working environment. Mold is a recognizable hazard which the Agency is required to remediate or abate. See, AFGE and DHHS, SSA, 89 FLRR 2-1428 (1989); Dept. Of the Treasury, IRS, Philadelphia Service Center and NTEU, Chapter 71, 41 FLRA 710 (1991); AFGE Local 1164 and SSA Region 1, 101 FLRR 2-1122 (1999).

In determining whether the Agency has complied with its obligations, the focus of attention should be on the nature and extent of the hazard and of the safety precautions taken by the Agency, rather than upon the number of employees who may have been affected by an unsafe or unhealthy condition. The Agency is required to assure that proper safeguards are in place during

construction, abatement or remediation procedures. Those safeguards include notifying the Union or the employees when chemicals are being used, accommodating employees whose health may be affected by the chemicals and using the chemicals in accordance with manufacturers' guidelines. In determining how to assure employee health, the Agency must not only apply its own Orders and procedures, but it must also apply the standards adopted by OSHA and the "consensus standards" or "industry standards" applicable to the hazard involved.

It is generally accepted that molds can create dangerous or unhealthy conditions in a work environment. The so-called black molds, or toxic molds pose the greatest threat to workers. However, other types of molds may incite allergic reactions or may indicate the existence of moisture problems which, if not solved, will lead to more serious mold infestations. Many organizations, including OSHA, EPA, the New York Dept. Of Health and the Centers for Disease Control and Prevention all warn of the need to prevent mold exposure and workplace contamination.

The Union acknowledges that there are no federal regulations governing the mold remediation industry. However, the absence of regulations does not indicate that there are no standards applicable to the industry. The Agency has agreed to follow EPA, OSHA and industry standards in removing mold contamination. All standards agree that mold cannot be effectively

abated unless the source of moisture in which molds breed is identified and eliminated. Safeguards must be in place during remediation to prevent the spread of mold contamination and to protect workers in contaminated buildings. Dr. Pinto testified, without contradiction, that employee safety is the primary objective of mold remediation and that the goal of all remediation efforts is to enable employees to work in the facility "without the continuation of symptoms" of mold exposure.

The authorities generally agree that when remediation is completed, there should be no visible signs of mold growth within the facility. Remediation is not considered effective unless the mold levels within the facility are equal to or less than those found in the ambient outside atmosphere. OSHA advocates the removal of porous materials that are contaminated, rather than the chemical treatment and cleaning of those materials. Thus, wallboard that has been contaminated should be removed and replaced with uncontaminated materials. The EPA recommends that containment procedures be utilized to prevent the spread of mold spores and dust from contaminated areas to uncontaminated areas within a facility. Those procedures include the use of impermeable barriers, HEPA air filtration systems and negative air pressure systems during remediation. All potentially affected areas should be continuously monitored and visually inspected to determine the

presence of mold contamination and to assure that all contaminated areas are decontaminated.

The Agency has failed to comply with the generally accepted and reasonable standards for mold remediation. In particular, the Union asserts, the Agency has failed to locate the source of the water infiltration in the facility that has led to the growth of mold colonies. The pattern of water stains within the facility indicate that water has infiltrated the building over an extended period of time and continued to occur even after remediation efforts were commenced. There is no evidence in the record that the Agency has resolved the problems of water infiltration, and, in fact, there is evidence that infiltration continued as late as May, 2007 (See, Un. Ex. 110 and 116)

Additionally, the evidence establishes that on numerous occasions, contractors and Agency representatives failed to comply with basic containment procedures. During the initial remediation efforts in early 2005, the contractor failed to place containment barriers around areas that were being treated for mold contamination. Warning signs were not placed in or around the work areas and even when barriers were placed in work areas, the barriers were allowed to fall out of place and were not put back in place. Contaminated wallboard was not removed and replaced until May, 2005 (Un. Ex. 29) and the wallboard was never replaced in the

elevator shaft. Instead, the Agency elected to spray a chemical in the elevator shaft without warning employees of the potential hazard created by the chemicals and without taking any precautions to assure that chemical fumes would not affect employee health. It was only after employees fell ill that the Agency decided to evacuate the facility and use air scrubbers to remove the noxious chemicals from the building.

The end result of the Agency's remediation efforts in early 2005, the Union contends, was an exacerbation of the situation. According to Pinto, mold spores were found in air samples taken on the 10th floor after the chemical treatment, whereas there had been no infiltration onto that floor prior to the chemical spraying of the elevator shaft. During the process of spraying the elevator shaft, the Agency actually spread mold spores to areas not previously contaminated, thereby placing employees in greater jeopardy than had previously existed.

As the remediation projects continued, the Union argues, the Agency demonstrated its "lack of respect for the employees' health and safety." On various occasions, the Union asked the Agency to adopt more stringent containment and safety standards, and it even offered to pay for air scrubbers to be placed in the facility. The Agency did not respond to the Union's requests and it, in fact, declined the Union's offer to provide air scrubbers. Over time, the Agency became less cooperative with the Union, so

that it ultimately refused to allow Pinto to observe or participate in the remediation projects and it failed to keep the Union informed of the progress being made in eliminating mold contamination. The Agency's disregard for employee health and safety continued even after employees complained of the ill effects they were suffering.

Under the Collective Bargaining Agreement, the Union argues, the Agency has a duty not only to eliminate existing mold colonies, but also to assure that the facility is safe and healthful on an ongoing basis. The Agency has failed to assure either that the existing mold has been removed or that the facility is safe and healthful. In particular, the Agency has refused to remove the inner lining of the elevator shaft, despite the continuing presence of mold in the shaft. All of the relevant authorities recommend that contaminated porous materials, such as gypsum board be removed and not merely washed or sanitized. The Agency refuses to remove wallboard in the elevator shaft despite the previous contamination of that wallboard and the undisputed evidence that the wallboard has been saturated with water. Even if there are no visible signs of mold on the exterior side of the wallboard, it is highly likely that mold is growing between the layers of wallboard in the elevator shaft. No effort has been made to remove the saturated wallboard.

Likewise, the Agency has failed to identify and eliminate the sources of moisture in the facility, particularly in the elevator shaft. All of the experts agree that remediation cannot be effective unless the source of moisture is eliminated.

Reviews of the remediation projects by OSHA, NIOSH and the Assistant Inspector General do not support the Agency's claim that it has made every reasonable effort to abate the mold problem. Those reports confirm that the source of water intrusion has not been identified. At least one of the reports was prepared without input from employees who are suffering from mold exposure, and none of the reports addressed Wonder Makers reports that containment practices were deficient during remediation. Likewise, none of the reports considers the obligations of the Agency under the Collective Bargaining Agreement to utilize "consensus standards" in evaluating the progress of the remediation projects.

In sum, the Union argues, the Agency has failed to employ the applicable standards in planning and executing its remediation project. It has failed to remove contaminated porous materials, to eliminate moisture intrusion into the building or to continuously monitor the building to determine if mold contamination remains. It should be ordered to take all steps reasonably necessary to assure that the building is free of mold contamination and will not become contaminated in the future.

Because the facility has been continuously contaminated by black or toxic molds and because the Agency employed improper procedures in attempting to chemically eliminate the mold contamination, the Union argues, all members of the bargaining unit are entitled to hazardous duty pay. Hazardous duty is defined in 5 CFR 550.902 as duty "involving. . . exposure to fumes, dust or noise that causes nausea, skin, eye, ear or nose irritation." Hazardous duty pay is owed if the employee subjected to such exposure is required as a part of his job duties to work in an environment that involves such exposure, unless exposure to fumes or chemicals is taken into account as part of the process of classifying the employees' jobs. The job description for Air Traffic Controllers does not include any duties or responsibilities involving the use of noxious or harmful chemicals or mold, but they have been required to accept exposure to molds and chemicals in order to perform their normal duties. Under such circumstances, the arbitrator possesses the authority to order the Agency to petition OPM to allow it to pay hazardous duty pay because employees have suffered actual exposure to hazardous or noxious fumes. In particular, those employees who were working in the cab or TRACON on January 22, 2005, when chemical fumes forced the evacuation of the facility should receive hazardous duty pay for the time they were exposed to the chemical vapors.

The Agency's witnesses testified that members of the bargaining unit could not have fallen ill due to exposure to toxic chemicals. Those witnesses testified that the MSDS for the chemical involved does not list any harmful chemical as a constituent of the MILGO-SR that was purportedly sprayed in the elevator shaft. That contention is belied by the fact that members of the bargaining unit actually became ill when the chemicals were sprayed, the MSDS upon which the Agency relies is not the appropriate MSDS, and no one from the Agency actually observed whether the contractor was using MILGO-SR or some other substance. The substance that was purportedly used included benzene, a chemical which appeared on neither of the MSDS documents presented at the hearing of this matter.

The Union also seeks relief for the Agency's failure to assure that the Union office on the tenth floor of the facility was safe and healthful. It asserts that there is no dispute that the office was contaminated by mold, including black or toxic mold. Although the Agency initially offered to relocate the office, it reneged when the Union raised questions concerning the safety of moving contaminated materials and requested the Agency to test the contents of the office for contamination and abate any mold contamination that was found. Ultimately, the Union was forced to obtain and pay for tests and abatement efforts for all of the contents of its office.

Having proven that the Agency has not only failed to comply with its own policies and procedures for mold abatement, but also has failed to comply with Article 53 of the Collective Bargaining Agreement, the Union seeks extensive remedies. Specifically, it asks the arbitrator to order the Agency "to comply with Article 53 and FAA Order 3900.19B. The Agency should be ordered to "promptly develop and implement a remediation plan consistent with the consensus standards of the industry. The plan should include at least the following:

- "1. Identification (if not done) and correction of the water intrusion in the elevator shaft and anywhere else in the . . . facilities;
2. The removal of all porous materials including gypsum board, wallboard and elevator shaft liner that was and is infected with mold contamination;
3. a reengineering strategy for the abatement plan to adjust for hidden mold if it is found. . .
4. Enactment of safety measures in compliance with the size of the project. . .
5. post-remediation air testing to make sure that overall mold count has gone down as compared to outdoor species and that the rank order of the mold is the same.
6. A mechanism to re-examine the project if employees remain symptomatic after the remediation is allegedly completed;
7. NATCA be provided copies of the remediation plan before implementation, allowed to observe the remediation process and take pictures during the process as well as be provided copies of test results and report."

Additionally, the Union requests that the Agency be ordered to continuously monitor for potential mold and water intrusions in the facility and conduct periodic air tests of the facility. Employees who inform the Agency that they are predisposed to mold related

illnesses should be accommodated by being assigned work in areas that are not exposed to mold contamination. The agency should be required to use air scrubbers and other safety equipment. The Union should also be reimbursed for the expenses it incurred in locating and removing all mold contamination in its office and its property located in the office.

With regard to payments to employees, the Union requests that all employees who worked in the facility on January 22, 2005, be paid hazardous duty pay for all time spent in the tower and TRACON facilities. Employees who took sick or annual leave due to the chemical exposure should have that sick leave restored to them. If necessary, the arbitrator should order the Agency to petition OPM to allow hazardous duty pay for January 22, 2005.

Agency Position

The overriding issue in this case is whether the Agency "failed to make every reasonable effort to provide and maintain safe and healthful working conditions from September 2004 to present as it relates to the discovery, pre-abatement and abatement of mold in the Detroit Tower and TRACON facilities under the terms of the parties' Collective Bargaining Agreement." The Union's case "is flawed in three fundamental respects." First, the Agency argues, "the Union['s statement of the issues presented improperly seeks to impose contractual obligations on the Agency that simply do not exist." Secondly, the Union has failed to meet its burden

of proving that a contract violation occurred. Finally, even if it is assumed that the Union has established a contract violation, "almost all of the remedies that the Union demanded. . . are either unavailable through Arbitration or the Union failed to present evidence to prove an entitlement to them."

The Agency acknowledges (Ag. Br. p. 19) that it has an obligation under law to comply with the various Agency orders, executive orders, and other regulations upon which the Union relies. However, it argues that obligation is not a contractual obligation enforceable through the grievance and arbitration process. Rather, "proposals that paraphrase or set forth the terms of a Government-wide regulation are distinguishable from proposals that merely require an agency to comply with existing Government-wide regulations." In the first instance, a contractual obligation is established. In the latter instance there is no contractual obligation but merely the obligation of all Agencies to abide by the law which controls them. AFGE Local 3509 and Social Security Administration, 46 FLRA 1590 (1993)

The issue presented in this case is an issue of contract interpretation. Therefore, the burden rests on the Union to establish by a preponderance of the evidence that the Agency has violated the contract. The Union has failed to meet its burden of proof.

The Union's principal witness at the hearing was Michael Pinto of Wonder Makers. The Union presented Pinto as an expert witness concerning mold remediation and abatement procedures. Pinto has no technical education except a PhD from a "long distance learning" institution. He is not a Certified Industrial Hygienist, a Registered Environmental Health Specialist, a Registered Sanitarian, a licensed engineer, or a Board Certified Environmental Engineer. He also has no formal medical training or training in microbiology or public health, and he is not a chemist. The laboratory at Wonder Makers is not an accredited environmental laboratory. In short, the Agency submits, Pinto lacks the credentials to establish expertise in any of the subjects about which he testified.

Pinto offered substantial criticism of the Agency's efforts to abate the mold in January 2005. At the time, the Agency agreed with most of Pinto's criticisms. Because it was concerned about the quality of the work being performed, it contracted with a Certified Industrial Hygienist to oversee the remediation work as it was being performed by the contractor, Coach's Catastrophe Cleaning & Restoration Services. Because the Agency found Coach's work to be unacceptable, it immediately hired another remediation company, which was recommended by Pinto, to correct Coach's work. Coach's failure to perform the remediation work properly was noted

by the Agency and was immediately remedied by the hiring of an Hygienist and a new contractor to abate the mold.

On January 22, 2005, the facility was evacuated because fumes from the chemical being used to abate mold in the elevator shaft was causing employees to become ill. Management acted reasonably in evacuating the tower, having first learned of the problem at approximately 12:55 p.m. and having issued the order to evacuate the facility at 1:40 p.m. Employees were not allowed back into the tower until the Fire Department had taken air samples and the Agency had placed an air scrubber in the Tower CAB. In light of the difficulty involved when an airport tower is closed and reopened a few hours later, the Agency's actions to prevent employees from being exposed to dangerous chemicals were reasonable.

The Agency asserts that Pinto's critique of the Agency's remediation efforts is not based upon personal knowledge of the situation. Much of Pinto's criticism was based upon photographs taken by others, as to which he had no information concerning the context of the photographs. He did not know what had occurred either before or after the photographs were taken. For example, Pinto was critical of the Agency's purported failure to maintain strict containment of the abatement areas. While there were breaches in the containment barriers, those breaches were repaired as soon as they were discovered. Pinto complained that the Agency

did not engage in monthly air sampling, but he failed to note that the Agency conducted repeated air samplings, including one sampling within a week after the 2005 remediation began. Air quality was tested in January, 2005, once in March, twice in May and once in June. Moreover, NIOSH has noted that air sampling is an ineffective means of determining the presence of mold contamination. There are no nationally recognized criteria for interpreting the data received as a result of air samples. At best, air samples may be used to compare one area of a facility with another, or with the outdoor air. According to NIOSH, the sample results have not been shown predictive of medical problems in individuals exposed to mold contamination.

Pinto testified that the Agency's efforts were deficient because the Agency failed to identify the source of moisture in the tower. In fact, the moisture abatement expert hired by the Agency issued his report in August, 2005, and made numerous recommendations for the prevention of moisture incursions into the building. All of the recommendations were adopted and followed by the Agency.

After the May, 2005, abatement process, Pinto had additional criticisms of the Agency's efforts to abate the mold. The record of monitoring and testing in 2005, reveals that as of May, mold spores could be found only in part of the 10th floor. All other mold had been removed or abated.

One of Pinto's major criticisms of the remediation efforts made after May, 2005, was that the Agency refused to remove and replace the inner lining of the elevator shaft, at least in those areas where mold was known to be present. The inspectors found in June, 2006, that no viable mold colonies continued to exist in the facility, and that the wallboard, itself was dry and uncontaminated by living spores. The EPA has also indicated that removing and replacing wallboard is one, but not the only, method of mold abatement. Sanitizing the affected areas is an acceptable alternative if the drywall has not been significantly damaged by water or mold.

The Union has also failed to support its claim that mold contamination at the facility has had adverse effects on employee health. Ten employees testified that their health has been affected by the mold contamination, but the Union presented medical evidence to that effect with respect to only one of those employees. In cases involving alleged exposure to toxins, the burden rests upon the proponent of the claim to establish that he was exposed to a toxin, that the toxin is capable of causing the particular illness of which the proponent complains, and that the proponent was exposed to sufficient levels of the toxin to have caused his illness. Parker v. Mobil Oil Corp., 837 N.E.2d 1114 (NY, 2006); Bpgmer v. Titleist Club, LLC., 2006 Ohio - 7003 (Oh. App., 2006); Gass v. Marriott Hotel Services, Inc., 2007 WL 1343675;

Kemmerer v. State Farm Insurance, 2004 WL 87017 (E.D. Pa. 2004; Allison v. fire ins. Exchange, 98 S.W. 3d 227 (Tex. App. 2002). At best, the Union has proven "general causation" through Pinto's testimony that "black mold" is capable of causing illness. The Union has not established that any of the employees were in contact with living mold spores or that the contact, if it occurred was sufficient to cause the ailments of the employees.

Moreover, the Union's medical evidence ignores the possibility that elements other than mold may have caused the ailments about which Plaintiff's witnesses testified. In order to prevail on its primary claim, the Union was charged with the burden of establishing a connection between mold in the facility and the employees' illnesses. Unless other hypotheses can be ruled out as possible explanations for the employees' symptoms, the Union will be unable to prove the causal nexus between the presence of mold and the illnesses suffered by the employees. See, Cavallo v. Star Enterprise, 892 F.Supp. 756 (E.D. Va. 1995). In light of the fact that only 16 employees of almost 200 were suffering mold-related symptoms, it is likely that causes other than mold in the workplace had affected the health of the employees.

Even if the Union had proven that the Agency violated the contract, the Agency asserts, none of the remedies requested by the union is proper. The Agency contends that the Union has made 55 requests for relief in the five grievances, including requests

duplicated in more than one grievance. The requested remedies may be divided into eight general categories.

The "principal remedy" sought by the Union is its request that the Agency grant substantial control over the mold abatement process to the Union. For example, in grievance GL-05-118 (Jt. Ex. 4) it demands that the Agency to immediately seal contaminated rooms and elevator shafts until the abatement process is completed. Other grievances request that the Agency be ordered to allow the Union and its designees to test, evaluate and inspect the facility (Jt. Ex. 9), to observe and/or participate in all evaluations and remediation work (Jt. Ex. 10) and install air scrubbers in various areas designated by the Union. (Jt. Ex. 12) Overall, the Union asks that the Agency be ordered to make the Union "an equal collaborator" in formulating and executing a mold remediation plan.

Under the law and the Collective Bargaining Agreement, the Agency contends, management of the Agency's facilities is vested solely in the Agency. The Agency's safety responsibilities are not a subject open for bargaining or negotiations. Therefore, an arbitrator may not properly order the Agency to collaborate with the Union concerning safety issues. See, NFFE Local 2052 and Bureau of Land Management, 30 FLRA 797 (1987); AFGE Local 1345 and Ft. Carson, 48 FLRA 168 (1993). The Union may not obtain through arbitration rights which it may not obtain through negotiation. Therefore, any request by the Union to become a participant in the

abatement process, or to dictate the manner or means by which that abatement is to be achieved cannot be awarded by the arbitrator.

The Union may ask OSHA to determine whether abatement is required, whether the Agency's remediation plan is adequate and whether the Agency's implementation of the plan is sufficient. It cannot usurp management's rights by seeking remedies through an arbitrator that it could not bargain for at the bargaining table.

The second category of relief requested by the Union pertains to the use of its experts and consultants. It asks that the arbitrator order the Agency to grant the Union's consultants access to the facility and to permit those consultants to engage in air quality and other testing within the facility. That same relief was the subject of an Unfair Labor Practice charge filed by the Union in April, 2006 and resolved by a settlement agreement (Ag. Ex. 105) in November, 2006. The Union's request, therefore is rendered moot by the settlement agreement.

The Union also requests that all employees be restored sick leave eligibility for the period during which the mold problem has remained unresolved¹¹. However, the Union has failed to present evidence showing that any employees actually used sick leave as a

¹¹In various grievances, the Union has phrased its request differently. Thus, in GL-05-072 (Jt. Ex. 2), it requested restoration of 120 hours of sick leave eligibility, while in GL-05-986, it requested restoration of sick leave used by bargaining unit members from January, 2001, until the remediation is completed.

result of an Agency action. Therefore, the Union is not entitled to the relief it requests.

Likewise, the Union's request that employees be reimbursed for medical expenses, including travel to doctors' offices, prescriptions and over the counter medications, should be denied. The Union has failed to present evidence substantiating that any employees incurred such expenses in connection with the mold contamination. Moreover, the FLRA has held that these types of damages are payable, if at all, through the workers' compensation system, and not through the grievance and arbitration process. Internal Revenue Service and NTEU Chapter 71, 41 FLRA 710 (1991); Internal Revenue Service and NTEU, 40 FLRA 633.

The Union has also requested that members of the bargaining unit be paid hazardous duty pay¹². That remedy would be improper because members of the bargaining unit have not performed hazardous duty. The FLRA has held that hazardous duty pay is awarded under OPM regulations when employees are assigned to irregular or intermittent duties involving "working with or in close proximity to toxic chemical materials". In the present case, no employee was assigned duties which required her to work with or

¹²Once again, the Union's request appears in various forms. One grievance requests hazardous duty pay solely for time worked by members of the bargaining unit in the tower on January 22, 2005, when the infiltration of chemical fumes resulted in evacuation of the tower. Another seeks hazardous duty pay for the entire period the mold contamination has remained unabated.

in close proximity to toxic chemical materials. Moreover, there is no evidence that employees were exposed to toxic chemicals.

Because there is no evidence that any employee lost the opportunity to work premium pay hours as a result of the mold contamination, the Union's request for lost premium pay should be denied. Additionally, under the Agency's appropriations acts, employees may be paid premium pay only for hours actually worked, and any award of "lost" premium pay would be contrary to law. See, FAA and NATCA, 60 FLRA 20 (2004).

Finally, the Agency asserts, there is no basis for the Union's request to be reimbursed for the expenses it incurred in connection with cleaning its 10th floor office. The Collective Bargaining Agreement requires the Agency to make a work area available to the Union if space is available. It does not require that the Agency perform any other duties with respect to the space it provides. The arrangement is not a leasehold arrangement subject to the common law and statutory duties of landlords to tenants. It does not impose upon the Agency any obligation to maintain the Union's office. Therefore, the expenses incurred by the Union in connection with cleaning its office should be borne solely by the Union.

In sum, the Agency contends, it "understands that the Union, and its paid consultant, Mr. Pinto, would have preferred that it handle the mold issue at the Detroit facility differently."

However, the Agency did not bind itself to comply with the Union's preferences or Pinto's recommendations. Rather, the Collective Bargaining Agreement requires the Agency to "implement governmental health and safety standards," and not the subjective preferences of the Union or its experts. The arbitrator's role is to determine whether the Agency responded to the mold contamination problem in a reasonable way, not in a way which is preferred by the Union.

During the almost three years since the mold problem was first identified, four independent agencies have investigated the situation. None of them has found that the Agency was failing in its duty to provide a safe and healthful work environment to its employees. OSHA has issued no citations for improper handling of the mold problem. The Office of the Inspector General has approved of the Agency's remediation plan and has urged the Agency to continue implementing that plan. NIOSH has found no medical evidence supporting employees' claims that their health has been adversely affected by the mold. Finally Federal Occupational Health has found that the abatement activities conducted at the facility were properly and safely performed to ensure the health and safety of the employees. The grievances should be denied.

DISCUSSION

During a routine inspection of the Tower and TRACON facility at Detroit Metro Airport in September, 2004, the parties'

discovered that mold colonies had become established in storage rooms on two of the floors of the facility. That discovery has now led to five grievances, an unfair labor practice charge, three inspections by outside agencies, four abatement or remediation plans and the expenditure of tens, if not hundreds of thousands of dollars. The five grievances are presently before the arbitrator for determination.

Most of the facts concerning all five grievances are not in contention. There is no dispute that a mold infestation was discovered in September, 2004. Mold was found on the inner walls of two storage rooms and in the inner lining of the elevator shaft. Among the mold species found in the colonies were at least two species that are known as "black" or "toxic" molds, as well as other species which are common in the environment. It is generally accepted that the black mold species may cause illness in humans, particularly allergic reactions, asthma and respiratory problems. The scholarly works do not agree whether only the active or viable spores of the black molds may cause health problems, or whether the dead or inactive spores also may cause reactions in humans.

There is no dispute that before the mold contamination was discovered, none of the members of the bargaining unit complained of symptoms of mold reaction. Since the discovery of the contamination, 16 of the more than 140 employees in the facility have complained of symptoms which may be attributed to

exposure to black mold. One doctor, a specialist in mold borne disease, has stated his opinion that the members of the bargaining unit who have been examined by him were suffering from mold related illnesses. Other doctors who have examined members of the bargaining unit have been less definite in their opinions, but have offered the opinion that their patients' ailments might be attributable to airborne contaminants, such as black mold.

After the contamination was discovered, the Union consulted with its expert, Michael Pinto, of Wonder Makers. Pinto was permitted by the Agency to participate in inspections conducted in late 2004, and to offer suggestions and proposals for the remediation of the mold contamination. During subsequent inspections, Pinto was not allowed to observe and the Union was not allowed to take photographs. Three of the four remediation plans ultimately adopted by the Agency were created without Pinto's input and without his having observed the inspections. After an unfair labor practice charge was filed by the Union (Ag. Ex. 105), the parties entered into an agreement dated November 21, 2006, whereby the Agency agreed to allow Pinto to have access to the facility for purposes of conducting independent tests to determine whether the mold contamination had been abated and for the purpose of observing the tests performed by the Agency or its experts.

The first remediation plan was adopted in late 2004, and the work was performed in early 2005. By all accounts, the

remediation effort was unsuccessful and was poorly performed. The plan called for washing the contaminated areas and removing contaminated drywall from the storage rooms. The contractor was required to prevent further contamination of the facility by enclosing the work area in plastic and using other methods to prevent contaminants from entering into the rest of the building. On various occasions during the remediation, the contractors failed to employ proper containment techniques, allowing contaminated materials to be hauled out of the building on open wheel barrows, allowing the plastic sheeting to fall down and not be re-sealed, and allowing employees to enter and leave the containment field without using appropriate personal protective equipment.

On January 22, 2005, the contractor used a chemical wash to cleanse the interior wall of the elevator shaft. It is not clear whether the contractor used the proper chemical mix or made the mixture in proper proportions. Employees in the tower and TRACON were not informed that the chemical wash was being used, and they were not given any instructions to avoid contact with the chemical or its fumes. Ultimately, the fumes infiltrated the tower cab, causing a number of employees to feel ill. As employees began complaining, management decided to evacuate the building and move operations from it to the old tower facility elsewhere on the airport site. Some employees were sent home during their shift because they were feeling too ill to work. Others evacuated the

building and continued their shifts at the old tower. The tower was reoccupied later in the day, after the Fire Department had determined that none of the dangerous gasses it could test for were present in the tower¹³, and after air scrubbers had been brought in to filter the air and force the noxious fumes out of the cab.

Over the following two years, the Agency, with the advice of the EPA, the Office of the Inspector General and other agencies, as well as outside contractors and Certified Industrial Hygienists, developed three additional remediation plans. Each plan involved increasingly extensive work both inside and outside the building. Contaminated areas were washed, damaged drywall was removed from the offices and storerooms, air filtration systems were temporarily installed in the building, and the air quality was monitored.

The contractors employed in those remediation efforts were required to use proper containment technology, including the sealing of infected areas, the use of personal protective equipment and the use of plastic containment materials. Although the appropriate procedures were generally followed, there were breaches in the procedures at various times. For example, some of the plastic sheeting became detached and was not immediately restored to its proper place. Some of the contractor's employees failed to wear the hoods that are attached to their personal protective

¹³The Fire Department tests were able to determine whether carbon monoxide, natural gas and other chemical contaminants were present. The tests could not be used to detect the presence of the chemicals purportedly contained in the chemical wash.

equipment, thereby risking contamination of their hair with mold spores and then carrying those spores out into the building when leaving the containment area. Other Agency employees were allowed to enter the containment area without protective equipment, and not all contaminated areas were continuously marked with warning signs.

Early in the process, it was determined that moisture had been puddling at various locations in the elevator shaft. That moisture was deemed the source of the mold contamination in the elevator shaft. Other walls inside the building showed evidence of water infiltration at or near the areas where mold colonies had grown. There was general agreement among all entities involved that all efforts to remove the mold would be mere temporary solutions unless the infiltration of water and moisture into the building could be resolved. Nonetheless, the remediation efforts undertaken in mid and late 2005, continuing until May, 2006, did not include any plan to determine the source of or eliminate the infiltration of water.

The final remediation plan adopted in 2006 addressed the moisture problem. Management and its advisors surmised that moisture was infiltrating the building through cracks in the concrete foundation and walls of the building and through the seals between the windows, vents and other exterior outlets of the building and the walls and roofs to which they were attached. They

also concluded that moisture was collecting in the elevator shaft as a result of condensation caused when cold air and warmer air mixed in the elevator shaft as the elevator cab moved up and down in the shaft. Therefore, the 2006 remediation plan called for a visual inspection of the entire building to locate all cracks and unsealed seams. It called for the cracks to be sealed and for the seams between the concrete panels comprising the exterior walls of the building to be caulked and made water tight. Likewise window seals, vent seals and other joints were to be re-caulked and sealed. Finally, heaters were to be installed in the elevator shaft, so that condensation would be less likely to occur. That work was completed in February, 2007.

By the end of February, 2007, all visible mold colonies within the building had been removed. In some instances, the contamination was removed by washing the walls or infected areas. In other locations, contaminated drywall was removed and replaced with new drywall. All visible cracks in the concrete exterior of the building had been sealed and all joints in the exterior wall had been caulked or sealed. Finally, heaters had been installed to moderate the temperature variations within the elevator shaft, so that moisture would not condense and puddle in the elevator shaft. The Agency had agreed to periodic monitoring of the air quality within the building, as well as regular inspections of visible areas to detect any signs of mold contamination. Nonetheless, the

Union asserts that the Agency has failed to provide a safe and healthful work environment.

The largest area of dispute concerns the elevator shaft. When mold was first discovered in the elevator shaft, it had grown on the exposed wallboard facing the open area of the shaft. There were signs that the wallboard had been "wicking" water from puddles on the flooring and beams of the elevator shaft. Pinto advised the Union that water damage to the wallboard itself was likely, and that there may be mold growing inside the wall. The Union has consistently requested that the interior liner of the shaft be removed and replaced with non-porous materials or new fire rated drywall. The Agency has declined to remove and replace the liner because, it contends, the fire safety of the elevator shaft could be compromised, and the elevator would have to be closed and sealed for the time required to remove and replace the interior wallboard. It contends that any mold which was growing between the layers of the elevator shaft walls have been deprived of moisture and have died. The spores are sealed inside the wall and cannot cause harm.

The Union counters that the generally accepted remediation standards call for the removal and replacement of all contaminated or water-damaged porous materials. Therefore, the liner of the elevator shaft should be replaced. The parties' dispute concerning the lengths to which the Agency must go to remediate the mold is at the core of the present grievances.

The bulk of the Union's contractual claim rests on Article 53 of the Collective Bargaining Agreement. It provides:

**ARTICLE 53
OCCUPATIONAL SAFETY AND HEALTH**

Section 1. The Agency shall abide by P.L. 91-596 and Executive Order 12196, concerning occupational safety and health, and regulations of the Assistant Secretary of Labor for Occupational Safety and Health and such other regulations as may be promulgated by appropriate authority.

Section 2. The Agency shall make every reasonable effort to provide and maintain safe and healthful working conditions. Factors to be considered include, but are not limited to, proper heating, air conditioning, ventilation, air quality, lighting and water quality.

Section 9. In the event of construction or remodeling within a facility, the Agency shall insure that proper safeguards are maintained to prevent injury to bargaining unit employees.

In general terms, the grievances assert that the Agency violated Sections 2 and 9 by failing to make every reasonable effort to "provide and maintain safe and healthful working conditions" within the facility, and by failing to "insure that proper safeguards are maintained to prevent injury to bargaining unit employees."

Section 1 amplifies those requirements. It requires the Agency to abide by P.L. 91-596, which requires agencies to furnish "a place of employment which [is] free from recognized hazards," to comply with OSHA standards and with Executive Order 12196. EO 12196 requires agencies to "furnish to employees places and conditions that are free from recognized hazards," and to assure prompt "abatement of unsafe or unhealthy working conditions."

The Agency has not seriously disputed that the presence of black or toxic mold in workplace is a hazardous condition in that it may cause illness or injury to employees who are exposed to the mold spores¹⁴. It also has not disputed that it has a duty to adopt and execute an abatement plan to eliminate mold infestations when they are discovered. It also has not seriously disputed that its initial efforts to abate the mold were ineffective, but it contends that the building has been freed of harmful levels of toxic mold as a result of the four abatement plans that were executed between September, 2004 and February, 2007.

The Union disputes that contention. It asserts that the Agency has not complied with "consensus" standards for the abatement of mold in buildings inhabited by humans. It notes that during the abatement process, there were numerous violations of containment standards, that OSHA standards for the placement of warning signs, for sealing contaminated areas and for removing contaminated materials were not followed. Most significantly, it contends, the Agency has failed to comply with consensus standards by failing to determine the sources of moisture within the building and by failing to remove and replace the fire rated drywall product which lines the elevator shaft.

¹⁴The Agency has asserted that there is some dispute within the scientific community concerning the effects of toxic molds on humans. However, it is clear that OSHA and NIOSH, both agencies of the Federal Government, recognize toxic mold as hazardous and as potentially having adverse health effects on humans who are exposed to it.

The arbitrator agrees with the Union that at the time the mold infestation was discovered, the Agency owed a duty to its employees in the bargaining unit to adopt and implement an abatement or remediation plan designed to eliminate the toxic mold species that had been discovered. Article 53 requires that the employer provide a safe and healthful work environment. When a hazardous condition is discovered, Article 53 requires that the condition be remedied. The Agency's own Occupational Health and Safety order, FAA Order 3900.19B, confirms that the Agency has taken it upon itself to remediate toxic conditions as promptly and effectively as is reasonable.

Had the Agency failed to adopt or implement an abatement plan after the mold infestation was discovered, the arbitrator would have little difficulty deciding the issue in this case. The Agency would have been ordered to create and implement such a plan. However, the Agency adopted an abatement plan and put it into effect by January, 2005, a little more than two months after the mold infestation was discovered. It continued to adopt, amend and implement remediation plans throughout 2005 and 2006, finally declaring the abatement complete in February 2007. In adopting new and more stringent abatement plans between January 2005 and February, 2007, the Agency acknowledged, and the arbitrator would find, that the Agency had a continuing duty to abate the hazardous mold condition until the condition ceased being a hazard.

The Union does not claim that the Agency failed to act promptly or diligently in adopting, revising and implementing at least four abatement plans. However, it claims that the plans were inadequate and incomplete, and that the implementation of the plans was deficient. The arbitrator agrees that various of the abatement plans were inadequate or incomplete, and that there were violations of generally accepted standards for the abatement of hazardous materials such as mold and asbestos. However, the arbitrator is also persuaded that mold abatement involves a substantial amount of "art" as well as science. It is apparent to the arbitrator that as an abatement project progresses, unanticipated problems arise and must be dealt with. There is no one proper way to abate mold, but, at most, there are some generally accepted standards of behavior among those who are "experts" in the field of mold abatement.

Over the course of the more than two years the Agency has been attempting to remediate the mold problem, it or its contractors breached some of the generally accepted standards. Contamination barriers were allowed to fall out of place and not be promptly replaced, potentially contaminated materials were exposed in uncontaminated areas of the building. Workers failed to properly utilize personal protective equipment. None of those breaches has been demonstrated to have caused any recognizable damage or injury to any employee or to the Union.

Therefore, even if there were breaches, and even if the proper forum to address those breaches is the grievance process¹⁵ the Union has failed to establish that it is entitled to any remedy. Unlike OSHA and other regulatory agencies, the arbitrator lacks the authority to investigate or punish violations of agency regulations. OSHA, in particular, possesses authority to levy fines upon agencies which fail to comply with OSHA regulations. The arbitrator's authority is limited to the assessment of actual damages or losses caused by the Agency's failure to comply with the regulations. As there has been no evidence that the Union or the members of the bargaining unit suffered any actual loss or damage by virtue of the failure of contractors to use proper containment technology, the Union is not entitled to a remedy for those breaches of the abatement plans.

The Union asserts that members of the bargaining unit have suffered illness not only because various contractors failed to apply proper containment technology, but also because employees have been exposed to toxic mold throughout the two years since the first contamination was discovered. It requests that the arbitrator order the Agency to reimburse those employees for their medical expenses and restore their sick leave to them.

¹⁵The Agency asserts that violations of procedures prescribed in the regulations of other Agencies are not enforceable through the grievance and arbitration process, but through enforcement proceedings commended within the agencies promulgating the rules and standards.

The testimony of the affected employees is persuasive anecdotal evidence that the employees have suffered ill effects from the mold contamination¹⁶. However, the grievance and arbitration process is the incorrect forum in which to address the issues of compensation for medical expenses and lost work time. Undoubtedly, if the various ailments are proven to be caused by mold contamination within the workplace, they are work-related illnesses or injuries. Requests for redress for work-related illnesses and injuries are appropriately addressed to the Department of Labor under the Federal Employees' Compensation Act, the federal Workers' Compensation program. See, Internal Revenue Service and NTEU Chapter 71, 41 FLRA 710 (1991).

The Union also complains that it and its experts have been excluded from participating in the development of remediation plans and that, in fact, the Agency has refused to accept voluntary offers of assistance from the Union in performing the abatement work. The Union notes that it offered to obtain and pay for air scrubbers to assist in assuring that contaminants would not enter the facility from areas under remediation, but the Agency declined that offer.

¹⁶The Union presented no witnesses to scientifically or medically establish the connection between the employees' ailments and the mold contamination. However, one physician provided a written statement to that effect, and there is a substantial body of scientific literature reporting the connection between airborne mold and the various illnesses described by the employees.

Article 53 does not include any provision requiring the Agency to negotiate with the Union or otherwise permit the Union to participate in the formulation or implementation of abatement plans. Rather, it imposes upon the Agency the duty to use every reasonable means to assure employees a safe and healthful work environment. As a general matter, issues concerning facilities management and operation are solely within the purview of management under the management rights provision of the Collective Bargaining Agreement, as well as by statute. The FLRA has held that such matters are not a proper subject of collective bargaining. See, NFFE Local 2052 and Bureau of Land Management, 30 FLRA 797 (1987); AFGE Local 1345 and Ft. Carson, 48 FLRA 168 (1993). If the Agency has no duty to bargain its obligations to provide a safe work environment during contract negotiations, it has no duty to bargain with the Union concerning the manner in which it performs its obligations to provide a safe work environment. Therefore, the Agency's failure or refusal to permit the Union to participate in developing remediation plans is not a violation of the Collective Bargaining Agreement.

However, the Union filed an Unfair Labor Practice charge against the Agency (Ag. Ex. 105) asserting that the Agency's refusal to allow Wonder Makers to observe the February 2, 2006 inspection of the facility "puts the Union at a disadvantage" because it allows the Agency to "control what information is put

out about the seriousness of the [mold] condition. . . By not allowing the Union's experts present does not grant the Union the opportunity to properly collect data, evidence and information for the support of grievances, litigations and arbitrations."

The Unfair Labor Practice Charge was never adjudicated by the FLRA. Instead, the parties entered into a settlement agreement under which the Agency agreed to allow Wonder Makers "reasonable access" to the facility "for the purpose of conducting independent tests for mold and moisture at the facility and for the purpose of observing tests conducted by the Agency." The Agency agreed, in essence, that it would not impede the Union's ability to obtain a determination by its expert whether remediation efforts have been successful. That agreement remains in effect. The arbitrator concludes that it satisfies the Agency's obligation to address grievances concerning health conditions within the facility in good faith.

The Union cites two aspects of the remediation plans which, it contends, the Agency has failed to properly address under the existing regulations and "consensus" of scientific experts. It asserts that a proper remediation plan must include removal and replacement of all porous materials which may have been contaminated by mold or moisture. The wallboard lining the elevator shaft is considered a porous material, both by the relevant regulatory bodies and by the wallboard industry. The

Agency has not taken action to remove and replace the fire rated wallboard which lines the elevator shaft. Additionally, applicable standards require that the Agency identify the sources of moisture within the contaminated areas and take action to prevent infiltration of water into those areas.

The Agency responds that its contractual obligation is to provide its workers a safe and healthful work environment. The reference in the contract to specific orders and statutes does not carry with it the obligation, under the contract, to comply with any and all recommendations or regulations that may exist concerning mold remediation. In fact, it asserts, there is no consensus standard for mold remediation. To the extent that OSHA regulations are referenced in FAA Order 3900.19, Executive Order 12196 or P.L. 91-596, the FLRA has held that no contractual obligation pertains to those references. See, AFGE Local 3509 and Social Security Administration, 46 FLRA 1590 (1993). Rather, the agencies charged with enforcing those regulations possesses the authority to require the Agency to comply. In the present case, OSHA, NIOSH and the Office of the Inspector General have all approved the efforts made by the Agency to remediate the mold problem.

That OSHA, NIOSH and the Inspector General have approved the Agency's remediation plans does not fully resolve the question whether the Agency has employed "every reasonable effort" to

provide a safe and healthful working environment. Rather, the issue remains whether the Agency should have taken additional action to remediate the mold problem, even though its efforts satisfied the various regulators who have reviewed the remediation plans.

Under the contract, the Agency is not required to employ every "possible" means of assuring a safe and healthful work environment. It is required to employ every "reasonable" means. It asserts that it has complied with that requirement, while the Union, and its expert, Michael Pinto, assert that the Agency should have replaced all of the wallboard lining the elevator shaft and it should have identified every possible source of moisture within the structure and should have acted to make the building free of all sources of water infiltration.

The parties' use of the word "reasonable" recognizes that it is necessary to engage in a type of cost/benefit analysis in determining what measures should be taken to provide a safe and healthful work environment. The parties recognize that not every possible measure is desirable, but that the measures which should be taken are those which achieve the desired benefit at the least cost to the Agency, and ultimately to the public which relies on the Agency to assure a safe air transport system. It would be possible, for example, for the Agency to demolish the present tower and rebuild it in a different way to prevent mold infiltration.

However, there would be a substantial financial cost to such a remedy, and there would be substantial interference with the Agency's ability to accomplish its mission during the building process. On the other hand, the Agency attempted to wash the areas of visible mold contamination at a minimal cost and with little interference with the Agency's performance of its functions, but such a remedy has proven ineffective in removing the mold contamination.

The current abatement plan attempts to balance the costs of remediation against the benefits to be achieved. The Agency has adopted an approach which allows continued operation of the tower and TRACON facility with minimal interference with the operational needs of the facility, while assuring, in the opinion of the Agency's experts, that mold contamination will not affect the safety and health of employees.

The arbitrator concludes that at this point, the Agency has employed every reasonable means of abating the mold and preventing future problems. However, the arbitrator's conclusion must be tentative because sufficient information does not exist to make a final determination. As indicated by the chronological history of the remediation process, it is apparent that the remediation is a "work in progress." The Agency began its efforts by employing the least costly method it believed would solve the

mold problem. After commencing that effort, the Agency determined that its minimalist approach would not be sufficient, and it developed a more thorough approach. That process, likewise, proved insufficient and a more extensive remediation program was adopted. When that process still proved insufficient, the Agency developed its final remediation plan. The success of that plan is yet to be determined.

At present, all visible mold contamination has been removed. All porous material which is known to have been contaminated by mold has been replaced, and all potential sources of water infiltration have been sealed and made water tight. The Agency has installed ventilation and heating equipment in the elevator shaft in order to prevent the condensation of airborne moisture in the shaft. If those measures prove to have been successful, then it may be concluded that the Agency employed every "reasonable" effort to abate and prevent mold contamination. If mold contamination persists, then it may be concluded that other remediation processes are required.

Insufficient time has passed to allow the Agency, the Union or the arbitrator to determine whether the Agency's abatement

plan is successful. At this point, the facility has not been subjected to winter weather conditions, wide variations in temperatures inside and outside the facility and other climatic conditions which may demonstrate that water infiltration continues or has been prevented. Tests performed in the spring and early summer of 2007 indicate that the abatement process has been successful, but until the facility has been subjected to the entire range of conditions which it normally faces, those tests are inconclusive. Should moisture or mold infiltration recur, then it will be incumbent upon the Agency to make further efforts to remediate the problem, including, if necessary, the removal and replacement of the wallboard lining the elevator shaft and/or the redesigning of portions of the building to prevent water from infiltrating into areas where it is allowed to pool and form a breeding ground for mold.

If, after the facility has been exposed to the full range of conditions, mold and moisture infiltration do not recur, then it may be concluded that the Agency has employed every "reasonable" means of making the facility safe and healthful for its occupants. The settlement agreement concerning the Unfair Labor Practice charge is the most effective means by which the parties may ultimately determine whether further remediation is required. As Wonder Makers will be able to conduct its own tests and observe the tests conducted by the Agency, it will have access to sufficient

information to draw an informed conclusion whether the mold problem has or has not been solved. Until that time, the arbitrator finds that the Union has not proven the need for the Agency to replace the interior lining of the elevator shaft or to take other steps to prevent moisture infiltration.

The Union has requested that the members of the bargaining unit receive hazardous duty pay as a result of having been required to work in a contaminated work environment since September, 2004. It recognizes that the Agency lacks the authority to award hazardous duty pay without the approval of OPM. It appears to the arbitrator that there is some basis for the Union's request. OPM regulations permit the OPM to award hazardous duty pay under circumstances where the job description of an employee does not involve the performance of dangerous work, but circumstances cause an unusual hazard to exist. For example, a civilian air traffic controller who is assigned air traffic control duties in a war zone is not performing hazardous work, but it is apparent that he is being required to engage in hazardous duty. Whether the OPM would consider it hazardous for an air traffic controller to be required to work in a mold contaminated building is an issue which should be raised with OPM and it cannot be decided by the arbitrator. Therefore, in this case, the arbitrator defers to the OPM, but will direct that the Agency, in conjunction with the Union, formulate a request to the OPM to

approve hazardous duty pay for employees who have worked in the facility since September, 2004.

The Union also requests that employees who took sick leave on January 22, 2005, be restored that leave. The arbitrator agrees that those employees who were forced to take sick leave because the Agency's contractor failed to take appropriate measures to prevent noxious fumes from escaping the elevator shaft and entering the tower cab and TRACON should not be charged sick leave. If the Agency, through its contractor, created the need for the sick leave, it should not impose the cost of that leave upon the employee victims of the fumes. The employees who are entitled to restoration of their sick leave are those employees who were working in the facility at or before the time the facility was evacuated on January 22, 2005 and who claimed sick leave on that date. All sick leave used by them on that date should be restored and their absences should be considered as paid leave.

The Union also requests that it be reimbursed for the expenses it incurred in decontaminating the contents of its office. The Agency responds that by providing the Union with an office on a "space available" basis, and by providing the Union with office furniture and equipment as available, it did not assume the duties of a landlord, and it should not be held responsible for "damage" caused by the mold infiltration.

The arbitrator agrees with the Union that it should be reimbursed for its expenses in abating the mold infestation. The Agency's obligation under Article 53 is to provide a safe and healthful work environment. As discussed above, part of that obligation requires it to abate mold contamination, once it is aware of that contamination. The Agency could not fully abate the contamination without decontaminating the Union's office, and it could not assure that the office was not contaminated unless all mold infestations within the office were removed. The Union performed a part of that function by having the contents of the office decontaminated. As the Agency would have been required to engage in the same process if the Union had not undertaken it, the arbitrator finds that the Union should be reimbursed for the expenses it incurred in decontaminating its office.

Finally, the Union requests that it be reimbursed for the expenses it has incurred in presenting the testimony of Michael Pinto at the arbitration hearing. It asserts that the Union would not have incurred those expenses "but for the Agency's continued refusal to properly remediate the mold at the facility." The arbitrator has concluded that the Agency did not refuse to properly remediate the mold, and that it remains to be determined whether additional remediation efforts are necessary. The arbitrator does not find a basis to conclude that the Agency has acted in bad faith in taking an incremental approach to the mold remediation, rather

than immediately adopting the method proposed by Pinto. Pinto's testimony at the hearing was extensive, informative and useful, but ultimately not persuasive that the Agency has refused or failed to perform its contractual obligations. Therefore, the arbitrator finds no contractual or equitable basis for ordering the Agency to pay the Union's expenses in presenting Pinto as a witness.

AWARD

The grievance is sustained in part and denied in part. The arbitrator finds that as of the date of the hearing of this matter, the Agency has not violated Article 53 of the Collective Bargaining Agreement, subject to the following:

1. The Agency shall continue to comply with the Settlement Agreement in the Unfair Labor Practice proceeding. That agreement (Ag. Ex. 105) requires that the Agency grant Wonder Makers access to the facility to conduct such tests as Wonder Makers deems necessary to determine whether the facility is still encountering mold and/or moisture contamination, and that the Agency allow Wonder Makers to observe tests conducted by the Agency for it to make its determination whether the facility has mold or moisture infiltration problems.

2. The Agency shall continue to engage in air quality and other testing of the facility as provided in its final abatement plan. It shall provide copies of the test results to the Union or its designated agent.

3. The Agency shall restore all sick leave claimed on January 22, 2005 to all employees who were working in the facility at and before the time the facility was evacuated on January 22, 2005, and who took sick leave before the tower cab and TRACON were reopened on that day.

4. The Agency shall reimburse the Union for the expenses it incurred in removing mold contamination from the contents of the Union office located at the facility.

5. The Agency, in conjunction with the Union shall formulate a request to OPM for OPM to authorize hazardous duty pay for members of the bargaining unit who have worked in the facility between September, 2004 and the final acceptance of the mold remediation activities by the Joint Acceptance Inspection Board on February 13, 2007.

In all other respects, the grievances are DENIED.

ENTERED at Colorado Springs, Colorado, this 5th day of October, 2007.

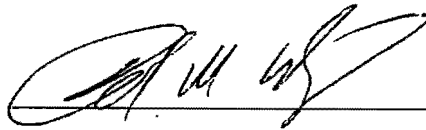

Daniel M. Winograd, arbitrator

1

4

**REPORT ON FAA'S ACTIONS TO ADDRESS
MOLD AT THE DETROIT METROPOLITAN AIR
TRAFFIC CONTROL TOWER FACILITY**

Federal Aviation Administration

Report Number: AV-2006-055

Date Issued: July 11, 2006



Memorandum

U.S. Department of
Transportation
Office of the Secretary
of Transportation
Office of Inspector General

Subject: ACTION: Report on FAA's Actions To Address
Mold at the Detroit Metropolitan Air Traffic
Control Tower Facility
Federal Aviation Administration
AV-2006-055

Date: July 11, 2006

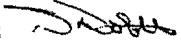
From: David A. Dobbs 
Assistant Inspector General
for Aviation and Special Program Audits

Reply to
Attn. of: JA-10

To: Federal Aviation Administrator

This report presents the results of our review of the Federal Aviation Administration's (FAA) actions to address mold at the Detroit Metropolitan Air Traffic Control Tower facility (the Facility). The review was initiated at the request of several members of the Michigan congressional delegation. Specifically, the Members expressed concerns regarding allegations that FAA was not properly addressing mold issues found at the Facility and that this was causing air traffic controllers to become ill. A copy of the congressional request is included at the Appendix to this report.

We conducted the review between February 2006 and May 2006. Our scope and methodology can be found at Exhibit A. Exhibit B lists the agencies we contacted or visited. We conducted this program audit in compliance with Generally Accepted Government Auditing Standards as prescribed by the Comptroller General of the United States.

Our objectives were to determine whether FAA has taken effective actions to remediate mold growth found at the Detroit Metropolitan Air Traffic Control facility and prevent similar incidents from occurring in the future. We met with staff from several of the requesting congressional offices in May 2006 to discuss our results. A copy of that briefing is attached at Exhibit C.

RESULTS IN BRIEF

FAA has taken actions to remove mold from the Facility but has not alleviated the source of moisture causing its growth. Until the moisture source has been controlled, mold will continue to be an ongoing problem. FAA is aware of this issue and advised us that projects to address moisture and humidity problems will begin in late July 2006 and are expected to be complete in November 2006. Those projects include sealing and caulking the exterior of the tower to eliminate water infiltration; additional replacement of interior wallboard; and further heating, ventilation, and air conditioning work to manage humidity.

Completing those projects on schedule is essential to fully remediate mold at the Facility. We are recommending that FAA provide the requesting Members of Congress with a list of the planned actions to complete mold remediation efforts and alleviate moisture infiltration at the Facility. We are also recommending that FAA include the expected completion date for each project.

BACKGROUND

Mold is a common fungus that may be detected visually or by odor. It grows best in warm, damp, or humid conditions but can survive in dry conditions. Whether mold is dead or alive, exposure to mold may cause symptoms such as nasal stuffiness, eye irritation, wheezing, or skin irritation in sensitive individuals. Persons with a compromised immune system are at an increased risk.

It is not necessary to identify the type of mold or conduct sampling as mold must be removed regardless of type. There are no Federal standards for airborne concentrations of mold or mold spores. Air sampling provides information that is valid only at the time the sample was taken, and results may be difficult to interpret. Remediation includes removing mold and alleviating the source of moisture. Until the source of moisture is controlled, remediation efforts are not complete.

The Facility is a 12-story tower connected to a 2-story base building with a basement that houses offices, locker rooms, a lunch room, and the Terminal Radar Approach Control (TRACON). The elevator shaft is located in the center of the tower and extends from the basement to the 12th floor. According to FAA, floors 3 to 10 were designed as unoccupied spaces and form the tower shaft. These areas are unconditioned (no mechanical heating or cooling) and should not be occupied or used for storage. There is no common ventilation ductwork from these areas to occupied areas.

At the time of our review, there were a total of 146 employees at the Facility—49 assigned to the tower, 62 assigned to the TRACON, and 35 assigned to the Technical Operations area.

FINDINGS

FAA Has Taken Actions To Remove Mold at the Detroit Metropolitan Air Traffic Control Tower but Remediation Will Not Be Complete Until Moisture Issues Have Been Addressed

Mold was initially found in unoccupied space on the fourth and ninth floors of the tower in September 2004. In January 2005, contractors hired by FAA removed the mold identified on those floors but found additional mold that was outside the scope of the contract. During the same month, mold was found in the elevator shaft. However, the mold found in the elevator shaft was not immediately dealt with because it was located on fire-rated drywall, which could not be removed in sections because of safety issues.

In May 2005, FAA let another contract to remove the mold found on the third, fourth, and ninth floors. In October 2005, FAA began monthly inspections at the Facility. During the November 2005 inspection, additional mold was found on the third floor (this mold was removed) and in the elevator shaft.

As a result, in February 2006, FAA hired a contractor to conduct an assessment of mold in the elevator shaft and to develop a scope of work for remediation. The report recommended that FAA remove the mold using a High Efficiency Particulate Air (HEPA) vacuum and wipe the areas down with a detergent and water solution. FAA completed those steps on May 26, 2006.

In June 2005, FAA also let another contract to identify probable causes of the excess moisture. The report, published in August 2005, identified the contributing factors for excess moisture as (1) water infiltration at concrete panel joints and concrete slab edges around the exterior of the building, (2) location and placement of interior wallboard panels, and (3) heating, ventilation, and air conditioning (HVAC) issues.

FAA officials at the Facility told us that contracts have been let to address each of the issues identified in the August 2005 report, and work is expected to begin at the end of July 2006 and be complete by November 2006. According to the FAA officials at the Facility, the late completion date is needed because the exterior caulking is an extensive project and can only be done during warm weather.

Several Employees Have Experienced Adverse Health Effects Related to Mold

Exposure to mold may cause symptoms such as nasal stuffiness, eye irritation, wheezing, or skin irritation in sensitive individuals. Persons with a compromised immune system are at an increased risk. Several employees at the Facility have experienced adverse health effects related to mold exposure. These factors highlight the need for FAA to aggressively pursue completion of its remediation efforts.

As of May 2006, 5 of the 49 employees who work at the tower had filed a health claim for workers' compensation with the Department of Labor (DOL)—2 of those employees have not returned to work. In March and April of 2006, DOL accepted three of those claims—two for asthma and one for exposure to mold. Of the two remaining claims, one was denied and one is still pending a DOL decision.

As of May 2006, 1 of the 62 employees who work in the adjoining TRACON had filed a health claim for workers' compensation, which is still pending a DOL decision. None of the 35 Technical Operations employees who work in the same building had filed for workers' compensation.

At the request of FAA and Facility employees, three independent Federal agencies conducted reviews at the Facility to determine if the level of mold presents a health hazard to employees.

- In November 2005, the Department of Health and Human Services, Centers for Disease Control, National Institute of Occupational Safety and Health (NIOSH) conducted a Health Hazard Evaluation of the Facility to determine if workers are exposed to hazardous materials or harmful conditions. The NIOSH review included an evaluation of medical records and a review of documents provided by FAA but did not include a site visit. In a verbal briefing to our office on the preliminary results, NIOSH officials stated that it is possible that mold exposure could have triggered some of the upper respiratory tract allergic-type symptoms that were reported by employees. However, NIOSH concluded that there is not enough mold present to pose a serious health hazard. As of July 2006, NIOSH had not issued a final report.
- In February 2006, the Department of Health and Human Services, Public Health Services, Federal Occupational Health (FOH) office conducted an on-site visual inspection of the Facility, including the elevator shaft, to evaluate FAA's remediation efforts and determine if the mold presented a serious health hazard. The FOH report stated that the air quality within the Facility is acceptable and that abatement activities conducted were performed properly and in a safe manner.

- In March 2006, at the request of Facility employees, DOL's Office of Safety and Health Administration (OSHA) conducted a site inspection at the Facility. On June 19, 2006, OSHA issued its final report, which recommended that FAA eliminate all sources of water intrusion into the Facility and maintain and operate outside air ventilation systems in accordance with design specifications to prevent infiltration of unconditioned air. OSHA also noted that individuals with underlying health conditions may be more sensitive to mold and encouraged individuals experiencing illness to seek appropriate medical attention.

RECOMMENDATION

We recommend that the FAA Administrator provide the requesting Members of Congress with a list of the planned actions to complete mold remediation efforts and alleviate moisture infiltration at the Facility and include the expected completion date for each project. We are also requesting that the FAA Administrator provide us with a copy of the information provided to the requesting Members.

AGENCY COMMENTS AND OFFICE OF INSPECTOR GENERAL RESPONSE

On May 18, 2006, we held an exit conference with the Air Traffic Manager at the Detroit Metropolitan Air Traffic Control Tower and the Area Director, FAA Technical Operations. Those officials agreed with our findings and recommendations.

ACTIONS REQUIRED

Please provide the above requested information within 15 business days.

We appreciate the cooperation and assistance provided by you and your staff during our review. If you have any questions or need further information, please contact me at (202) 366-0500 or Dan Ravielle, Program Director, at (202) 366-1405.

#

cc: FAA Deputy Administrator
ATO Chief Operating Officer
FAA Chief of Staff
Anthony Williams, ABU-100

EXHIBIT A. SCOPE AND METHODOLOGY

This review was conducted in accordance with Generally Accepted Government Auditing Standards prescribed by the Comptroller General of the United States and included such tests as we considered necessary to provide reasonable assurance of detecting abuse or illegal acts. We conducted this review between February 2006 and May 2006 using the scope and methodology described below.

To determine what actions FAA has taken to address mold at the Detroit Metropolitan Air Traffic Control Tower facility (the Facility), we toured the Facility on February 16, 2006, to observe the extent of remediation efforts. We reviewed documentation and reports provided by FAA. We also conducted interviews with FAA officials at the local (Detroit), district, regional, and service areas and with local, regional, and national representatives from the National Air Traffic Controllers Association (NATCA).

To determine the current status of air traffic controllers' health claims at the Facility, we conducted interviews with FAA representatives and with NATCA officials at the local, regional, and national levels. We also reviewed documentation provided by FAA and NATCA.

To obtain a better understanding of Federal guidelines, we conducted interviews with and reviewed documents provided by several independent Federal agencies, including the Environmental Protection Agency, Indoor Environments Division; the Occupational Safety and Health Administration; the U.S. Department of Health and Human Services, Centers for Disease Control, National Institute of Occupational Safety and Health; and Public Health Services, Federal Occupational Health (FOH).

We did not rely on automated databases as part of this audit.

EXHIBIT B. AGENCIES VISITED OR CONTACTED

- FAA Air Traffic Control—Detroit Metropolitan Air Traffic Control Tower
- FAA Technical Operations—Detroit Metropolitan Air Traffic Control Tower, Superior District Safety Management Office, and Central Service Area Headquarters
- National Air Traffic Controllers Association—Detroit Metropolitan Air Traffic Control Tower, Great Lakes Region, and Washington National Headquarters
- Environmental Protection Agency—Indoor Environments Division
- U.S. Department of Labor, Occupational Safety and Health Administration
- U.S. Department of Health and Human Services, Centers for Disease Control, National Institute of Occupational Safety and Health
- U.S. Department of Health and Human Services, Public Health Services, Federal Occupational Health (FOH)

EXHIBIT C. OIG BRIEFING TO CONGRESSIONAL STAFF

Review of FAA Actions To Address Mold at the Detroit Metropolitan Air Traffic Control Tower (DTW)

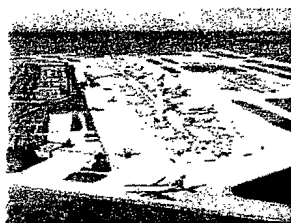

May 25, 2006
Project Number 06A3007A000

1

Objectives

The OIG received a letter dated January 9, 2006, from the following 6 Congressmen and 2 Senators:

| | |
|-------------------------------------|-------------------------|
| Congressman John D. Dingell | Senator Carl Levin |
| Congresswoman Carolyn C. Kilpatrick | Senator Debbie Stabenow |
| Congressman Sander Levin | |
| Congressman John Conyers, Jr. | |
| Congressman Joe Schwarz, M.D. | |
| Congressman Thaddeus G. McCotter | |

The OIG's objective was to respond to the following questions posed in the congressional letter:

- Has a proper and complete mold inspection and remediation been conducted at the facility, including direct sampling, air sampling, and physical intrusive inspecting?
- Has remediation occurred in the elevator shaft of the air traffic control tower?
- If remediation efforts have been concluded, why are air traffic controllers continuing to fall ill?

2

Methodology

- On February 16, 2006, we visited Detroit Metropolitan Air Traffic Control Tower (DTW). As part of our visit, we toured the facility to determine the extent of remediation efforts.
- We also conducted interviews with officials from the following organizations:
 - Environmental Protection Agency (EPA), Indoor Environments Division
 - Occupational Safety and Health Administration (OSHA), Lansing, Michigan
 - U.S. Department of Health and Human Services
 - Center for Disease Control (CDC), National Institute of Occupational Safety and Health (NIOSH)
 - Public Health Service (PHS), Federal Occupational Health (FOH)
 - U.S. Department of Transportation, Federal Aviation Administration (FAA)
 - Technical Operations – Detroit Metropolitan Air Traffic Control Tower, District Office, Great Lakes Region, and Central Service Area
 - Detroit Metropolitan Air Traffic Control Tower
 - National Air Traffic Controllers Association (NATCA) - Detroit Metropolitan Air Traffic Control Tower, Great Lakes Region, and Washington Headquarters
- We reviewed documentation and reports provided by FAA and the controllers' union, NATCA.

3

Results in Brief

Has a proper and complete mold inspection and remediation been conducted at the facility, including direct sampling, air sampling, and physical intrusive inspecting?

- Remediation has not been completed at DTW, as moisture issues have not been resolved.
- Mold found in unoccupied space on the third, fourth, and ninth floors and in the elevator shaft has been removed. Monthly inspections are being conducted to document the physical condition and identify any additional moisture or mold issues.
- *All projects to address identified moisture and humidity issues are planned for completion by late November 2006. This is the most important step FAA needs to complete to alleviate any future mold problems.*
- According to OSHA, NIOSH, CDC, and EPA, it is not necessary to identify the type of mold or conduct sampling as mold must be removed regardless of type. Furthermore, there are no Federal standards for airborne concentrations of mold or mold spores.

Has remediation occurred in the elevator shaft of the air traffic control tower?

- Remediation of mold identified in the elevator shaft was completed on May 25, 2006.

4

Results in Brief (continued)

If remediation efforts have been concluded, why are air traffic controllers continuing to fall ill?

As stated earlier, remediation efforts have not been completed. The following is the status of health claims at DTW as of May 25, 2006:

- 5 of 49 (10%) employees who work in the control tower at DTW have filed a workers' compensation claim with the Department of Labor — 3 of the 5 have returned to work.
- 1 of 62 (2%) employees who work in the adjoining Terminal Radar Approach Control facility (TRACON) has filed a workers' compensation claim with the Department of Labor.
- None of the 35 employees who work in Technical Operations at the tower have filed a workers' compensation claim.
- Of the six claims for workers' compensation, three were approved, one was denied, and two are pending.

5

Background: Mold Basics

OSHA, NIOSH, CDC, and EPA provided the following information regarding mold:

- Mold is a fungus that is found everywhere. It grows best in warm, damp, or humid conditions but can survive in dry conditions.
- Mold itself is not toxic or poisonous, though it can produce mycotoxins. Almost all of the known effects of mycotoxin exposures are attributable to ingestion of large amounts of contaminated food. No conclusive evidence exists to link exposure to indoor airborne mycotoxins with human illness.
- Whether mold is dead or alive, exposure to mold may cause symptoms such as nasal stuffiness, eye irritation, wheezing, or skin irritation in sensitive individuals. Persons with a compromised immune system are at an increased risk.
- Mold may be detected visually or by odor. It is not necessary to identify the type of mold or conduct sampling as mold must be removed regardless of type.
- Air sampling provides information only for the moment in time when the sample was taken, and results may be difficult to interpret. There are no Federal standards for airborne concentrations of mold or mold spores.
- Remediation is complete when the moisture source is identified/controlled and visible mold is removed.

6

Background: DTW Layout

- DTW is a 12-story tower connected to a 2-story base building with a basement. The elevator shaft is located in the center of the tower and extends from the basement to the 12th floor. Stairs are used to obtain access to the cab from the 12th floor.
- The first and second floors contain offices, a lunchroom, locker rooms, and the TRACON. A hallway connects the tower with the TRACON.
- According to FAA, floors 3 through 10 were designed as *unoccupied* spaces and form the tower shaft. These areas are unconditioned (no mechanical heating or cooling) and should not be occupied or used for storage. There is no common ventilation ductwork from these areas to occupied areas.
- Floors 11 and 12 are occupied and conditioned spaces.
- The tower cab, located above the 12th floor, is a conditioned space with an exterior catwalk.

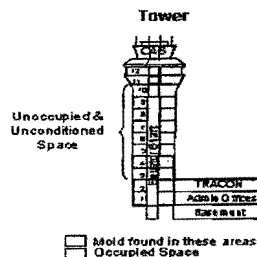

7

Is remediation of mold at DTW complete? What actions has FAA taken?

Remediation at DTW is *not* complete.

Mold was found in unoccupied space on the third, fourth, and ninth floors as well as on the walls of the elevator shaft. In order for remediation to be complete, moisture sources must be addressed and mold must be removed. FAA has taken actions to remove visible mold on the three floors and in the elevator shaft, but has not completed projects to address the source of moisture. Actions taken by FAA include:

- January 2005 - Limited areas of moldy gypsum wallboard were removed on the fourth and ninth floors. Additional mold was discovered and was not removed as it was not in the statement of work. This work was accomplished in the May 2005 remediation.
- May 2005 - Remediation was conducted on the 3rd, 4th, and 9th floors to include a total of 110 total square feet of wallboard material. This work included remediation of additional mold found during the January 2005 remediation. The photo at right depicts the ninth floor gypsum wallboard remediation work.
- June 2005 - A moisture assessment was conducted by an FAA contractor to identify probable causes of excess moisture. The Moisture Assessment Report stated that contributing factors to moisture issues may be location and placement of gypsum wallboard panels, water infiltration at concrete panel joints, and water penetration of the concrete slab edges.



8

Is remediation of mold at DTW complete? What actions has FAA taken? (continued)

- January 2006 – Remediation was conducted on the third floor in response to mold identified during the November monthly moisture inspection. The photo at right depicts this completed remediation that replaced the lower two feet of gypsum wallboard from the wall bordering the elevator shaft.
- February 2006 – In early February, a visual assessment of the control tower elevator shaft was conducted by FAA engineers, the Southwest Area Program Manager from Federal Occupational Health (FOH), and two independent Certified Industrial Hygienists contracted by the FAA. The purpose was to assess visible mold growth so that FAA could develop a scope of work for the elevator shaft remediation.
 - The FOH representative stated in the final report dated May 9, 2006, that DTW is “one of the cleanest FAA facilities FOH has inspected to date.” The report also stated that mold within the elevator shaft is minimal and HEPA vacuuming was recommended to remove it.

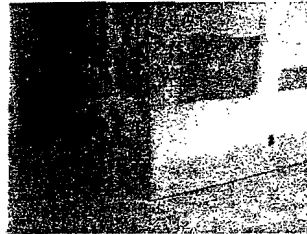

9

Is remediation of mold at DTW complete? What actions has FAA taken? (continued)

- The independent Certified Industrial Hygienist contracted by the FAA stated in a report dated March 10, 2006, that there were isolated patches of visible mold growth of three square feet or less on seven floors of the elevator shaft that could be removed by HEPA vacuuming and wipe-down.
 - In late February, the FAA engineering team conducted another on-site assessment of the tower to identify actions necessary to prevent water infiltration and moisture condensation. In response, the engineering team developed a schedule of projects targeted for completion by the end of November 2006.
- March 2006 – A team from OSHA conducted an on-site review of conditions at DTW in response to an employee complaint. The report of OSHA’s review has not yet been released.
 - May 2006 – Remediation of the elevator shaft was conducted by HEPA vacuuming and damp wipe-down with detergent and water.

10

What was the condition of the elevator shaft?

Several inspections of the elevator shaft have been conducted:

- June 2005 – An FAA contractor conducted a Moisture Assessment and reported that the visual inspection revealed minor surface mold growth on the interior shaft-liner at levels 6 through 9.
- February 2006 – Three parties (2 FAA contractors and an FOH official) inspected the elevator shaft. The official from the FOH's Public Health Service noted that there were small areas of visible mold in the elevator shaft that have not yet been remediated. One of the contractors reported that there were isolated patches of visible mold growth on the elevator shaft walls on seven various floors (3, 5, 6, 7, 8, 9, and 11) measuring less than three square feet.
- October 2006 – As part of monthly facility inspections led by an FAA Technical Operations Supervisor, a team rides in the cab of the elevator and inspects the interior of the elevator shaft by peering through a hatch in the roof of the elevator cab.
- May 2006 – Mold in the elevator shaft was remediated by HEPA vacuuming and damp wipe-down with detergent and water. FAA continues to conduct monthly moisture inspections of the facility (including the elevator shaft) to identify mold or moisture issues.

11

What did the mold in the elevator shaft look like?

- **Top Left:** Spots of visible mold growth on east wall of shaft of the third floor.
- **Top Right:** Visible mold growth on shaft on west wall of seventh floor.
- **Bottom Left:** Visible mold growth on shaft on west wall of eighth floor.
- **Bottom Right:** Visible mold growth on east wall of shaft of sixth floor.

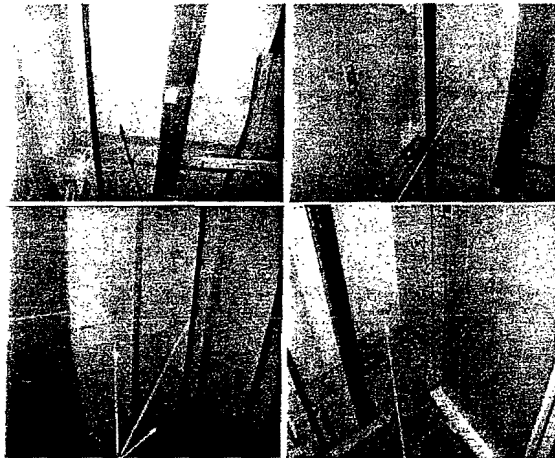

12

What additional actions are planned by FAA to address mold and moisture issues at DTW?

Mold identified at DTW has been removed, but projects to address moisture and humidity issues have not been completed. The facility conducts monthly moisture inspections to identify mold or moisture issues. The FAA has planned several projects to address moisture and humidity issues. These are the key steps FAA needs to complete so that water infiltration does not reoccur:

- July - October 2006 - Exterior sealing and caulking to eliminate water infiltration.
- August - September 2006 - Interior work that may include removal of walls/wallboard and changes to accommodate HVAC duct modifications if needed.
- August - November 2006 - Mechanical/electrical work including HVAC (Heating/Ventilation/Air Conditioning) work to control and manage humidity within the tower and elevator shafts.

Pictured:
Near right - Exterior caulking failure.
Far right - Moisture seeping into unoccupied space in the tower from the exterior wall.

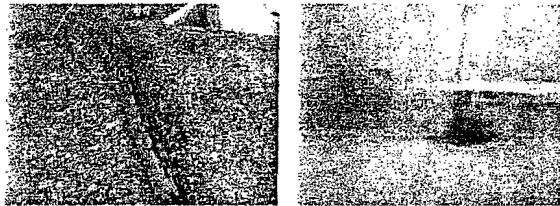

13

What is the status of the health of employees working at DTW?

As noted in the chart below, as of May 25, 2006, 5 of the 49 employees who work in the control tower have filed a health claim for workers' compensation (2 of whom have not returned to work), 1 of the 62 employees who work in the TRACON have filed a health claim for workers' compensation, and none of the 35 Technical Operations employees who work in the building have filed for workers' compensation.

*DTW/TRACON/Technical Operations Statistics
(As of May 25, 2006)*

| Workgroup | Employees* | Filed Workers' Compensation | Have Not Returned to Work |
|------------------|------------|-----------------------------|---------------------------|
| DTW | 49 | 5 (10%) | 2 (4%) |
| Detroit TRACON | 62 | 1 (2%) | 1 (2%) |
| Detroit Tech Ops | 35 | 0 (0%) | 0 (0%) |
| Total | 146 | 6 (4%) | 3 (2%) |

*excludes administrative staff

14

What is the status of the health of employees working at DTW? (continued)

The following tables provide additional details on the five employees at the tower and one employee at the TRACON who filed for workers' compensation:

| Tower Controller | Date Claim Filed | Dates Controller Was Out of Work | Did the Department of Labor Accept the Claim? |
|------------------|--------------------|---------------------------------------|---|
| #1 | September 30, 2005 | October 1, 2005 to present | Yes, for Asthma, March 28, 2006 |
| #2 | September 27, 2005 | October 1, 2005 to November 12, 2005 | Yes, for Asthma, April 18, 2006 |
| #3 | September 8, 2005 | July 26, 2005 to present | Yes, for Exposure to Mold, April 14, 2006 |
| #4 | December 29, 2005 | December 14, 2005 to January 31, 2006 | No, Denied |
| #5 | January 17, 2006 | December 19, 2005 to January 29, 2006 | Pending |

| TRACON Controller | Date Claim Filed | Dates Controller Was Out of Work | Did the Department of Labor Accept the Claim? |
|-------------------|------------------|----------------------------------|---|
| #1 | April 26, 2006 | February 19, 2006 to present | Pending |

15

Does mold pose a serious health hazard at DTW?

According to officials at two Federal agencies, conditions at DTW do not pose a serious health hazard to employees:

- November 2005** — NIOSH began conducting a Health Hazard Evaluation of DTW, including a review of medical records. The medical doctor on the NIOSH team stated that it is possible that mold exposure could have triggered some of the upper respiratory tract allergic-type symptoms that were reported by controllers but stated that the claims of actual occupational illness or disease due to mold exposure are not supported by the conditions at the tower. NIOSH concluded that there is not enough mold present to pose a serious health hazard.
- February 2006** — FOH conducted a health assessment of the tower and stated that there is not enough mold to produce an affect on someone's health unless the person has a compromised immune system or allergic sensitivity to mold. FOH stated that the only mold at DTW was a small amount of dry mold in the elevator shaft.
- March 2006** — OSHA conducted a site inspection although the elevator shaft could not be observed because it could not be taken out of service at the time of the OSHA inspection. As of May 25, 2006, OSHA has not released a final report of its assessment to determine if the level of mold at DTW presents a serious health hazard.

16

Conclusions

As of May 25, 2006:

- Remediation is not complete at Detroit Metropolitan Air Traffic Control tower because moisture infiltration and humidity issues have not been corrected.
- All projects planned to eliminate the moisture are estimated to be completed by the end of November 2006.
- Of the 49 employees working in the tower at DTW, 5 have filed workers' compensation claims with the Department of Labor, of which 3 have been accepted; 1 has been denied; and 1 is pending. Two of the 5 employees who filed workers' compensation claims remain out of work.
- Of the 62 employees working in the TRACON adjoining DTW, 1 has filed a workers' compensation claim with the Department of Labor. The claim is pending.
- None of the 35 Technical Operations employees have filed a workers' compensation claim.

APPENDIX. CONGRESSIONAL REQUEST LETTER TO OIG

Congress of the United States
Washington, DC 20515

January 9, 2006

Kenneth M. Meade, Inspector General
United States Department of Transportation
400 7th Street S.W. Room 9210
Washington, D.C. 20590

Dear Inspector General Meade:

We write with great concern to a serious issue occurring at the Detroit Metropolitan Airport's air traffic control tower. Over the last year, air traffic controllers have been getting sick while on the job. Many of these illnesses are attributed to black mold that has been found within the tower itself.

We have written two letters to the Federal Aviation Administration (FAA) regarding this issue, and while we are told by the FAA remediation efforts have been conducted, we continue receiving calls from our constituents that work in the tower that they are getting sick when they enter the tower. Two of the more severe health cases amongst the air traffic controllers leave them on a leave without pay status, pending their Office of Workers' Compensation Programs (OWCP) claim, due to the effects of their illnesses. Numerous others have been utilizing excessive sick leave due to mold related symptoms or illnesses.

We are also informed by the National Air Traffic Controllers Association (NATCA) that their efforts to work with FAA officials to solve the problem have been met with a reluctant and inadequate effort to alleviate the black mold problem. We believe that the Inspector General should investigate the black mold remediation process at Detroit Metropolitan Airport. Specifically, the Inspector General should examine the following questions:

1. If remediation efforts have been concluded, why are air traffic controllers continuing to fall ill? Has a proper and complete mold inspection and remediation been conducted at the facility, including direct sampling, air sampling, physical intrusive inspecting?
2. Has remediation occurred in the elevator shaft of the air traffic control tower?

For over a year, this has been a serious issue at Detroit Metropolitan Airport, and yet some of our constituents are still getting ill when they enter the air traffic control tower. It is important that those who work at the tower know that the black mold has been remediated properly. It is equally important that the flying public know that the air traffic controllers who help guide them into Detroit Metro know that they are healthy and able to do their jobs safely and effectively.

Sincerely,

John D. Dingell
Member of Congress

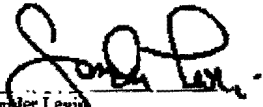

Carolyn E. Kilpatrick
Member of Congress

PRINTED ON RECYCLED PAPER

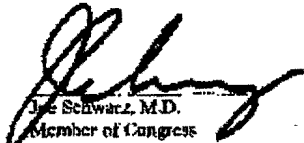

Samir Levin
Member of Congress

Jim Conyers, Jr.
Member of Congress

Carl Levin
U.S. Senator

Joe Schwarz, M.D.
Member of Congress

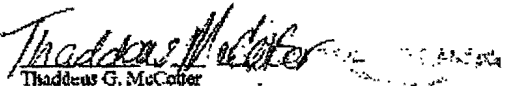
Debbie Staben
U.S. Senator

Thaddeus G. McCotter
Member of Congress

1

5

U.S. Department of Labor
Occupational Safety and Health Administration
315 W. Allegan Street, Room 207
Lansing, Michigan 48933
(517) 487-4996
FAX (517) 487-4997



June 19, 2006

Joseph Figliuolo
Air Traffic Manager
Federal Aviation Administration
Detroit Metropolitan Airport
Building 801, Room 104
Detroit, MI 48242

Dear Mr. Figliuolo:

As you know, an inspection of your workplace, located at Detroit Metropolitan Airport, Detroit, Michigan by representatives of the Occupational Safety and Health Administration (OSHA) was completed on March 21, 2006. The inspection addressed the allegation of employee exposure to mold in the Detroit Metropolitan Airport Air Traffic Control Tower (Control Tower).

The situation involving mold in the Control Tower has been an ongoing concern since prior to January 2005 when remediation efforts were undertaken by the Federal Aviation Administration (FAA). No sampling for mold was done by OSHA because there was no visible evidence of the presence of mold in the occupied spaces of the Control Tower. As a general rule, sampling for molds and other bioaerosols is not done. There are currently no governmental or professional recommendations for airborne concentrations of mold, mold spores, mycotoxins, and other bioaerosols with which to compare sampling results and sampling for mold, mold spores, mycotoxins, and other bioaerosols is not part of a routine building evaluation.

It should be remembered that we are all exposed to mold spores in the air we breathe on a daily basis, both indoors and outdoors. Molds can grow on just about any organic substance, as long as moisture and oxygen are available. Mold growth may occur when excessive moisture accumulates in buildings or on building materials including carpet, ceiling tile, insulation, paper, wallboard, wood, surfaces behind wallpaper, or in heating, ventilation and air conditioning systems. It is impossible to remove all molds and mold spores in the indoor environment. The key to mold prevention is moisture control and adequate ventilation.

I understand that a number of individuals who work in the Control Tower have complained of various illnesses which may be related to their working environment. Most people experience no health effects from exposure to the molds present in indoor or outdoor air. However, molds and their metabolic by-products have been associated with adverse health effects. Building related illnesses (BRIs) are diagnosed by evaluation of signs and symptoms by physicians or other licensed health care professionals. The health effects from exposure to mold contamination in an indoor environment can be common allergic BRIs such as allergic rhinitis, allergic asthma, and hypersensitivity pneumonitis and other infections. Some individuals with underlying health conditions may be more sensitive to molds. We would encourage any individuals experiencing illnesses to continue to seek appropriate medical attention.

OBSERVATIONS AND RECOMMENDATIONS

The facility has experienced water intrusion problems for several years from various sources such as leaking pipes/valves, a blocked drain, roof leaks, possible high humidity in the elevator shaft, condensation, and malfunctioning ventilation resulting in water leaks, possible water infiltration through the pre-cast concrete panel joints and possible water penetration at concrete slab edges.

The key to mold prevention is moisture control. The most important initial step in prevention is a visual inspection. Regular checks of the building envelope and drainage systems should be made to assure that they are in working order. Identify and, to the extent possible, eliminate sources of dampness, high humidity, and moisture to prevent mold growth. Wet or damp spots and wet, non-moldy materials should be cleaned and dried as soon as possible (preferably within 24 to 48 hours of discovery).

The outside air ventilation system serving the cab was disabled to prevent mechanical problems associated with freezing coils. Staff indicated that the dampers to the unit were shut about ten years ago because a chilled water coil had "frozen." Section 8.4.1.2 of the ANSI/ASHRAE Standard 62.1-2004 (Ventilation for Acceptable Indoor Air Quality) recommends that every three months the outside air dampers and actuators be visually inspected or remotely monitored to verify that they are functioning. Section 8.1.2 of the ANSI/ASHRAE standard recommends that the ventilation systems be operated with at least 17 cubic feet per minute (cfm) per person of outside air introduced into the workspace whenever it is occupied. There was no outside air coming into the facility from air handling unit number 14 which was providing conditioned air to the "cab" on the day of the OSHA site visit. It is necessary to bring in more outside air to the "cab" than is exhausted in order to keep the "cab" under positive pressure compared to surrounding environments. The original design for the Control Tower called for a minimum of 500 cfm of outside air. The result of not providing make-up air is that any contaminant released in the Terminal or Tower would not be diluted and removed by ventilation with outside air and it would be difficult to keep the "cab" under positive pressure as required by the Control Tower Design Specifications.

The smoke trail evaluation indicated the base of the Control Tower is negatively pressurized compared to the outside and to the Terminal. This is significant because this infiltrating air feeds the "stack effect" in the Tower. Stack effect is the ventilation in buildings that results from thermal differences between indoor and outdoor temperature. The greater the thermal difference and the height of the structure, the greater the stack effect. Consequently, any contaminant released in the Tower or Terminal would end up in the "cab".

Recommendations:

- Eliminate all sources of water intrusion into the facility. Mold can grow wherever there is dampness. Damp or wet building materials and furnishings should be cleaned and dried within 24 to 48 hours to prevent the growth of mold.
- Maintain and operate the outside air ventilation system in accordance with design specifications. Provide 500 cfm of outside air to the "cab" and keep the "cab" under positive pressure through proper maintenance and operation of air handler numbers 13 and 14. Operate air handlers numbers 1 thru 4 serving the first two floors such that the first two floors of the facility are under positive pressure compared to the outside and to the Terminal. All HVAC systems should be operated to keep the facility under positive pressure to prevent infiltration of unconditioned air. Pressurizing the lower floors will help minimize the "stack effect" in the elevator shaft and middle tower area.

DTW AIRWAYS FAC

I have enclosed for your information a list of observations and technical recommendations which will be helpful for the continued control of mold and the improvement of the ventilation system your facility. Many of these recommendations are based on guidelines developed by various scientific or regulatory organizations and should be followed as closely as possible.

I would appreciate your review of this information and would like to receive a report from you within 60 days to address your progress towards implementing these recommendations. If you have any questions, or if OSHA can be of further assistance to you, please feel free to contact my office.

Sincerely,

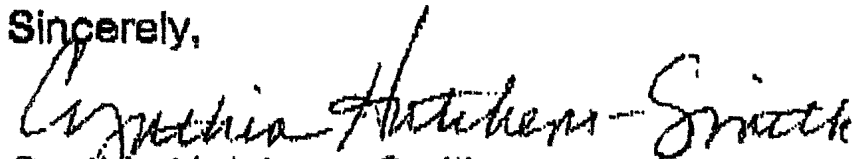

Cynthia Hutchens-Smith
Area Director

Enclosure

16



Federal Aviation Administration

Memorandum

Date: SEP 17 2008

To: Linda Washington, Assistant Secretary for Administration, Designated Agency Safety and Health Official

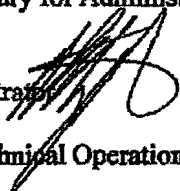
From: Robert A. Sturgell, Acting Administrator 

Prepared by: Steve Zaidman, Vice President, Technical Operations Services

Subject: Whistleblower Investigation – Allegations of Mold and Moisture Problems at Detroit Metropolitan Airport

Thank you for providing us your report on the Investigation of Mold and Moisture at the Federal Aviation Administration (FAA) Detroit Metropolitan Air Traffic Control Tower (DTW) Facility dated August 21, 2008.

Since discovery of mold at DTW in 2004, the FAA has diligently pursued the remediation of mold and elimination of water intrusion at the tower and base building to ensure that both facilities provide a safe and healthful workplace for our employees. To date, the FAA has expended in excess of \$1 million for remediation and modification efforts and approximately 45 personnel (FAA and contractor) have had some level of involvement.

Based on the corrective actions that the FAA has taken at these facilities, and the sampling and testing, which have been conducted by FAA and independent third parties, we strongly believe that both facilities provide a safe and healthful work environment for our employees. We hope that by accepting all your recommendations, this will further demonstrate FAA's commitment to ensure that DTW and the base building contain no health hazards for our employees. The recommendations and FAA's plans to implement them are included in attachment 1.

We note that your investigation did not find any indicators of poor indoor air quality and did not detect elevated mold spore concentration. In fact, indoor concentrations were consistently lower than outdoor concentrations.

Finally, although we plan to implement your recommendations, our review of the report disclosed information that we believe is inaccurate or misleading and does not correctly identify the existing conditions or the efforts that FAA has taken to protect its employees. This information is detailed in attachment 2 to this memorandum. We highly recommend you consider making the appropriate adjustments to your report. The FAA remains dedicated to providing a safe and healthful work environment for all its employees.

Attachments

Attachment 1

FAA Action Plan to Accomplish Recommendations Contained in
OST DTW Mold Investigation Report Dated August 21, 2008

Air Traffic Control Tower Mold/Moisture Recommendations

A. OST Recommendation (ATCT): Conduct a comprehensive inspection of the wall cavities on every floor of the air traffic control tower, making sure to inspect the wall cavity from the unoccupied room side of the elevator shaft.

FAA Response: The FAA will retain a Certified Industrial Hygienist experienced with mold and indoor air quality issues to complete the recommended action. **Action:** Project completion date is December 31, 2008.

B. OST Recommendation (ATCT): Based on the comprehensive inspection, remove all visibly contaminated (molded and water damaged porous materials) from the air traffic control tower.

FAA Response: The FAA will develop and implement projects to remove molded and water damaged porous materials identified from the inspection. **Action:** Design and engineering will begin immediately upon completion of the inspection with contract work following as soon as possible.

C. OST Recommendation (ATCT): Develop a mold remediation project communication plan for the facility to improve communication efforts between FAA management and union employees.

FAA Response: The FAA will develop a plan to improve communication. **Action:** Project communication plan implementation date is October 1, 2008.

D. OST Recommendation (ATCT): Remove all unnecessary wallboard and carpeting from unoccupied areas of the air traffic control tower and remove any wallboard currently in contact with concrete floors.

FAA Response: The FAA will assess which wallboard and carpeting is not needed in the unoccupied areas of the ATCT. A project will be developed to remove these items. **Action:** This effort will be included in the work to be accomplished under Recommendation B.

E. OST Recommendation (ATCT): Evaluate the fire rating of cement backer board and mold resistant/paperless wallboard.

FAA Response: The FAA will evaluate wallboard that needs to be replaced in the ATCT and attempt to substitute with fire-rated, mold-resistant products. When the wallboard is replaced, a gap will be left between the concrete floor slab and new wallboard to prevent wicking of moisture into the panel. **Action:** This effort will be included in the work to be accomplished under Recommendation B.

F. OST Recommendation (ATCT): Continue efforts to prevent moisture intrusion into the air traffic control tower and prevent condensation from forming.

FAA Response: The FAA will continue to prevent water intrusion and condensation issues in the ATCT. Comments and recommendations were submitted to the OST indicating that the corrective measures identified were completed and controlling the ATCT moisture issues. Further preventative measures such as gaps between the drywall and the concrete slab floors, removal of unnecessary wallboard and carpeting, and monitoring the environmental conditions (i.e., with sensors) in various areas will be pursued by FAA. **Action:** Monitoring is on-going; other items will be accomplished under Recommendation B.

G. OST Recommendation (ATCT): Actively monitor moisture in the elevator shaft and unoccupied areas of the air traffic control tower and implement corrective actions as necessary.

FAA Response: The monitoring is currently in progress. To date, there are no indications of excessive moisture and/or humidity. **Action:** The monitoring is on-going and will be documented for historical recordkeeping.

H. OST Recommendation (ATCT): Review the policies at FAA's Detroit Air Traffic Control Tower to ensure that employees are encouraged to report work-related health and medical problems.

FAA Response: The FAA will review such policies. **Action:** Policy will be reviewed and made available to all facility personnel on-site by October 1, 2008.

L. OST Recommendation (ATCT): Evaluate other FAA air traffic control towers for mold and moisture infiltration problems. The Detroit Metropolitan Airport air traffic control tower is of a Leo Daly design. FAA operates other Leo Daly designed towers of similar construction and characteristics. It is prudent for FAA to inspect these other towers to determine if similar mold and moisture problems exist at those facilities.

FAA Response: The DTW ATCT is a Leo Daly designed tower. The FAA will inspect Leo Daly designed towers throughout the country to determine if mold and moisture problems exist at these facilities. **Action:** The inspection of all Leo Daly towers will be completed by December 31, 2008.

Base Building Roof Moisture Recommendations

J. OST Recommendation (Base Building): Replace the leaking base building roof.

FAA Response: **Action:** Prior to the Department's investigation, the FAA had plans to replace the roof. At the Department's request, those plans were placed on hold pending the conclusion of the investigation. A new roofing membrane will be installed by March 30, 2009.

K. OST Recommendation (Base Building): Continue to immediately remove and replace water damaged building materials as necessary.

FAA Response: The FAA will continue to remove and replace such items. When such incidents arise, an investigation shall be made to identify the moisture source and correct it. **Action:** Issues should not continue after roof replacement under Recommendation J.

I. OST Recommendation (Base Building): Develop a roof project communication plan for the facility to improve communication efforts between FAA management and union employees.

FAA Response: Local FAA management will develop a communication plan to educate employees about the roof project and the control efforts being implemented to ensure a safe working environment. **Action:** Roof replacement efforts, including scope specifics and work hours, will be coordinated with facility management and employees in the accomplishment of Recommendation J by October 1, 2008.

Attachment 2

FAA Comments on OST DTW Mold Investigation Report Dated August 21, 2008

These comments are based on a thorough review of the report. We believe these comments are significant from the standpoint of ensuring the accuracy and completeness of the final report. We recommend that you review this information and revise the report accordingly.

1. Page 3, Executive Summary - 3rd and 4th bullets: The report states that FAA employees attributed a variety of symptoms to their exposure to mold and moisture at the Detroit Tower and that NIOSH's medical review failed to establish a link between the mold/ moisture and many of the symptoms.

The July 24, 2006 NIOSH report summarizing their Health Hazard Evaluation includes a medical review on pages 4-5. After reviewing the written symptoms profile and medical records provided by the employees, NIOSH concluded that:

- They could not find an association between Detroit Tower moisture/mold issues and the development of asthma in individuals without previous asthma;
- They could not find an association between the Detroit Tower moisture issues and the development of Chlamydiae pneumonia; and
- Citing research conducted by the Institute of Medicine of the National Academies, the evidence of an association between damp indoor environments or exposure to moldy environments and skin symptoms, mucous membrane irritation syndrome, lower respiratory illness in otherwise healthy adults, fatigue, neuropsychiatric symptoms, and immune diseases is either inadequate or insufficient.

In the interest of completeness and accuracy, we believe the following would be more appropriate wording for your report:

As part of a Health Hazard Evaluation, NIOSH conducted a medical review. They reviewed the written symptoms profile and medical records provided by site employees. They were unable to find an association between the Detroit Tower moisture/mold issues and many of the symptoms experienced by the employees.

2. Page 5, 3rd paragraph, 2nd sentence and page 8, 1st paragraph after bullets, 2nd sentence - You state that the FAA was advised to clean visible mold from the elevator shaft liner using a biocide chemical. The FAA took a conservative approach and did not use a biocide. We used a deodorizer called Dri-Eaz Milgo SR. It is not marketed or approved by the EPA as a biocide. It is primarily used as a spray to deodorize residential carpets by carpet cleaners and is suitable for use as a residential laundry aid. The only hazardous ingredient listed in the MSDS is isopropyl alcohol (3-6 percent). The manufacturer recommends the addition of 8 ounces per gallon for wall applications.

The FAA contractor added approximately 2 ounces per gallon. Once this dilution was completed, there was less than 0.5 percent alcohol in the liquid being sprayed. Common isopropyl alcohol in first aid kits is used at 70 percent strength.

3. Page 8, Footnote - The footnote refers to a Dr. Richard's Shoemaker. It is our understanding that this is the same "Dr. Ritchie Shoemaker" referred to in the court findings that follow: On July 22, 2008, the U.S District Court for the District of Columbia ruled in the case of Young and Ghee v. Burton and Lewis & Tompkins. The lawsuit sought recovery for damages suffered by plaintiffs as result of exposure to toxic mold while residing at the Stanton Glen Apartment (page 1). The judge dismissed the charges for the following reason:

"Based on the record herein, including testimony presented at a Daubert hearing, the Court concludes that Dr. Shoemaker's diagnosis of plaintiffs, as well as his opinions relating to general and specific causation are not sufficiently grounded in scientifically valid principles and methods...(pages 1-2)."

According to Page 15 of the same document, Dr. Shoemaker's:

"testimony has been excluded in a number of jurisdictions, including Virginia, Florida, and Alabama... A D.C. superior court judge excluded Dr. Shoemaker's testimony because neither his theory on the effects of indoor mold exposure nor his methodology in diagnosing the plaintiffs with chronic biotoxin- associated illness (CBAI) was generally accepted within the scientific community." Wright v. Fort Lincoln Realty Co., et al, No. o3ca4555, at 2-4 (D.C. Sup. Ct. Oct 15, 2007).

While we did commission the inspection, we now believe Dr. Shoemaker's methodology and work to be unreliable.

Thank you for the opportunity to provide these clarifications. I hope the information is useful in preparing your report.

1

7

DRAFT

DTW Project Communication Plan

September 25, 2008

The purpose of this communication plan is to ensure that project information is effectively communicated between managers, employees, Environmental and Occupational Safety and Health (EOSH) professionals, project Resident Engineer (RE) and site contractors. This plan specifically addresses projects associated with mold remediation, roof repair, and other efforts to address water intrusion and/or condensation.

1. Prior to Project Commencement

- a. Pre-Construction Meeting: Local management shall hold a Pre-Construction meeting prior to the start of each project. The meeting shall include the project RE, an EOSH professional, contractor(s) representatives, contracting officer, local management, and shall be made open to union (NATCA/PASS) attendance. The topics that shall be covered include the: 1) scope of work, 2) location(s), 3) project schedule, 4) potential hazards, including a review of the completed risk assessment plan, 5) controls to be used, 6) sampling plan (if applicable), 6) communication of project status and data to employees, 7) pre-construction checklist, 8) potential impacts to employees, 9) applicable Material Safety Data Sheets (MSDSs), 10) contingency plans, and 11) applicable background and historical information pertaining to project. A question and answer session shall take place afterwards. If necessary, a walkthrough of the affected areas may be conducted to further clarify the project scope.
- b. Memorandum to Employees: Each employee will be notified of an upcoming project via memorandum from local management. The memorandum shall address the following: 1) scope of work, 2) locations(s), 3) project schedule, 4) potential hazards, and 5) location where project information will be posted. The project RE and/or EOSH professional will assist local management in drafting the memorandum to ensure the appropriate information is captured in the document.
- c. Pre-Construction Checklist: In accordance with FAA order 3900.57, an FAA Preconstruction and Maintenance Project Safety and Health Checklist shall be completed prior to the start of the project. Please refer to the attached document. The purpose of the checklist is to identify potential safety and environmental hazards that may impact facility employees and the National Airspace System (NAS).

- d. MSDSs: The contractor shall provide all MSDSs to the project RE. The MSDSs will be reviewed during the pre-construction meeting and be made available to employees for their review.

2. During the Project

During the project, the RE shall maintain communication with the EOSH professional and local management. In the event that NAS operations may be adversely impacted by the project, the RE shall immediately notify local management.

After each shift, the contractor and/or RE shall provide a written briefing to local management to include the following: 1) summary of work accomplished, 2) upcoming schedule (e.g., next shift), 3) monitoring results, and 4) significant changes to the project. Local management will post these briefings in a designated location for employees to review. Local management shall host daily or periodic meetings to further communicate the project status and upcoming events.

Employees may contact their supervisor if any questions or concerns arise before or during the project. Supervisors will then forward those questions to the DTW Terminal Manager/DTW GNAS Manager. If requested, the RE and/or EOSH professional will provide input to the Terminal/GNAS managers.

3. Project Completion

The RE will notify the EOSH professional, contracting officer, and local management when the project is completed. This information will be communicated from local management to the employees. Local management shall notify employees when the project is completed.

1

8

APPENDIX D: INDUSTRIAL HYGIENE REPORT

June 9, 2008

Mr. Thomas Black
Department of Transportation
1201 New Jersey Avenue, SE
Room W58-303
Washington, DC 20590

Dear Mr. Black:

On May 19 and 20, 2008, M. A. Cecil and Associates, Inc. conducted an inspection in the Detroit Metropolitan Airport Traffic Control Tower.

In accordance with the scope of work, the goal for this inspection was to determine if mold colonization was present in the control tower and to conduct bioaerosol air sampling in the control tower and base building. The following parameters were evaluated: bioaerosol (fungi and environmental bacteria), fungal spores, airborne particulate, carbon dioxide, carbon monoxide, temperature, and relative humidity.

The enclosed report includes the results of the sampling, discussion of the results and recommendations. If you have any questions or require additional information, please contact me at (301) 855-7710.

Sincerely,

Michael A. Cecil, CIH

Enclosure

INDOOR AIR QUALITY SURVEY
at the
DETROIT METROPOLITAN AIRPORT
AIR TRAFFIC CONTROL TOWER
Detroit, Michigan

Prepared for:

MR. TOM BLACK
DEPARTMENT OF TRANSPORTATION
1201 NEW JERSEY AVENUE, SE
ROOM W58-303
WASHINGTON, DC 20590

M. A. CECIL & ASSOCIATES, INC
4475 SHANNON WAY
PORT REPUBLIC, MARYLAND

May 2008

EXECUTIVE SUMMARY

M. A. Cecil and Associates, Inc. conducted an inspection in the Detroit Metropolitan Airport Traffic Control Tower. The inspection was conducted on May 19 and 20, 2008. The scope of work included an inspection of the control tower elevator shaft to determine if mold colonization was present and to conduct bioaerosol sampling in the control tower and base building. The goal was to determine if further mold remediation was required and evaluate the likelihood of employees being exposed to mold. A visual inspection (non invasive) of the elevator shaft was conducted followed by an invasive inspection of several locations within the tower.

The inspection of wall cavities on the fourth and ninth floors revealed that apparent mold growth is present in the ATCT. The location of the apparent mold growth observed and the previously abated contaminated drywall was likely caused by water intrusion. Based on the Jacobs Engineering inspection report water/moisture was able to enter the tower shaft at joints in the pre-cast concrete panels where deteriorated caulking and backer rod was unable to prevent moisture intrusion. The likely scenario is that water pooled on a given level's concrete floor and through wicking action was taken into the drywall thus allowing mold colonization. Furthermore, it is likely that the introduction of moisture laden air into the tower environment caused condensation to occur and further add moisture to the drywall. The surface mold previously observed and subsequently removed from the elevator shaft liner could have been due to condensation and/or poor moisture/temperature control of the elevator shaft environment.

Several corrective actions have been completed in the ATCT. Mold contaminated drywall was removed from several unoccupied levels of the tower. The exterior surface of the ATCT and base building were sealed with a moisture resistant sealant. Deteriorated caulking and backer rod was removed from pre-cast joints and replaced. Heaters have been installed and ventilation system modifications have been completed in an effort to control and or prevent condensation in the ATCT and moisture and temperature sensors were installed to monitor conditions in the elevator shaft and unoccupied tower levels. Also, cab roof leaks were sealed.

Based on the corrective actions completed thus far, the bioaerosol sampling results obtained during this survey, and the location of apparent mold growth it is suspected that FAA employees are not exposed to significant bioaerosol concentrations. Apparent mold growth was not noted on outward surfaces of drywall in the elevator shaft or on unoccupied level walls. The identified apparent mold growth was located between layers of intact drywall and in unoccupied areas. The unoccupied areas are not serviced by existing ventilation systems currently servicing occupied levels of the tower and totally independent from the base building ventilation systems. The only connection would be the air moved through the piston action of the elevator car in the elevator shaft which contains relief vents allowing air to be discharged at the top and bottom of the shaft.

Based on the sampling results and observations the following recommendations are offered.

- Perform comprehensive inspection of the elevator shaft drywall liner to identify mold contamination. Remove any porous material, such as drywall, which is visibly contaminated with mold or stained. Do not attempt to clean porous materials. Clean

remaining substrates, and replace building materials as necessary. The remediation must be conducted in a similar manner as asbestos abatement and as previously performed on the third, fourth, and ninth unoccupied levels of the ATCT.

- Proceed with the base building roof replacement. The roof must be replaced as it is the major source of water intrusion remaining. Ensure adequate control measures are in place and implemented to prevent infiltration of airborne volatile organic compounds likely to be generated from the roof replacement process. Consideration should be given to conducting the roof replacement during night hours.
- Remove drywall from unoccupied levels of the ATCT other than drywall necessary to maintain the required fire rating. If it is necessary to install drywall on unoccupied levels of the ATCT; replace drywall currently in contact with concrete floors with drywall installed with at least a one half inch gap or provide a strip of silicone caulking at the concrete/drywall junction to prevent condensation and/or moisture intrusion from wicking into the drywall.
- Alternatively, evaluate the fire rating for cement or backer board or mold resistant drywall now commercially available to be used as a substitute material for the removed drywall. Install a two foot high strip (from the floor) of a substitute material for walls located on unoccupied tower levels.
- Remove and discard the existing carpet in the former union office located in the tower.
- Monitor temperature and moisture levels in the elevator shaft and unoccupied levels and implement corrective actions as necessary to prevent condensation on surface materials.
- Continue to inspect the ATCT on a regular basis and remove and replace water damaged building materials as necessary.

INTRODUCTION

M. A. Cecil and Associates, Inc. conducted an inspection in the Detroit Metropolitan Airport Traffic Control Tower. The inspection was conducted on May 19 and 20, 2008. The scope of work included an inspection of the control tower elevator shaft to determine if mold colonization was present and to conduct bioaerosol sampling in the control tower and base building. The goal was to determine if further mold remediation was required and evaluate the likelihood of employees being exposed to mold. A visual inspection (non invasive) of the elevator shaft was conducted followed by an invasive inspection of several locations within the tower. To date, various entities have reported that only surface mold had been present on the elevator shaft lining and no invasive inspections were completed. In addition to the inspection numerous inspection reports were reviewed concerning past conditions, mold remediation, and recommendations to control moisture intrusion into the tower.

BACKGROUND

The Detroit Metropolitan Airport Air Traffic Control Tower (ATCT) is approximately 230 feet tall attached to a two story base building. Generally, the tower is constructed of concrete and steel. The two upper levels of the tower, cab and junction levels are occupied. The remaining levels 10 through 2 are unoccupied. Interior walls (perimeter) of the unoccupied levels are gypsum wall board on metal stud wall systems. The elevator shaft (central to the tower) is constructed with four layers of gypsum wallboard; the inner shaft is lined with two layers of fire rated gypsum wallboard on metal frame work and the outer shaft (unoccupied levels) is lined with two layers of gypsum wallboard.

There has been numerous water intrusion episodes reported occurring over the course of several years. The sources of water intrusion included roof leaks, water infiltration at pre-cast concrete panel joints due to deteriorated caulking, poor moisture and temperature control in the elevator shaft causing surface condensation, and deficiencies in the tower ventilation system allowing infiltration of unconditioned air. Numerous inspections were completed resulting in a general consensus to prevent moisture intrusion, rectify ventilation deficiencies, clean the visible 'surface' mold in the elevator shaft, and conduct mold remediation on the third, fourth, and ninth unoccupied levels of the tower.

To date, several FAA employees maintain that they have experienced allergic-like reactions and various illnesses thought to be related to the control tower environment.

EVALUATION METHODS

BIOAEROSOLS

A scope of work for this inspection was developed based on review of the various documents associated with the ATCT. This inspection included an inspection of the elevator shaft liner, the tower shaft (unoccupied levels), and the base building. Air sampling was conducted to evaluate bioaerosols, spores, airborne particulate, carbon dioxide, temperature, and relative humidity.

Bioaerosol sampling was performed using a single stage SAS Bioaerosol Sampler. The sampler draws air through a microsieve plate at a calibrated rate. This process accelerates airborne particles,

impacting them onto malt extract agar filled plates. The samples were incubated at 25°C and examined everyday for 7-10 days. Once on the agar plates, viable particles can grow into visible colonies. Their numbers give an indication of the airborne concentration of viable fungi and bacteria. During the incubation period subsequent colonies are isolated, identified to genus and counted to calculate airborne concentrations for each sample location.

SPORE SAMPLING

Microbial spore sampling was performed by drawing air through an Aerotrap spore sampler and aimed directly at a sticky and optically clear sampling media (microscope slide). An air-sampling rate of fifteen liters per minute was used. This process accelerates airborne particles, impacting them onto the gel strip inside the sampler. The slides were analyzed via microscopy and particles identified.

CARBON DIOXIDE

Carbon dioxide levels were measured using a KD Engineering Air Box Monitor. The instrument uses a non-dispersive infrared (NDIR) detector and was calibrated against a certified gas standard. Concentrations were spot checked at each sampling location.

CARBON MONOXIDE

Carbon monoxide levels were monitored using the KD Engineering Air Box Monitor. Concentrations were spot checked at each sampling location. The sampling was conducted simultaneously with carbon dioxide testing.

TEMPERATURE AND RELATIVE HUMIDITY

Temperature and relative humidity were monitored with the Air Box Monitor. Measurements were recorded for each sampling location. The sampling was conducted simultaneously with carbon dioxide testing.

AIRBORNE PARTICULATE

Particulate sampling was performed with a TSI Aerotrak (Model 8220) optical particle counter. This monitor uses laser technology to determine size of airborne particles. Particles are counted in six different size ranges.

RESULTS/DISCUSSION

INSPECTION

FAA has completed several of the recommended items contained in the Jacobs Engineering report entitled Moisture Assessment Report for the ATCT at Detroit Metropolitan Airport (August 2005). The tower pre-cast panel joints were stripped and new backer rod and sealant installed. The exterior of the tower and base building were sealed (paint-like product) in April/May 2006. Several ventilation system deficiencies were corrected to allow for sufficient air flow and conditioning of supply air to positively pressurize the tower thus preventing the infiltration of moisture and particulate laden air. Moisture sensors have been installed in the elevator shaft and at select locations of the tower shaft in an effort to monitor conditions in the shaft so that appropriate controls can be applied when needed (such as tempered air in winter months). The monitors were activated at the time of this inspection. Roof leaks in the cab have been sealed. Apparent mold growth (on drywall) noted on the third, fourth, and ninth levels were removed and drywall replaced.

Apparent mold growth on elevator shaft drywall was cleaned. An appropriate response plan has been implemented for leaks in general in the tower and base building.

A walk-through inspection was conducted in the tower and base building with concentration placed on the elevator shaft and the fourth and ninth unoccupied levels. The inspection of the elevator shaft was conducted from the roof of the elevator car. The car was stopped at every other level so that two levels of the shaft were inspected at each stop. There were no current signs of moisture intrusion or apparent mold growth in the elevator shaft. Several dried water stained/rust colored areas were noted and several discolored areas (surface mold removed) were noted also. A moldy or musty odor was not noted in the elevator shaft. The elevator pit sump was dry and the pit was relatively clean.

Drywall panels were physically removed from the fourth and ninth unoccupied levels corresponding to the discolored or cleaned areas within the elevator shaft. Drywall panels were removed from previously abated areas on both levels. The removal of the panels allowed for the inspection of the back side of the inner layer of the fire rated drywall of the elevator shaft liner without compromising the fire rating of the elevator liner. On the ninth level (928) two wall sections of the elevator shaft drywall were removed. Apparent mold growth was noted at both locations on the back surface of the outer layer of drywall, on the front surface of the inner layer of drywall, and on the back surface of the inner layer of fire rated drywall (inner layer of shaft liner). Apparent mold growth was identified on the backing of drywall located at the perimeter wall (at a column/cross member) also. This drywall was remediated previously. On the fourth level (428) drywall was removed from one wall of the elevator shaft wall. Minimal apparent mold growth was noted only on the back surface of the inner layer of fire rated drywall (inner layer of shaft liner) which corresponded specifically with an area of discoloration at the front corner (at floor level) of the elevator shaft liner.

The walk-through inspection included other levels of the tower and the first and second floor of the base building. There were no current signs of moisture intrusion with the exception of the roof leak in the second floor corridor adjacent to the janitor closet/roof access. The roof leak appeared to be at a roof drain. There were no signs of apparent mold growth. A moldy or musty odor was not noted in the base building. The existing built-up roof is composed primarily of fiberglass and asphalt products. The existing metal decking appeared intact at several inspection points.

BIOAEROSOLS

Bioaerosols are airborne particles that are living or that are released from living organisms. These living particles include fungi, bacteria, and plant pollens. Many of these particles have been implicated in human respiratory and skin allergies, hypersensitivity reactions and toxic effects.

Fungal spores and other viable particles may enter a space through the outside air intakes and due to their small size, are not effectively eliminated from the air stream by the air filtration system. Once they have settled out of the air stream, the spores may grow almost anywhere within a building where conditions permit. Optimal conditions include: a surface for growth, organic nutrients, darkness, and moisture. These conditions are often provided in the indoor environment. Areas in which microorganisms may proliferate or bioamplify include internal surfaces of air handling units and ducts, especially if insulated, ceiling tiles (wet or moist), carpet, and areas which remain dark, seldom cleaned, or congested with furniture and office materials.

Indoor environmental bacterial populations can be from humans as well as environmental sources. All humans shed skin flakes and bacteria. Commonly detected bacteria in indoor environments such as *Micrococcus* and *Staphylococcus* likely originate from human sources. Environmental bacteria such as *Bacillus* and *Pseudomonas* normally originate from soils, plants, or water.

Generally, there is insufficient evidence to show that bacteria are a cause of allergies. Exposure to significant concentrations of airborne bacteria could challenge an individual's immune system. However, bacterial byproducts (proteins and endotoxins) have been suggested as causative agents for occupant illnesses such as Monday morning fever. Monday morning fever is an allergic reaction to endotoxins produced by Gram negative bacteria such as *Pseudomonas* and *Flavobacterium*.

Fungi (molds and yeast) produce spores during their growth or reproductive cycle. The asexual and/or sexual spores are often considered allergens. It is not known what concentration of spores is required to evoke an allergic reaction. It is known, that individuals exposed intermittently to significantly elevated levels of allergens or moderate levels continuously for a time period (months or years) may become sensitized. An individual sensitized to an allergenic agent is said to have developed an allergy to that agent. Once sensitized, the individual experiences an allergic reaction at each time of exposure. The degree and extent of the reaction is dependent on the exposure concentration, the length of exposure and the individual. Therefore, a sensitized individual may react to relatively low and in some cases undetectable concentrations of allergens while a non-sensitized or less sensitized individual in the same indoor environment will not experience any symptoms.

Airborne fungi and bacteria naturally occur in most indoor environments. Currently, there are neither indoor air quality guidelines nor regulations for the determination of measured bioaerosol concentrations. However, excessive numbers or unusual types of microorganisms may cause health problems in sensitive individuals. Interpretation of such sample results depends on professional judgment as to whether types and amounts of organisms are comparable to normal background and the likelihood that the identified organisms will cause allergic reactions or infections. Since spores are only released into the air intermittently, any visible growth, water damage, or excessive dust may be considered an indication of potential bioaerosol problems, even where air sampling results are negative.

Bioaerosol samples were collected at five tower levels, two base building locations, and outdoors for comparison. The sampling was conducted at two time periods beginning at approximately 8:30 AM and 11:30 AM. The detected fungal concentrations for the first sampling period were insignificant. The indoor concentrations were less than the outdoors. However, the fungus, *Stachybotrys* was detected on the ninth and fourth unoccupied levels. Although this fungus is common in the environment it should not be present in the indoor environment. If detected, it is an indicator of chronic water intrusion and colonization of cellulose based building materials. The detection of *Stachybotrys* could have been due to the disturbance created during drywall panel removal to facilitate wall cavity inspections. *Stachybotrys* produces a sticky spore that does not readily become airborne unless physically disturbed. Exposure to *Stachybotrys* would not present any more of a health hazard than exposure to any other fungus in which an individual has become sensitized. Again, the degree and extent of the reaction is dependent on the exposure concentration.

the length of exposure, and the individual. The detected environmental bacteria concentrations were insignificant. The primary bacteria detected were human associated.

The detected fungal concentrations for the second sampling period were insignificant. Two colonies of *Stachybotrys* were detected on the fourth level. The detected environmental bacteria concentrations were insignificant. The primary bacteria detected were human associated. A full listing of sites sampled, species found, and concentration of each can be found in Appendix A.

SPORE SAMPLING

Spore samples were collected at five tower levels, two base building locations, and outdoors for comparison. The sampling was conducted at two time periods beginning at approximately 8:30 AM and 11:30 AM. Indoor spore concentrations were lower than the outdoor concentration. The sample locations and concentrations are summarized in the attached table 2.

CARBON DIOXIDE

Carbon dioxide is a colorless, odorless, non-combustible gas that is a natural by-product of human respiration, fermentation, and combustion. Carbon dioxide has many important functions in maintaining normal body activities and is a key factor in the control of respiration and cerebral circulation. Plants consume carbon dioxide. As a result of the production consumption process, an atmospheric carbon dioxide concentration of 300 parts per million is typical.

The carbon dioxide data was used to determine the effectiveness of the ventilation system in supplying outside air to the indoor environment. NIOSH recommends to prevent employee discomfort, average carbon dioxide concentrations should not exceed 1,000 ppm. The American Society of Heating, Refrigerating and Air Conditioning Engineers (ASHRAE) recommends that indoor carbon dioxide concentrations should not be in excess of 700 ppm over the outdoor concentration.

Average carbon dioxide concentrations were within the ASHRAE recommendation. The average carbon dioxide concentration for each sampling location was as follows:

| Location | CO2 Average |
|--|-------------|
| Tower cab | 455 |
| Tower break room | 595 |
| Tower union office | 657 |
| Level 928 | 671 |
| Level 428 | 817 |
| TRACON | 690 |
| Base - 1 st floor office (near 109) | 515 |
| Outdoors | 375 |

ASHRAE recommends that office workers be supplied with 20 cubic feet per minute of outside air per occupant, in order to maintain acceptable carbon dioxide levels. This is based on an occupancy rate of seven occupants per 1,000 square feet (143 sq. ft./occupant) of floor space. The supplied cubic footage per minute of outside air per occupant may be determined with detected carbon dioxide levels with the use of the following ASHRAE derived equation:

$$\text{cfm/person} = \frac{10,500}{\text{CO}_2 \text{ (indoor)} - \text{CO}_2 \text{ (outdoor)}}$$

Carbon dioxide levels below 900 ppm, based on a 375 ppm outdoor concentration would indicate sufficient outside air was introduced at or above 20 cfm/person.

CARBON MONOXIDE

Carbon monoxide (CO) is one of the most prevalent of all indoor air pollutants, introduced into a building from combustion sources. Indoor sources for air contamination can be produced from tobacco smoke, improperly vented combustion sources, or from leaking heat exchangers.

OSHA has established a PEL of 50 parts of CO per million parts of air for an 8-hour industrial exposure. At this level of exposure, it is felt that most people will not experience any adverse health effects. The ambient air quality standard for CO, set by the U.S. Environmental Protection Agency (EPA), is 9 ppm and is considered more appropriate for application to office environments.

The average carbon monoxide concentrations at each sampling location (identical to carbon dioxide locations) were consistently less than 5.0 ppm.

TEMPERATURE AND RELATIVE HUMIDITY

The primary functions of a building's ventilation system are to control temperature and humidity and to provide clean outdoor air for the dilution of odors and air contaminants. ASHRAE Standard 55-1992: *Thermal Environmental Conditions for Human Occupancy* is utilized for guidance on air temperatures, relative humidity, air movement and other thermal comfort parameters. Many complaints of poor air quality are actually caused or exacerbated by temperature and/or humidity values outside of the normal comfort ranges of 73-79°F and 40-60% humidity for summer or 68-74.5°F and 30-50% humidity for winter. The temperatures and relative humidity are summarized in the following table.

| Location | Average Temperature (°F) | Average Relative Humidity (%) |
|--|--------------------------|-------------------------------|
| Tower cab | 72.1 | 28 |
| Tower break room | 73.1 | 29 |
| Tower union office | 75.2 | 30 |
| Level 928 | 74.3 | 29 |
| Level 428 | 70.7 | 35 |
| TRACON | 75.9 | 29 |
| Base - 1 st floor office (near 109) | 74.9 | 25 |
| Outdoors | 72.1 | 25 |

The average temperatures were within or insignificantly below the ASHRAE recommended range for summer (73-79°F). The average relative humidity was within or insignificantly below the ASHRAE recommended range of 40-60% for summer.

AIRBORNE PARTICULATE

Airborne particulate sampling was conducted at each sampling location (same as bioaerosols). This sampling was conducted as a screening to indicate the possibility that airborne mold spores were present in the indoor environment in lieu of other sampling techniques. Generally, the physical size of mold spores is in the range of 3 to 10 microns.

The particle counter counts particles in six size ranges. The detected particle counts, in each size range, are summarized in the attached table. The particle count for each size range and at each location was not significant when compared to the outdoors. During the AM sampling period there was an increase at the fourth and ninth levels; however, it occurred in all six ranges and was believed to be related to the resultant dust generated by removal of drywall panels and by individuals walking in the room. The same scenario appeared to have affected the PM sampling results.

VENTILATION

Dilution ventilation is used to control indoor air contaminants such as carbon dioxide, water vapor, particulate matter, biological aerosols and volatile organic compounds.

The ventilation of the tower (occupied levels) is provided by one unit located in a mechanical room on the junction level. Outside air is provided to the unit. The general condition of the unit was good. The filters (charcoal and pleated) were properly installed. Reportedly the pleated filters are changed quarterly and the charcoal filters changed approximately every six months. FAA has an O&M plan in place for unit maintenance and cleaning. The base building ventilation is provided by a roof mounted unit. Outside air is provided to the unit. Reportedly the pleated filters are changed quarterly. O&M procedures are completed at regularly scheduled intervals.

CONCLUSIONS/RECOMMENDATIONS

The inspection of wall cavities on the fourth and ninth floors revealed that apparent mold growth is present in the ATCT. The location of the apparent mold growth observed and the previously abated contaminated drywall was likely caused by water intrusion. Based on the Jacobs Engineering inspection report water/moisture was able to enter the tower shaft at joints in the pre-cast concrete panels where deteriorated caulking and backer rod was unable to prevent moisture intrusion. The likely scenario is that water pooled on a given level's concrete floor and through wicking action was taken into the drywall thus allowing mold colonization. Furthermore, it is likely that the introduction of moisture laden air into the tower environment caused condensation to occur and further add moisture to the drywall. The surface mold previously observed and subsequently removed from the elevator shaft liner could have been due to condensation and/or poor moisture/temperature control of the elevator shaft environment.

Several corrective actions have been completed in the ATCT. Mold contaminated drywall was removed from several unoccupied levels of the tower. The exterior surface of the ATCT and base building were sealed with a moisture resistant sealant. Deteriorated caulking and backer rod was removed from pre-cast joints and replaced. Heaters have been installed and ventilation system modifications have been completed in an effort to control and or prevent condensation in the ATCT and moisture and temperature sensors were installed to monitor conditions in the elevator shaft and unoccupied tower levels. Also, cab roof leaks were sealed.

Based on the corrective actions completed thus far, the bioaerosol sampling results obtained during this survey, and the location of apparent mold growth it is suspected that FAA employees are not exposed to significant bioaerosol concentrations. Apparent mold growth was not noted on outward surfaces of drywall in the elevator shaft or on unoccupied level walls. The identified apparent mold growth was located between layers of intact drywall and in unoccupied areas. The unoccupied

areas are not serviced by existing ventilation systems currently servicing occupied levels of the tower and totally independent from the base building ventilation systems. The only connection would be the air moved through the piston action of the elevator car in the elevator shaft which contains relief vents allowing air to be discharged at the top and bottom of the shaft.

Based on the sampling results and observations the following recommendations are offered.

- Perform comprehensive inspection of the elevator shaft drywall liner to identify mold contamination.
- Completely remove (plus one foot beyond visible contamination) any porous material, such as drywall, which is visibly contaminated with mold or stained. Do not attempt to clean porous materials. Clean remaining non porous substrates, and replace building materials as necessary. A water/detergent solution with a stiff bristle brush is sufficient followed by rinsing with water/detergent solution. Chemical biocides are not recommended. The remediation must be conducted in a similar manner as asbestos abatement and as previously performed on the third, fourth, and ninth unoccupied levels of the ATCT. Containments should be constructed with restricted access. A negative pressure/air filtration system must be installed and the system should be exhausted to the tower staircase. The removal and cleaning process should not be conducted until negative pressure has been established in each containment. Also, the placement of contact paper (one side sticky) over apparent mold growth prior to physical removal of drywall will minimize the amount of airborne spores and fungal particulate. The collection of spore trap samples can be used for containment clearance purposes; however, there is no substitute for a thorough visual inspection at the completion of the abatement process. The abatement process should be conducted overnight when minimal FAA employees are present.
- Proceed with the base building roof replacement. The roof must be replaced as it is the major source of water intrusion remaining. A rubber membrane roof with heat sealed seams has been specified. Evaluate material safety data sheets for all materials to be used for the roof replacement and ensure adequate control measures are in place and implemented to prevent infiltration of airborne volatile organic compounds likely to be generated from the roof replacement process. Consideration should be given to conducting the roof replacement during night hours.
- Remove drywall from unoccupied levels of the ATCT other than drywall necessary to maintain the required fire rating of the elevator shaft. If it is necessary to install drywall on unoccupied levels of the ATCT; replace drywall currently in contact with concrete floors with drywall installed with at least a one half inch gap or provide a strip of silicone caulking at the concrete/drywall junction to prevent condensation and/or moisture intrusion from wicking into the drywall.
- Alternatively, evaluate the fire rating for cement or backer board or mold resistant drywall now commercially available to be used as a substitute material for the removed drywall. Install a two foot high strip (from the floor) of a substitute material for walls located on unoccupied tower levels.

- Remove and discard the existing carpet in the former union office located in the tower.
- Monitor temperature and moisture levels in the elevator shaft and unoccupied levels and implement corrective actions as necessary to prevent condensation on surface materials.
- Continue to inspect the ATCT on a regular basis and remove and replace water damaged building materials as necessary.

Table I
 Bioaerosol Sampling Results
 Detroit ATCT
 May 19-20, 2008

| Location | Fungal/Bacterial ID | Colony Counts | Concentration (cfu/m ³) |
|--|--------------------------------------|---------------|-------------------------------------|
| Tower Cab (AM) | No Growth | <1 | |
| | Total Fungi | <1 | <7 |
| | Coag-negative Staphylococcus species | 2 | 14 |
| | Micrococcus species | 2 | 14 |
| | Total Bacteria | 4 | 28 |
| Tower Break room (AM) | No Growth | <1 | |
| | Total Fungi | <1 | <7 |
| | Coag-negative Staphylococcus species | 2 | 14 |
| | Micrococcus species | 3 | 21 |
| | Total Bacteria | 5 | 35 |
| Union Office (tower) | Non-sporulating colony | 1 | 7 |
| | Total Fungi | 1 | 7 |
| | Micrococcus species | 10 | 70 |
| | Total Bacteria | 10 | 70 |
| Level 928 | Penicillium species | 5 | 35 |
| | Stachybotrys species | 7 | 49 |
| | Ulocladium species | 3 | 21 |
| | Total Fungi | 15 | 105 |
| | Bacillus species | 6 | 42 |
| | Coag-negative Staphylococcus species | 6 | 42 |
| | Micrococcus species | 12 | 85 |
| | Total Bacteria | 24 | 169 |
| Level 428 | Cladosporium species | 2 | 14 |
| | Penicillium species | 2 | 14 |
| | Stachybotrys species | 1 | 7 |
| | Ulocladium species | 1 | 7 |
| | Total Fungi | 6 | 42 |
| | Coag-negative Staphylococcus species | 7 | 49 |
| | Micrococcus species | 7 | 49 |
| | Total Bacteria | 14 | 98 |
| TRACON | Rhizopus species | 1 | 7 |
| | Total Fungi | 1 | 7 |
| | Coag-negative Staphylococcus species | 3 | 21 |
| | Micrococcus species | 4 | 28 |
| | Total Bacteria | 7 | 49 |
| Base Building 1 st Floor office | Aspergillus versicolor | 1 | 7 |
| | Cladosporium species | 1 | 7 |
| | Total Fungi | 2 | 14 |
| | Coag-negative Staphylococcus species | 2 | 14 |
| | Micrococcus species | 7 | 49 |
| Total Bacteria | 9 | 63 | |

Table 1 (continued)
 Bioaerosol Sampling Results
 Detroit ATCT
 May 19-20, 2008

| Location | Fungal/Bacterial ID | Colony Counts | Concentration (cfu/m ³) |
|----------------------|--------------------------------------|---------------|-------------------------------------|
| Outdoors (roof) | Alternaria species | 2 | 14 |
| | Aspergillus fumigatus | 2 | 14 |
| | Cladosporium species | 12 | 85 |
| | Non-sporulating colonies | 4 | 28 |
| | Total Fungi | 20 | 141 |
| | Bacillus species | 6 | 42 |
| | Coag-negative Staphylococcus species | 3 | 21 |
| | Total Bacteria | 9 | 63 |
| Tower Cab (PM) | No Growth | <1 | |
| | Total Fungi | <1 | <7 |
| | Coag-negative Staphylococcus species | 1 | 7 |
| | Total Bacteria | 1 | 7 |
| Tower Breakroom (PM) | Coelomycete species | 1 | 7 |
| | Rhodotorula species | 1 | 7 |
| | Total Fungi | 2 | 14 |
| | Coag-negative Staphylococcus species | 5 | 35 |
| | Micrococcus species | 3 | 21 |
| | Total Bacteria | 8 | 56 |
| Union Office (tower) | Cladosporium species | 2 | 14 |
| | Total Fungi | 2 | 14 |
| | Coag-negative Staphylococcus species | 13 | 92 |
| | Micrococcus species | 5 | 35 |
| | Total Bacteria | 18 | 127 |
| Level 928 | Non-sporulating colony | 1 | 7 |
| | Stachybotrys species | 2 | 14 |
| | Ulocladium species | 2 | 14 |
| | Total Fungi | 5 | 35 |
| | Coag-negative Staphylococcus species | 6 | 42 |
| | Micrococcus species | 8 | 56 |
| | Total Bacteria | 14 | 98 |
| Level 428 | Cladosporium species | 2 | 14 |
| | Penicillium species | 1 | 7 |
| | Ulocladium species | 1 | 7 |
| | Total Fungi | 4 | 28 |
| | Coag-negative Staphylococcus species | 7 | 49 |
| | Micrococcus species | 10 | 70 |
| | Total Bacteria | 17 | 119 |
| TRACON | Ulocladium species | 1 | 7 |
| | Total Fungi | 1 | 7 |
| | Coag-negative Staphylococcus species | 5 | 35 |
| | Micrococcus species | 1 | 7 |
| | Total Bacteria | 6 | 42 |

Table 1 (continued).
 Bioaerosol Sampling Results
 Detroit ATCT
 May 19-20, 2008

| Location | Fungal/Bacterial ID | Colony Counts | Concentration (cfu/m ³) |
|---|--------------------------------------|---------------|-------------------------------------|
| Base Building 1 st Floor office | Yeast | 1 | 7 |
| | Total Fungi | 1 | 7 |
| | Coag-negative Staphylococcus species | 3 | 21 |
| | Micrococcus species | 2 | 14 |
| | Total Bacteria | 5 | 35 |
| Outdoors | Alternaria species | 2 | 14 |
| | Cladosporium species | 12 | 85 |
| | Non-sporulating colonies | 2 | 14 |
| | Penicillium species | 1 | 7 |
| | Yeast | 1 | 7 |
| | Total Fungi | 18 | 127 |
| | Coag-negative Staphylococcus species | 219 | 1,542 |
| | Total Bacteria | 219 | 1,542 |

Table 2
Spore Sampling Results
Detroit ATCT
May 19-20, 2008

| Location | Presumptive Fungal ID | Counts of Fungal Structures | Fungal Structures/m ³ |
|--|-------------------------------|-----------------------------|----------------------------------|
| Tower Cab (AM) | None | <1 | Total: <13 |
| Tower Breakroom (AM) | None | <1 | Total: <13 |
| Union Office (tower) | Cladosporium | 2 | Total: 27 |
| Level 928 | Alternaria | 1 | |
| | Penicillium/Aspergillus group | 6 | |
| | Stachybotrys | 1 | |
| | Unknown | 1 | Total: 119 |
| Level 428 | Alternaria | 1 | |
| | Cladosporium | 2 | Total: 40 |
| TRACON | Smuts,Periconia,Myxomycetes | 2 | Total: 27 |
| Base Building 1 st Office Floor | None | <1 | Total: <13 |
| Outdoors (base roof) | Ascospores | 5 | |
| | Basidiospores | 36 | |
| | Cladosporium | 7 | |
| | Epicoccum | 1 | |
| | Hyphal Elements | 4 | |
| | Penicillium/Aspergillus group | 2 | |
| | Smuts,Periconia,Myxomycetes | 3 | Total: 773 |
| Tower Cab (PM) | Algae | 1 | |
| | Basidiospores | 1 | |
| | Smuts,Periconia,Myxomycetes | 2 | Total: 53 |
| Tower Breakroom (PM) | Penicillium/Aspergillus group | 1 | Total: 13 |
| Union Office (tower) | Basidiospores | 1 | |
| | Cladosporium | 2 | |
| | Hyphal Elements | 1 | |
| | Smuts,Periconia,Myxomycetes | 1 | Total: 66 |
| Level 928 | Alternaria | 1 | |
| | Cladosporium | 1 | |
| | Hyphal Elements | 1 | |
| | Penicillium/Aspergillus group | 1 | |
| | Stachybotrys | 1 | Total: 65 |
| Level 428 | None | 0 | Total: <13 |
| TRACON | Basidiospores | 1 | Total: 13 |
| Base Building 1 st Floor Office | Penicillium/Aspergillus group | 2 | |
| | Smuts,Periconia,Myxomycetes | 1 | Total: 40 |
| Outdoors | Ascospores | 7 | |
| | Basidiospores | 43 | |
| | Cladosporium | 5 | |
| | Colorless | 1 | |
| | Smuts,Periconia,Myxomycetes | 4 | Total: 799 |

Table 3
 Particle Count
 Detroit ATCT
 May 19-20, 2008

| Location (AM) | Particle Size (micron) | | | | | |
|------------------|------------------------|-------|------|------|------|-----|
| | 0.3-0.5 | 0.5-1 | 1-3 | 3-5 | 5-10 | >10 |
| Tower Cab | 3521 | 272 | 98 | 56 | 35 | 27 |
| Tower Breakroom | 5978 | 356 | 115 | 40 | 19 | 22 |
| Union Office | 9388 | 736 | 515 | 284 | 206 | 113 |
| Level 928 | 12732 | 1714 | 1331 | 819 | 584 | 206 |
| Level 428 | 22146 | 3825 | 2964 | 1769 | 1198 | 301 |
| TRACON 212 | 5394 | 212 | 70 | 30 | 22 | 29 |
| 109 | 6558 | 324 | 163 | 111 | 90 | 29 |
| Outside | 52939 | 2501 | 385 | 103 | 66 | 19 |

| Location (PM) | Particle Size (micron) | | | | | |
|------------------|------------------------|--------|--------|--------|-------|-------|
| | .3-.5 | .5-1 | 1-3 | 3-5 | 5-10 | >10 |
| Tower Cab | 9555 | 1073 | 167 | 48 | 42 | 10 |
| Tower Breakroom | 7172 | 752 | 277 | 105 | 70 | 26 |
| Union Office | 9985 | 780 | 426 | 252 | 185 | 97 |
| Level 928 | 10707 | 640 | 243 | 128 | 112 | 44 |
| Level 428 | 362088 | 182537 | 174390 | 103522 | 85340 | 35466 |
| TRACON 212 | 1556757 | 92056 | 37464 | 16769 | 12131 | 3211 |
| 109 | 6054 | 406 | 200 | 113 | 92 | 32 |
| Outside | 73072 | 4256 | 286 | 105 | 91 | 10 |

19

SAFE TECHNOLOGY, INC.



June 7, 2007

Mr. Wayne Vogelsburg
Safety Assurance Group AJO-2C1
2601 Meacham Blvd
Fort Worth, TX 76137

Re: DTW ATCT WME Report Review
Project #2006-0269

Dear Wayne,

Per your request I have reviewed the documents described as Investigation Data and Associated Correspondence, Project Number IA06-7235, prepared by Wonder Makers Environmental (WME) for NATCA, their client. The report described the findings and recommendations resulting from their December 18, 2006, December 19, 2006, January 22, 2007 and January 23, 2007 visits at the Detroit Metro (DTW) ATCT.

Background

On the dates described above, WME visited the DTW ATCT, and associated base building, and gathered a variety of samples, including cultured (viable) and non-cultured (non-viable) air samples, surface swabs and particulates vacuumed from surfaces. Additionally, room temperature and relative humidity were measured. Photographs were included in the report. I was not present during the WME visit.

Discussion

Conclusions and recommendations provided by WME are largely dependent on the outcome of their sampling efforts. Unfortunately, deficiencies in the methods utilized by WME preclude drawing meaningful conclusions from much of the data. The sampling that was conducted seemed to be directed at finding mold rather than evaluating conditions in a carefully planned and objective manner.

Air Samples

Air sampling is not usually necessary to determine the presence and severity of mold growth within a building. When mold growth occurs as a result of floods, or chronic wetting of finishes, it is usually visible to the unaided eye. On occasions, such as when microbial growth is suspected, but may be concealed and cannot be seen, air sampling may be a useful tool. In those cases, considerable care must be exercised when designing a sampling strategy that will permit meaningful conclusions to be made. Indoor areas of concern are usually compared to the outdoors, or to other areas of the building thought to be in acceptable condition.

Airborne concentrations of microbial agents are known to be extremely variable, temporally and spatially, therefore the number of air samples to be gathered at each location of interest must be adequate to define the distribution as well as the mean.

Comparisons of areas of interest typically involve two components; comparison of means of total spore counts, and comparison of taxa, preferably at the species level^{1,2}. Buildings in good condition will usually have indoor concentrations of mold spores that are less than outdoor concentrations. Weather and season can influence the results and must be considered. Buildings in good condition will also have a similar distribution of taxa at the locations of interest. Similarity is determined through the Spearman rank order correlation test using mean taxa values from each location.

Unfortunately, an air-sampling plan defining the areas of concern, reference locations, and the number of samples needed at each location to make meaningful and reliable comparisons was not described or implemented by WME.

Relatively few cultured air samples were collected from the site. Air sampling conducted by WME was inadequate to compare areas of interest with reference locations. No conclusions could be drawn from this data.

Most of the air samples were collected on Air-O-Cell cassettes that permitted identification of some spores to the genus level only, based on morphology of the structures. This limiting factor somewhat reduced the ability to compare areas of interest. In any event, WME did not evaluate this data in any systematic or recognized manner.

As reported by WME, a large percentage of their Air-O-Cell samples were too obscured by particulates to permit normal analysis. WME concluded this was evidence of 'ventilation and filtration problems' in the building, when it was actually the predictable outcome of poor technique. The samples were rendered useless simply because the sample air volume was excessive. The 'alternative' analytical technique employed by WME for these samples was never described, but appeared to be the same method used to evaluate their microvac samples (see discussion below). The outcome of this alternative analysis demonstrated that, in all cases, mold spores made up less than one percent of the particulates 'quantified'. Interestingly, this 'less than one percent' fraction was excluded from category totals, which were classified as the 'estimated percent of sample'. Even so, WME reported genera of spores present within this excluded fraction down to the single percentile level. It is not at all clear how this was accomplished.

WME noted that analysis of Air-O-Cell samples was conducted in house via their own protocol. The data sheets revealed that the reported 'target fungal spores types' were not actually encountered during the normal counting procedures. They were reported only as part of the 'qualified analysis' which appeared in some of the 'notes' sections. This suggested that these spore types occurred very rarely, or they would have also appeared in a field that was counted. They clearly were not quantified.

When forming their conclusions, WME seemed to rely heavily on information that was only anecdotal at best. See also comments related to 'target fungal spore types' below.

Air-O-Cell Data Analysis

While most WME air sampling data was inadequate to be used for forming conclusions, the large number of Air-O-Cell samples collected over several days presented an opportunity for analysis, though with limitations. Samples that were not overloaded were separated into three groups; outdoors, indoor tower and indoor base building. The mean total spore counts were compared, as were the rank order of observed genera. Results are provided in Attachment 1.

Analysis revealed that mean outdoor concentrations of total mold spores were higher than mean concentrations in both the tower and base buildings. When the means of the base building and tower building were compared, there was no meaningful difference.

When the Spearman rank order correlation test was used to compare mean genera data, a difference in biodiversity was not detected. In other words, the genera observed in both indoor and outdoor samples appeared to originate from the same source.

The data strongly suggested that a source of microbial growth did not exist within the buildings. It is not clear why WME did not perform a similar evaluation of their data.

Aspergillus/Penicillium Limitations

As noted by WME, aspergillus and penicillium spores are essentially indistinguishable under the light microscope, and are therefore usually reported collectively as aspergillus/penicillium. This is simply a limitation of the light microscopy technique that must be considered when interpreting data. There are approximately 200 different species of penicillium and the same for aspergillus. This means up to 400 different species might actually be lumped into the aspergillus/penicillium finding. Because the light microscope cannot distinguish the species, or even the genus, of these spores, care must be exercised when drawing conclusions from this type of data, and the limitations must be acknowledged. This was a limiting factor within the evaluation I performed above.

Penicillium and aspergillus species are ubiquitous in the environment. Penicillium is commonly found in ordinary house dust, even in environments not subjected to water damage. Some species of aspergillus are xerophilic, and do not require free water for growth.

Swab Samples

Like all techniques, swab sampling has limitations that must be understood. The usefulness of the WME results was extremely limited, and even potentially misleading. Since WME did

not estimate the area of the surface the sample was to represent the data had limited value, other than to conclude that some mold (or bacteria) was, or was not, found.

Since mold spores are extremely small, a very large number might be found on a spot no larger than the period at the end of this sentence. A one-millimeter spot on the wall will easily accommodate more than 160,000 mold spores that are about 2.5 microns in diameter. The highest concentration of spores found by WME was 23 spores per square centimeter, an area that is 100 times larger than my one-millimeter example. In absence of an estimation of the area represented by the swab sample, not much can be concluded other than perhaps some small fraction of a tiny dot of mold was encountered. Certainly, this form of data did not permit the sweeping conclusion that the building had been adversely impacted by mold.

My impression of the WME data is that remarkably little mold was found through swab sampling. This was surprising considering how ubiquitous mold is in the environment.

Microvac Samples

Microvac samples were gathered by vacuuming a surface with an Air-O-Cell cassette attached to an air pump. The device is the same one used for the collection of non-cultured (non-viable) air samples. It shares all of the limitations of that technique, with the additional complications created by using an inertial impactor designed for air sampling for vacuuming particles from surfaces.

WME described findings as relative percentages of various categories. 10 of 15 samples indicated that fungal spores made up less than one percent of the material reported. The remainders ranged from one to five percent. The contents of sample 7235-E12 added up to 102% without explanation.

WME utilized a unique interpretation scheme for these results. They interpreted fungal spores at one percent or less (absent 'target fungal types') as 'normal fungal ecology'. Fungal spores at more than one percent, but less than three percent represented an 'environment contaminated with settled spores that were dispersed directly or indirectly'. Fungal spores at greater than three percent were 'an indication of an indoor environment contaminated with the presence of actual mold growth and associated spores'. These criteria were, apparently, based solely on WME's own experience, and did not reference any published work. In absence of further explanation the criteria appeared to be completely arbitrary and without basis. Further, the analytical method was not described, and appeared to be another in-house method. No evidence of method validation was offered. Given the difficulty of accurately quantifying low concentrations of particulates via light microscopy, I do not believe the method can reliably distinguish such small differences in spore concentrations.

As in the case of swab samples, there was no estimation of the surface area the sample was intended to represent.

Bacteria

Air sampling for bacteria is of limited value in most environments because of uncertainties in interpretation. Most bacteria found in buildings are those shed by the human occupants. Comparison of indoor and outdoor environments therefore becomes problematic. Air sampling conducted by WME was inadequate to compare areas of interest with reference locations. No conclusions could be drawn from this data.

Target Organisms

The terms 'target fungal type', or 'target organism' are not standard nomenclature and are not recognized or defined in any of the published references commonly relied upon by professional investigators. WME seemed to use the term to convey special status upon a small number of genera, without any basis for doing so.

The infrequent occurrence of stachybotrys and other genera from WME's 'target' list within the building was far from conclusive evidence of present or even past moisture related problems. As illustration, a recent study demonstrated that stachybotrys was found in a significant portion of buildings, both commercial and residential, that were categorized as 'clean', meaning they had no history or indications of moisture related problems or microbial growth³.

Temperature and Relative Humidity

WME reported generally acceptable room temperature and relative humidity measurements at test locations.

Other Observations

Non-cultured air and microvac samples were analyzed by WME staff according to their own protocols. WME does not appear on the list of AIHA accredited laboratories participating in the Environmental Microbiology Laboratory Accreditation Program (EMLAP). AIHA accredited laboratories have successfully demonstrated personnel qualifications and quality assurance procedures, established standard operating procedures, maintain proper records, have adequate facilities and equipment, and additionally participate in the AIHA Environmental Microbiology Proficiency Analytical Testing (EMPAT) Program. Aerotech P&K, utilized by WME only for analysis of cultured samples, is EMLAP accredited.

Conclusions

The data provided in the WME report did not support a finding that the DTW air traffic control tower and base building was 'contaminated' with microbial growth. Airborne concentrations of mold spores within the building were less than the outdoors. The biodiversity of genera observed indoors and out was similar. The usable data strongly suggested the absence of a source of microbial amplification within the building.

DTW ATCT WME Report Review
Project #2006-0269
Page 6 of 11

In absence of evidence to suggest the presence of a significant concealed source of microbial growth within the building, there is no obvious benefit to invasive sampling.

Please contact me if you have an questions or require clarification.

Best Regards,

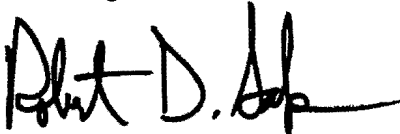

Robert D. Safe, CIH, LIH, QEP

References

1. Bioaerosols: Assessment and Control, ACGIH 1999.
2. Field Guide for the Determination of Biological Contaminants in Environmental Samples, Second Edition. AIHA 2005.
3. A Regional Comparison of Mold Spore Concentrations Outdoors and Inside "Clean" and "Mold Contaminated" Southern California Buildings. Daniel M. Baxter et al. , Journal of Occupational and Environmental Hygiene, 2: 8-18.

Attachment 1



Test | Comparative descriptives
 Variables | LN: OA, Tower, Base
 Performed by | R

Date | 6 June 2007

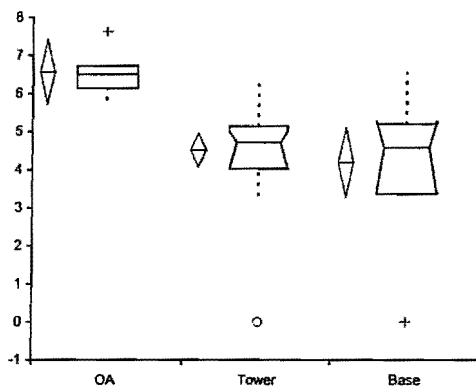

| LN | n | Mean | SD | SE | 95% CI of Mean | Median | IQR | 95% CI of Median |
|-------|----|-------|--------|--------|----------------|--------|-------|------------------|
| OA | 5 | 6.567 | 0.6805 | 0.3043 | 5.722 to 7.412 | 6.500 | 0.580 | - lo - |
| Tower | 32 | 4.515 | 1.2073 | 0.2134 | 4.080 to 4.951 | 4.718 | 1.118 | 4.025 to 6.011 |
| Base | 18 | 4.200 | 1.8269 | 0.4306 | 3.292 to 5.109 | 4.583 | 1.839 | 3.367 to 5.278 |

| | n | GMean |
|-------|----|---------|
| OA | 5 | 710.902 |
| Tower | 32 | 91.421 |
| Base | 18 | 66.720 |

Air-O-Cell data that was not overloaded was separated into outdoor, tower and base building categories based on the WME report. Because the data was lognormally distributed, it was first normalized by calculating the natural log (LN) for each value before the comparative statistical analysis, above, was performed. The resulting geometric mean values are also shown in the lower section of the table.

The results of parametric and non-parametric analysis are graphically displayed for ease of comparison. The centerlines of the diamond shape plots, and the box blots, indicate the mean values. The 95% confidence limit around the mean values are indicated by the plot boundaries. The outdoor mean value is clearly different from both indoor mean values. The indoor mean values cannot be distinguished, as the mean confidence intervals overlap.

The Spearman rank order correlation test, as described in reference 1, was performed. The resulting data is presented in tabular and graphical form. For $n=17$ the single tailed critical value, at $P=0.05$, was 0.4118. The calculated r_s statistic was compared against the critical value to accept, or reject, the null hypothesis that the populations were independent (not related), or the alternative hypothesis that the populations were not independent (they were related) The data demonstrated that the biodiversity of the populations were related. In plain English, the mold genera present in the indoor samples could not be reliably distinguished from the outdoor samples. Likewise, the samples from the tower and base buildings could not be distinguished. If there were a significant source of mold growing inside the buildings, we would expect the genera to be different from the outdoors.

analysed with: Analyse-it + General 1.73

| | | |
|-------------------------------|---------------------------|-------------------------|
| Test | Spearman rank correlation | |
| Alternative hypothesis | Spearman: OA \neq Tower | |
| Performed by | R | Date 6 June 2007 |

| | |
|---------------------|--|
| n | 17 |
| rs statistic | 0.54 |
| 95% CI | 0.09 to 0.81 |
| 2-tailed p | 0.0241 (1 approximation, corrected for ties) |

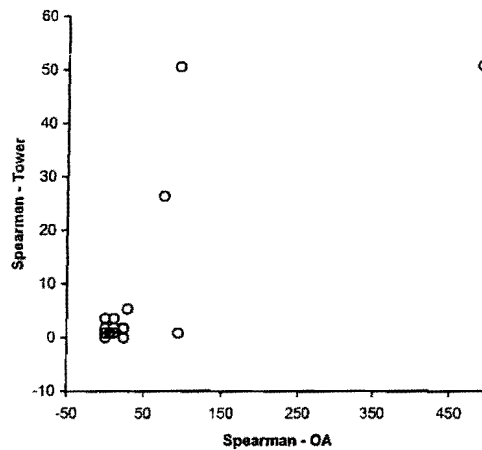

analysed with: Analyse-It + General 1.73

| | |
|-------------------------------|----------------------------------|
| Test | Spearman rank correlation |
| Alternative hypothesis | Spearman: OA \neq Base |
| Performed by | R |
| Date | 6 June 2007 |

n | 17

rs statistic | 0.54
95% CI | 0.08 to 0.81

2-tailed p | 0.0251 (t approximation, corrected for ties)

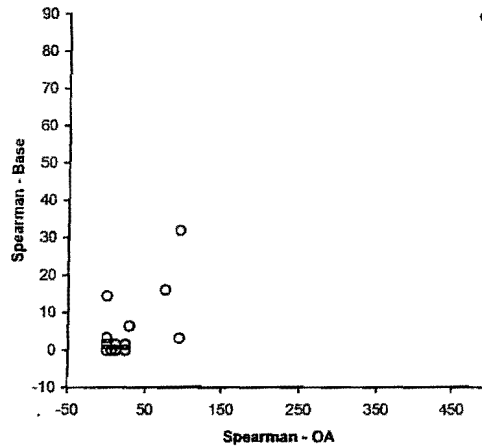

analysed with: Analyse-It + General 1.73

| | |
|------------------------|-----------------------------|
| Test | Spearman rank correlation |
| Alternative hypothesis | Spearman: Tower \neq Base |
| Performed by | R |
| Date | 6 June 2007 |

n | 17

rs statistic | 0.65
95% CI | 0.24 to 0.86

2-tailed p | 0.0049 (t approximation, corrected for ties)

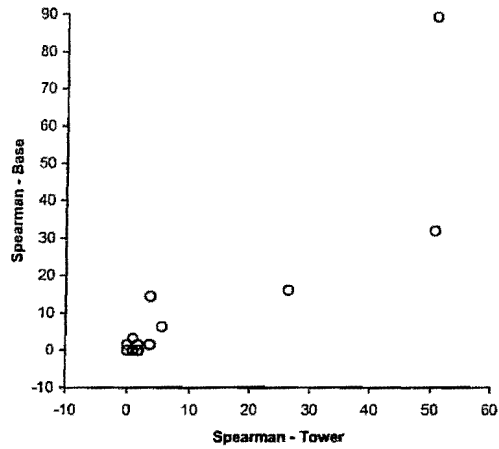

20

June 13, 2007

Mr. James Burton
Lockheed Martin Services, Inc.
400 Virginia Avenue, SW, Suite 500
Washington, D.C. 20024

Ref: Purchase Order 7100026924 – Mold Inspection, Detroit Air Traffic Control Tower

Dear Mr. Burton:

Under the above referenced Purchase Order, Applied Environmental, Inc. conducted a mold inspection within the Detroit Metropolitan Wayne County Airport (DTW) Air Traffic Control Tower (ATCT) located in Detroit, Michigan. The undersigned conducted the inspection. I am a Board Certified Industrial Hygienist (CIH) and a Board Certified Safety Professional (CSP) with over 25 years of applicable industrial hygiene experience, including performing mold and Indoor Air Quality (IAQ) assessments.

Background and Scope

A visual inspection for the presence of mold was performed within the entire ATCT and associated base building. Moisture testing and air and/or surface sampling for viable mold or non-viable (spore) sampling was beyond the scope of this assignment and were therefore not attempted. I was escorted throughout the facility by Mr. Steve McClinchey, DTWB SSC Manager, and Ms. Patricia Bynum, Support Manager, Plans and Programs. Mr. Vince Sugent also accompanied me in his capacity as union representative for the National Air Traffic Controllers Association (NATCA). The assistance of all three of these individuals was very much appreciated. As part of the visual inspection, photography was performed, as needed, to document the relevant conditions at the facility.

The facility is a 12 story tower connected to a 2 story base building with a basement. The basement houses offices, locker rooms, a lunch room, and the Terminal Radar Approach Control (TRACON) facility. A central elevator shaft extends from the basement to the 12th floor of the ATCT. Floors 3 to 10 are unoccupied spaces and are not conditioned.

It is my understanding that past water incursion events were documented in the structure and mold contamination was observed in areas of the tower on the 9th, 4th, and 3rd levels and within the elevator shaft itself. Contract work was completed which consisted of sealing and caulking the exterior of the tower to eliminate water incursion. Mold remediation, prompted by past visual inspections, consisted of removing sections of drywall from the 9th, 4th, and 3rd levels. Elevator shaft surfaces were cleaned using a High Efficiency Particulate Air (HEPA) vacuum and wiped with a detergent solution. A review of sampling data, remediation reports, and other documents was beyond the scope of this inspection.

Findings

In general, no visible mold growth or active sources of water incursion were observed and no unusual odors were noted in any spaces. Several ceiling tiles that had small areas of staining were observed in interior spaces of the ATCT and base building. In all cases, inspection above the ceiling grid revealed that the source of the staining was plumbing valves and joints that were not completely insulated, giving rise to condensation. On several levels of the tower, fireproofing on the ceiling (at an approximate 20-foot height) appeared to be stained. A visual inspection of the elevator shaft (conducted from the top of the elevator cab during the overnight shift) did not reveal evidence of active water incursion nor visible mold growth. Specific observations are provided in the table below and a photographic log is provided as Attachment A.

**Specific Observations During Site Inspection
 Detroit Air Traffic Control Tower**

| Location/Floor | Observations/Comments |
|---------------------|--|
| Penthouse/Cab Level | No signs of water damage or visible mold growth. No unusual odors detected. A new heating, ventilation and air conditioning (HVAC) unit was recently installed in this space. The unit was indicating 50% relative humidity in the space. |
| Cab Floor Level | No signs of water damage or visible mold growth. No unusual odors detected. Inspection included opening and inspecting perimeter electrical cabinets under equipment consoles. Suspended ceiling tiles and carpet (squares) showed no visible sign of water damage. |
| Cable Access Level | No signs of water damage or visible mold growth. No unusual odors detected. The half-floor under the cab has been waterproofed. Inspection of the crawl space exterior wall was performed on this level also. |
| Junction Level | No signs of visible mold growth or unusual odors detected. In the Air Traffic Break Room (J6) several ceiling tiles were noted that had small areas of staining. Inspection above the ceiling grid revealed that the source of the staining was pipe joints that were not completely insulated, producing condensation. <i>(Please refer to photos 1, 2, and 3 in Attachment A.)</i> |
| Sub Junction Level | No signs of visible mold growth. No unusual odors detected. In room SJ4 (climate-controlled with radio communication equipment present) there is an area of staining which may be the result of drainage through a hole in the ceiling slab communicating to the floor above. <i>(Please refer to photo 4 in Attachment A.)</i> The mechanical equipment room (SJ7) has a floor drain that is functioning properly to drain condensate from the HVAC unit. |

Mr. James Burton

June 13, 2007]

Page 4

| | |
|---------------|--|
| Tenth Level | No signs of water damage or mold growth. No unusual odors detected. |
| Ninth Level | No signs of remaining water damage or active visible mold growth. No unusual odors detected. On-site contacts reported that remediation in this area was completed in March of 2005 during which drywall was removed and replaced. In some areas, spackling tape was not replaced. <i>(Please refer to photos 5 and 6 in Attachment A.)</i> The corridor area outside of the elevator door was also remediated in a similar manner. <i>(Please refer to photo 7 in Attachment A.)</i> |
| Eighth Level | No signs of water damage or visible mold growth. No unusual odors detected. |
| Seventh Level | No signs of active visible mold growth. No unusual odors detected. In one corner of room 728 the fireproofing on the ceiling (at an approximate 20-foot height) appeared to be stained. Mr. Sugent commented that this stained area has been present for some time and has not appeared to change in appearance or size over time. <i>(Please refer to photo 8 in Attachment A.)</i> |
| Sixth Level | No signs of active visible mold growth. No unusual odors detected. In one corner of room 628 the fireproofing on the ceiling appeared to be stained in a manner similar to room 728 on the 7 th level. <i>(Please refer to photo 9 in Attachment A.)</i> |
| Fifth Level | No signs of active visible mold growth. No unusual odors detected. On one side wall and in one corner of room 528 the fireproofing on the ceiling appeared to be stained (similar to the 6 th and 5 th level) in two locations. <i>(Please refer to photo 10 in Attachment A.)</i> |
| Fourth Level | No signs of remaining water damage or active visible mold growth. No unusual odors detected. On-site contacts reported that remediation in this area was completed in March of 2005 (concurrent with the 9 th level) during which drywall was removed and replaced <i>(Please refer to photos 11, 12, and 13 in Attachment A.)</i> The corridor area outside of the elevator door was also remediated in a similar manner. <i>(Please refer to photo 14 in Attachment A.)</i> |

| | |
|----------------|---|
| Third Level | No signs of remaining water damage or active visible mold growth. No unusual odors detected. On-site contacts reported that remediation in this area was completed in January of 2006 during which drywall was removed and replaced (<i>Please refer to photo 15 in Attachment A.</i>) |
| Second Level | No signs of visible mold growth. No unusual odors detected. In the Supervisor's office (base building, room 208) a ceiling tile was noted that had a small area of staining. Inspection above the ceiling grid revealed that the source of the staining was pipe joints that were not completely insulated, giving rise to condensation. (<i>Please refer to photo 17 in Attachment A.</i>) Site contacts reported past water incursion events in the security office on this level. No active water incursion was observed. |
| First Level | No signs of water damage or visible mold growth. A slight jet exhaust odor was noted. |
| Elevator Shaft | An inspection of the elevator shaft was conducted during the overnight shift. The inspection was facilitated by an elevator mechanic locking out the elevator and controlling its movement from the top of the cab. Staining and streaking of drywall (gypsum shaft liner) and concrete surfaces was apparent, most likely as result of past remediation activities involving liquid microbicide products. Inspection (by flashlight) revealed no signs of active water incursion or visible mold growth and no unusual odors were observed. (<i>Please refer to photos 18, 19, and 20 in Attachment A.</i>) In some locations within the shaft, what appeared to be residual dust and particulate matter were observed on the walls. In physically inspecting and touching these materials, they had a texture and physical appearance that was not consistent with mold growth and therefore did not appear to actually be mold. Samples of these materials were not collected for laboratory analysis per the scope of the inspection process (<i>Please refer to photo 21 in Attachment A.</i>) |

Conclusions

At the time of this survey, no visible mold growth or active sources of water incursion were observed in the ATCT and base building. No unusual odors (suggesting damp conditions) were noted in any spaces. Several ceiling tiles, having small areas of staining, were observed in interior spaces. In all of these cases, inspection above the ceiling grid revealed that the source of the staining was plumbing valves and joints giving rise to condensation. On several levels of the tower, fireproofing on the ceiling (at an approximate 20-foot height) appeared to be stained. A visual inspection of the elevator shaft (conducted from the top of the elevator cab during the overnight shift) did not reveal evidence of active water incursion nor visible mold growth.

Mr. James Burton
June 13, 2007]
Page 6

Recommendations

Based upon observations made at the Detroit ATCT during this inspection, and consistent with standard practice, Applied Environmental recommends the following:

1. Facility management personnel should remain vigilant for any new cases of water leakage or incursion events and take prompt reactive steps, should they occur, to assess and dry any affected building materials. The document: Guidance for the Management of Mold in FAA Facilities (Environmental and Occupational Safety and Health {EOSH} Services Group, September, 2006) should be consulted for appropriate guidance.
2. Mr. McClinchey noted that prompt action is taken when stained ceiling tiles are discovered. A consistent practice of promptly investigating and correcting the source of the staining, and replacing the ceiling tiles in a timely manner, should be maintained.
3. Consideration should be given to establishing a routine inspection of the elevator shaft (on at least a yearly basis) to assure that water incursion and/or mold growth is not present.

Closing

Applied Environmental, Inc. appreciates this opportunity to be of service to Lockheed Martin and the Federal Aviation Administration. If you have any questions regarding this report, or if you need further assistance, please feel free to contact me directly.

Sincerely,

David P. O'Konski, CIH, CSP
Principal

Prepared based on 6/08
assessment. Diane Morsco
developed Engineering
Package. Project
awarded.

STATEMENT OF WORK
MICROBIOLOGICAL REMEDIATION
FOR
FEDERAL AVIATION ADMINISTRATION
DETROIT METROPOLITAN WAYNE COUNTY
AIRPORT TRAFFIC CONTROL TOWER (DTW ATCT)
DETROIT, MICHIGAN

Note: The north
wall in room 1028
will be removed
rather than
cleared.

1.0 WORK SUMMARY. The Contractor is required to furnish all labor, materials, services, equipment, insurance, and perform all the work to remove and dispose of all microbiological contaminated materials (MCM) and microbiological contaminated elements (MCE) described in this Statement of Work (SOW). The Contractor shall be responsible for the cleanup and removal of moisture and microbiological contaminated gypsum board, shaft liner, and insulation in the DTW ATCT Rooms 928, 527, 527A, and 428 in accordance with the guidelines established by the New York City Department of Health entitled *Guidelines on Assessment and Remediation of Fungi in Indoor Environments* (GARFIE) attached and incorporated herein by reference (See Attachment 1). Included in the scope of work is the removal of any MCM between the bottom metal runner/track and the concrete floor; between the top metal runner/track and the structural deck; and between the metal stud and exterior concrete wall. The Contractor shall minimize dust generation and use the methodologies outlined in GARFIE for dust prevention and suppression. Prior to performing microbiological remediation procedures, the Contractor shall seal all critical penetrations and openings to the work area with a minimum of two layers of 6-mil polyethylene, and shall be responsible for ensuring adjoining areas are not exposed to the microbiological contamination during the remediation. The Contractor shall provide additional cleaning procedures and pipe insulation removal/replacement as described herein in Rooms 1028, 927, 829, 827, 728, 727, 727A, 628, 627, 529, 527, 427, 328, and 327. A complete list of the work required is included in Section 7.0 Work Procedure and the Supplemental Statement of Work (SSOW). All removals and other cleaning procedures shall be conducted at night between the hours of 6:00 PM and 6:00 AM. Negative air pressure equipment shall be equipped with a HEPA filter and discharged outside of the building whenever possible, otherwise discharged through a second HEPA filter in order to permit recirculation of air inside the building. See the SSOW for additional work required to perform the remediation work and to restore the facility.

1.1. CONTRACTOR'S RESPONSIBILITY. The Contractor shall perform all work required to give a complete and satisfactory job as required by this Statement of Work. The Contractor shall be responsible for performing this work in accordance with GARFIE. The Contractor shall perform the work per the schedule and sequence identified in the SSOW. The Contractor shall be responsible for all

debris generated under this contract at the job site and during transport of microbiological containing or contaminated materials to an approved disposal site.

1.1.1 Site Visit. The Contractor is responsible for inspecting the work space and field verifying all quantities for: constructing a negative pressure enclosure for each phase of the work, MCM, MCE removal and disposal, work area physical parameters, access limitations, and Government phasing limitations. The Contractor shall be required to work around existing furniture, fixtures and finishes during the performance of this contract. The site visit shall be scheduled by the Government for interested microbiological remediation Contractors to identify specific work area and phasing requirements.

1.1.2 Property Damage. The Contractor shall take all precautions to avoid damage to Government property or equipment. Any damage to Government property or equipment by the Contractor shall be repaired by the Contractor to its original state or better condition at no additional expense to the Government.

1.1.3 Working Conditions. Portions of the ATCT will be occupied and Government operations will continue on a normal, temporary, or restricted basis for the duration of the project. The Contractor shall take all precautions to ensure that their operations are conducted in a manner that does not interfere with the normal operations of the surrounding facilities and the safety and health of the occupants or the environment. Contractor's personnel will have limited access to the facility.

1.1.4 Cleanup. Upon completion of the work at the site, all staging and debris from the project shall be removed from the site and disposed of properly. The entire area shall be left clean and acceptable to the Government.

1.1.5 Certifications. The Contractor shall be certified by the Indoor Air Quality Association (IAQA), the Institute of Inspection, Cleaning, and Restoration (IICR), the National Duct Cleaning Association (NADCA) or equivalent.

1.2. SCHEDULE. See contract documents for duration of contract and notice to proceed.

1.2.1 Pre-Construction Meeting. The Contractor shall attend a mandatory pre-construction meeting before starting work and the Government will schedule the meeting.

1.3. TEMPORARY FACILITIES AND STAGING AREA. The electrical energy and the water consumed shall be provided by the Government at no cost to the Contractor from existing lines and sources located in the ATCT or from services adjacent to the work areas. Contractor's use of utilities shall be coordinated with the Government. Contractor is responsible for ensuring that adequate electrical power and water are available to complete the work. The Contractor will be

permitted to use the areas as directed by the Government for staging and storage of materials. The area is restricted to uncontaminated work equipment and supplies. The area shall be left clean and restored to the same condition as when accepted by the Contractor.

1.4. SUBMITTAL REQUIREMENTS. The Contractor shall submit the following additional documents prior to starting work.

- Material Safety Data Sheets for all chemical products.
- Respiratory Fit Test and Medical Surveillance for employees scheduled for this project.
- Negative Air HEPA Filtration Equipment Specification Sheet
- Proposed Phasing Schedule.

2.0 MEDICAL REQUIREMENTS. Contractor shall provide medical surveillance and have a written Respiratory Protection program in place as required by OSHA 29 CFR 1910.134 for all personnel engaged in the removal and demolition of MCM and MCE. Respirators and filters provided shall be NIOSH approved and provide the appropriate level of protection.

3.0 PROTECTIVE CLOTHING. Contractor shall provide workers and government representatives with sufficient sets of protective full body clothing. Such clothing shall consist of full body coveralls including head covers, foot covers and hand covers. Contractor shall provide additional personal protection safety equipment as required by applicable OSHA safety regulations. Contractor shall ensure that all employees who will conduct mold remediation activities are provided with, fit tested for, and trained in the correct use of personal protection equipment.

4.0 REMEDIATION AREA. Contractor shall establish a remediation area and restrict the access to the microbiological work areas during work conducted in the ATCT. Contractor shall establish a roped-off perimeter and provide warning barrier tape and signs outside the perimeter of the negative pressure enclosure system. Contractor shall establish a negative pressure enclosure system by sealing all critical penetrations or openings to the work area with a minimum of two layers of six-mil polyethylene. Negative pressure enclosures shall have a minimum of four air exchanges per hour and shall be maintained and recorded with a magnehelic guage or equivalent device under a minimum negative pressure differential of -0.02 inches of water relative to adjacent non-work area space. Negative air pressure equipment shall be equipped with a HEPA filter and exhaust shall be discharged outside the building, a minimum of 25 feet from building access points and building make-up air sources, or wherever necessary, negative air pressure equipment shall be equipped with a HEPA filter and exhaust shall be discharged through a second HEPA filter in order to permit recirculation of air inside the building. Personnel shall wear and utilize protective clothing and equipment in the remediation area as specified herein.

5.0 DECONTAMINATION AREA. Contractor shall establish a decontamination unit for passage to and from the work area during remediation operations in order to minimize the leakage of mold-contaminated dust to the outside. This unit shall consist of a minimum of

two chambers, including a clean room and equipment room separated by airlocks. The airlocks shall be formed by overlapping three sheets of 6-mil polyethylene sheeting at the exit of one room and three sheets at the entrance to the next room, with three feet of space between the barriers. Airlocks shall be constructed to effectively maintain negative pressure while not inhibiting worker egress in an emergency situation.

6.0 WORKER PROTECTION PROCEDURE.

- 6.1. Each worker and authorized visitor shall, upon entering the job site, put on appropriate respirator and clean protective clothing, before entering the work area.
- 6.2. Each worker and authorized visitor shall remove gross contamination from clothing by HEPA vacuuming, prior to leaving the remediation work area. After decontamination of protective clothing, while still wearing the respirator, remove protective clothing and dispose as microbiological waste, as appropriate, in a drum or two layers of 6-mil polyethylene disposal bags.
- 6.3. Workers shall not eat, drink, smoke, or chew gum or tobacco at the work site. Workers shall be fully protected with respirators and protective clothing immediately prior to the first disturbance of MCM or MCE and until final cleanup is completed.

7.0 WORK PROCEDURE.

- 7.1. Moisture damage restoration and mold remediation shall be conducted as necessary and as described in the Rooms 1028, 928, 927, 829, 827, 728, 727, 727A, 628, 627, 529, 527, 527A, 428, 427, 328, and 327.
- 7.2. Prior to performing microbiological remediation procedures, the Contractor shall seal all critical penetrations and openings to the work area. Establish phasing schedule with Government for each days work activity. Contractor shall HEPA-vacuum and/or wet wipe with a detergent solution all non-porous furniture and fixtures. Contractor will remove any furnishings from the remediation area, after it has been pre-cleaned. Upon completion, the Contractor will return the furnishings to the original location. If necessary, furnishings can be pre-cleaned and wrapped with two layers of 6-mil polyethylene and allowed to remain in the remediation area. Electrical equipment that poses an electrical hazard shall be HEPA vacuumed only.
- 7.3. Maintain a minimum of four air exchanges per hour within the remediation work area and a minimum negative pressure differential of -0.02 inches of water, continuously recorded by use of a magnehelic guage or equivalent device. Negative air pressure equipment shall be equipped with a HEPA filter and discharged outside of the building whenever possible, otherwise discharged through a second HEPA filter in order to permit recirculation of air inside the building. Contractor will secure entrance into the remediation area at the conclusion of each workday.

- 7.4. The walls undergoing remediation are fire rated partitions and have multiple layers of fire resistant gypsum board on each face unless otherwise indicated. Removal limits shall coincide with existing metal studs at or beyond the limits identified below. Joints between gypsum board on the surface and concealed layer shall be staggered horizontally and vertically and less than the length of gypsum board utilized. Demolition work shall be conducted utilizing methods to minimize noise and the spread of dust, such as the use of HEPA vacuums at the point of cutting and/or tools with shrouds or boots connected to a HEPA vacuum. See SSOW for additional requirements. The locations and approximate quantities for gypsum board remediation are listed below:

Gypsum board, shaft liner, and insulation totaling approximately 311 square feet will be removed from Room 928. This area includes the east (elevator shaft) wall, 8' wide to a height of 5' (surface layer), 8' wide to a height of 4'6" (concealed layer), and 8' wide to a height of 4' (shaft liner). This area includes the south (elevator shaft) wall, 10' wide to a height of 5' (surface layer), 10' wide to a height of 4'6" (concealed layer), and 10' wide to a height of 4' (shaft liner). This area includes the northwest column beam enclosure, on the north wall, 6' wide to a height of 3' (surface layer), 6' wide to a height of 2'6" (concealed layer), and 6' wide to a height of 2' (shaft liner); and on the west wall, 3' wide to a height of 3' (surface layer), 3' wide to a height of 2'6" (concealed layer), and 3' wide to a height of 2' (shaft liner). While these areas contain minimal mold contamination, it is present on multiple layers; therefore, the removal of additional quantities of gypsum board is required.

Gypsum board and insulation totaling approximately 15 square feet will be removed from Room 527. This area includes the portion of the north wall, between the east wall and the door to Room 527A, 2' wide to a height of 4' (surface layer) and 2' wide to a height of 3'6" (concealed layer).

Gypsum board and insulation totaling approximately 5 square feet will be removed from Room 527A. This area includes the portion of the south wall, between the east wall and the door to Room 527, 2' wide to a height of 18" (surface layer) and 2' wide to a height of 12" (concealed layer).

Gypsum board, shaft liner, and insulation totaling approximately 243 square feet will be removed from Room 428. This area includes the east (elevator shaft) wall, 8' wide to a height of 5' (surface layer), 8' wide to a height of 4'6" (concealed layer), and 8' wide to a height of 4' (shaft liner). This area includes the south (elevator shaft) wall, 10' wide to a height of 5' (surface layer), 10' wide to a height of 4'6" (concealed layer), and 10' wide to a height of 4' (shaft liner). While these areas contain minimal mold contamination, it is found on the inner layer; therefore, the removal of additional quantities of gypsum board is required.

- 7.5. In Rooms 928 and 428, a containment and negative pressure enclosure system shall be established as described in Section 4.0 Remediation Area. A decontamination unit shall be established as described in Section 5.0 Decontamination.
- 7.6. In Rooms 527 and 527A, a mini containment shall be established consisting of a single layer of 6-mil polyethylene sheeting but a negative pressure enclosure system is not required. Mist any contaminated areas prior to removal. Upon completion, the work area shall be HEPA vacuumed and then wet wiped with a detergent solution.
- 7.7. In Room 1028, the north wall shaft liner in its entirety shall be HEPA vacuumed and then wet wiped with an approved cleaning solution.
- 7.8. In Room 829, the portion of the east wall, between the south wall and stairwell doorframe, 2" wide to a height of 8', and the adjacent south wall, from the southeast corner westward, 1' wide to a height of 8', shall be HEPA vacuumed and then wet wiped with an approved cleaning solution.
- 7.9. In Room 728, the east (elevator shaft) wall, up to a height of 4', and the south (elevator shaft) wall, up to a height of 4', shall be HEPA vacuumed and then wet wiped with an approved cleaning solution.
- 7.10. In Room 727A, the portion of the west wall between the cable tray and the north wall, up to a height of 4', and the portion of the south wall above the door to Room 727, 3' wide to a height of 3', shall be HEPA vacuumed and then wet wiped with an approved cleaning solution.
- 7.11. In Room 628, the east (elevator shaft) wall, up to a height of 4', and the south (elevator shaft) wall, up to a height of 4', shall be HEPA vacuumed and then wet wiped with an approved cleaning solution.
- 7.12. In Room 529, the portion of the east wall, between the south wall and stairwell doorframe, 2" wide to a height of 8', shall be HEPA vacuumed and then wet wiped with an approved cleaning solution.
- 7.13. In Room 328, the east (elevator shaft) wall, up to a height of 2', and the south (elevator shaft) wall, up to a height of 2', shall be HEPA vacuumed and then wet wiped with an approved cleaning solution.
- 7.14. During cleaning procedures conducted in Rooms 1028, 829, 728, 727A, 628, 529, and 328, a mini containment shall be established consisting of a single layer of 6-mil polyethylene sheeting. A negative pressure enclosure system shall be established as described in Section 4.0 Remediation Area.
- 7.15. In Rooms 927 (approximately 4 linear feet of 11"), 827 (approximately 4 linear feet of 11"), 727 (approximately 3 linear feet of 18"), 627 (approximately 20 linear feet of 11" and 25 linear feet of 18"), 527 (approximately 4 linear feet of 11" and 25 linear feet of 18"), 427 (approximately 4 linear feet of 11" and 6 linear feet of 18"), and 327 (approximately 15 linear feet of 18"), all water stained and/or

contaminated chilled and heating water pipe insulation shall be removed and replaced.

7.16. Place MCM and MCE in a fiber/cardboard type drum or two layers of 6-mil polyethylene disposal bags with contents clearly labeled. At completion of each phase, notify the Government of completion so that Government can perform a visual inspection of the work area. Allow negative pressure system to operate a minimum of two hours after the last clean-up effort.

7.17. Upon approval of Government, remove barriers and disassemble regulated work area. Additional cleaning required in the work area because of the Government inspection shall be performed by Contractor, at no additional cost to the Government.

8.0 AIR MONITORING AND INSPECTION. The Government-retained Industrial Hygienist will determine any requirement for air monitoring, both during the remediation process and/or upon completion of the remediation process. Such area sampling will be conducted using Zefon filters and a high volume sampling pump. Procedural modifications to the decontamination procedures may be necessary at the discretion of the Government-retained Industrial Hygienist. The Government has the right to inspect the remediation work at times to be determined by the Government, but, at a minimum, once upon completed removal of contaminated materials, but before restoration materials are installed.

9.0 FINAL CLEARANCE. Acceptance of work will be dependant upon visual inspection. In areas where the gypsum board removal quantity exceeds 100 square feet, clearance air sampling shall also be conducted. The Contractor shall notify the Government when the microbiological removal is completed for each phase and the Government-retained Industrial Hygienist shall perform a thorough visual inspection of the phase within 24-hours. Clearance air sampling shall be conducted in Rooms 928 and 428. Clearance criteria shall be dependent upon the requirements stipulated in the DTW ATCT Mold Remediation Project Clearance Protocol attached and incorporated herein (See Attachment 2). All remaining rooms shall be cleared solely by visual examination.

10.0 DISPOSAL. All microbiological waste shall be disposed of at a municipal sanitary landfill. Waste bags shall not be overloaded and shall be securely sealed and stored in the designated area until disposal. Label bags, disposal containers, and truck during loading and unloading, in accordance with Federal, State and Local regulations. Contractor is responsible for removal of all materials from the Government's property.

ATTACHMENT 1

**Guidelines on Assessment and Remediation of
Fungi in Indoor Environments**

2

1

ATTACHMENT 2

DTW ATCT MOLD REMEDIATION PROJECT CLEARANCE PROTOCOL

Mold Remediation Project Clearance Protocol

PREPARED FOR:

FEDERAL AVIATION ADMINISTRATION

**Detroit Metropolitan Wayne County
Airport Traffic Control Tower
(DTW ATCT)**

DETROIT, MICHIGAN

June 13, 2008



PREPARED BY:

Barbara Hebert, CIH
NISC, KANSAS CITY ARTCC DISTRICT TSU

The **DTW ATCT Mold Remediation and Restoration Project** will include the removal of moisture and microbiological-contaminated gypsum board, shaft liner, and insulation.

After Rooms 928 and 428 have passed a thorough visual inspection, and before the outer containment barrier is removed, clearance air sampling will be performed.

Five consecutive samples will be collected inside the containment area using a high volume air sampler and Zefon Air-O-Cell® cassettes. Sampling will be conducted at a flow rate of 15 liters per minute for a period of five minutes each, resulting in a collection volume of 75 liters of air. Environmental conditions may warrant the sample collection period to be reduced to one-minute intervals, in order to reduce the collection of non-microbial particulates that can mask the presence of mold spores.

Three consecutive samples will be collected outside the containment area, but inside the ATCT in a noncomplaint area, in the same manner as above. Sampling will be conducted at a flow rate of 15 liters per minute for a period of five minutes each, resulting in a collection volume of 75 liters of air.

Three consecutive samples will be collected outside of the building, in the same manner as above. Sampling will be conducted at a flow rate of 15 liters per minute for a period of 10 minutes each, resulting in a collection volume of 150 liters of air.

For all samples collected, the high volume air sampler will be calibrated before and after use.

All samples, one lab blank, and a completed Chain of Custody form will be sent to Aerotech Laboratories, Inc., by Federal Express Priority Overnight delivery. The samples will be mailed in a rigid container or box. There is no additional temperature handling requirement.

All samples will be clearly labeled. The sample identification number appearing on the cassette **must** match the identification number shown on the Chain of Custody form. The samples will be analyzed in accordance with **Aerotech Method A001** (equivalent to the cassette manufacturer's recommended analytical procedure) via light microscopy at 600X magnification, with the entire slide (100% of the sample) being analyzed. The results will be reported as a total fungal spore count, in counts per cubic meter (counts/M³), which includes both viable and non-viable spores.

The area will be considered "clean" when the average airborne total mold spore concentration measured inside the containment area was not statistically higher than the average airborne concentration measured outside the containment area, **and** the **genus level** constituents similar for all samples taken inside the containment, inside the building (but outside of the containment) and outside of the building.

Statistical significance may be determined in the following manner:

A. All containment sample airborne total concentration levels are lower than those taken from outside the containment, or

B. The Z-test score is less than or equal to 1.65 Standard Deviations from the Mean, indicating a 90% confidence interval. The Z-test is carried out by calculating:

$$Z = \frac{Y_I - Y_O}{0.8 (1/n_I + 1/n_O)^{1/2}}$$

where Y_I is the average of the natural logarithms of the inside samples, Y_O is the average of the natural logarithms of the outside samples, n_I is the number of inside samples and n_O is the number of outside samples.

Alternative A shall be considered first, then if necessary, Alternative B. Should the calculated Z-test score exceed 1.65, the abatement area must be recleaned. An additional set of 10 samples must then be collected, as defined above, in order to establish clearance.

The **genus level** constituents will be evaluated using the Spearman Rank Order Correlation (SROC), which is a statistical technique used to test the direction and strength of the relationship between two variables. It uses the statistic "Rs", which falls between -1 and +1. If the "Rs" value is -1, there is a perfect negative correlation; between -1 and -0.5, there is a strong negative correlation; between -0.5 and 0, there is a weak negative correlation; if 0, there is no correlation; between 0 and 0.5, there is a weak positive correlation; between 0.5 and 1, there is a strong positive correlation; and if 1, there is a perfect positive correlation. Calculated "Rs" values will also be compared to the Critical Values (CV) listed in Table 13.7 of the American Conference of Governmental Industrial Hygienists "Bioaerosols: Assessment and Control", which are drawn from a standard statistical table. Comparing the "Rs" value to the CV permits a methodical acceptance or rejection. If the "Rs" value exceeds the 0.1 confidence level, the populations appear to be related or similar. If the "Rs" value is below the 0.1 confidence level, the populations do not appear to be related or are different. Should the "Rs" value be below the 0.1 confidence level, the remediation area must be recleaned unless a professional opinion can justify rank differences to be insignificant.

Once the abatement area has passed the clearance criteria, the outer containment barrier will be removed and the room will be available for restoration.

Visual inspections and clearance air sampling will be performed upon completion of the mold remediation, but prior to the re-installation of new building materials.

The visual inspection, clearance air sampling, and data interpretation will be conducted by the government-retained Industrial Hygienist.

2

2



AUS LD High Activity Design



AUS-ATCT-A05-01

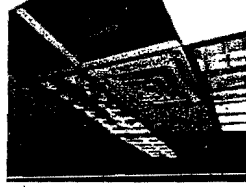

b Junction Level Ceiling Tiles Removed due to Wat...



c Dehumidifier in Junction Break Room setting on Re...



d Dead bats on same level may be source of some of...



e Equip Level paint damage apparent water running do...



f more paint damage and the only visible black spots on...

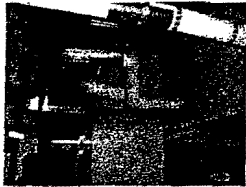

g catch trays below condensate lines on equip...

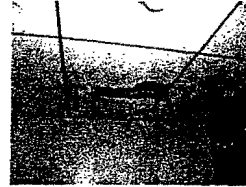

h lower floor have been extensively finished out wit...

2

3

Kansas City, Missouri Airport Traffic Control Tower (MCI ATCT)

Mold Evaluation

Completed: June 19 – September 1, 2006

Tables:

Table 1: Summary of Tape Lift Sampling Results

Table 2: Summary of Bulk Sampling Results

Attachments:

1 - Aerotech Laboratories Total Fungal Spore Tape Reports

2 - Aerotech Laboratories Total Fungal Spore Bulk Sample Reports

Introduction/Background

As identified in Standard OPS Requirement Number 0682MH572, most unoccupied areas of the MCI ATCT are unconditioned spaces and as a result, condensation or frost forms on the exterior walls at certain times of the year. This source of water was one of the contributing factors to the wetting of building materials that led to the growth of mold.

In recent months, mold has been discovered on the Sub Junction Level due to a clogged floor drain under the raised access from when water is pumped from a humidifier in the Sub Junction Equipment Room. Significant amounts of water were found under the raised floor and leaking onto the 11th and 10th Floors below and the exterior walls of the elevator shaft, as a result of the clogged floor drain. Since the walls on all of these levels are fire-rated partitions, it is likely that mold growth could be occurring on the concealed layers of the gypsum board, and a thorough and destructive investigation was needed to determine all areas of accumulated mold and potential problem areas conducive for mold growth.

During the course of the evaluation, once identified, mold quantities were estimated for future remediation. This report reflects sampling data collected from suspect materials uncovered during the investigation.

Fungal (mold) Spore Testing

Sampling Procedures

Tape lift samples were collected by direct contact using Scotchbrand® gloss finish transparent tape. Sampling was conducted under the **Cab Level** on August 15, August 24, and September 1; on the **Junction Level** on July 20 and September 1; between the **Junction** and **Sub Junction Levels** on August 24 and September 1; on the **Sub Junction Level** on June 20, June 21, July 13, and July 20; on **Level 11** on July 12, July 20, July 28, and September 1; on **Level 10** on July 11 and September 1; on **Level 6** on September 1; on **Level 4** on July 13; on **Level 3** on June 22, July 13, July 20, and July 28; and on **Ground Level** on September 1. Analysis was completed by Aerotech Laboratories, Inc.

Bulk samples were collected from drilled sheetrock paper sections or cored using Wonder Maker Environmental, Inc.® cutter sleeves. Sampling was conducted on the **Sub Junction Level** on June 20, June 21, and June 22; on **Level 11** on June 22; on **Level 10** on June 22, July 11, and July 20; on **Level 8** on July 20; on **Level 7** on July 12, July 20, and July 28; on **Level 6** on July 20; on **Level 5** on July 28; and on **Level 4** on July 28. Analysis was additionally completed by Aerotech Laboratories, Inc.

Results/Recommendations

The tape lift samples collected under the Cab Level contained mold spores at a concentration level ranging from 15 to 107 counts/cm². *Ascospores* (31 counts/cm²) were detected on the west wall, adjacent to the CA2 sign. No mycelial fragments, the actively growing assimilative phase of mold, were detected. *Ascospores* (31 counts/cm²) were detected on the east wall, south of the return air vent. No mycelial fragments were detected. *Alternaria* (15 counts/cm²) was detected on the stair stringer. Mycelial fragments represented 100% (15 out of 15) of the total concentration detected. After a detergent cleaning, *Basidiospores* (31 counts/cm²) were detected in the same area. No mycelial fragments were detected. *Alternaria* (31 counts/cm²), *Ascospores* (46 counts/cm²), *Pithomyces* (15 counts/cm²), and *Smuts* (15 counts/cm²) were detected on the west side and middle of the west stair wall. No mycelial fragments were detected. After a detergent cleaning, *Ascospores* (15 counts/cm²) were detected on the middle of the west stair wall. No mycelial fragments were detected. *Alternaria* (15 counts/cm²) was detected on the door entrance south stair stringer. No mycelial fragments were detected. HEPA-vacuuming, followed by biocide cleaning measures, will be required in the areas represented by these sample locations.

The tape lift samples collected on the Junction Level contained mold spores at a concentration level ranging from 893 to 1201 counts/cm². *Alternaria* (31 counts/cm²), *Ascospores* (15 counts/cm²), *Aspergillus* (662 counts/cm²), *Basidiospores* (31 counts/cm²), *Cladosporium* (92 counts/cm²), *Epicoccum* (15 counts/cm²), *Pithomyces* (15 counts/cm²), and *Smuts* (31 counts/cm²) were detected above the elevator door. Mycelial fragments represented only 7% (62 out of 893) of the total concentration detected. It is, however, important to note that this sample location represents an occupied area and

Aspergillus is the key component reported. Fungal disease organisms associated with environmental sources include species of *Aspergillus*, *Penicillium*, *Fusarium*, and *Stachybotrys*. Recent research has implicated many toxin-producing fungi such as these to indoor air quality problems and building-related illnesses. A number of potted plants were observed in the area. Potting soil can contain active microbes including bacteria and molds such as *Aspergillus*, therefore, may be a contributing factor to the elevated count reported. *Alternaria* (108 counts/cm²), *Ascospores* (92 counts/cm²), *Basidiospores* (31 counts/cm²), *Cladosporium* (755 counts/cm²), *Nigrospora* (31 counts/cm²), *Pithomyces* (15 counts/cm²), *Smuts* (15 counts/cm²), and *Stachybotrys* (154 counts/cm²) were detected on the top of the stairs on the top of the stair stringer. Mycelial fragments represented 5% (62 out of 1201) of the total concentration detected. Biocide cleaning measures will be required in the areas represented by these sample locations.

The tape lift samples collected between the Junction and Sub Junction Levels contained mold spores at a concentration level ranging from 46 to 2171 counts/cm². *Alternaria* (262 counts/cm²), *Aspergillus* (108 counts/cm²), *Basidiospores* (108 counts/cm²), *Bipolaris* (46 counts/cm²), *Cladosporium* (1140 counts/cm²), *Epicoccum* (108 counts/cm²), *Nigrospora* (15 counts/cm²), *Smuts* (293 counts/cm²), and *Stachybotrys* (92 counts/cm²) were detected on the gypsum wallboard cover between the stairs. Mycelial fragments represented 3% (62 out of 2171) of the total concentration detected. *Alternaria* (123 counts/cm²), *Ascospores* (31 counts/cm²), *Basidiospores* (31 counts/cm²), *Cladosporium* (108 counts/cm²), *Epicoccum* (62 counts/cm²), *Nigrospora* (15 counts/cm²), and *Smuts* (31 counts/cm²) were detected on the horizontal aluminum ledge of the window. Mycelial fragments represented 8% (31 out of 400) of the total concentration detected. *Ascospores* (31 counts/cm²) and *Epicoccum* (15 counts/cm²) were detected on the vertical aluminum ledge of the window on a water-stained patch. Mycelial fragments were below the limit of detection. *Aspergillus* (46 counts/cm²) was detected on the east wall under the window. Mycelial fragments were below the limit of detection. A significant quantity of dust was observed in this general area. Dust, when present in substantial amounts, provides a food source for mold and when a moisture source becomes available, dormant mold may start to reproduce. Microbial growth will usually continue unabated until the moisture and/or nutrient sources are removed. HEPA-vacuuming, followed by biocide cleaning measures, will be required in the areas represented by these sample locations.

The tape lift samples collected on the Sub Junction Level contained mold spores ranging from none detected to 462,000 counts/cm². *Cladosporium* (15 counts/cm²) was detected on a dark and patterned water stained area under the Fire Alarm panel, however, after biocide treatment, none was detected. *Ulocladium* (15 counts/cm²) was detected on the North wall behind the equipment racks, under the cove base, however, after biocide treatment, none was detected. *Alternaria* (15 counts/cm²), *Ascospores* (15 counts/cm²), *Bipolaris* (15 counts/cm²), *Cladosporium* (15 counts/cm²), and *Pithomyces* (15 counts/cm²) were detected above the elevator door. Mycelial fragments represented 16% (15 out of 92) of the total concentration detected. Biocide cleaning measures will be required in the area represented by this sample location. *Aspergillus* (46 counts/cm²) and *Cladosporium* (15 counts/cm²) were detected on a black spot on the ceiling by the smoke detector. No mycelial fragments were detected. After biocide treatment, none was detected. *Chaetomium* (462,000 counts/cm²), *Curvularia* (15 counts/cm²), *Stachybotrys* (216 counts/cm²) and *Ulocladium* (15 counts/cm²) were detected above the ceiling tile, on

the shaft liner, inside face. Mycelial fragments represented 83% (385,000 out of 462,246) of the total concentration detected. Remediation measures, to include drywall, gypsum board, and insulation removal, and biocide post-treatment, are required in the area represented by this sample location. No mold spore concentration levels were obtained on the yellow stain under the Fire Alarm panel and above the ceiling tile on the surface of the wall.

The tape lift samples collected on Level 11 contained mold spore concentrations ranging from none detected to 216 counts/cm². *Ulocladium* (154 counts/cm²) was detected in the 11th Floor outer ring, back of the west wall of 11TS5, on the 5th panel from the south, in an area that had been biocide treated prior to sampling. Mycelial fragments represented 10% (15 out of 154) of the total concentration detected. After subsequent re-cleaning, *Pithomyces* (31 counts/cm²) was detected in the same area. Mycelial fragments represented 48% (15 out of 31) of the total concentration detected. After a 3rd biocide cleaning, however, all mold spore concentrations were below the limit of detection. *Alternaria* (77 counts/cm²), *Ascospores* (15 counts/cm²), *Cladosporium* (31 counts/cm²), *Epicoccum* (15 counts/cm²), *Pithomyces* (31 counts/cm²), and *Smuts* (31 counts/cm²) were detected above the elevator door. The mycelial fragment concentration was below the limit of detection. Biocide cleaning measures will be required in the area represented by this sample location. *Ascospores* (15 counts/cm²) and *Cladosporium* (15 counts/cm²) were detected in the stairwell on the north wall. No mycelial fragments were detected. Biocide cleaning measures will be required in the area represented by this sample location. No mold spore concentration levels were detected on the back of the west wall of 11TS5, on the 2nd panel from the south.

The tape lift samples collected on Level 10 contained mold spores ranging from 15 to 445,953 counts/cm². *Ascospores* (15 counts/cm²) were detected in 10TS5, on the north wall under the cove base, on the back side of the 1st layer. While only a minimal concentration was detected, due to the location, remediation measures, to include drywall, gypsum board, and insulation removal and biocide post-treatment, are required in the area represented by this sample location. *Chaetomium* (445,830 counts/cm²) and *Ulocladium* (123 counts/cm²) were detected in 10TS5, on the southeast wall, on a raised colony area. Mycelial fragments represented 58% (258,258 out of 445,953) of the total concentration detected. Remediation measures, to include drywall, gypsum board, and insulation removal and biocide post-treatment, are required in the area represented by this sample location. *Alternaria* (631 counts/cm²), *Ascospores* (46 counts/cm²), *Basidiospores* (31 counts/cm²), *Cladosporium* (1294 counts/cm²), *Curvularia* (15 counts/cm²), *Epicoccum* (154 counts/cm²), *Rusts* (15 counts/cm²), and *Smuts* (46 counts/cm²) were detected in the stairwell on the south stair stringer. Mycelial fragments represented 7% (154 out of 2233) of the total concentration detected. Biocide cleaning measures will be required in the area represented by this sample location.

The tape lift sample collected on Level 6 contained a mold spore concentration of 15 counts/cm². *Basidiospores* (15 counts/cm²) were detected in the stairwell on the south wall of the landing. Mycelial fragments represented 100% (15 out of 15) of the total concentration detected. Biocide cleaning measures will be required in the area represented by this sample location.

The tape lift sample collected on Level 4 contained mold spores at a concentration level of 7361 counts/cm². *Alternaria* (231 counts/cm²), *Ascospores* (92 counts/cm²), *Aspergillus* (477 counts/cm²), *Basidiospores* (231 counts/cm²), *Chaetomium* (5914 counts/cm²), *Pithomyces* (108 counts/cm²), and *Smuts* (308 counts/cm²) were detected in 4TS3, in the northeast corner under the covebase. Mycelial fragments represented only 8% (585 out of 7361) of the total concentration detected, however, remediation measures, to include removal of cove base and biocide post-treatment, are required in the area represented by this sample location.

The tape lift samples collected on Level 3 contained mold spore concentrations ranging from none detected to 9733 counts/cm². *Alternaria* (231 counts/cm²), *Aspergillus* (77 counts/cm²), *Cladosporium* (9240 counts/cm²), *Nigrospora* (31 counts/cm²), *Pithomyces* (62 counts/cm²), *Smuts* (77 counts/cm²) and *Ulocladium* (15 counts/cm²) were detected in 3TS1, on the south wall along the ceiling, directly across from the elevator door. Mycelial fragments represented only 3% (323 out of 9733) of the total concentration detected. After biocide cleaning, *Cladosporium* (15 counts/cm²) was detected in the same location, however, no mold spore concentration levels were detected after a 2nd biocide cleaning treatment. *Aspergillus* (678 counts/cm²), *Basidiospores* (15 counts/cm²), and *Cladosporium* (31 counts/cm²) were detected in 3TS1, on the ceiling above the Fire Alarm horn, however, after biocide treatment, none was detected. *Alternaria* (62 counts/cm²), *Aspergillus* (92 counts/cm²), *Basidiospores* (462 counts/cm²), *Chaetomium* (15 counts/cm²), *Cladosporium* (3034 counts/cm²), *Curvularia* (15 counts/cm²), *Pithomyces* (62 counts/cm²), and *Smuts* (46 counts/cm²) were detected in 3TS1, above the door to 3TS3. Mycelial fragments represented only 6% (231 out of 3788) of the total concentration detected. Biocide cleaning measures will be required in the area represented by this sample location. No mold spore concentration levels were detected in 3TS1, on the west end of the south wall, near the ceiling hatch. This area received two biocide treatments, but had not been previously tested. No mold spore concentration levels were detected in 3TS4 on the north wall.

The tape lift sample collected on Ground level contained a mold spore concentration level of 92 counts/cm². *Alternaria* (15 counts/cm²), *Basidiospores* (15 counts/cm²), *Cladosporium* (46 counts/cm²), and *Pithomyces* (62 counts/cm²) were detected on the gypsum wallboard cover between the stairs. Mycelial fragments represented 16% (15 out of 92) of the total concentration detected. Biocide cleaning measures will be required in the area represented by this sample location.

A summary of tape lift sampling results is shown in Table 1.

The bulk samples collected on the Sub Junction Level and Level 11 (Room 11TS5) contained mold spore concentrations below the limit of detection. The bulk samples collected in the 11th Floor Outer Ring contained mold spores ranging from 19,259 to 1,025,800 counts/gram. *Alternaria* (1481 counts/gram), *Aspergillus* (4444 counts/gram), *Cladosporium* (2963 counts/gram), *Pithomyces* (2963 counts/gram), *Smuts* (2963 counts/gram) and *Ulocladium* (4444 counts/gram) were detected in the northeast void. *Aspergillus* (947,600 counts/gram), *Cladosporium* (9200 counts/gram), *Epicoccum* (13,800 counts/gram), *Pithomyces* (4600 counts/gram), *Smuts* (13,800 counts/gram) and *Ulocladium* (27,600 counts/gram) were detected in the west void. Mycelial fragments

were below the limit of detection. This insulation, which serves as a smoke barrier, must be removed and replaced.

The bulk samples collected on Level 10 contained mold spores ranging from none detected to 2222 counts/gram. *Aspergillus* (2222 counts/gram) was detected in 10T5, on the north wall under the cove base, on the back side of the 1st layer. The mycelial fragment concentration was below the limit of detection, indicating a dormant or non-germinating stage. Due to the location of the contamination detected, however, remediation measures, to include drywall, gypsum board, and insulation removal and biocide post-treatment, are required in the area represented by this sample location.

The bulk sample collected on Level 8 contained mold spore concentrations below the limit of detection.

The bulk samples collected on Level 7 contained mold spores ranging from none detected to 3704 counts/gram. *Aspergillus* (3704 counts/gram) was detected in 7T5, in a yellowed fireproofing sample. The mycelial fragments were below the limit of detection. Similar yellowed fireproofing samples were collected in 7T5 in the center of the room; in 7T5 at the ceiling level; in 7T5 on the metal deck; in 7T5 on the west side of the elevator shaft; in 7T5 on the middle of the beam on the north side of the elevator shaft; in 7T1 above the west access panel; and in 7T4 on the lower beam, on the west side of the elevator. All contained mold spore concentrations below the limit of detection.

The bulk sample collected on Level 6 contained mold spore concentrations below the limit of detection.

The bulk sample collected on Level 5 contained mold spore concentrations below the limit of detection.

The bulk samples collected on Level 4 contained mold spore concentrations below the limit of detection.

A summary of the bulk sampling results is shown in Table 2.

Table 1: Summary of Tape Lift Sampling Results

| Location | Date Sampled | Spore Count (Counts/cm ²) | Genus Level Constituent |
|--|--------------|---|--|
| Under Cab Level, west side of west stair wall | 8/15/2006 | 15 | <i>Smuts</i> |
| Under Cab Level, stair stringer | 8/15/2006 | 15 | <i>Alternaria</i> |
| Under Cab Level, stair stringer (Detergent treated) | 9/1/2006 | 31 | <i>Basidiospores</i> |
| Under Cab Level, CA2 Landing, west wall | 8/24/2006 | 31 | <i>Ascospores</i> |
| Under Cab Level, middle of west stair wall | 8/24/2006 | 31 46 15 15 | <i>Alternaria</i> <i>Ascospores</i> <i>Pithomyces</i> <i>Smuts</i> |
| Under Cab Level, middle of west stair wall (Detergent treated) | 9/1/2006 | 15 | <i>Ascospores</i> |
| Under Cab Level, east wall, south of return air vent | 8/24/2006 | 31 | <i>Ascospores</i> |
| By Door to Cab Level, south stair stringer | 9/1/2006 | 15 | <i>Alternaria</i> |
| Junction Level, above elevator door | 7/20/2006 | 31 15 662 31 92 15 15 31 | <i>Alternaria</i> <i>Ascospores</i> <i>Aspergillus</i> <i>Basidiospores</i> <i>Cladosporium</i> <i>Epicoccum</i> <i>Pithomyces</i> <i>Smuts</i> |
| Junction Level, top of stairs, top of stair stringer | 9/1/2006 | 108 92 31 755 31 15 15 154 | <i>Alternaria</i> <i>Ascospores</i> <i>Basidiospores</i> <i>Cladosporium</i> <i>Nigrospora</i> <i>Pithomyces</i> <i>Smuts</i> <i>Stachybotrys</i> |
| Between Junction and Sub Junction Levels, on the gypsum wallboard cover between stairs | 8/24/2006 | 262 108 108 46 1140 108 15 293 92 | <i>Alternaria</i> <i>Aspergillus</i> <i>Basidiospores</i> <i>Bipolaris</i> <i>Cladosporium</i> <i>Epicoccum</i> <i>Nigrospora</i> <i>Smuts</i> <i>Stachybotrys</i> |

| | | | |
|---|-----------|--|--|
| Between Junction and Sub Junction Levels, on horizontal aluminum ledge of window | 9/1/2006 | 123 31 31 108 62 15 31 | <i>Alternaria</i> <i>Ascospores</i> <i>Basidiospores</i> <i>Cladosporium</i> <i>Epicoccum</i> <i>Nigrospora</i> <i>Smuts</i> |
| Between Junction and Sub Junction Levels, on vertical aluminum ledge of window w/ water stain | 9/1/2006 | 31 15 | <i>Ascospores</i> <i>Epicoccum</i> |
| Between Junction and Sub Junction Levels, east wall under window | 9/1/2006 | 46 | <i>Aspergillus</i> |
| Sub Junction, stairwell landing, black spot on ceiling by smoke detector | 8/24/2006 | (Tape could not be analyzed) | |
| Sub Junction, stairwell landing, black spot on ceiling by smoke detector | 9/1/2006 | 46 15 | <i>Aspergillus</i> <i>Cladosporium</i> |
| Sub Junction, stairwell landing, black spot on ceiling by smoke detector (Biocide treated) | 1/11/07 | None Detected | |
| Sub Junction Level, yellow stain, under Fire Alarm panel | 6/20/2006 | None Detected | |
| Sub Junction Level, black patterned area, under Fire Alarm panel | 6/20/2006 | 15 | <i>Cladosporium</i> |
| Sub Junction Level, above ceiling tile, surface of wall | 6/21/2006 | None Detected | |
| Sub Junction Level, above ceiling tile, shaft liner, inside face | 6/21/2006 | 462,000 15 216 15 | <i>Chaetomium</i> <i>Curvularia</i> <i>Stachybotrys</i> <i>Ulocladium</i> |
| Sub Junction Level, north wall behind equipment racks, under cove base | 6/21/2006 | 15 | <i>Ulocladium</i> |
| Sub Junction Level, under Fire Alarm panel (Biocide treated) | 7/13/2006 | None Detected | |
| Sub Junction Level, north wall behind equipment racks, under cove base (Biocide treated) | 7/13/2006 | None Detected | |
| Sub Junction Level, above elevator door | 7/20/2006 | 15 15 15 15 15 | <i>Alternaria</i> <i>Ascospores</i> <i>Bipolaris</i> <i>Cladosporium</i> <i>Pithomyces</i> |
| 11 th Floor outer ring, back of west wall of 11TS5, 5 th panel from south (Biocide treated – 1 st treatment) | 7/12/2006 | 154 | <i>Ulocladium</i> |

| | | | |
|---|-----------|--|--|
| 11 th Floor outer ring, back of west wall of 11TS5, 5 th panel from south (Biocide treated – 2 nd treatment) | 7/20/2006 | 31 | <i>Pithomyces</i> |
| 11 th Floor outer ring, back of west wall of 11TS5, 5 th panel from south (Biocide treated – 3 rd treatment) | 7/28/2006 | None Detected | |
| 11 th Floor outer ring, back of west wall of 11TS5, 2 nd panel from south (no visible mold) | 7/28/2006 | None Detected | |
| 11 th Floor, above elevator door | 7/20/2006 | 77 15 31 15 31 31 | <i>Alternaria</i> <i>Ascospores</i> <i>Cladosporium</i> <i>Epicoccum</i> <i>Pithomyces</i> <i>Smuts</i> |
| 11 th Floor, stairwell, north wall | 9/1/2006 | 15 15 | <i>Ascospores</i> <i>Cladosporium</i> |
| 10TS5, southeast wall, raised colonies | 7/11/2006 | 445,830 123 | <i>Chaetomium</i> <i>Ulocladium</i> |
| 10TS5, north wall under cove base, back side of 1 st layer | 7/11/2006 | 15 | <i>Ascospores</i> |
| 10 th Floor, stairwell, south stair stringer | 9/1/2006 | 631 46 31 1294 15 154 15 46 | <i>Alternaria</i> <i>Ascospores</i> <i>Basidiospores</i> <i>Cladosporium</i> <i>Curvularia</i> <i>Epicoccum</i> <i>Rusts</i> <i>Smuts</i> |
| Landing below 6 th Floor, stairwell, south wall | 9/1/2006 | 15 | <i>Basidiospores</i> |
| 4TS3, northeast corner under cove base | 7/13/2006 | 231 92 477 231 5914 108 308 | <i>Alternaria</i> <i>Ascospores</i> <i>Aspergillus</i> <i>Basidiospores</i> <i>Chaetomium</i> <i>Pithomyces</i> <i>Smuts</i> |
| 3TS1, south wall along ceiling, directly across from elevator door | 7/13/2006 | 231 77 9240 31 62 77 15 | <i>Alternaria</i> <i>Aspergillus</i> <i>Cladosporium</i> <i>Nigrospora</i> <i>Pithomyces</i> <i>Smuts</i> <i>Ulocladium</i> |
| 3TS1, on ceiling above Fire Alarm horn | 7/13/2006 | 678 15 31 | <i>Aspergillus</i> <i>Basidiospores</i> <i>Cladosporium</i> |

| | | | |
|--|-----------|---|---|
| 3TS1, above door to 3TS3 | 7/13/2006 | 62 92 462 15 3034 15 62 46 | <i>Alternaria</i> <i>Aspergillus</i> <i>Basidiospores</i> <i>Chaetomium</i> <i>Cladosporium</i> <i>Curvularia</i> <i>Pithomyces</i> <i>Smuts</i> |
| 3TS4, north wall | 6/22/2006 | None Detected | |
| 3TS1, south wall along ceiling, directly across from elevator door (Biocide treated) | 7/20/2006 | 15 | <i>Cladosporium</i> |
| 3TS1, on ceiling above Fire Alarm horn (Biocide treated) | 7/20/2006 | None Detected | |
| 3TS1, south wall on west end near ceiling hatch (Biocide treated) | 7/28/2006 | None Detected | |
| 3TS1, south wall along ceiling, directly across from elevator door (Biocide treated – 2 nd treatment) | 7/28/2006 | None Detected | |
| G5, on the gypsum wallboard cover between stairs | 9/1/2006 | 15 15 46 15 | <i>Alternaria</i> <i>Basidiospores</i> <i>Cladosporium</i> <i>Pithomyces</i> |

Table 2: Summary of Bulk Sampling Results

| Location | Date Sampled | Spore Count (Counts/gram) | Genus Level Constituent |
|---|--------------|--|---|
| Sub Junction Level, yellow stain, under Fire Alarm panel | 6/20/2006 | None Detected | |
| Sub Junction Level, north wall behind equipment racks, under cove base | 6/21/2006 | None Detected | |
| Sub Junction 3 Shop, south wall | 6/21/2006 | None Detected | |
| Sub Junction, northwest wall, under cove base | 6/22/2006 | None Detected | |
| 11TS5, Fireproofing (normal appearance) | 6/22/2006 | None Detected | |
| 11 th Floor Outer Ring, northeast void | 12/29/2006 | 1481 4444 2963 2963 2963 4444 | <i>Alternaria</i> <i>Aspergillus/</i> <i>Penicillium</i> <i>Cladosporium</i> <i>Pithomyces</i> <i>Smuts</i> <i>Ulocladium</i> |
| 11 th Floor Outer Ring, west void | 12/29/2006 | 947,600 9200 13,800 4600 13.800 27600 | <i>Aspergillus/</i> <i>Penicillium</i> <i>Cladosporium</i> <i>Epicoccum</i> <i>Pithomyces</i> <i>Smuts</i> <i>Ulocladium</i> |
| 10TS5, Fireproofing (normal appearance) | 6/22/2006 | None Detected | |
| 10TS5, Metal deck fireproofing, north side of elevator shaft (yellow appearance) | 7/20/2006 | None Detected | |
| 10TS5, steel beam fireproofing, west side of elevator shaft (yellow brown appearance) | 7/20/2006 | None Detected | |
| 10TS5, paper from exposed layer of gypsum board, south wall elevator shaft, 9' above floor finishes | 7/20/2006 | None Detected | |
| 10TS5, north wall under cove base, back side of 1 st layer | 7/11/2006 | 2222 | <i>Aspergillus/</i> <i>Penicillium</i> |
| 8TS3, beam fireproofing, southeast corner (yellow brown appearance) | 7/20/2006 | None Detected | |
| 7TS5, fireproofing (yellow appearance) | 7/12/2006 | 3704 | <i>Aspergillus/</i> <i>Penicillium</i> |
| 7TS5, beam fireproofing in center of room (yellow appearance) | 7/20/2006 | None Detected | |

| | | | |
|---|-----------|---------------|--|
| 7TS5, beam fireproofing at ceiling level (yellow appearance) | 7/20/2006 | None Detected | |
| 7TS5, metal deck fireproofing (yellow appearance) | 7/20/2006 | None Detected | |
| 7TS5, beam fireproofing, west side of elevator shaft (yellow appearance) | 7/28/2006 | None Detected | |
| 7TS5, middle of beam fireproofing, north side of elevator shaft (yellow appearance) | 7/28/2006 | None Detected | |
| 7TS1, beam fireproofing above west access panel (yellow appearance) | 7/20/2006 | None Detected | |
| 7TS4, fireproofing along north wall (yellow brown appearance) | 7/20/2006 | None Detected | |
| 6TS5, lower beam fireproofing, west side of elevator (light yellow appearance) | 7/20/2006 | None Detected | |
| 5TS5, middle of beam fireproofing, south wall, north side of elevator shaft (yellow appearance) | 7/28/2006 | None Detected | |
| 4TS4, fireproofing on north wall (white stained appearance) | 7/28/2006 | None Detected | |
| 4TS5, deck fireproofing, northwest wall (yellow, brown and white appearance) | 7/28/2006 | None Detected | |
| 4TS5, fireproofing on west wall (yellow and white appearance) | 7/28/2006 | None Detected | |

24

Kansas City, Missouri Airport Traffic Control Tower (MCI ATCT)

Post Mold Remediation Clearance Report

Performed: October 3 - November 2, 2007

Report Prepared by: Barbara Hebert, NISC CIH

Tables:

- Table 1: Summary of Mean Clearance Concentrations
- Table 2: Summary of Confidence Level Critical Values
- Table 3: Summary of Spearman Rank Order Correlation Values and Confidence Level Critical Values

Attachments:

- 1 - Aerotech Laboratories Total Fungal Spore Air Analysis Reports
- 2 - Aerotech Laboratories Total Fungal Spore Bulk and Tape Analysis Report
- 3 - Spearman Rank Order Correlation Calculations

Introduction

On October 2, 2007, B&R Insulation, Incorporated, initiated remediation of water-stained and mold-contaminated gypsum board, shaft liner, insulation, and pipe insulation in the Kansas City Airport Traffic Control Tower (MCI ATCT), in accordance with Specification FAA-ACE 472-169 and the guidelines established by the New York City Department of Health for the Assessment and Remediation of Fungi in Indoor Environments. Rooms were considered "clean" when: 1) a visual inspection of the work area was performed and passed; 2) air monitoring results were acceptable (only performed when remediation exceeded 100 square feet); and 3) there was no evidence of contamination. The work area and data discrepancies were evaluated by professionals and advice/direction was given to address the issues.

After Rooms 10TS5, 11TS5, SJ1, and 3TS5 passed a visual inspection, clearance air sampling was performed as specified in the **MCI ATCT Mold Remediation Project Clearance Protocol (MCI ATCT MRPCP)**, based on the size of the area impacted by mold contamination, that exceeded 100 square feet.

Air sampling was conducted using a Zefon Mini-Pump and Air-O-Cell® cassettes. The Zefon pump provides a continuous 15 liters per minute flow rate and is designed for exclusive use with Air-O-Cell® cassettes. The Zefon pump was calibrated before and after each sampling period with a Zefon Air-O-Cell calibrator. Analysis of all samples was completed by Aerotech Laboratories, Incorporated, a laboratory accredited by the American Industrial Hygiene Association's Environmental Microbiology Laboratory Accreditation Program (EMLAP).

Air-O-Cell® cassettes are designed for rapid collection and analysis of a wide range of airborne particulates, such as mold spores, pollen, skin cell fragments, and inorganic particulates. The design of the airflow pathway creates a deposition of particles onto the glass slide contained in the cassette housing. After sampling, the glass slides are removed and analyzed by direct microscopic analysis at 600X magnification. This method does not differentiate between viable and non-viable spores, therefore, a total count is reported.

Sampling intervals varied between five and ten minutes for the outside samples and between one and five minutes for the non-complaint area and containment samples. The sampling intervals were varied, dependent upon environmental conditions, in order to reduce the collection of non-microbial particulates that can mask the presence of mold spores and bias the numbers reported. Included with the cassette, on the laboratory Chain of Custody form, was the volume of air sampled, based on the flowrate and duration of sampling. Counts per cubic meter of air were then determined, thus allowing for a direct comparison of all samples collected (outside, non-complaint area, and containment).

In Rooms 10TS5, 11TS5, SJ1, and 3TS5, three samples were collected from the outside air (o), three samples were collected from a non-complaint area (n), and five

samples were collected from the containment (c). A respective mean concentration was determined for the "o, n, and c".

Air monitoring results were within acceptable ranges when the average airborne total mold spore concentration measured inside the containment area was not statistically higher than the average airborne concentration measured outside the containment area, **and the genus level** constituents similar for all samples taken inside the containment, inside the building (but outside of the containment) and outside of the building. Discrepancies were reviewed and addressed on a case-by-case basis.

Statistical significance may be determined in the following manner:

A. All containment sample airborne total concentration levels are lower than those taken from outside the containment, or

B. The Z-test score is less than or equal to 1.65 Standard Deviations from the Mean, indicating a 90% confidence interval. The Z-test is carried out by calculating:

$$Z = \frac{Y_I - Y_O}{0.8 (1/n_I + 1/n_O)^{1/2}}$$

where Y_I is the average of the natural logarithms of the inside samples, Y_O is the average of the natural logarithms of the outside samples, n_I is the number of inside samples and n_O is the number of outside samples.

The **genus level** constituents were evaluated using the Spearman Rank Order Correlation (SROC), which is a statistical technique used to test the direction and strength of the relationship between two variables. It uses the statistic "Rs", which falls between -1 and +1. If the "Rs" value is -1, there is a perfect negative correlation; between -1 and -0.5, there is a strong negative correlation; between -0.5 and 0, there is a weak negative correlation; if 0, there is no correlation; between 0 and 0.5, there is a weak positive correlation; between 0.5 and 1, there is a strong positive correlation; and if 1, there is a perfect positive correlation. Use of the Spearman Rank Order Correlation test is described in Chapter 13, Data Analysis, of "Bioaerosols: Assessment and Control" (BAC), published by the American Conference of Governmental Industrial Hygienists (ACGIH) in 1999. Calculated "Rs" values can also be compared to the Critical Values (CV) listed in Table 13.7 of BAC, which are drawn from a standard statistical table. Comparing the "Rs" to the CV permits a methodical acceptance, or rejection, of this portion of the project completion criteria. This is commonly done at the $p = 0.1$ or $p = 0.05$ confidence level. If the "Rs" value exceeds the 0.1 confidence level, the populations appear to be related or appear similar. If the "Rs" value is below the 0.1 confidence level, the populations do not appear to be related or appear different.

The rank-order test indicates the confidence with which one can say that two samples differ or are similar, however, the results do not assess the importance of any differences that may be statistically significant such as variations at the species level that

may produce different health effects, rank differences that may be judged significant based on very low concentrations, and other examples as well.

In Rooms 10TS5, 11TS5, SJ1, and 3TS5, respective "Rs" values were determined when comparing the outside samples versus the containment samples, as well as the non-complaint area samples versus the containment samples. The "Rs" values were then compared to the CV to permit a methodical acceptance or rejection.

Although some areas passed via visual inspection and/or air monitoring, a decision was reached to re-inspect or re-clean an area. This was based on a professional opinion that circumstances warranted further consideration based on knowledge and experience from similar mold remediation projects.

The overall results, as determined by air monitoring and/or visual examination, are summarized in the following section of this report.

Results

Room 10TS5 - Cleared and released for restoration on 10/5/07. The mean containment concentration (195 counts per cubic meter) was significantly below the mean outside concentration (2273 counts per cubic meter) and below the mean non-complaint area concentration (427 counts per cubic meter). By SROC, there was a weak positive correlation when comparing the outside samples versus containment samples ($R_s = 0.30$) and non-complaint area samples versus containment samples ($R_s = 0.23$). Both R_s values were below the 0.1 confidence level (0.3260 and 0.4182), therefore, the populations appear different. The mean containment concentration was, however, very low, and the samples contained only six types of mold. The non-complaint area samples contained nine types of mold, while the outside samples contained 17 types of mold. As indicated by the BAC, rank differences based on very low concentrations may be due to chance variation, therefore, in this example, were not judged to be significant.

Both the containment area location and the non-complaint area location are non-occupied areas.

Room 11TS5 - Cleared and released for restoration on 10/10/07. The mean containment concentration (438 counts per cubic meter) was below the mean outside concentration (2827 counts per cubic meter) but above the mean non-complaint area concentration (31 counts per cubic meter). By SROC, there was a weak positive correlation when comparing the outside samples versus containment samples ($R_s = 0.46$) and a strong positive correlation when comparing the non-complaint area samples versus containment samples ($R_s = 0.69$). Both R_s values were above the 0.1 confidence level (0.3791 and 0.4182), therefore, the populations appear similar.

The final containment mean concentration was higher than expected and above the non-complaint area mean concentration, therefore, the area was re-inspected. Although visually clean, a small breach/gap was discovered in the southwest corner of

the room, near the floor, where a beam and the shaft liner meet. This gap was caused by the removal of the concealed layer of gypsum board that occurred during the remediation process. It was apparent that air from an outside source was being drawn into the containment by the negative air machine.

The gap was sealed with firestop caulk. As a precaution, the room was thoroughly re-cleaned, and the air was scrubbed for an additional three hours, prior to release for restoration.

Both the containment area location and the non-complaint area location are non-occupied areas.

Room SJ1 - Cleared and released for restoration on 10/11/07. The mean containment concentration (33 counts per cubic meter) was significantly below the mean outside concentration (5487 counts per cubic meter) and below the mean non-complaint area concentration (44 counts per cubic meter). By SROC, there was a strong positive correlation when comparing the outside samples versus containment samples ($R_s = 0.74$) and non-complaint area samples versus containment samples ($R_s = 0.98$). Both R_s values were above the 0.1 confidence level (0.3382 and 0.7000), therefore, the populations appear similar.

Room SJ1 failed to meet the initial clearance requirements on 10/9/07. Excessively high background debris concentrations in the containment samples rendered the data questionable. SJ1 was re-cleaned and re-tested and passed favorably on 10/11/07.

Both the containment area location and the non-complaint area location are occupied areas. Room SJ1 houses ASDE/AMASS equipment, TDWR DFU equipment, and Multiple PCS and Radio Receiver equipment.

Room 3TS5 - Cleared and released for restoration on 10/24/07. The mean containment concentration (1563 counts per cubic meter) was below the mean outside concentration (7614 counts per cubic meter) but above the mean non-complaint area concentration (35 counts per cubic meter). The calculated Z-test score (-2.84) met the criteria specified in the MCI ATCT MRPCP. By SROC, there was a strong positive correlation when comparing the outside samples versus containment samples ($R_s = 0.85$) and a weak positive correlation when comparing the non-complaint area samples versus containment samples ($R_s = 0.22$). The R_s value for the outside samples versus containment samples was above the 0.1 confidence level (0.3626), therefore, the populations appear similar. The R_s value for the non-complaint area samples versus containment samples was below the 0.1 confidence level (0.3791), therefore, the populations appear different.

The containment clearance testing results obtained on 10/19/07 were higher than expected, therefore, the room was re-evaluated and a number of findings were noted.

Room 3TSS5 contains fire suppression equipment and is unique in many ways. In order to moisturize the seals on the centrifugal water pumps, which are used to pressurize the sprinkler system in time of a fire, a trickle of water is continuously fed to the pumps, which empties into a reservoir. Once the depth in the reservoir reaches a certain level, the water will then drain out. Since standing water is normally present, it may potentially serve as an amplification site for mold. An additional section of shaft liner was removed and the reservoir basins were covered.

The west, north, and a portion of the east wall have block foam insulation panels located between the precast wall and unfinished gypsum board. During the remediation process, the gypsum board had been removed at the four foot level, exposing the foam blocks beneath. During the re-inspection process, after removing and evaluating the blocks, water was observed running down the wall directly below a humidity sensor panel. Closer inspection determined that outside air was entering the room from a gap where the sensor was attached to the wall. The problem was reported and the gap was re-caulked. Had it not have been raining on that particular day, water would not have been seen, and the gap would not have been noticed.

The entire Room 3TSS5 was re-cleaned and re-tested. While the mean containment concentration still had not significantly changed, it was below the mean outside concentration, and the calculated Z-test score met the criteria specified in the MCI ATCT MRPCP. A strong positive correlation value was obtained by SROC, when comparing outside air constituents to the containment constituents, indicating their similarities. The containment was released for restoration on 10/24/07.

At a later time during that day, while performing a visual assessment of the entire elevator shaft, a gap was observed where the additional section of shaft liner had been removed and replaced. It was apparent that additional outside air was being drawn into Room 3TSS5, from the elevator shaft, by the negative air machine, that had been running during the time of re-testing. This finding was supported by the strong positive correlation value obtained by SROC, as described above.

Both the containment area location and the non-complaint area location are non-occupied areas.

The mean clearance concentrations, confidence level critical values, and SROC values are summarized in Tables 1, 2, and 3, respectively.

The Spearman Rank Order Correlation calculations are presented in Attachment 3.

Numerous other rooms were solely cleared by visual examination. The clearance dates were as follows:

Room 10TS4 - Approximately 33 square feet was removed. The room was cleared and released for restoration on 10/03/07.

Room 11TS6 - Approximately 18 square feet was removed. The room was cleared and released for restoration on 10/05/07.

Cab Level Stairs - Approximately 20 square feet was removed. The area was cleared and released for restoration on 10/07/07.

Cab Level Walkway Door - Approximately four square feet was removed. The area was cleared and released for restoration on 10/07/07.

Room SJ1 north and east walls - Three access panels were cut and framed on the north and east walls of this room to serve as a means of evaluating the concealed shaft liner behind the walls. These areas were evaluated on 10/08/07 and no mold was found.

Room G4 - Approximately 14 square feet was removed. The room was cleared and released for restoration on 10/09/07.

Room 2TS5 - Approximately 13 square feet was removed. The room was cleared and released for restoration on 10/10/07.

11th Floor Outer Ring - All gypsum board scraps, debris, and fire safing insulation was removed. The area was cleared and released for restoration on 10/11/07.

Room 8TS1 - Approximately 39 square feet was removed above the ceiling in the southwest corner of the room. This area was cleared and released for restoration on 10/17/07. See additional discussion concerning this room in the **Room 8TS5** paragraph below.

Room 8TS6 - Approximately 40 square feet was removed. The room was cleared and released for restoration on 10/17/07.

Room SJ1 east wall (modification added to current contract on 10/2/07) - Approximately 8 square feet was removed. The area was cleared and released for restoration on 10/17/07.

Room 8TS5 - Based upon a decision made by the Project Engineer, an opening was made on the south wall of this room, centered approximately 13'6" above floor finish, to coincide with the location of the mold found on the outside of the elevator shaft liner panel during the initial inspection of the facility. The source of this mold was due to a blocked humidifier floor drain that was additionally the source of the problems found in other areas of the facility. The purpose for creating this opening was to be able to evaluate the concealed face of the shaft liner panel and the concealed layer of 5/8" gypsum board on the opposite side of the wall. This wall is a fire rated partition, therefore, in order to access and determine the amount of contaminated material on the elevator shaft liner, it was necessary to first remove two layers of 5/8" gypsum board. While minimal contamination was found on the middle layer of gypsum board,

approximately 37 square feet of contaminated shaft liner was found and removed on the south and east walls of Room 8TS5. An additional 20 square feet of contaminated shaft liner was found and removed on the north wall of the adjacent Room 8TS1. Room 8TS5 and the north wall of Room 8TS1 were cleared and released for restoration on 10/18/07.

Room 4TS3 - Approximately 11 square feet was removed. The room was cleared and released for restoration on 10/18/07.

Room 3TS3 - Approximately 77 square feet was removed. The room was cleared and released for restoration on 10/18/07.

Room 9TS5 - This room was similarly evaluated as was Room 8TS5, in order to determine any possible contamination on the concealed face of the elevator shaft liner. While minimal contamination was found on the middle layer of gypsum board, approximately 22 square feet of contaminated shaft liner was found and removed on the south wall. The room was cleared and released for restoration on 10/19/07.

Room 7TS5 - This room was similarly evaluated on 10/19/07, as was Room 8TS5, in order to determine any possible contamination on the concealed face of the elevator shaft liner. No mold was found.

Room J10 (modification added to current contract on 10/2/07) - Approximately 7 square feet was removed. The area was cleared and released for restoration on 10/22/07.

10th Floor Stairwell - An access panel was cut and framed on the south wall of the stairwell to serve as a means of evaluating the concealed spaces behind the stairwell. The area was evaluated on 10/29/07 and no mold was found.

7th Floor Stairwell - An access panel was cut and framed on the south wall of the stairwell to serve as a means of evaluating the concealed spaces behind the stairwell. The area was evaluated on 10/29/07 and no mold was found.

9th Floor Stairwell - An access panel was cut and framed on the south wall of the stairwell to serve as a means of evaluating the concealed spaces behind the stairwell. Suspect black spots were found all along the stairway wall that appeared to penetrate the gypsum board. A bulk sample was collected and analyzed on 10/30/07 and it did not contain mold.

6th Floor Stairwell - An access panel was cut and framed on the south wall of the stairwell to serve as a means of evaluating the concealed spaces behind the stairwell. The area was evaluated on 10/30/07 and no mold was found.

5th Floor Stairwell - An access panel was cut and framed on the south wall of the stairwell to serve as a means of evaluating the concealed spaces behind the stairwell. The area was evaluated on 10/30/07 and no mold was found.

4th Floor Stairwell - An access panel was cut and framed on the south wall of the stairwell to serve as a means of evaluating the concealed spaces behind the stairwell. The area was evaluated on 10/30/07 and no mold was found.

3rd Floor Stairwell - An access panel was cut and framed on the south wall of the stairwell to serve as a means of evaluating the concealed spaces behind the stairwell. The area was evaluated on 10/30/07 and no mold was found.

2nd Floor Stairwell - An access panel was cut and framed on the south wall of the stairwell to serve as a means of evaluating the concealed spaces behind the stairwell. A black and white substance, approximately 2" by 3" in size, was found on the middle panel of gypsum board. Two tape samples were collected and analyzed on 10/30/07 and mold was found. The spot and surrounding area were cleaned with detergent solution on 10/30/07 and re-cleaned on 11/1/07.

Ground Floor Stairwell - An access panel was cut and framed on the south wall of the stairwell to serve as a means of evaluating the concealed spaces behind the stairwell. Although minimal mold was found, approximately 228 square feet of multiple layers of 5/8" gypsum board and shaft liner were removed from the east stairway wall. The area was cleared and released for restoration on 11/1/07.

8th Floor Stairwell - An access panel was cut and framed on the south wall of the stairwell to serve as a means of evaluating the concealed spaces behind the stairwell. Although minimal mold was found, approximately 150 square feet of gypsum board and shaft liner were removed from the northeast corner (floor level), northwest corner (floor level), and northwest corner (at ceiling level). The area was cleared and released for restoration on 11/2/07.

11th Floor Corridor - An access panel was cut and framed in the ceiling of corridor 11TS1 to serve as a means of evaluating the concealed spaces above the ceiling. A water stained area was observed on the unfinished gypsum board near the elevator door on 11/2/07 and a 2" core was drilled in order to examine the concealed face behind this stain. No water stains or mold were found.

10th Floor Corridor - An access panel was cut and framed in the ceiling of corridor 10TS1 to serve as a means of evaluating the concealed spaces above the ceiling. A faintly water stained area was observed on the unfinished gypsum board near the elevator door on 11/2/07, in the same location as corridor 11TS1. A core was not drilled in this location because the staining appeared to be only on the surface.

5th Floor Corridor - An access panel was cut and framed in the ceiling of corridor 5TS1 to serve as a means of evaluating the concealed spaces above the ceiling. The area was evaluated on 11/2/07 and no water stains or mold were found.

Table 1: Summary of Mean Clearance Concentrations

| Location | Clearance Date | Outside Mean Concentration (Counts/M ³) | Non-Complaint Area Mean Concentration (Counts/M ³) | Containment Mean Concentration (Counts/M ³) |
|----------|----------------|---|--|---|
| 10TS5 | 10/5/07 | 2273 | 427 | 195 |
| 11TS5 | 10/10/07 | 2827 | 31 | 438 |
| SJ1 | 10/11/07 | 5487 | 44 | 33 |
| 3TS5 | 10/24/07 | 7614 | 35 | 1563 |

Table 2: Summary of Confidence Level Critical Values *

| Number of Isolates | P = 0.10 | P = 0.05 |
|--------------------|----------|----------|
| 5 | 0.7000 | 0.8000 |
| 11 | 0.4182 | 0.5273 |
| 13 | 0.3791 | 0.4780 |
| 14 | 0.3626 | 0.4593 |
| 16 | 0.3382 | 0.4265 |
| 17 | 0.3260 | 0.4118 |

* From Table 13.7 of "Bioaerosols: Assessment and Control".

Table 3: Summary of Spearman Rank Order Correlation Values and Confidence Level Critical Values

| Location | Outside Vs. Containment (Rs) | P = 0.10 Confidence Level | Non-Complaint Area Vs. Containment (Rs) | P = 0.10 Confidence Level |
|----------|------------------------------|---------------------------|---|---------------------------|
| 10TS5 | 0.30 | 0.3260 | 0.23 | 0.4182 |
| 11TS5 | 0.46 | 0.3791 | 0.69 | 0.4182 |
| SJ1 | 0.74 | 0.3382 | 0.98 | 0.7000 |
| 3TS5 | 0.85 | 0.3626 | 0.22 | 0.3791 |

Attachment 1

**Aerotech Laboratories Total Fungal Spore Air
Analysis Reports**

Attachment 2

**Aerotech Laboratories Total Fungal Spore
Bulk and Tape Analysis
Report**

Attachment 3

Spearman Rank Order Correlation Calculations

Spearman Rank Order Correlation

Step 1: Rank both sets from highest to lowest.

Step 2: Subtract two sets of ranks to get the difference d .

Step 3: Square the values of d .

Step 4: Add the squared values of d to get $\text{Sigma } d^2$.

Step 5: Use the formula $R_s = 1 - (6 \text{Sigma } d^2/n^3 - n)$, where n = the number of ranks.

Room 10TS5

| Analyte | Outside Mean Conc. | Rank | Containment Mean Conc. | Rank |
|-----------------|-----------------------|------|---------------------------|------|
| Cladosporium | 1369 | 1 | 8 | 3 |
| Basidiospores | 362 | 2 | 5 | 6 |
| Smuts | 144 | 3 | ND | 12 |
| Alternaria | 126 | 4 | ND | 12 |
| Aspergillus | 104 | 5 | 160 | 1 |
| Ascospores | 99 | 6 | 7 | 4.5 |
| Other Colorless | 24 | 7 | ND | 12 |
| Rusts | 13 | 8 | ND | 12 |
| Pithomyces | 9 | 9 | ND | 12 |
| Curvularia | 5 | 10 | ND | 12 |
| Nigrospora | 4 | 11 | ND | 12 |
| Oidium | 2 | 14 | ND | 12 |
| Other Brown | 2 | 14 | 7 | 4.5 |
| Epicoccum | 2 | 14 | ND | 12 |
| Chaetomium | 2 | 14 | ND | 12 |
| Torula | 2 | 14 | ND | 12 |
| Ulocladium | ND | 17 | 9 | 2 |

Difference
in Ranks

Square
Ranks

| | |
|-----|------------|
| 2 | 4 |
| 4 | 16 |
| 9 | 81 |
| 8 | 64 |
| 4 | 16 |
| 1.5 | 2.25 |
| 5 | 25 |
| 4 | 16 |
| 3 | 9 |
| 2 | 4 |
| 1 | 1 |
| 2 | 4 |
| 9.5 | 90.25 |
| 2 | 4 |
| 2 | 4 |
| 2 | 4 |
| 15 | <u>225</u> |

Total = 569.5

$$R_s = 1 - (6)(569.5) / 4896$$

$$R_s = 1 - 0.70$$

$$R_s = 0.30$$

Room 10TS5

| Analyte | Non-Complaint Area Mean Conc. | Rank | Containment Mean Conc. | Rank |
|---------------|----------------------------------|------|---------------------------|------|
| Cladosporium | 120 | 1 | 8 | 3 |
| Aspergillus | 98 | 2 | 160 | 1 |
| Basidiospores | 67 | 3 | 5 | 6 |
| Smuts | 58 | 4 | ND | 9 |
| Alternaria | 40 | 5 | ND | 9 |
| Ascospores | 22 | 6 | 7 | 4.5 |
| Pithomyces | 9 | 7.5 | ND | 9 |
| Chaetomium | 9 | 7.5 | ND | 9 |
| Stachybotrys | 4 | 9 | ND | 9 |
| Ulocladium | ND | 10.5 | 9 | 2 |
| Other Brown | ND | 10.5 | 7 | 4.5 |

| Difference in Ranks | Square Ranks |
|------------------------|-----------------|
|------------------------|-----------------|

| | | |
|---------|-----------|-----------------------------|
| 2 | 4 | $R_s = 1 - (6)(170) / 1194$ |
| 1 | 1 | |
| 3 | 9 | $R_s = 1 - 0.85$ |
| 5 | 25 | |
| 4 | 16 | $R_s = 0.15$ |
| 1.5 | 2.25 | |
| 1.5 | 2.25 | |
| 1.5 | 2.25 | |
| 0 | 0 | |
| 8.5 | 72.25 | |
| 6 | <u>36</u> | |
| Total = | 170 | |

Room 11TS5

| Analyte | Outside Mean Conc. | Rank | Containment Mean Conc. | Rank |
|-----------------|-----------------------|------|---------------------------|------|
| Basidiospores | 1693 | 1 | 23 | 3 |
| Ascospores | 996 | 2 | 13 | 5 |
| Cladosporium | 868 | 3 | 57 | 2 |
| Aspergillus | 191 | 4 | 284 | 1 |
| Alternaria | 33 | 5 | 5 | 10 |
| Rusts | 16 | 6 | ND | 12.5 |
| Smuts | 11 | 7 | 12 | 6 |
| Nigrospora | 7 | 8.5 | ND | 12.5 |
| Other Colorless | 7 | 8.5 | 7 | 8.5 |
| Other Brown | 2 | 10.5 | 9 | 7 |
| Epicoccum | 2 | 10.5 | 7 | 8.5 |
| Stachybotrys | ND | 12.5 | 19 | 4 |
| Chaetomium | ND | 12.5 | 3 | 11 |

| Difference in Ranks | Square Ranks |
|------------------------|-----------------|
|------------------------|-----------------|

| | | |
|---------|-------------|----------------------------|
| 2 | 4 | $Rs = 1 - (6)(198) / 2184$ |
| 3 | 9 | |
| 1 | 1 | $Rs = 1 - 0.54$ |
| 3 | 9 | |
| 5 | 25 | $Rs = 0.46$ |
| 6.5 | 45.25 | |
| 1 | 1 | |
| 4 | 16 | |
| 0 | 0 | |
| 3.5 | 12.25 | |
| 2 | 4 | |
| 8.5 | 72.25 | |
| 1.5 | <u>2.25</u> | |
| Total = | 198 | |

Room 11TS5

| Analyte | Non-Complaint Area Mean Conc. | Rank | Containment Mean Conc. | Rank |
|-----------------|--|-------------|-----------------------------------|-------------|
| Aspergillus | 18 | 1 | 284 | 1 |
| Basidiospores | 13 | 2 | 23 | 3 |
| Ascospores | ND | 7 | 13 | 5 |
| Cladosporium | ND | 7 | 57 | 2 |
| Alternaria | ND | 7 | 5 | 10 |
| Smuts | ND | 7 | 12 | 6 |
| Other Colorless | ND | 7 | 7 | 8.5 |
| Other Brown | ND | 7 | 9 | 7 |
| Epicoccum | ND | 7 | 7 | 8.5 |
| Stachybotrys | ND | 7 | 19 | 4 |
| Chaetomium | ND | 7 | 3 | 11 |

**Difference
in Ranks**

**Square
Ranks**

| | | |
|---------|-----------|-----------------------------|
| 0 | 0 | $Rs = 1 - (6)(69.5) / 1320$ |
| 1 | 1 | |
| 2 | 4 | $Rs = 1 - 0.31$ |
| 5 | 25 | |
| 3 | 9 | $Rs = 0.69$ |
| 1 | 1 | |
| 1.5 | 2.25 | |
| 0 | 0 | |
| 1.5 | 2.25 | |
| 3 | 9 | |
| 4 | <u>16</u> | |
| Total = | 69.5 | |

Room SJ1

| Analyte | Outside Mean Conc. | Rank | Containment Mean Conc. | Rank |
|---------------|-----------------------|------|---------------------------|------|
| Cladosporium | 3280 | 1 | 20 | 1 |
| Basidiospores | 1155 | 2 | 7 | 2.5 |
| Smuts | 249 | 3 | 7 | 2.5 |
| Aspergillus | 235 | 4 | ND | 9.5 |
| Alternaria | 231 | 5 | ND | 9.5 |
| Cercospora | 111 | 6 | ND | 9.5 |
| Ascospores | 109 | 7 | ND | 9.5 |
| Epícocccum | 49 | 8 | ND | 9.5 |
| Rusts | 31 | 9 | ND | 9.5 |
| Arthrínium | 9 | 10.5 | ND | 9.5 |
| Píthomyces | 9 | 10.5 | ND | 9.5 |
| Nigrospora | 7 | 12 | ND | 9.5 |
| Torula | 5 | 13 | ND | 9.5 |
| Chaetómium | 2 | 15 | ND | 9.5 |
| Oídium | 2 | 15 | ND | 9.5 |
| Bipolaris | 2 | 15 | ND | 9.5 |

**Difference
in Ranks** **Square
Ranks**

| | | |
|---------|--------------|--------------------------------|
| 0 | 0 | $R_s = 1 - (6)(183.25) / 4080$ |
| 0.5 | 0.25 | |
| 0.5 | 0.25 | $R_s = 1 - 0.26$ |
| 5.5 | 30.25 | |
| 4.5 | 20.25 | $R_s = 0.74$ |
| 3.5 | 12.25 | |
| 2.5 | 6.25 | |
| 1.5 | 2.25 | |
| 0.5 | 0.25 | |
| 1 | 1 | |
| 1 | 1 | |
| 2.5 | 6.25 | |
| 3.5 | 12.25 | |
| 5.5 | 30.25 | |
| 5.5 | 30.25 | |
| 5.5 | <u>30.25</u> | |
| Total = | 183.25 | |

Room SJ1

| Analyte | Non-Complaint Area Mean Conc. | Rank | Containment Mean Conc. | Rank |
|---------------|----------------------------------|------|---------------------------|------|
| Cladosporium | 13 | 1 | 20 | 1 |
| Alternaria | 11 | 2.5 | ND | 2.5 |
| Aspergillus | 11 | 2.5 | ND | 2.5 |
| Smuts | 9 | 4 | 7 | 4.5 |
| Basidiospores | ND | 5 | 7 | 4.5 |

| Difference in Ranks | Square Ranks |
|------------------------|-----------------|
|------------------------|-----------------|

| | | |
|---------|-------------|----------------------------|
| 0 | 0 | $R_s = 1 - (6)(0.5) / 120$ |
| 0 | 0 | |
| 0 | 0 | $R_s = 1 - 0.025$ |
| 0.5 | 0.25 | |
| 0.5 | <u>0.25</u> | $R_s = 0.975$ |
| Total = | 0.5 | |

Room 3TS5

| Analyte | Outside Mean Conc. | Rank | Containment Mean Conc. | Rank |
|---------------|-----------------------|------|---------------------------|------|
| Cladosporium | 4146 | 1 | 897 | 1 |
| Basidiospores | 2480 | 2 | 283 | 2 |
| Ascospores | 453 | 3 | 119 | 4 |
| Smuts | 193 | 4 | 59 | 5 |
| Alternaria | 149 | 5 | 18 | 7 |
| Aspergillus | 91 | 6 | 148 | 3 |
| Epicoccum | 42 | 7 | 23 | 6 |
| Other Brown | 18 | 8 | 3 | 10.5 |
| Nigrospora | 16 | 9 | 3 | 10.5 |
| Curvularia | 9 | 10 | ND | 13 |
| Rusts | 5 | 11 | 5 | 9 |
| Botrys | 4 | 12.5 | ND | 13 |
| Pithomyces | 4 | 12.5 | ND | 13 |
| Bipolaris | 2 | 14 | 7 | 8 |

| Difference in Ranks | Square Ranks |
|------------------------|-----------------|
|------------------------|-----------------|

| | | |
|---------|-----------|----------------------------|
| 0 | 0 | $R_s = 1 - (6)(70) / 2730$ |
| 0 | 0 | |
| 1 | 1 | $R_s = 1 - 0.15$ |
| 1 | 1 | |
| 2 | 4 | $R_s = 0.85$ |
| 3 | 9 | |
| 1 | 1 | |
| 1.5 | 2.25 | |
| 1.5 | 2.25 | |
| 3 | 9 | |
| 2 | 4 | |
| 0.5 | 0.25 | |
| 0.5 | 0.25 | |
| 6 | <u>36</u> | |
| Total = | 70 | |

Room 3T55

| Analyte | Non-Complaint Area Mean Conc. | Rank | Containment Mean Conc. | Rank |
|---------------|----------------------------------|------|---------------------------|------|
| Basidiospores | 13 | 1.5 | 283 | 2 |
| Aspergillus | 13 | 1.5 | 148 | 3 |
| Cercospora | 4 | 3.5 | ND | 12.5 |
| Chaetomium | 4 | 3.5 | ND | 12.5 |
| Cladosporium | ND | 9 | 897 | 1 |
| Ascospores | ND | 9 | 119 | 4 |
| Smuts | ND | 9 | 59 | 5 |
| Alternaria | ND | 9 | 18 | 7 |
| Epicoccum | ND | 9 | 23 | 6 |
| Other Brown | ND | 9 | 3 | 10.5 |
| Nigrospora | ND | 9 | 3 | 10.5 |
| Rusts | ND | 9 | 5 | 9 |
| Bipolaris | ND | 9 | 7 | 8 |

Difference
in Ranks

Square
Ranks

| | |
|---------|------|
| 0.5 | 0.25 |
| 1.5 | 2.25 |
| 9 | 81 |
| 9 | 81 |
| 8 | 64 |
| 5 | 25 |
| 4 | 16 |
| 2 | 4 |
| 3 | 9 |
| 0.5 | 0.25 |
| 0.5 | 0.25 |
| 0 | 0 |
| 1 | 1 |
| Total = | 284 |

$$R_s = 1 - (6)(284) / 2184$$

$$R_s = 1 - 0.78$$

$$R_s = 0.22$$

CAB LEVEL

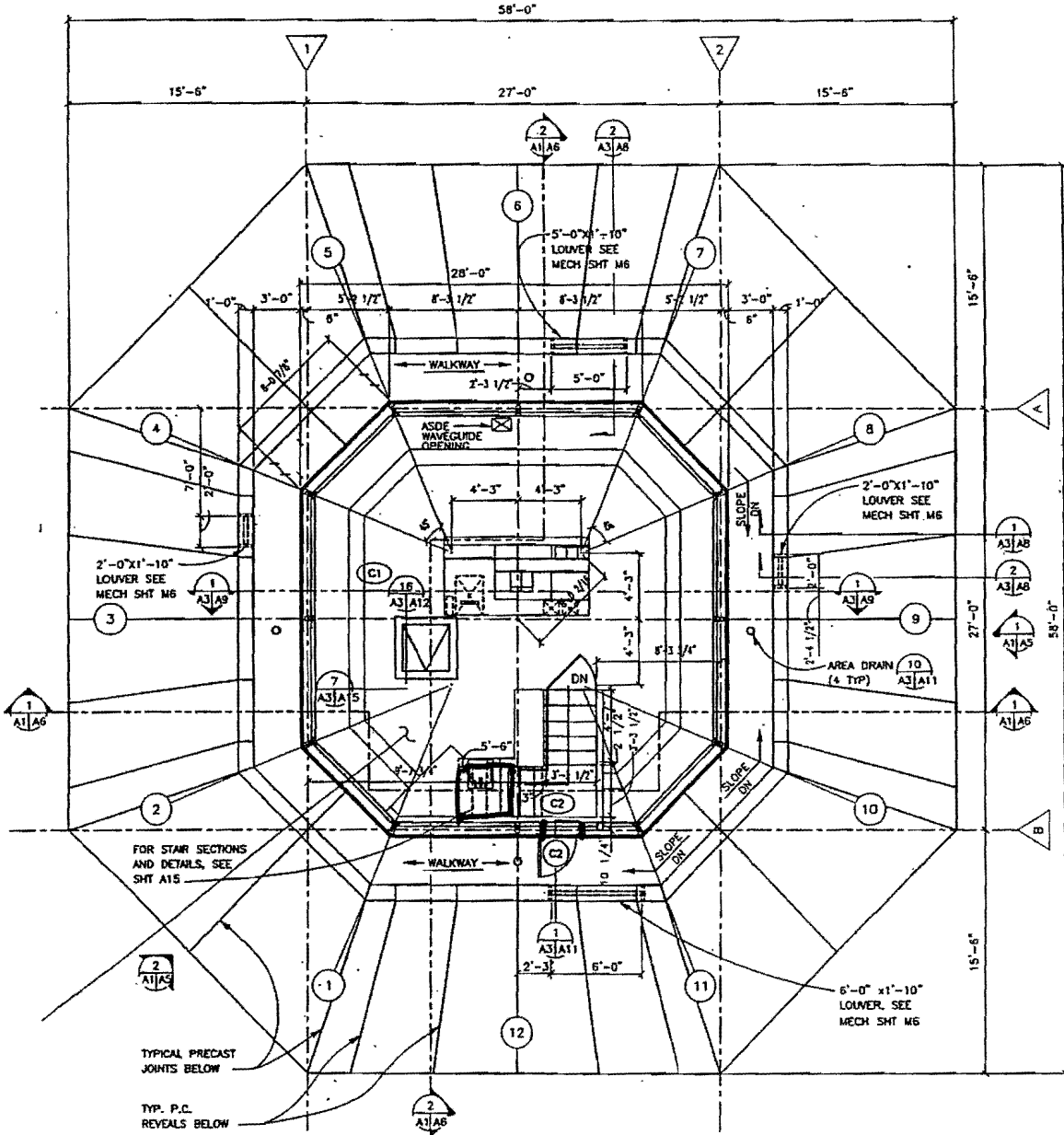

CABLE ACCESS LEVEL

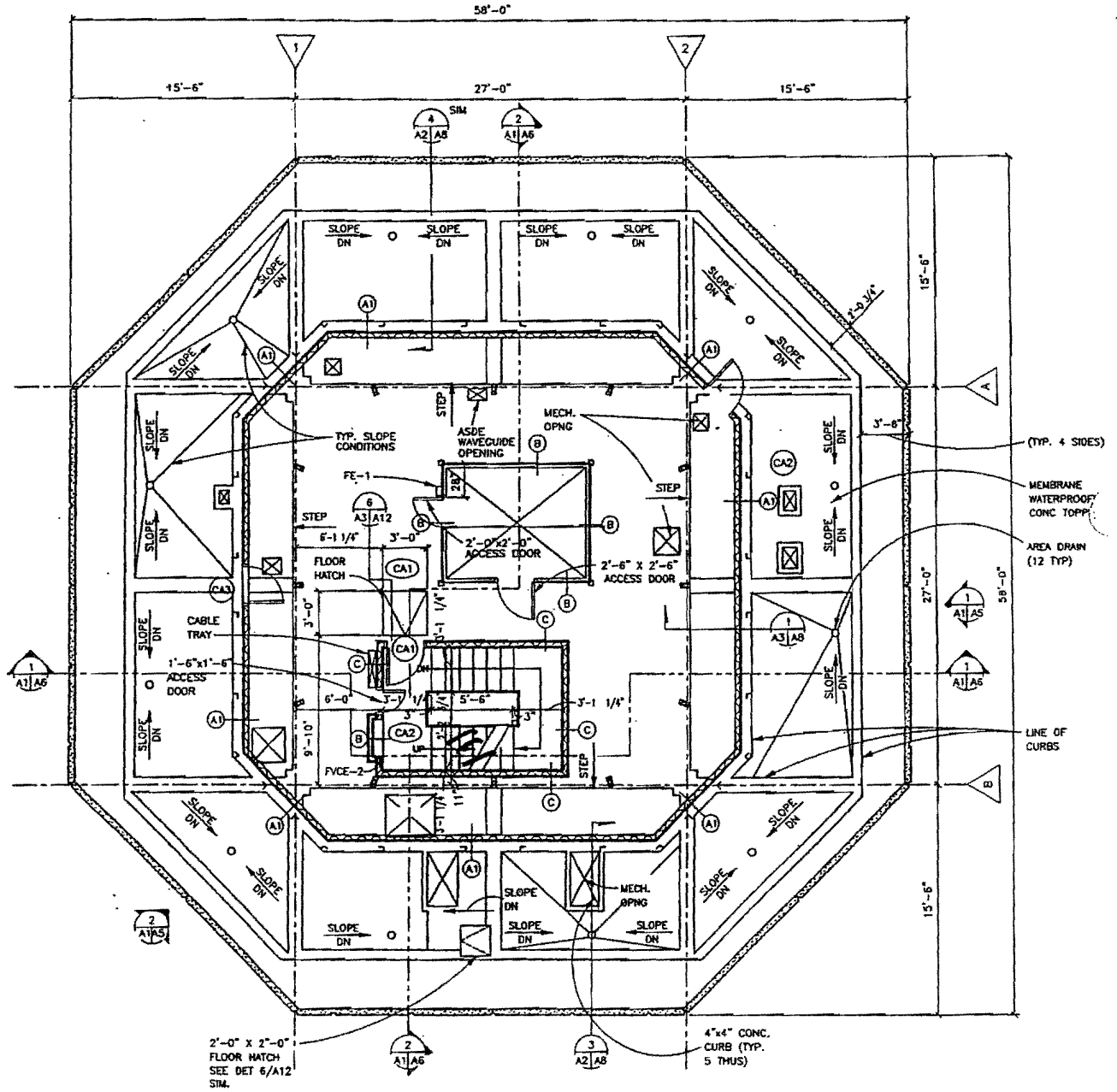

JUNCTION LEVEL

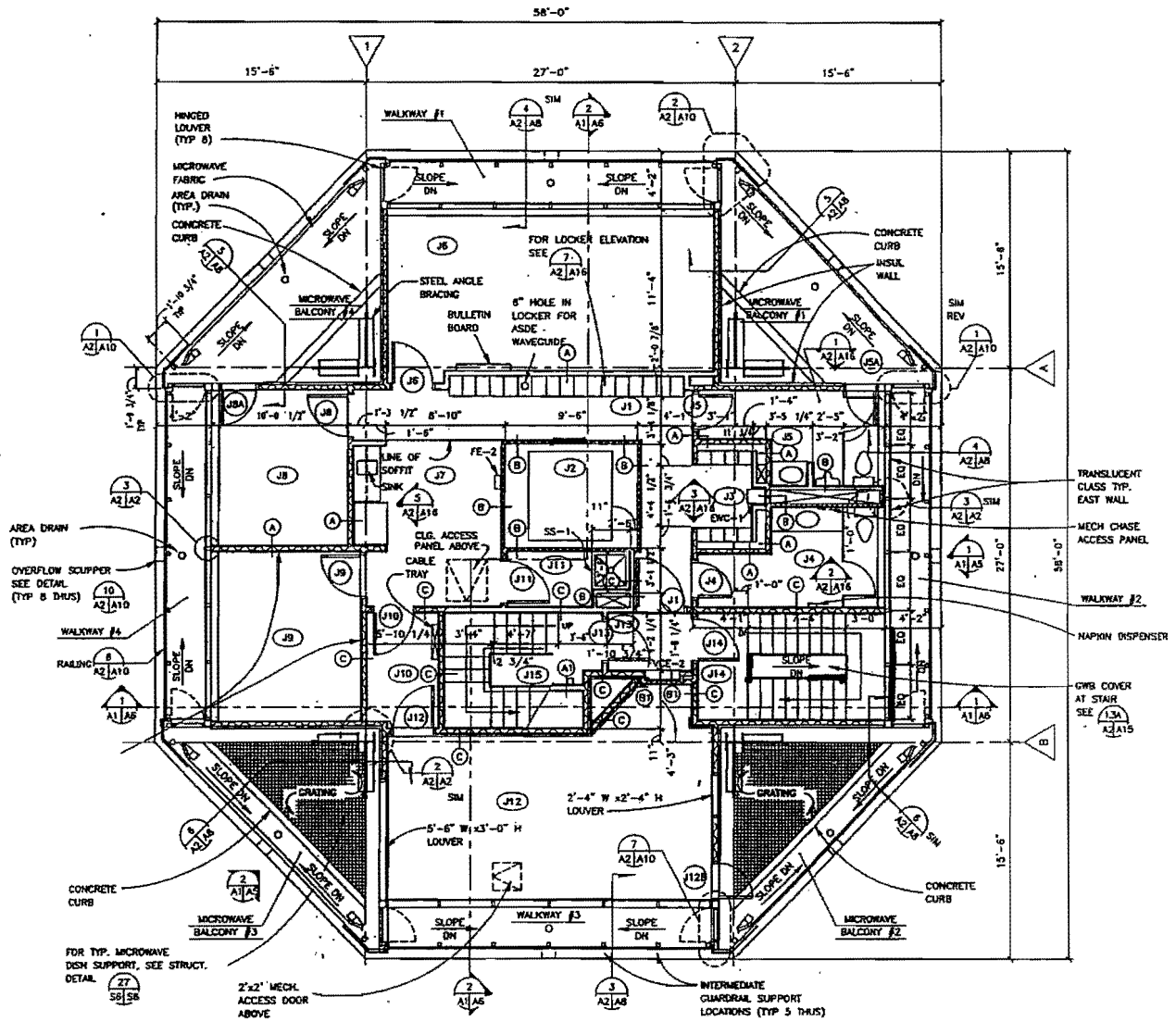

SUBJUNCTION LEVEL

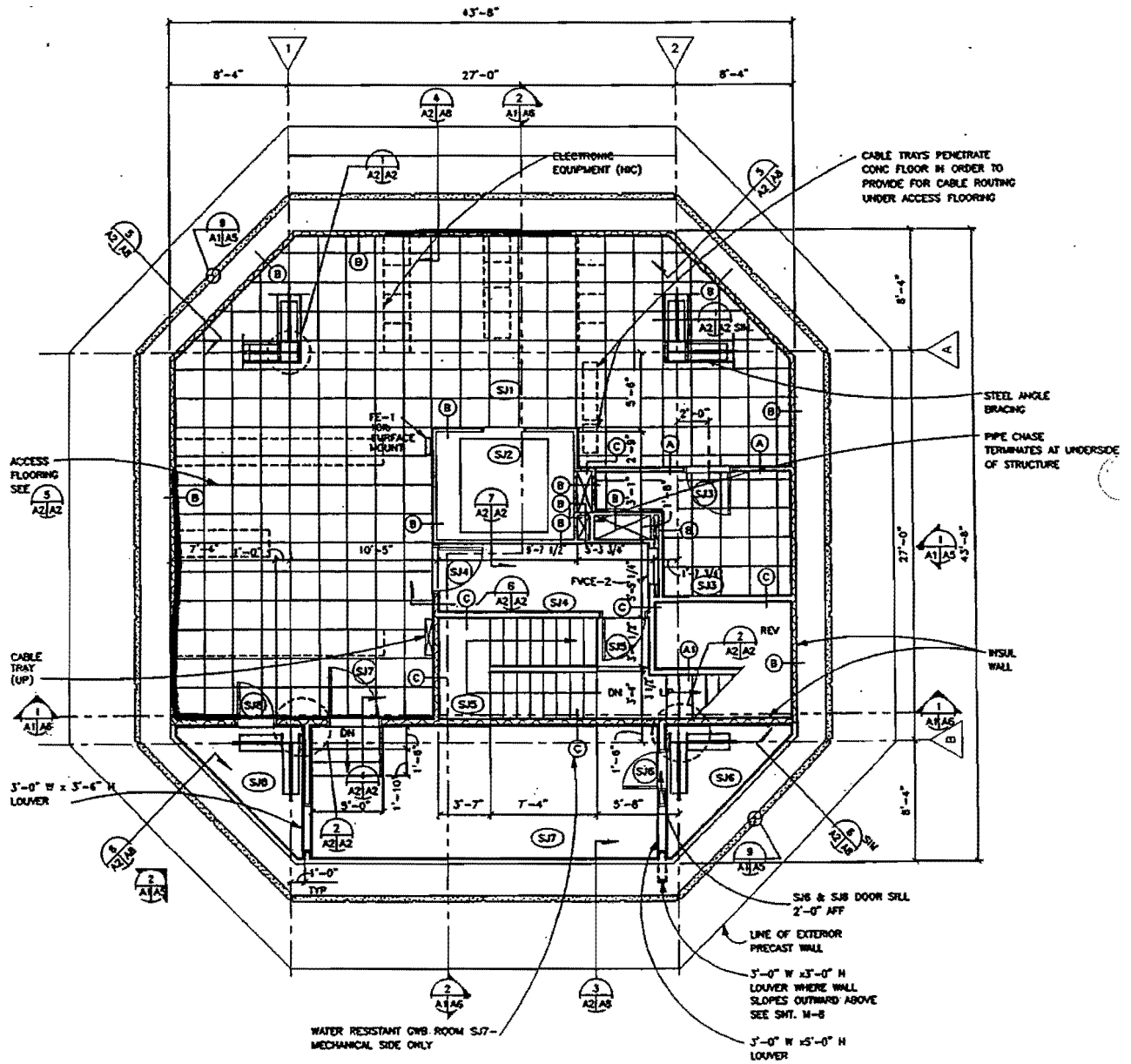

10TH FLOOR

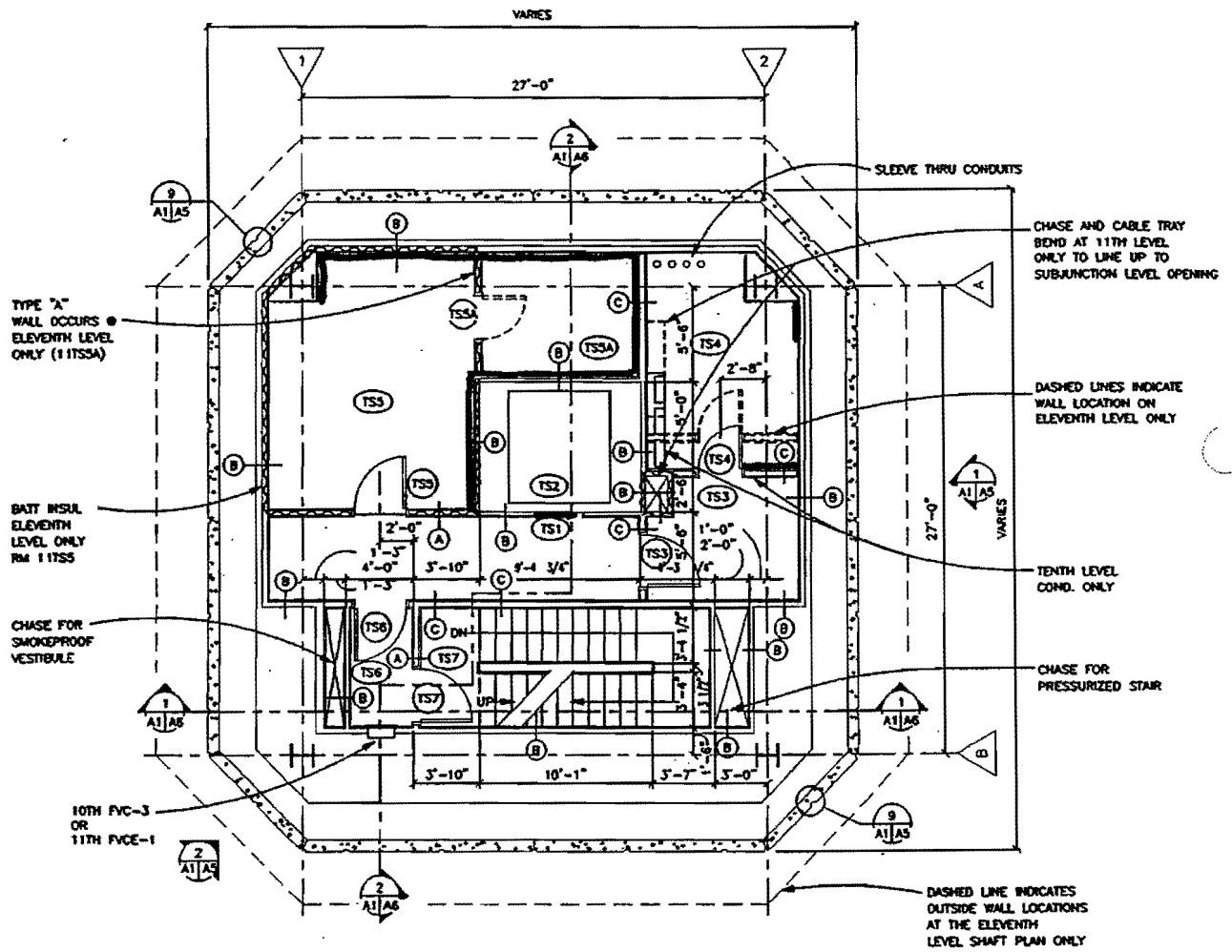

9TH FLOOR

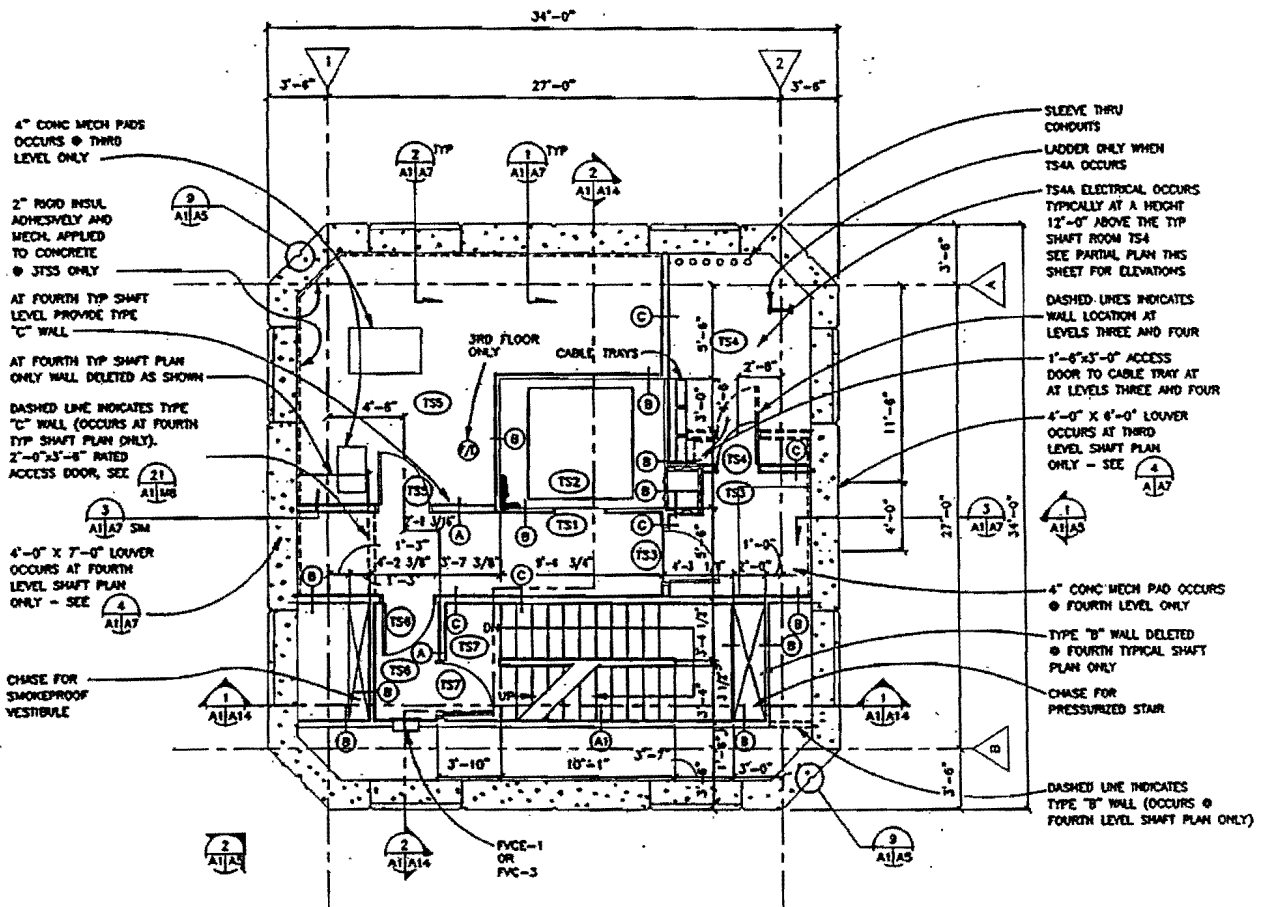

8TH FLOOR

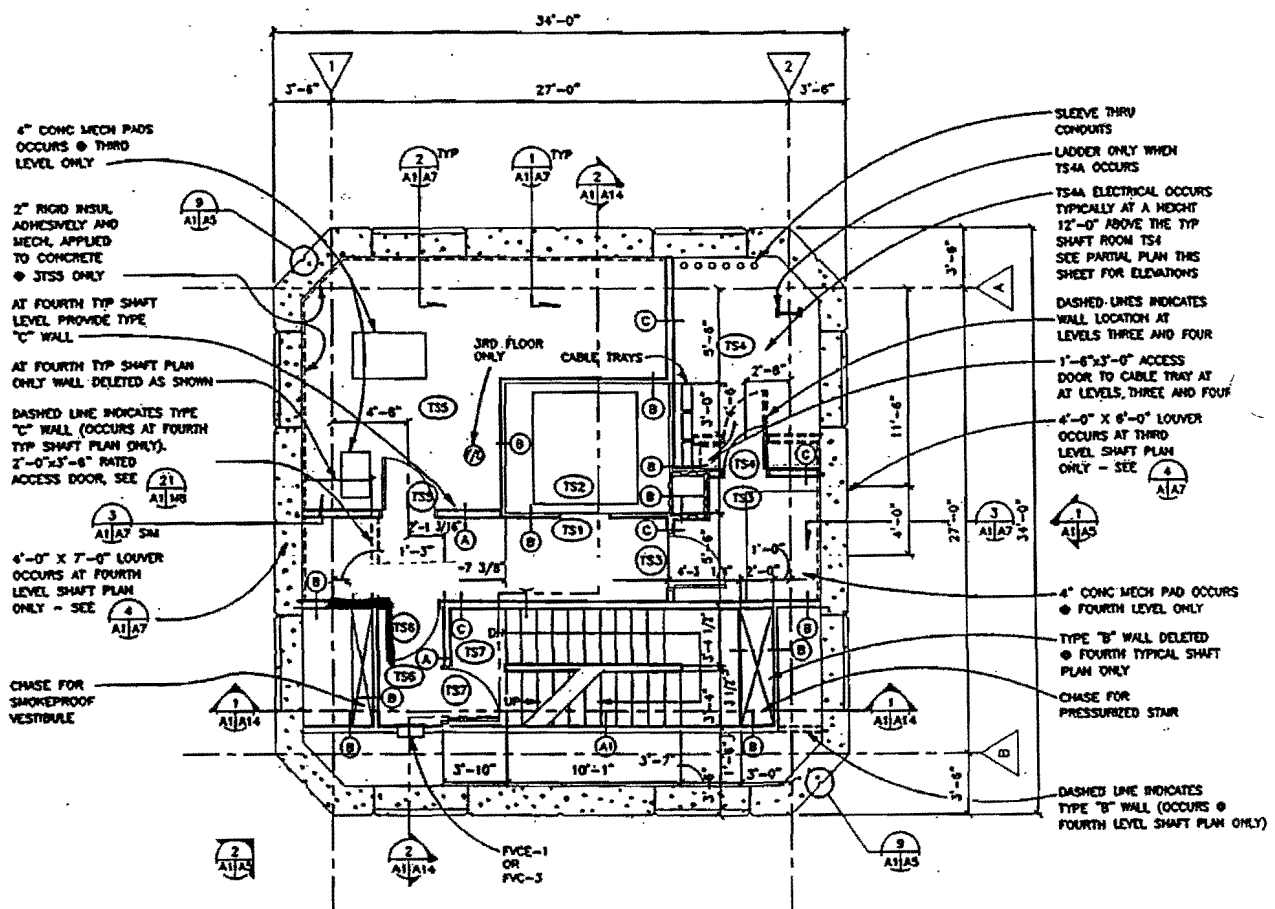

7TH FLOOR

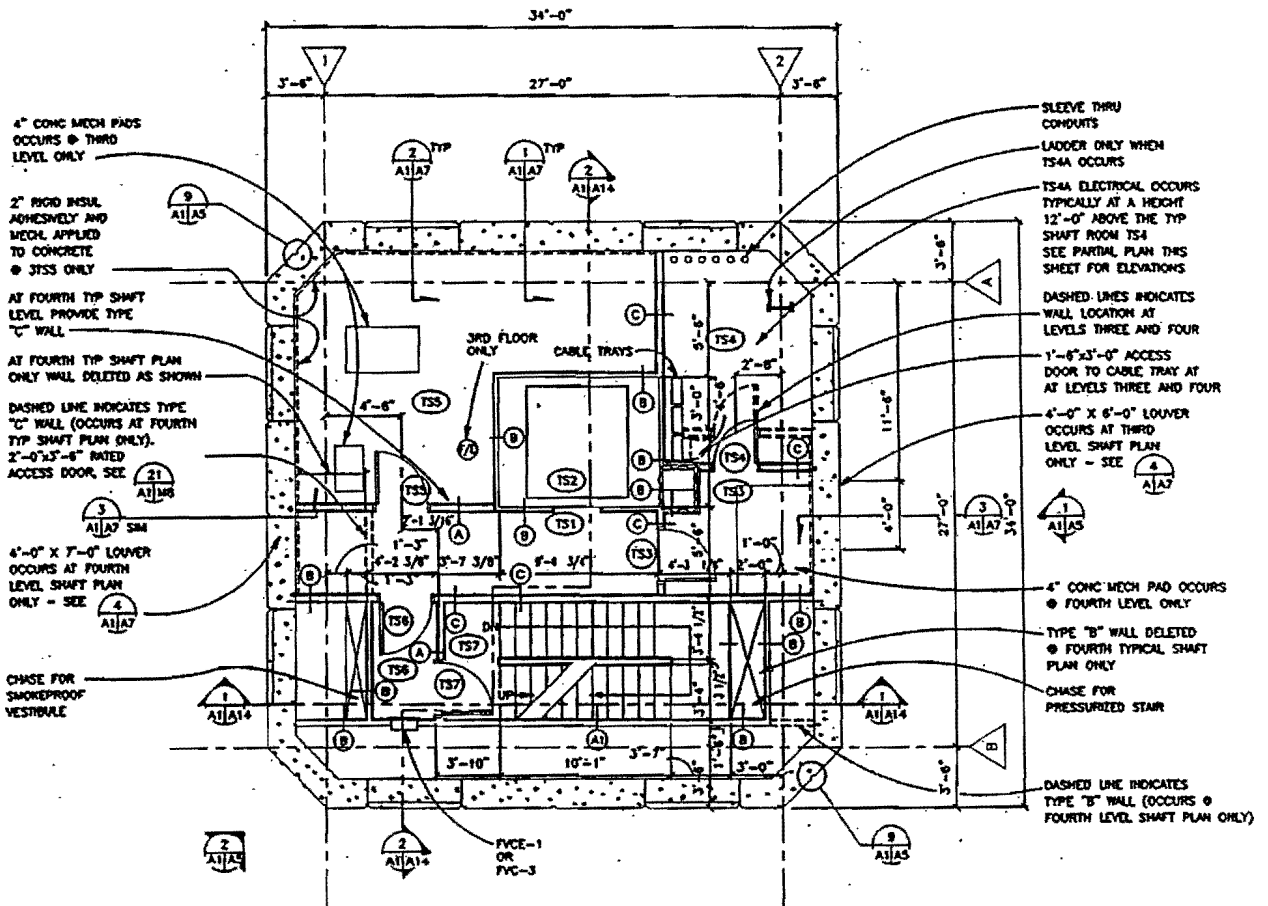

6TH FLOOR

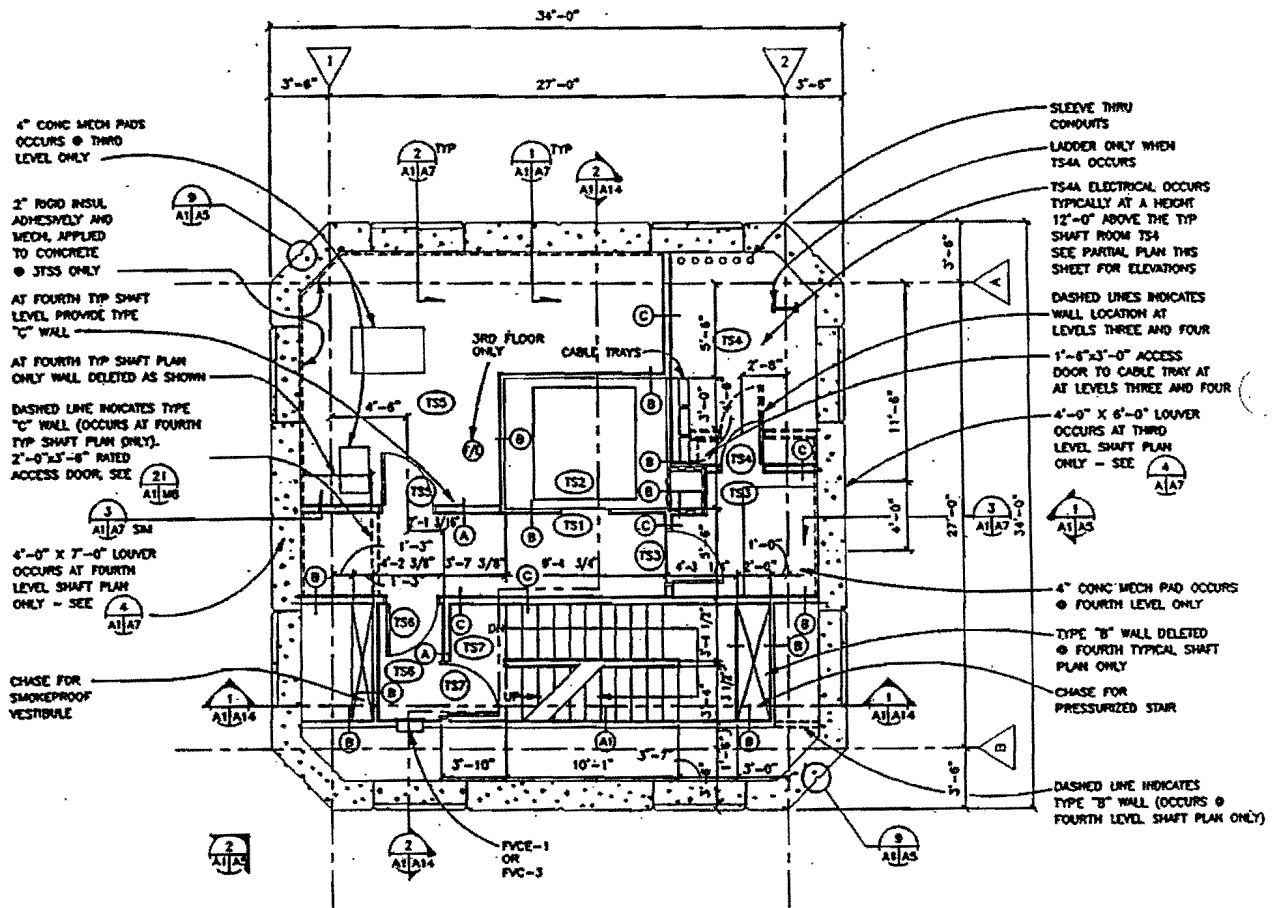

5TH FLOOR

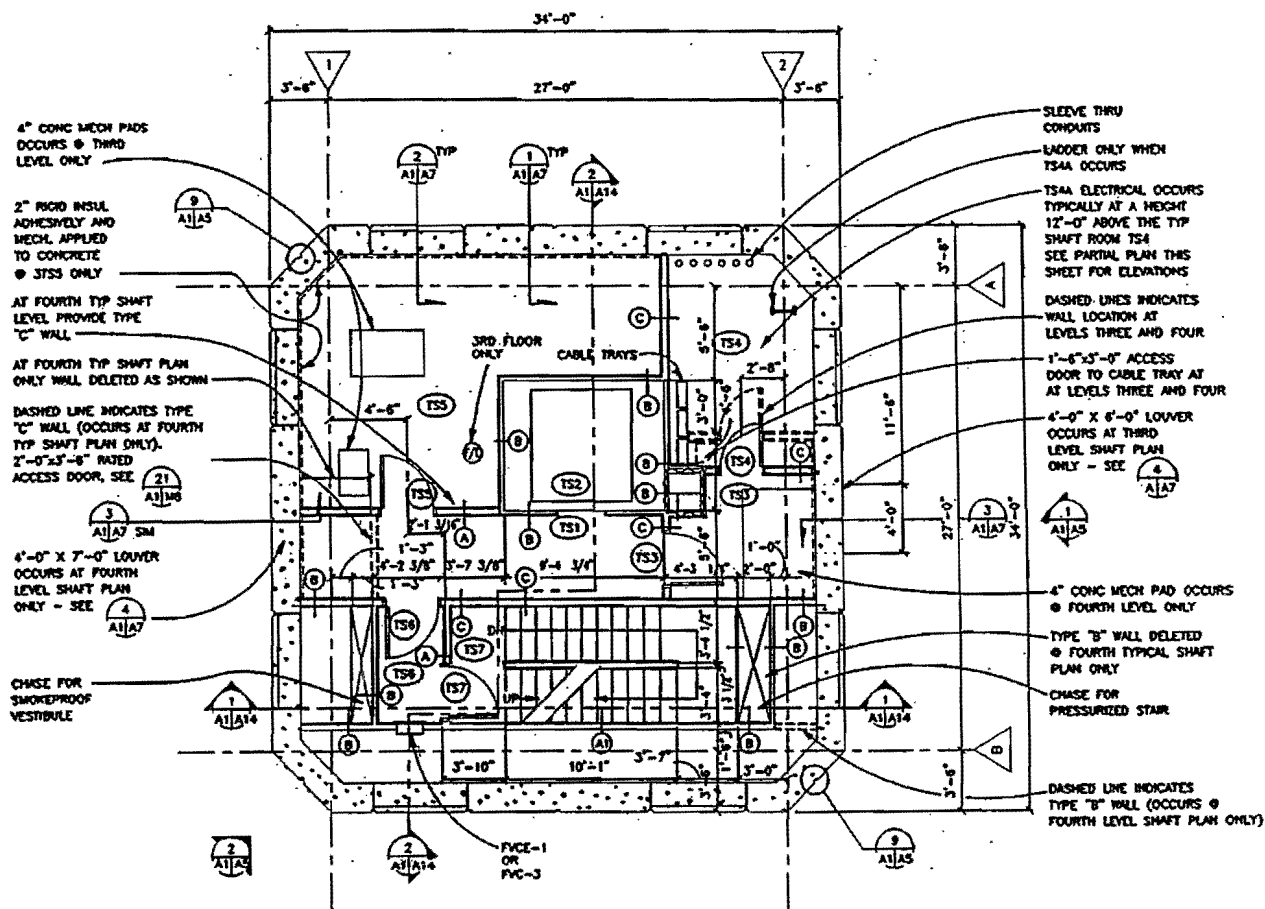

4TH FLOOR

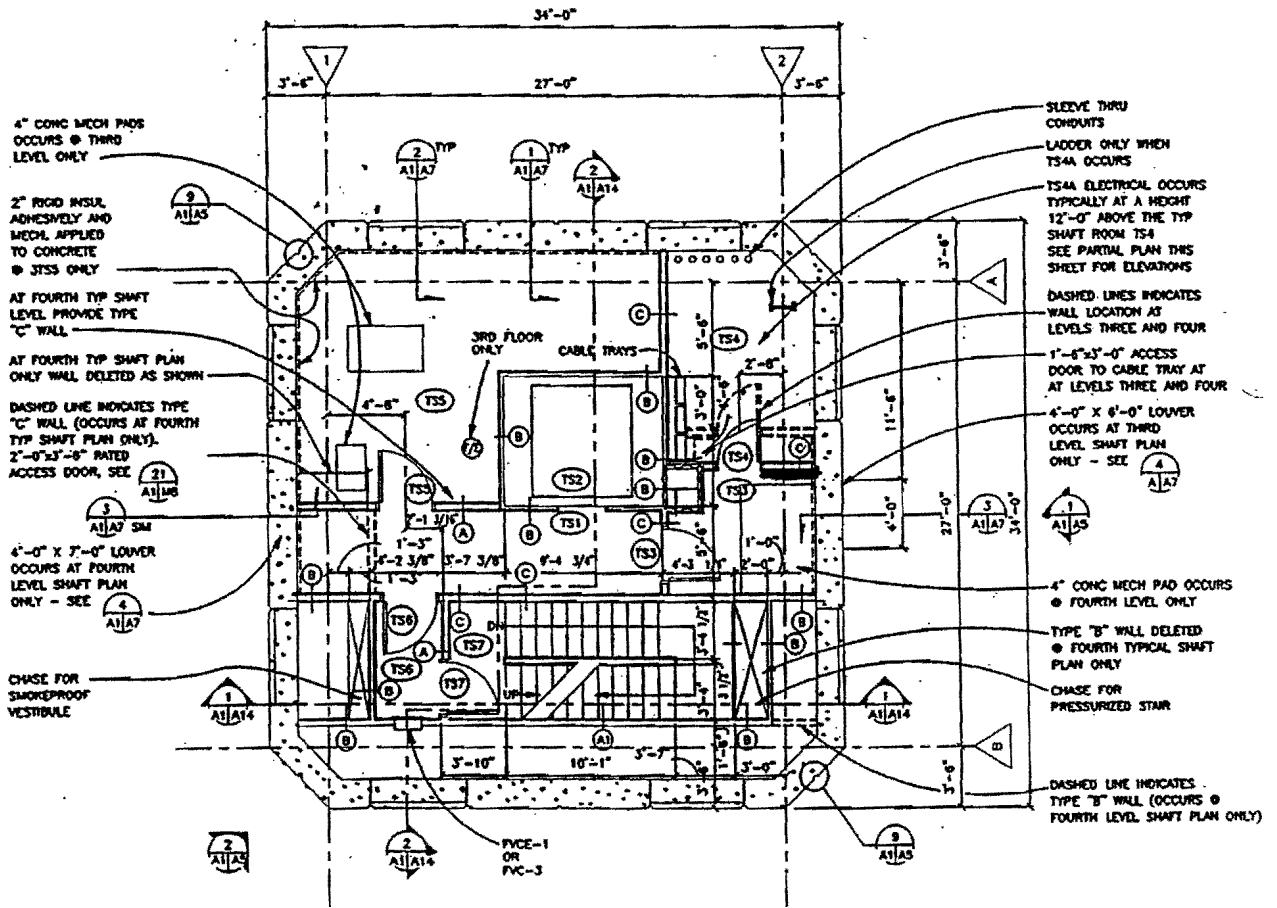

3RD FLOOR

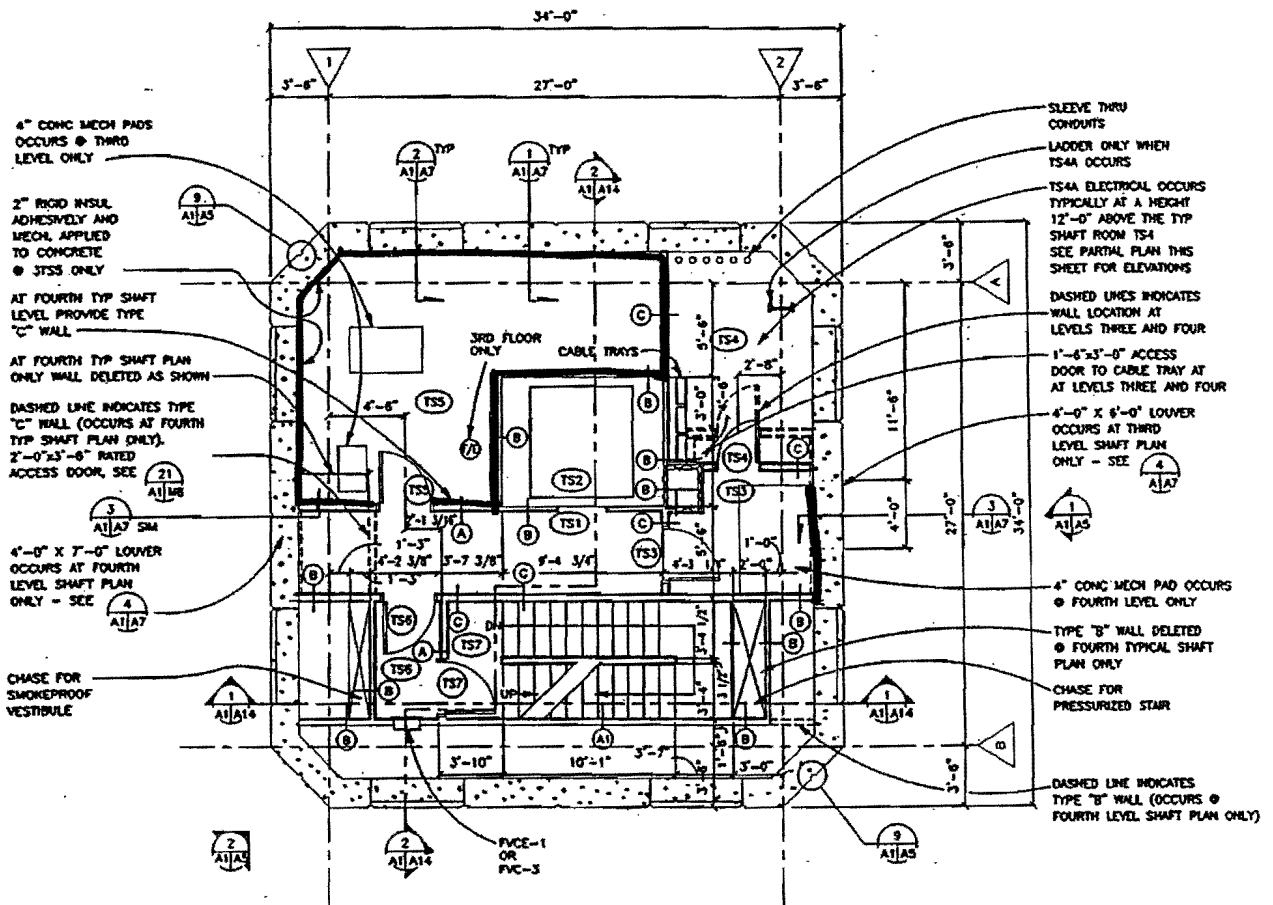

2ND FLOOR

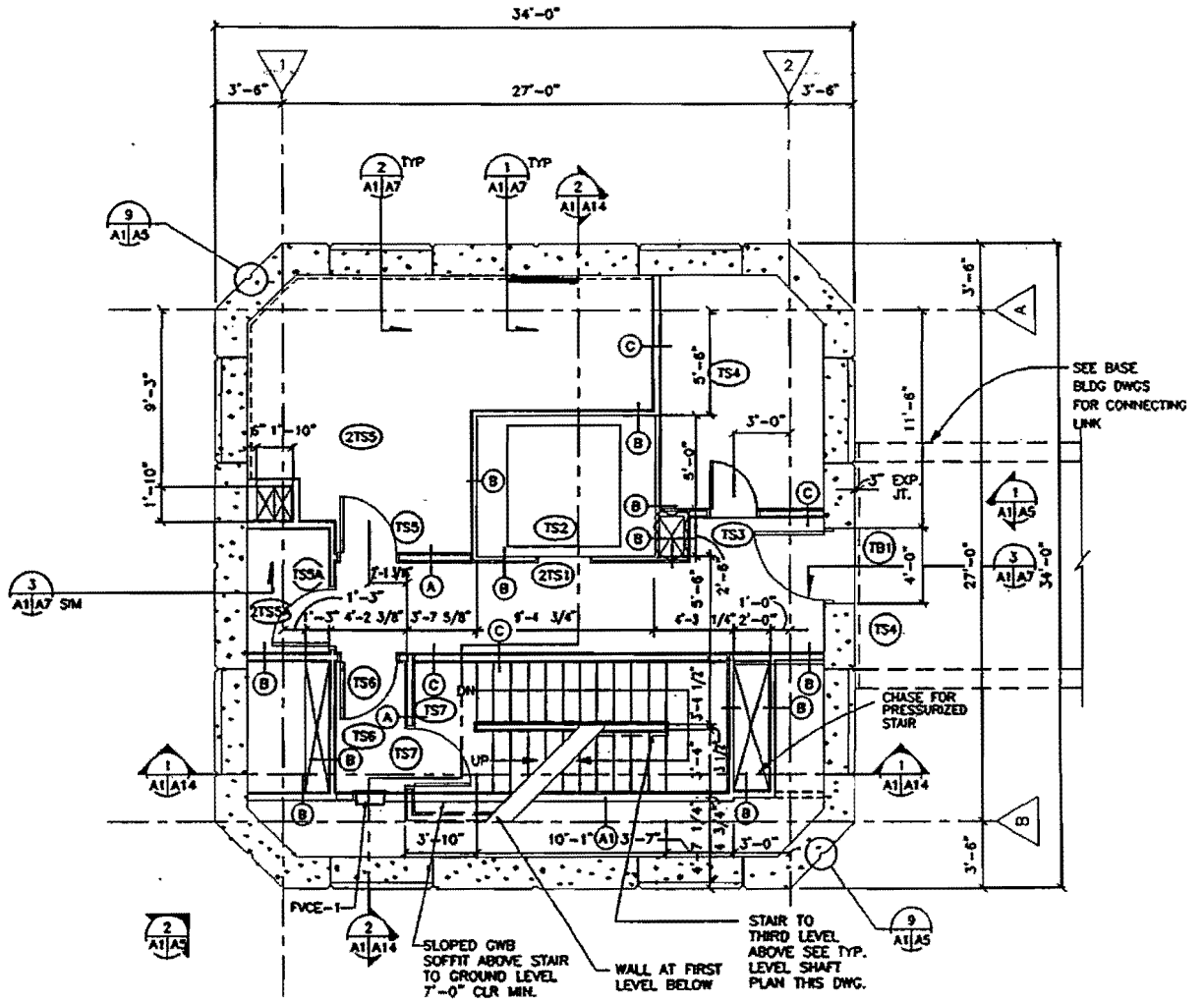

GROUND FLOOR

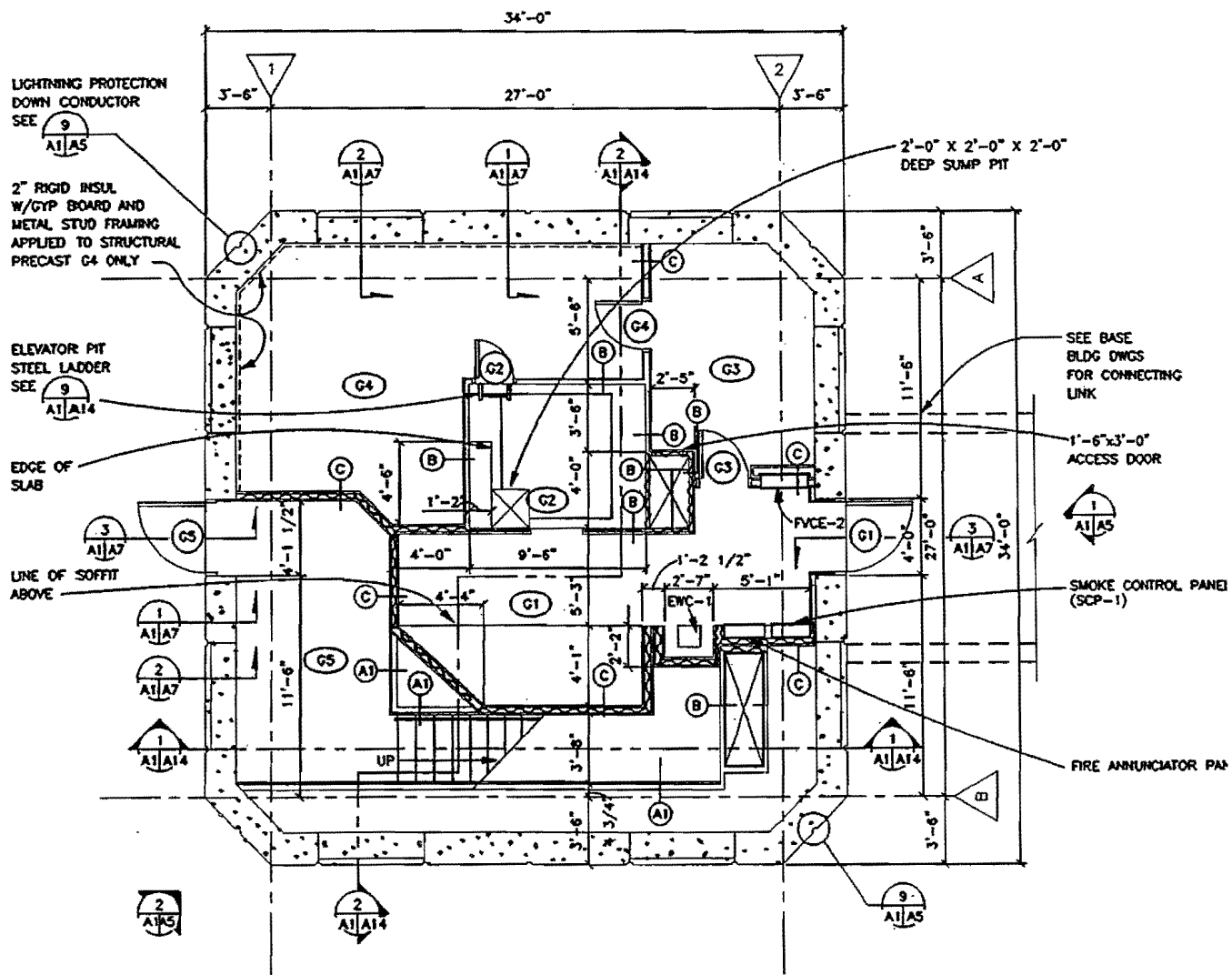

ASDE PENTHOUSE LEVEL

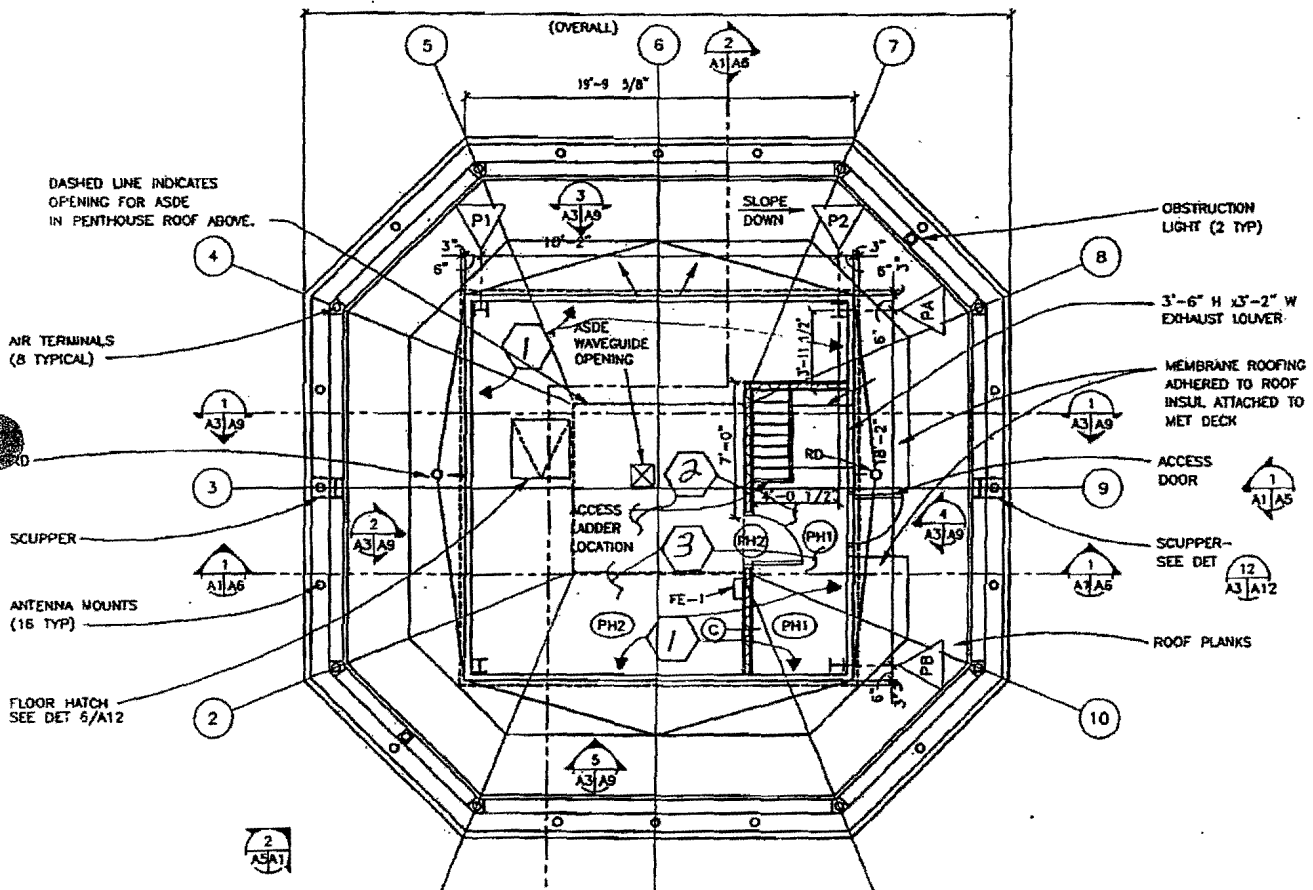

DASHED LINE INDICATES
OPENING FOR ASDE
IN PENTHOUSE ROOF ABOVE.

AIR TERMINALS
(8 TYPICAL)

SCUPPER

ANTENNA MOUNTS
(15 TYP)

FLOOR HATCH
SEE DET 6/A12

(OVERALL)

19'-9 3/8"

SLOPE
DOWN

ASDE
WAVEGUIDE
OPENING

ACCESS
LADDER
LOCATION

OBSTRUCTION
LIGHT (2 TYP)

3'-6" H x 3'-2" W
EXHAUST LOUVER

MEMBRANE ROOFING
ADHERED TO ROOF
INSUL ATTACHED TO
MET DECK

ACCESS
DOOR

SCUPPER-
SEE DET

ROOF PLANKS

CAB LEVEL

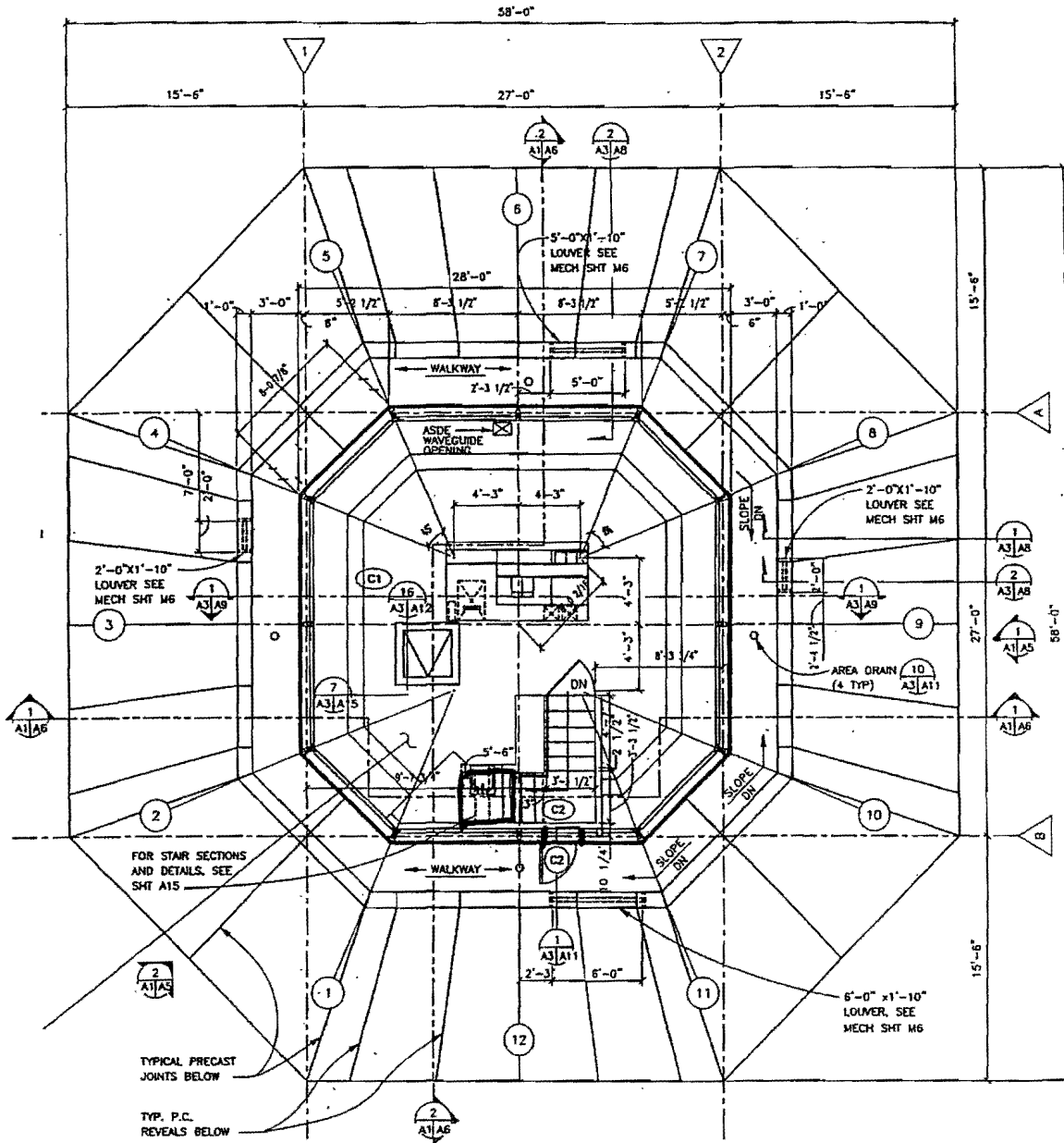

CABLE ACCESS LEVEL

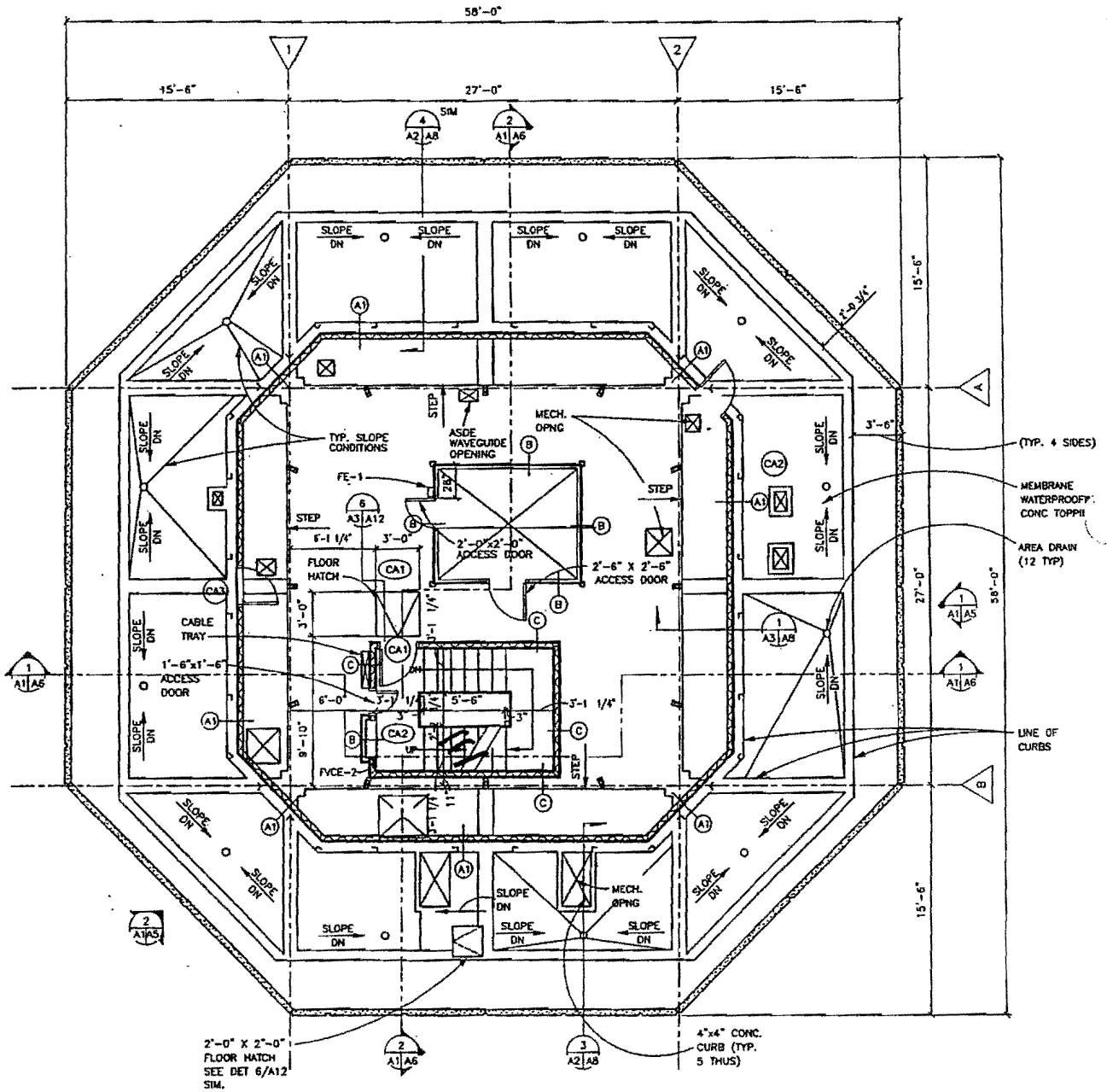

JUNCTION LEVEL

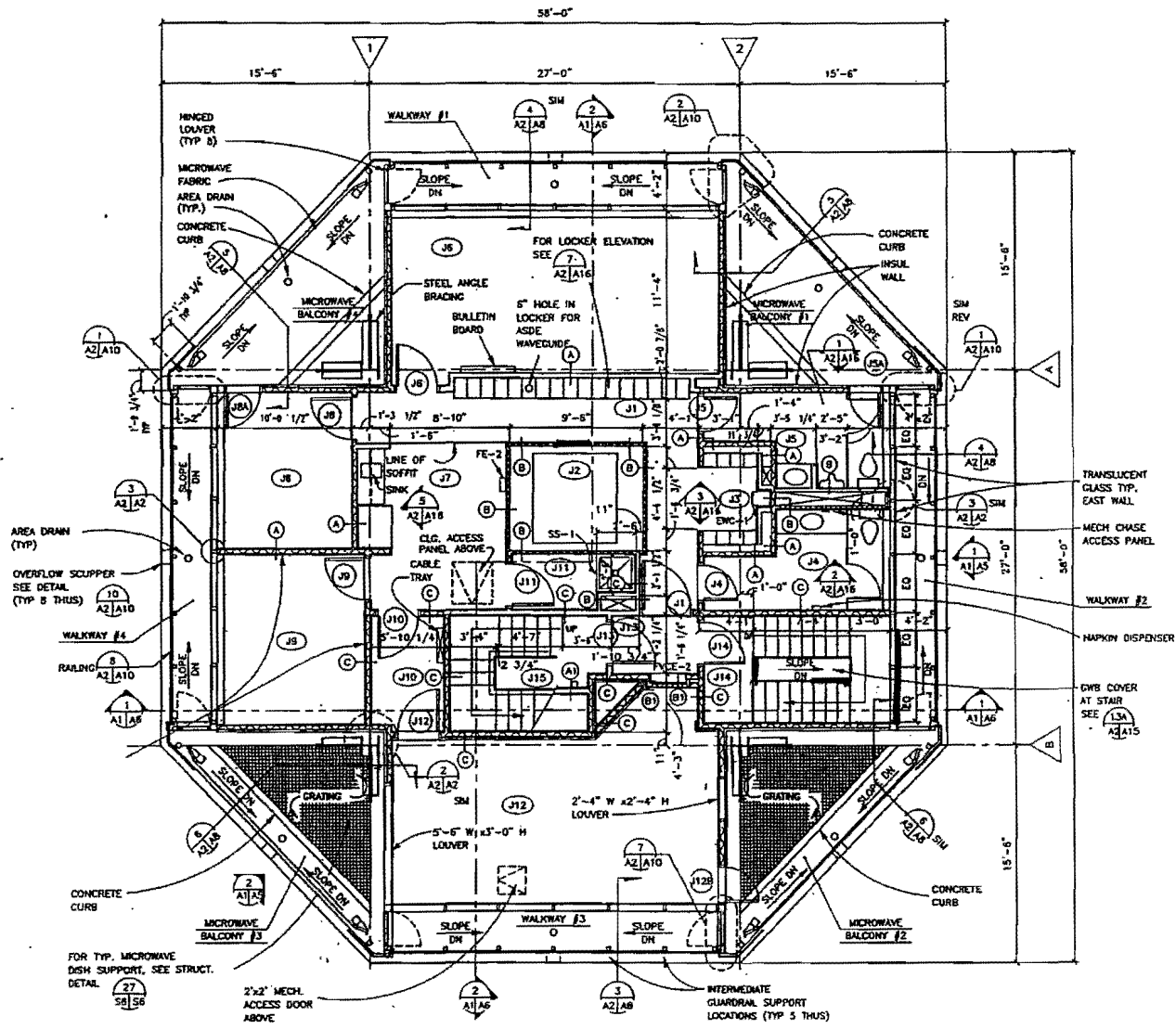

SUBJUNCTION LEVEL

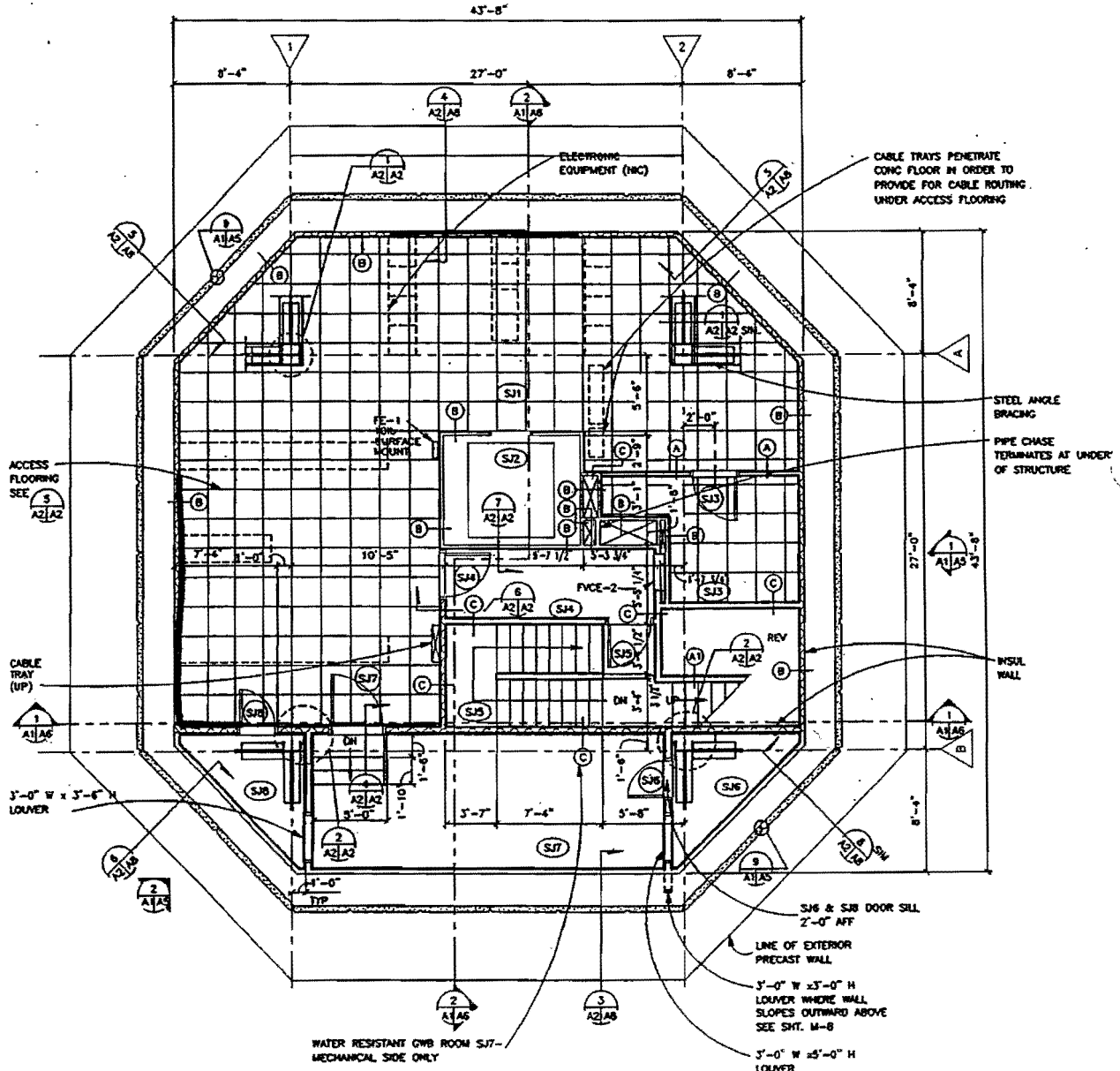

9TH FLOOR

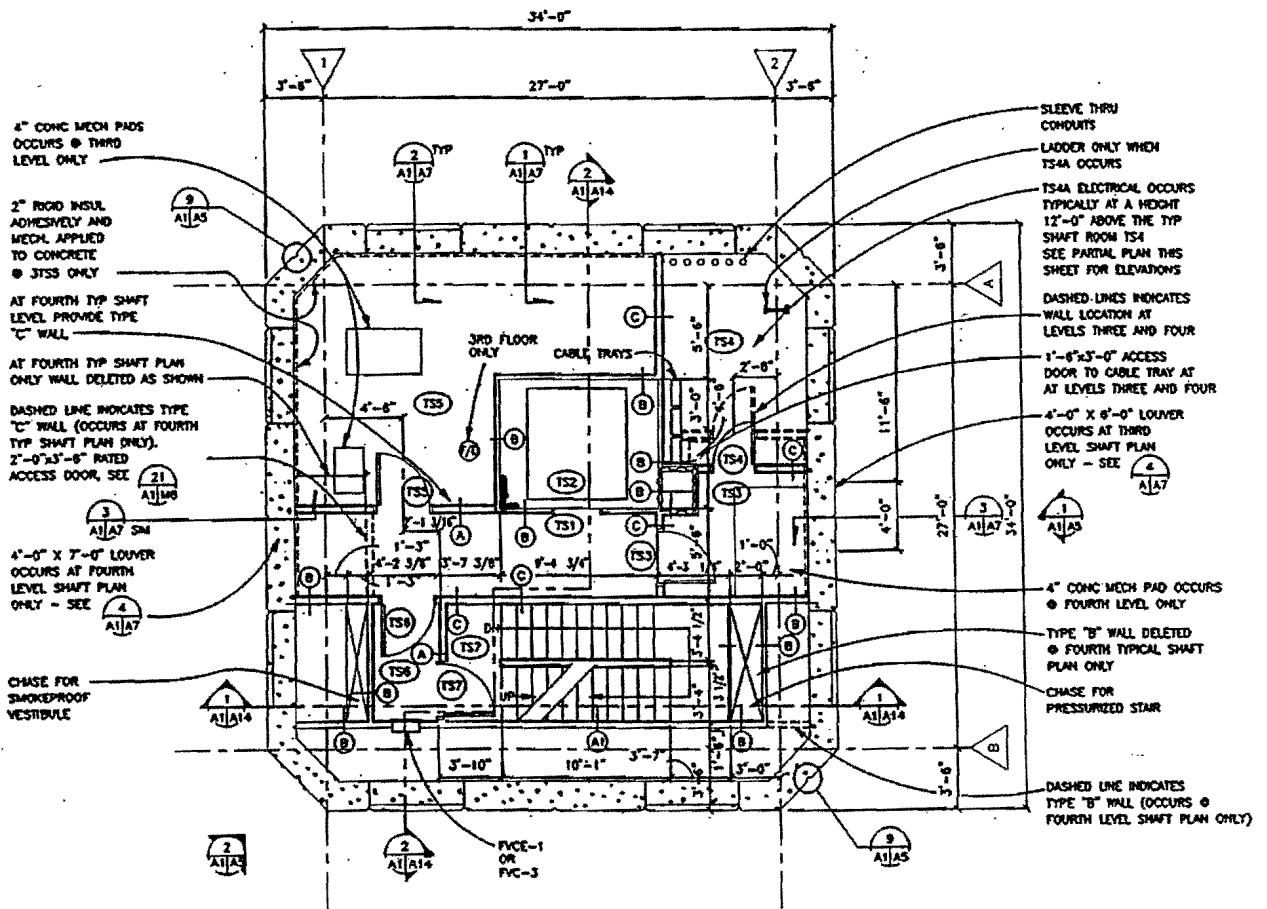

4" CONC MECH PADS OCCURS @ THIRD LEVEL ONLY

2" RIGID INSUL ADHESIVELY AND MECH. APPLIED TO CONCRETE @ JTSS ONLY

AT FOURTH TYP SHAFT LEVEL PROVIDE TYPE "C" WALL

AT FOURTH TYP SHAFT PLAN ONLY WALL DELETED AS SHOWN

DASHED LINE INDICATES TYPE "C" WALL (OCCURS AT FOURTH TYP SHAFT PLAN ONLY). 2'-0" X 3'-6" RATED ACCESS DOOR. SEE 21

4'-0" X 7'-0" LOUVER OCCURS AT FOURTH LEVEL SHAFT PLAN ONLY - SEE 4

CHASE FOR SMOKEPROOF VESTIBULE

SLEEVE THRU CONDUITS

LADDER ONLY WHEN TS4A OCCURS

TS4A ELECTRICAL OCCURS TYPICALLY AT A HEIGHT 12'-0" ABOVE THE TYP SHAFT ROOM TS4 SEE PARTIAL PLAN THIS SHEET FOR ELEVATIONS

DASHED LINES INDICATES WALL LOCATION AT LEVELS THREE AND FOUR

1'-6" X 3'-0" ACCESS DOOR TO CABLE TRAY AT AT LEVELS THREE AND FOUR

4'-0" X 6'-0" LOUVER OCCURS AT THIRD LEVEL SHAFT PLAN ONLY - SEE 4

4" CONC MECH PAD OCCURS @ FOURTH LEVEL ONLY

TYPE "B" WALL DELETED @ FOURTH TYPICAL SHAFT PLAN ONLY

CHASE FOR PRESSURIZED STAIR

DASHED LINE INDICATES TYPE "B" WALL (OCCURS @ FOURTH LEVEL SHAFT PLAN ONLY)

3RD FLOOR ONLY

CABLE TRAYS

FVCE-1 OR FVCE-3

8TH FLOOR

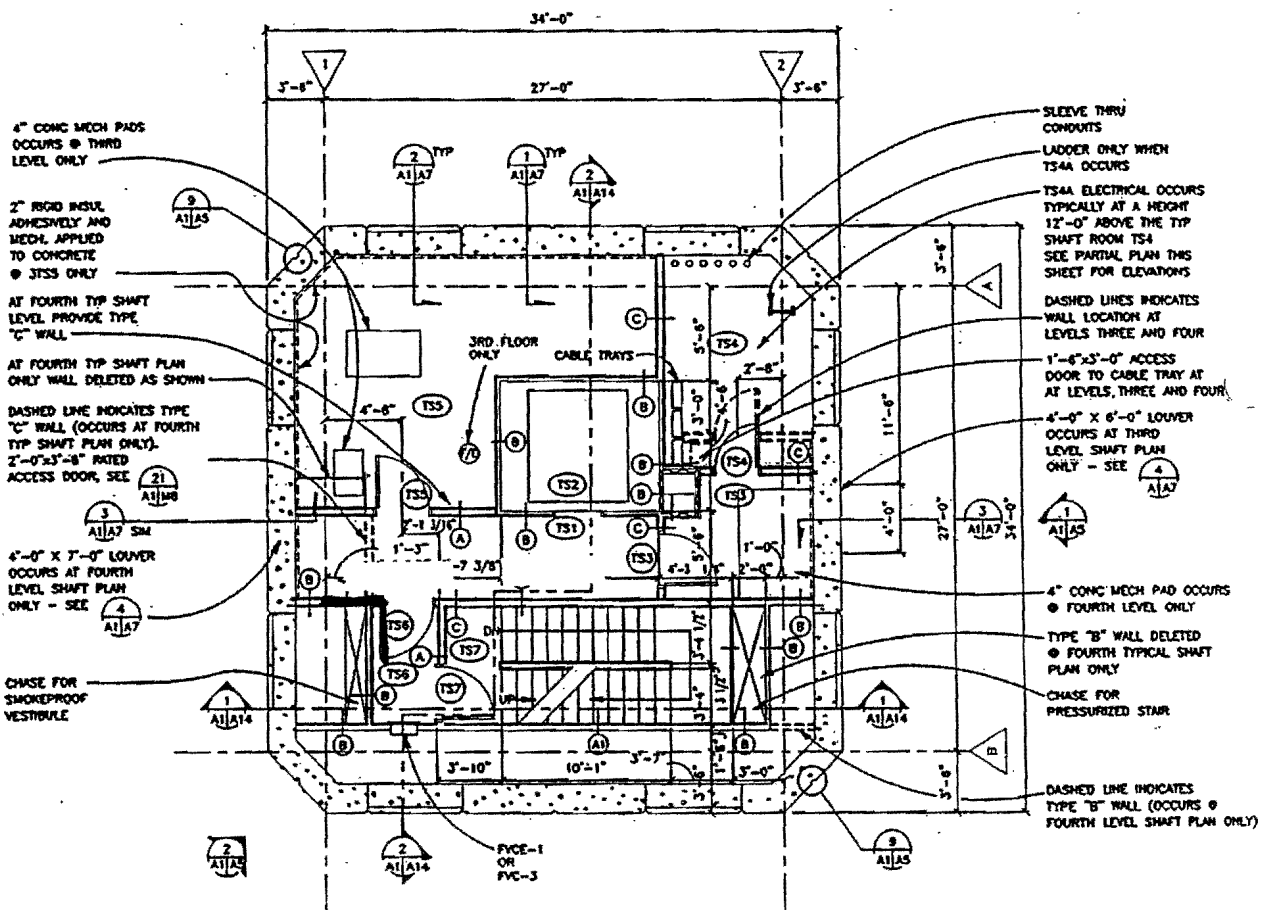

7TH FLOOR

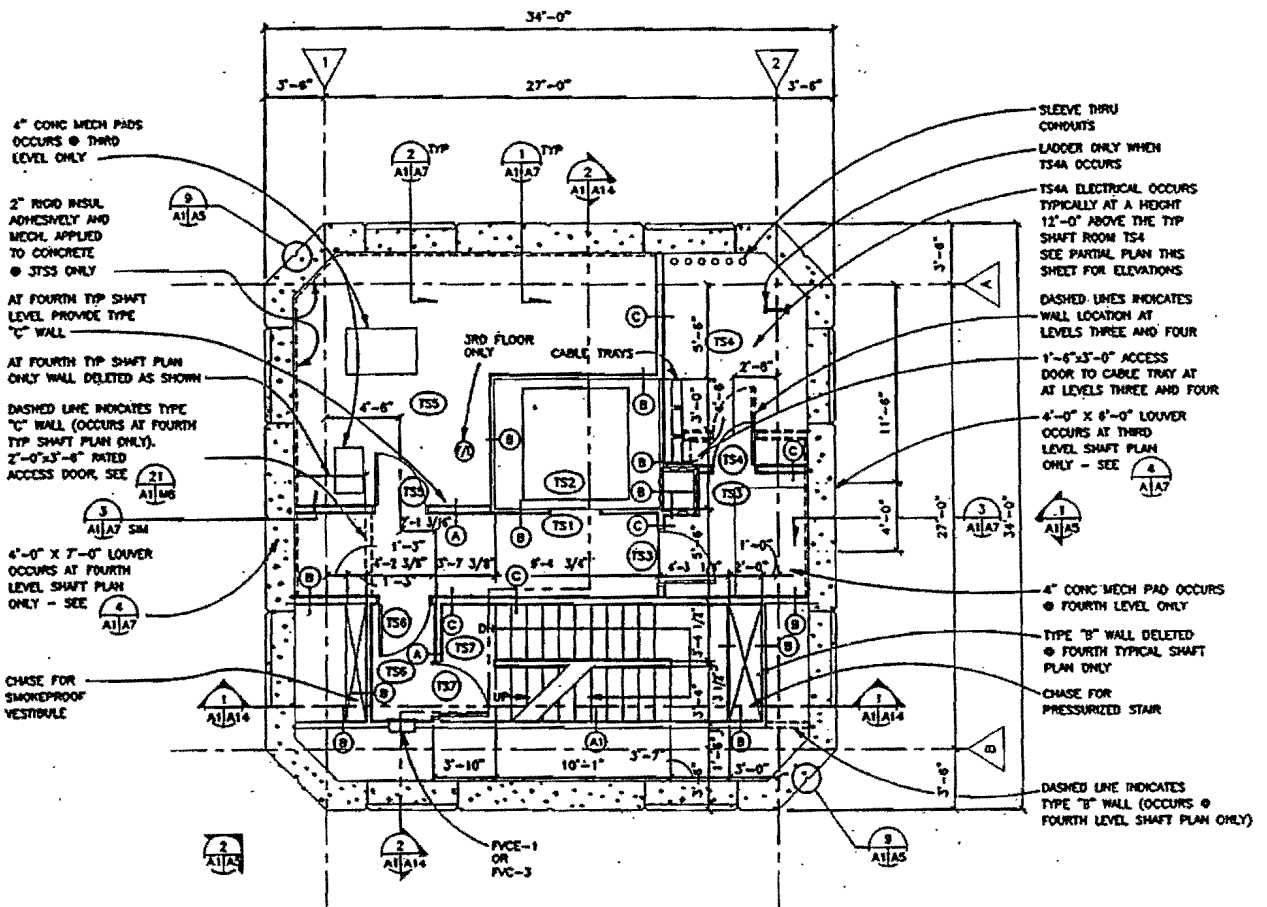

6TH FLOOR

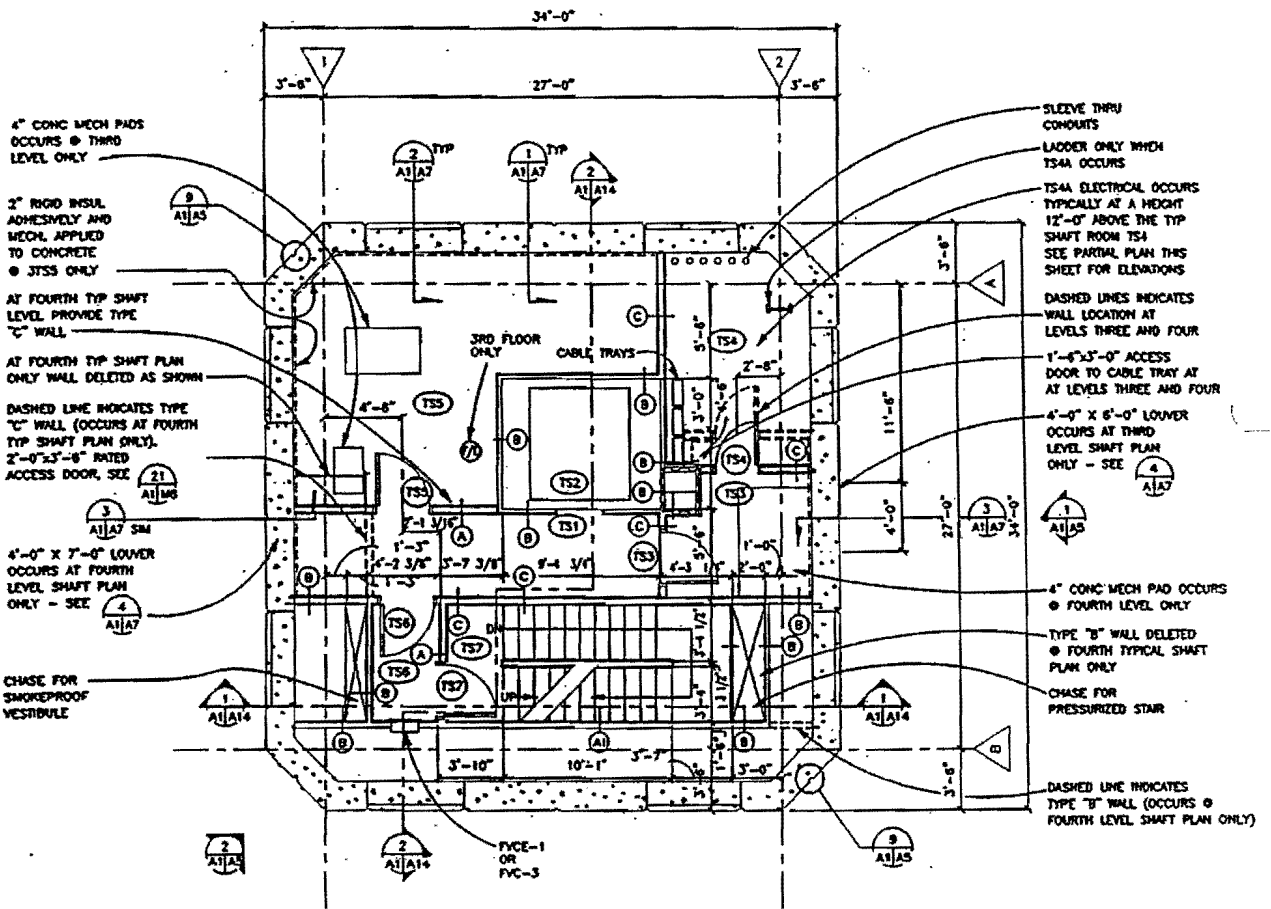

5TH FLOOR

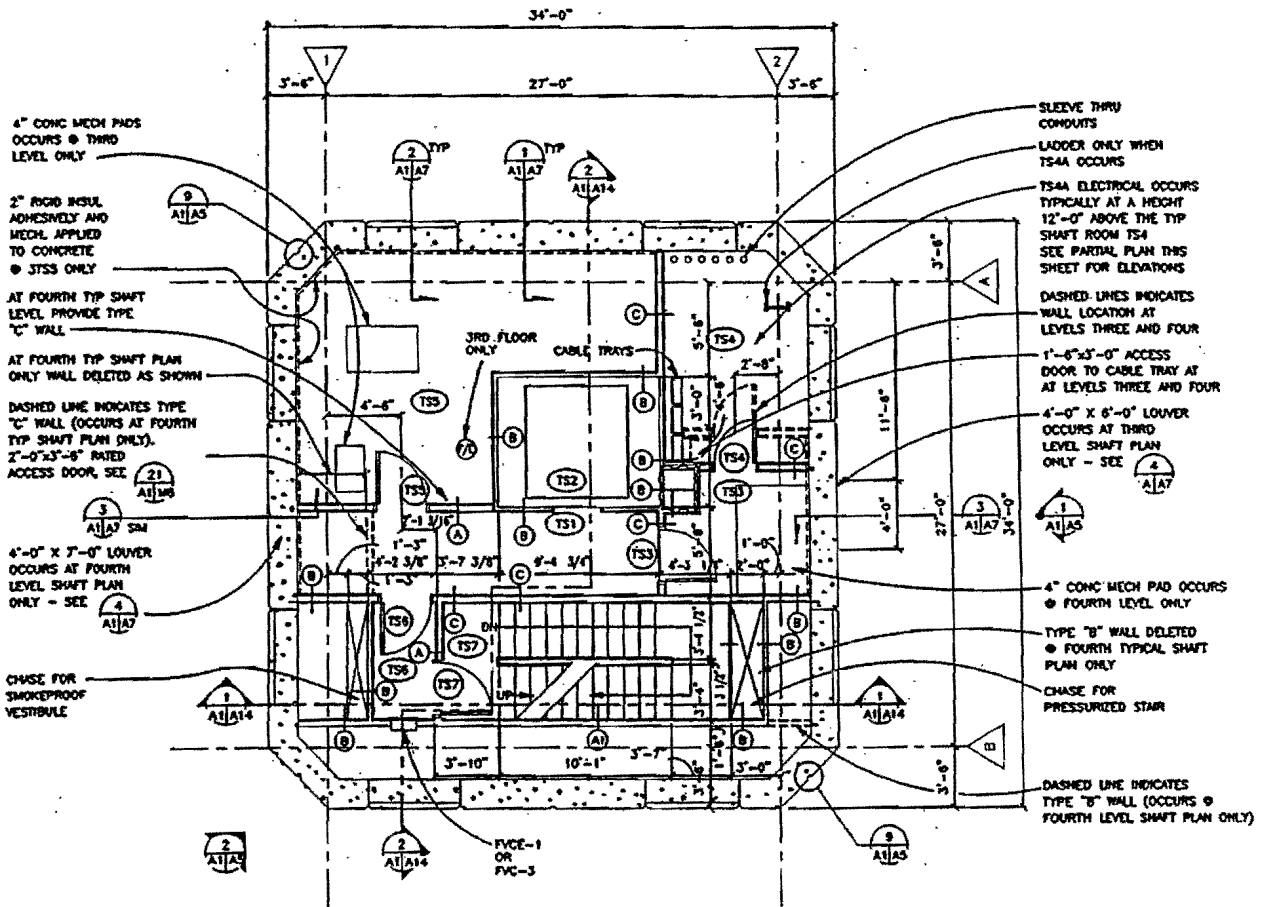

4TH FLOOR

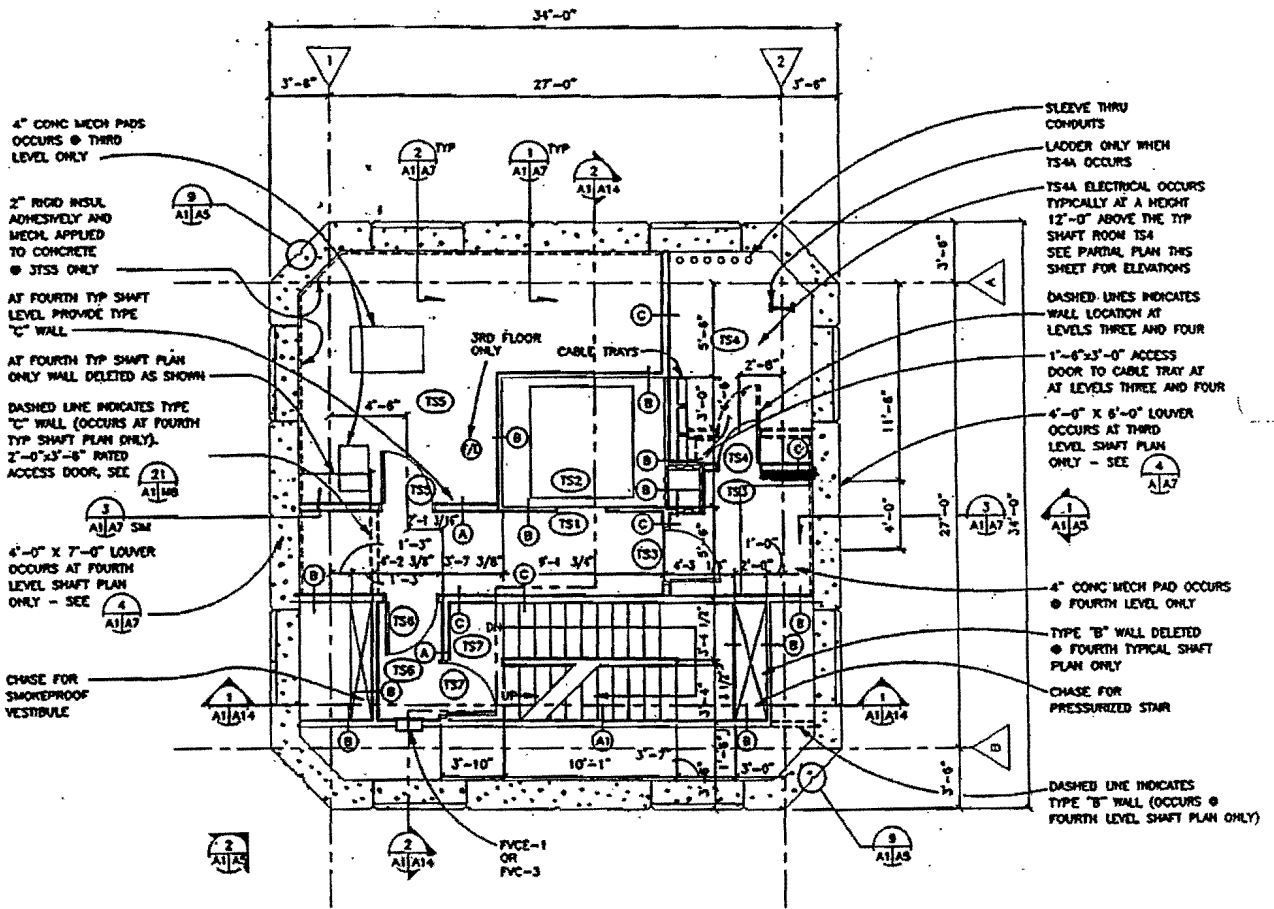

4" CONC MECH PADS OCCURS @ THRD LEVEL ONLY

2" RIGID INSUL ADHESIVELY AND MECH APPLIED TO CONCRETE @ JTSS ONLY

AT FOURTH TYP SHAFT LEVEL PROVIDE TYPE "C" WALL

AT FOURTH TYP SHAFT PLAN ONLY WALL DELETED AS SHOWN

DASHED LINE INDICATES TYPE "C" WALL (OCCURS AT FOURTH TYP SHAFT PLAN ONLY). 2'-0"x3'-8" RATED ACCESS DOOR, SEE 21

3 AJ/A7 SM

4'-0" X 7'-0" LOUVER OCCURS AT FOURTH LEVEL SHAFT PLAN ONLY - SEE 4

CHASE FOR SMOKEPROOF VESTIBULE

SLEEVE THRU CONDUITS LADDER ONLY WHEN TS4A OCCURS

TS4A ELECTRICAL OCCURS TYPICALLY AT A HEIGHT 12'-0" ABOVE THE TYP SHAFT ROOM TS4 SEE PARTIAL PLAN THIS SHEET FOR ELEVATIONS

DASHED LINES INDICATES WALL LOCATION AT LEVELS THREE AND FOUR

1'-6"x3'-0" ACCESS DOOR TO CABLE TRAY AT AT LEVELS THREE AND FOUR

4'-0" X 6'-0" LOUVER OCCURS AT THIRD LEVEL SHAFT PLAN ONLY - SEE 4

4" CONC MECH PAD OCCURS @ FOURTH LEVEL ONLY

TYPE "B" WALL DELETED @ FOURTH TYPICAL SHAFT PLAN ONLY

CHASE FOR PRESSURIZED STAIR

DASHED LINE INDICATES TYPE "B" WALL (OCCURS @ FOURTH LEVEL SHAFT PLAN ONLY)

3RD FLOOR

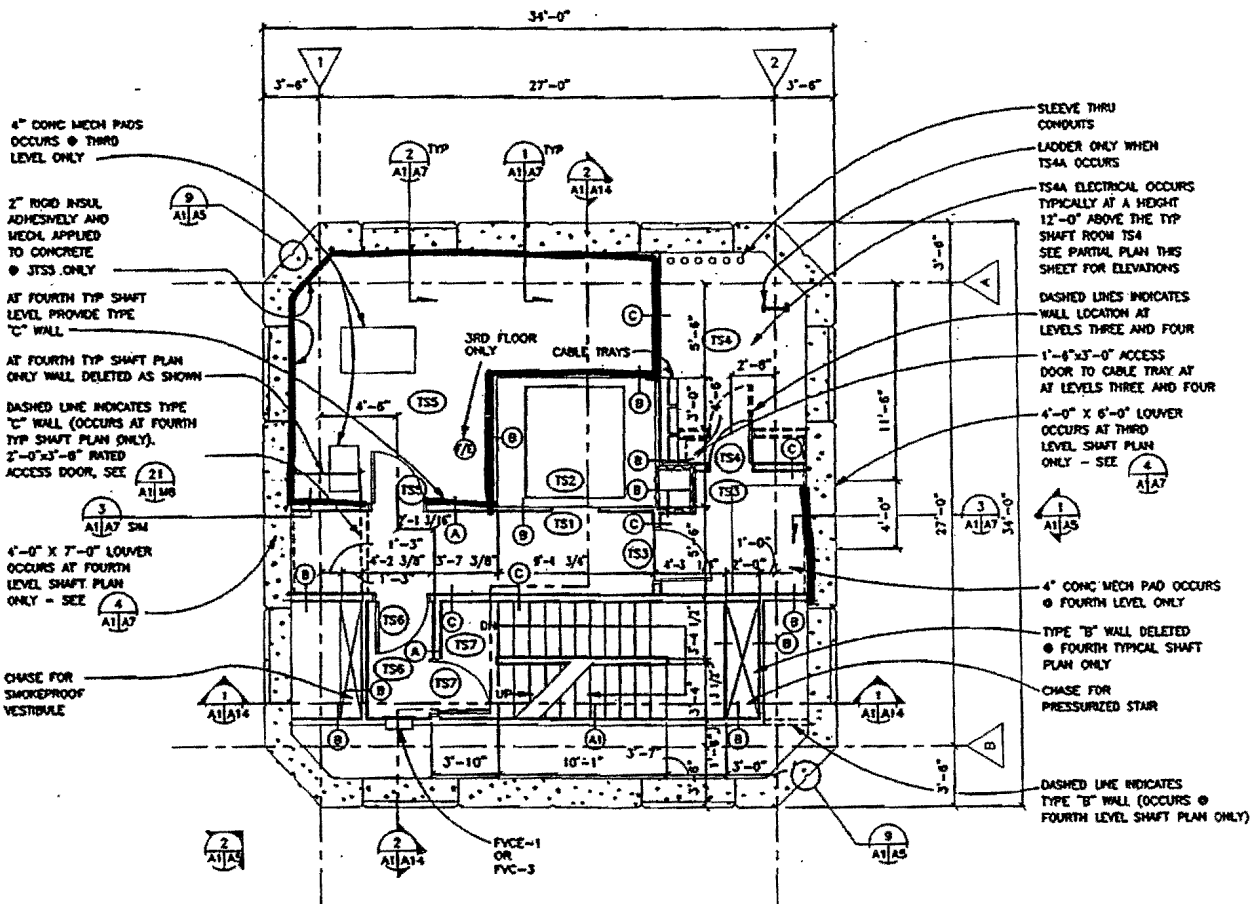

2ND FLOOR

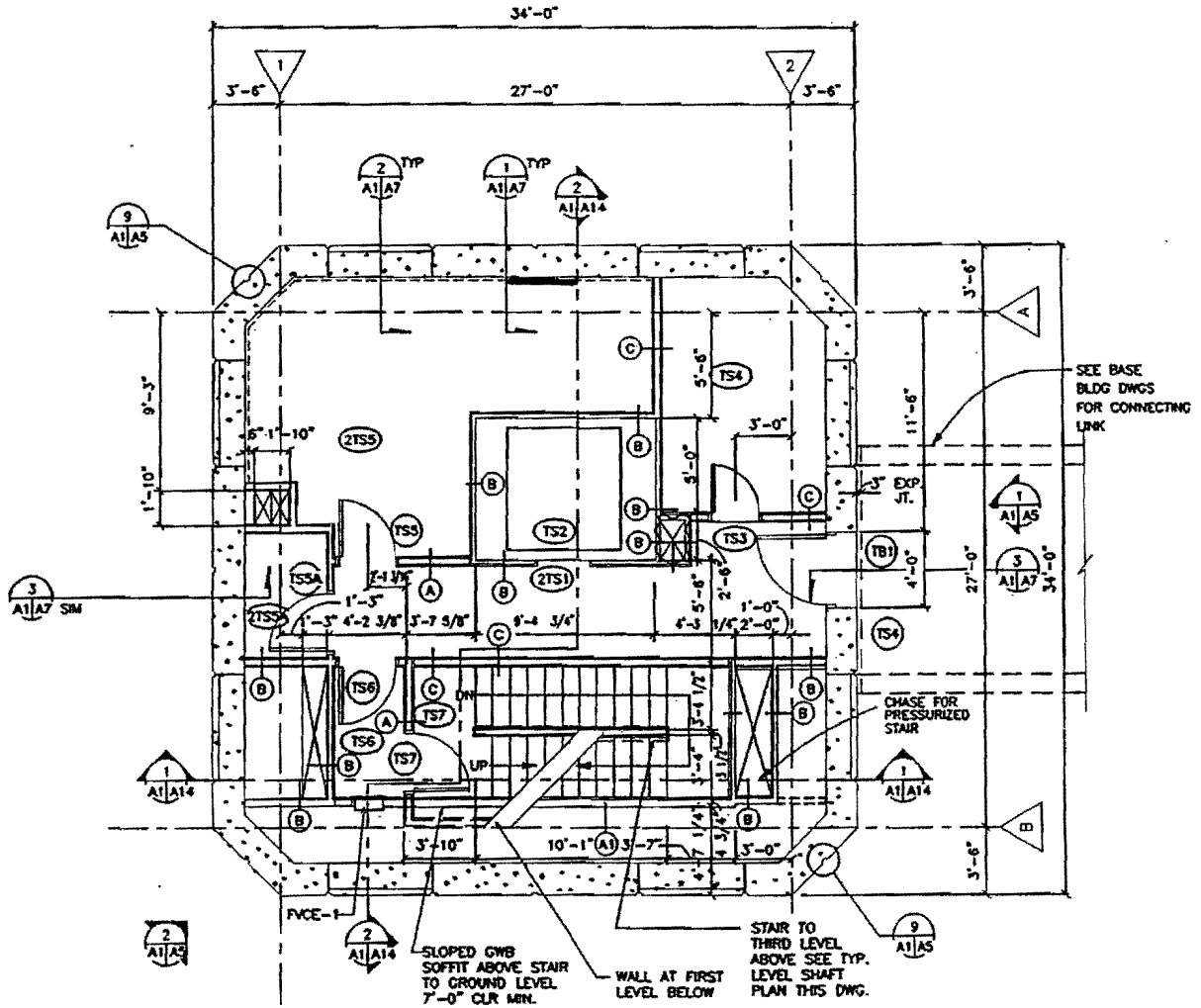

GROUND FLOOR

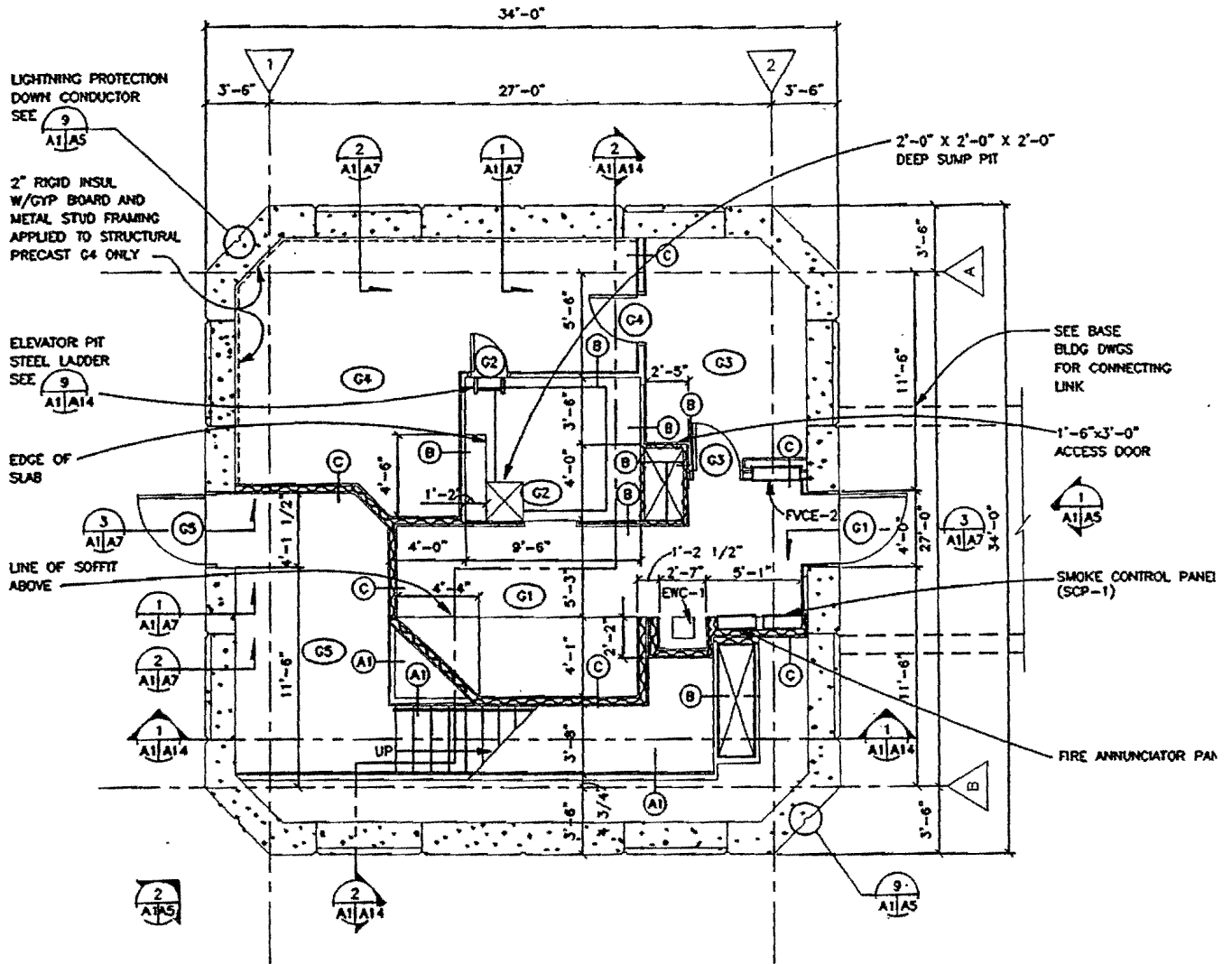

2

5

Report on Mold and Moisture Inspection
Kansas City International Airport
Airport Traffic Control Tower

Purpose, background
& inspection process.
Photos included
June - August 2006

PURPOSE

This inspection was conducted as the preliminary step in developing the Independent Solution for OPS Requirement 0682MH572. This requirement addresses the need for mold remediation and restoration in the ATCT. This report addresses only the ATCT. There is a separate OPS Requirement (0682MK545) pending solution development that addresses mold remediation and restoration in the base building. OPS Requirement 0682MH573 is pending solution development and it addresses condensation issues in unconditioned spaces within the ATCT.

BACKGROUND

Visible mold growth was discovered on gypsum board walls in the 5th, 6th, and 7th floors of the ATCT in 2003. The initial analysis and inspection showed that the source of water contributing to the mold growth was water infiltration through building caulk joints. This water could be observed during or after periods of rain trickling in through the concrete walls where sections of precast and or cast in place concrete butted together. During this inspection, discolored gypsum board was found on the 10th floor and added to the scope of work. At this time, the SSC also indicated that some walls in Room G4 of the tower had become wet during fire sprinkler testing and maintenance and had visible mold growth. Personnel involved in fire life safety projects at the ATCT were consulted and indicated that no visible mold was seen in the elevator shaft during their inspection. Engineering designs were completed to address the water infiltration and mold remediation and restoration. The building joint sealant project included recaulking all of the joints on the exterior of the ATCT and the project was completed in the Fall of 2004. Mold remediation and restoration began immediately after completion of the caulking project. During the performance of the remediation work some smaller areas of additional mold were discovered on the 7th, 8th, and 11th floors and significant amounts of mold were discovered on the 10th floor once removal of the discolored gypsum board began. All areas of visible mold were addressed on the project and the work was completed in December 2004.

In January 2005, a large water puddle was found on the floor in the middle of room 10TS5. Since it had been there long enough for some of the water to evaporate, it was not possible to tell if it had originated from behind the north or west walls of the room. Prior to this occurrence, the building had been monitored by personnel in the environmental unit and no building leaks were found. The building was also inspected during heavier rains later in 2005 by personnel in the environmental unit and ACE-472 and no building leaks were found. Frosting or condensation on the interior face of the concrete walls of the tower was considered as a possible source of moisture. Personnel working on fire life safety upgrades at the tower had previously reported instances where there was moisture or frost on the interior face of the concrete walls and they were unable to install firestop caulk on these surfaces. In order to further investigate the condensation and frost potential, ACE-470 purchased GE Protimeters, Model 4100. This device records ambient temperature and humidity as well as two surface temperatures. The data can be downloaded and analyzed through the GE software that will calculate the dew point temperature.

Whenever the surface temperature is at or below the dew point, condensation will occur and frosting will occur when the temperature is at or below freezing. Data collection began for the winter months in October 2005. In December 2005, an access panel was added on the west side of the 10th floor to allow visual observations and monitoring of temperature and humidity in the concealed space behind the gypsum board walls. Water was found dripping off of the steel beam above the new opening and a puddle of water was found on the floor in room 10TS5. Shortly thereafter, further investigations were conducted to locate the source of the leak and much more water was found. Significant amounts of water were found running down the exterior face of the elevator shaft in room 10TS5 and the fireproofing on the metal decking above was wet. The conditions on the 11th floor were similar and water was found puddled in the 11th floor corridor adjacent to the elevator door. Large quantities of standing water were found on the concrete floor slab under the raised access floor in the subjunction level equipment room, SJ1. Visible mold was found on the gypsum board walls under the raised floor. The source of water was found to be a clogged floor drain under the raised floor where water is discharged from a humidifier serving the equipment room. It appears that the drain had been clogged for some time and backed up during periods when the humidifier was frequently being used. ESU personnel cleared the drain and set out fans to help dry the building materials that had become wet. This drain line and trap are uninsulated and are routed through unconditioned spaces on the 11th floor. It is possible that the trap or drain line could freeze during cold periods and cause the backup of water under the raised floor in the Subjunction level Equipment Room. This occurrence and the unresolved issues with condensation and unconditioned spaces within the tower lead to the development of the requirements identified above.

INSPECTION PROCESS

The inspection was performed by Ed Winkler, Civil Engineer, ACE-472 and Barbara Hebert, Certified Industrial Hygienist, ACE-471. Tom Orr, Mechanical Engineer, ACE-472 has also been involved in review and analysis of the mold and moisture issues and will be developing the independent solution for the problem of condensation in unconditioned spaces in the ATCT, OPS Requirement 0682MH573. The inspection was conducted between June and August 2006. Additional periodic inspections were conducted as necessary to monitor conditions in the ATCT.

It was known that the mold and moisture inspection needed to be very thorough to identify to the maximum extent possible any water sources that might contribute to mold growth within the facility as well as to fully address the quantity of affected building materials that must be addressed in the remediation and restoration project. Moisture is always a precursor to a mold problem. If the sources of water are not identified and corrected, mold growth will continue. Any remediation effort undertaken without first solving the cause of the moisture problem will be futile and costly. Lessons learned from the previous mold remediation project showed that the inspection process needed to be more thorough and invasive than a visual inspection of the surface of walls. The quantity of mold was typically more on the concealed layers of gypsum board in a fire rated wall assembly since they remained wet for longer periods of time than the visible surface layer. The majority of walls in the ATCT are fire rated partitions and consist of up to 4 layers of gypsum board.

Prior to beginning the on site inspection, a thorough review of the facility drawings (series 7893) was conducted to identify potential problem areas that might contribute to the moisture problems within the facility. This review looked at all potential problem areas such as roofs, walkways, storm drains, flashing details, window systems, building openings such as at louvers, floor drains, wall construction details, etc. A copy of the "Report on Exterior Building Envelope and HVAC Conditions, Detroit Metropolitan Wayne County Airport, Airport Traffic Control Tower (Prepared by the engineering firm DMJMH&N, dated April 24, 2005) was read and analyzed since that tower is of similar construction and has mold related problems. Any potential problem areas identified in the report that were not considered in the facility drawing review were noted as items requiring inspection. The facility drawing review and that of the DTW ATCT report lead to the creation of a checklist that was used during the inspection to track all items requiring observation during the physical walk through of the tower from top to bottom.

Past experience proved that the inspection would need to be more thorough than that performed originally in 2004. As a result, the inspection included pulling back vinyl cove base on gypsum board walls at any area that could have been wet at some time. This included locations such as walls that Tee into exterior walls, walls adjacent to floor drains, near any pipes showing signs of leaks, or at any location that showed signs of water stains or prior leaks from any source. Checking behind the cove base is typically a good location to identify problems since any water leaks will accumulate at the floor level and the wall will likely remain wet for longer periods of time and allow mold growth to occur on the paper surfaces of the gypsum board. Core samples of gypsum board were taken at suspect areas to detect visible mold on concealed layers of gypsum board and utilized to help define the remediation limits. Bulk samples and tape samples were taken and sent to an outside lab at all locations of suspect mold growth where it was not visually obvious that mold was present. Photographs documenting problems found are included in appendix 1. The location and approximate quantity of all mold found through the visual inspection or lab analysis were documented. The lab results are included in appendix 2 and the quantities of materials requiring mold remediation are included in appendix 3. Additional work required is identified in appendix 4. This includes any items to correct potential moisture or water related problems, work to minimize or prevent the future recurrence of mold growth, testing (and repair if necessary) and reinsulation of drain lines with water stained insulation, adding access panels to allow visual inspection of concealed locations, etc. Appendix 5 identifies additional inspections, testing, and engineering analysis that must be completed to fully address mold and moisture related problems or issues.

It should be noted that some mold might be present in the facility that hasn't been detected. The majority of the mold growth is on gypsum board concealed behind the visible layer. Some of the mold is located in areas of the tower that have no access for inspection. Core samples of walls were approximately 2" in diameter and taken at locations that showed signs of being wet at some time so it is possible that some areas may have been missed where there were no visible signs of water damage. Larger access holes were cut through walls to expose concealed areas where it seemed likely that water leaks could occur or may have occurred in the past. The quantities of materials requiring remediation were based on good engineering judgment and the intent is to err somewhat on the high side without needlessly driving up the project cost. When the contaminated materials are removed during remediation, it will be possible to view the concealed layers of gypsum board during the inspection process and verify the completeness of the

remediation at these locations. If additional work is found to be required, the contract will need to be modified to address it. The size, complexity of the construction, and the inability to view or access all areas of the tower make it extremely difficult to track the origin and path of all sources of water within the facility. Water sources include building envelope leaks (roofs, drains, walls, openings, etc.), condensation, pipe leaks, problems with drains, etc. Assumptions and best judgment are often required to analyze and assess the existing building structure and its moisture related problems.



Photo 1: ASDE Penthouse, North Wall at Roof Beam.

There is no insulation on the bottom and backside of the beam or the $\frac{1}{4}$ " steel roof deck adjacent to the insulated panel wall. The gap between the beam and the wall allows warm air to contact the cold steel surfaces. The uninsulated steel is the likely point where condensation is occurring as shown by the heavy white residue visible on the wall near the bottom of the beam in the ASDE Penthouse.

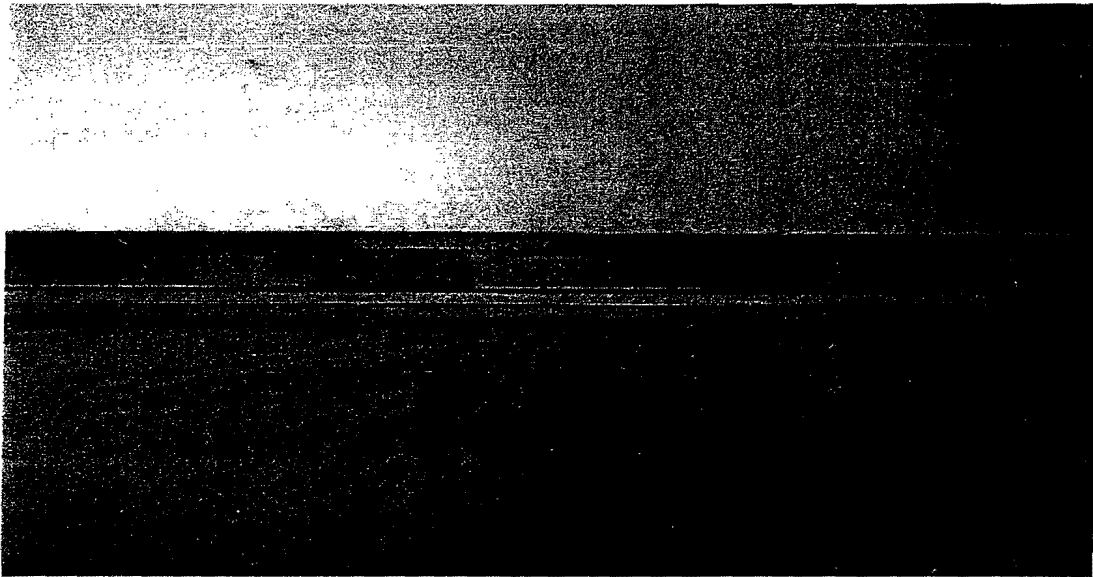

Photo 2: ASDE Penthouse, South Wall Between Beam and IMP.

This view is looking up at the $\frac{1}{4}$ " uninsulated steel roof deck between the insulated metal panel and steel beam. Rust, water stains, and white residue are visible on all surfaces from condensation and frosting.



Photo 3: ASDE Penthouse, East Wall, South of Door.

The white residue shown on the floor of the ASDE Penthouse appears to be caused by condensation on the insulated metal panel and uninsulated steel beam and sections of roof deck.



Photo 4: ASDE Penthouse, Floor Hatch.

The plastic covering the steel equipment floor hatch shows air infiltration from the Cab. In the winter months, this likely provides a source of warm humid air, which increases the potential for condensation on cold surfaces in the Penthouse.

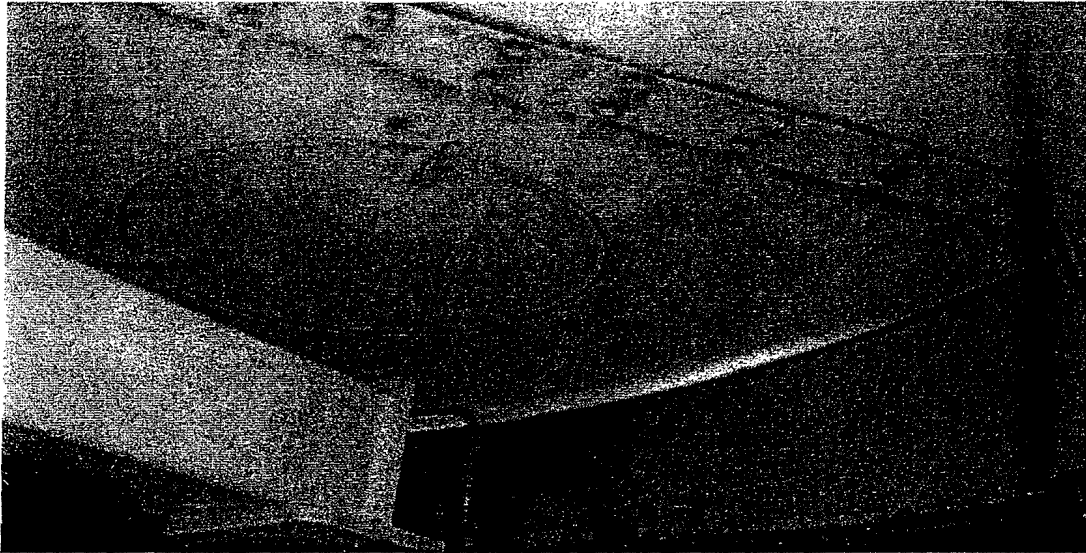

Photo 5: ASDE Penthouse, Antenna Opening.

The antenna opening is shown in the ceiling of the room. Rust and water stains are visible on the surrounding walls from condensation or frosting.



Photo 6: Cab Level, Interior of Door to Outside Walkway.

A gap in the doorframe weather-stripping and flashing that improperly slopes towards the door, have allowed water to enter the stairway near the door. The water has wicked up adjacent gypsum board causing it to deteriorate and has also resulted in mold growth behind the vinyl base.

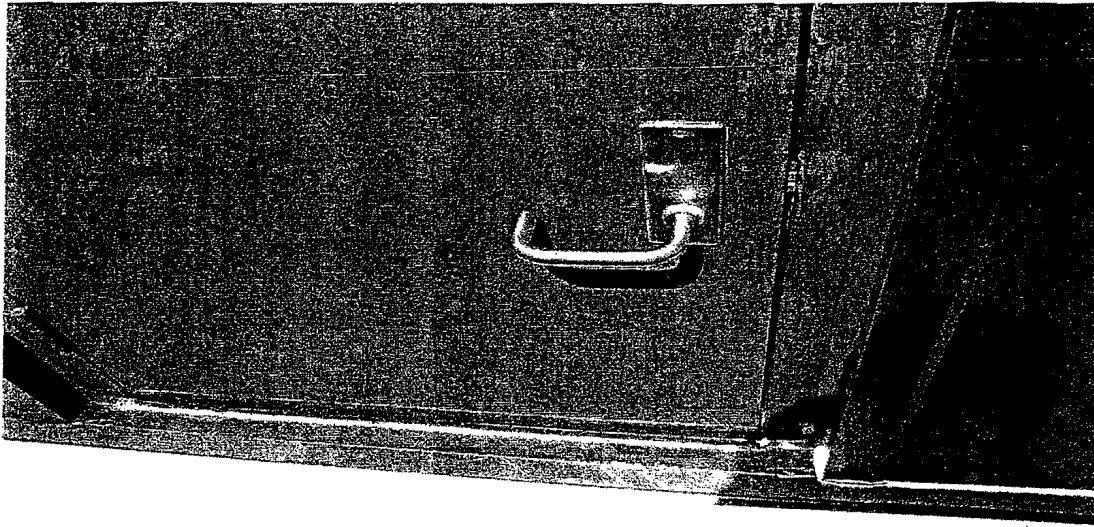

Photo 7: Cab Level, Exterior of Door by Outside Walkway.

An excessive gap is shown on the latch side of the door that allows water to enter the building. The metal flashing also has a slight slope towards the door and threshold instead of towards the exterior.

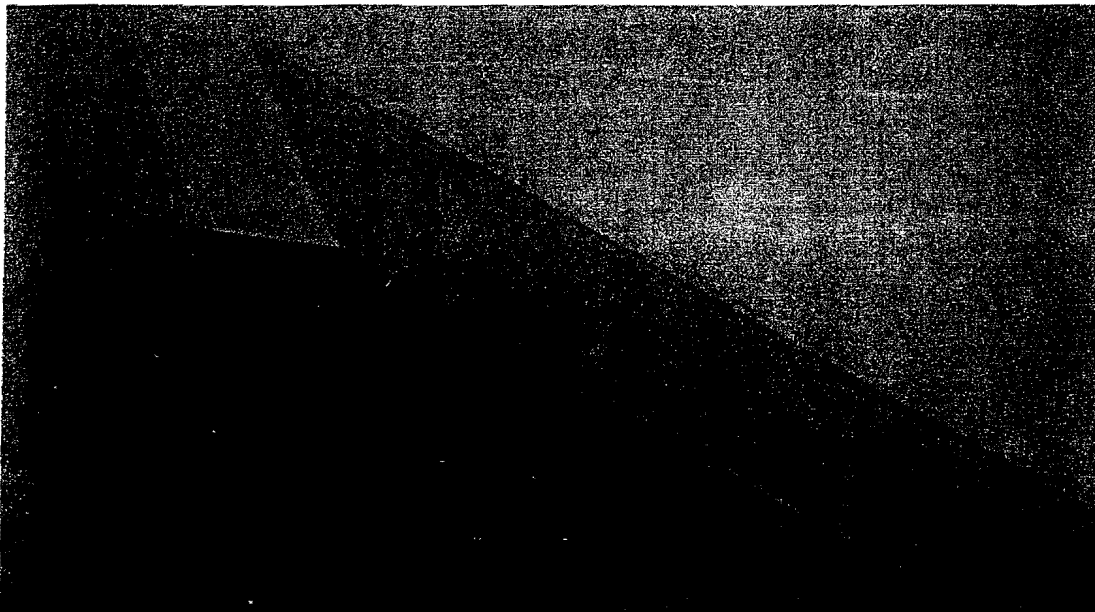

Photo 8: Below Cab Level, West Side of West Stair Wall.

Alternaria (31 counts/cm²), *Ascospores* (46 counts/cm²), *Pithomyces* (15 counts/cm²), and *Smuts* (15 counts/cm²) were detected on the west side and middle of the west stair wall. A small-scale test showed that removing the dust and cleaning the underlying surface with a detergent was not completely effective in removing the mold, therefore, more stringent biocide cleaning measures will be needed.

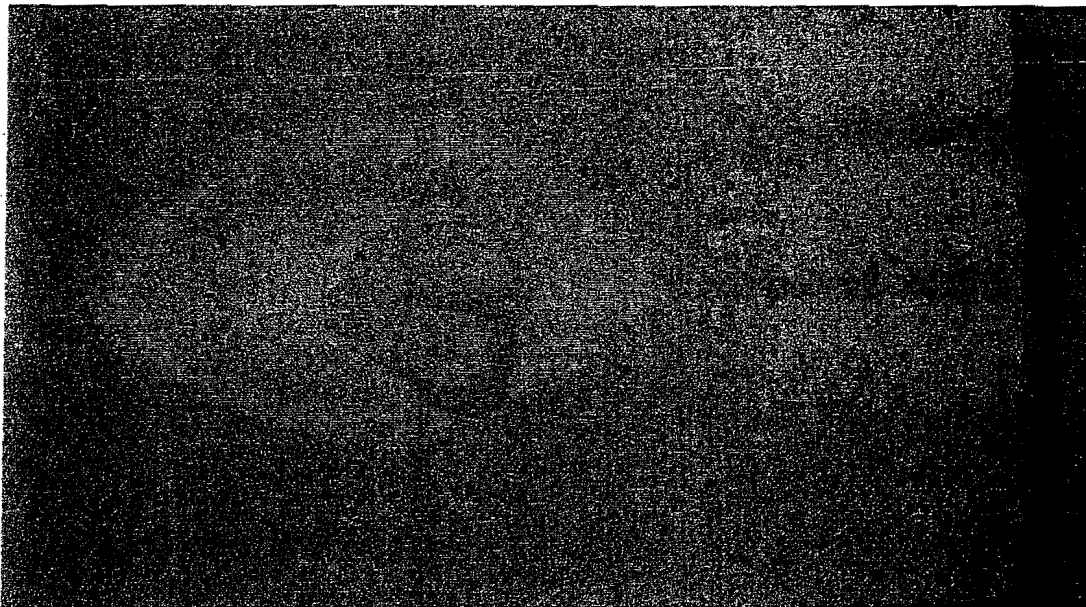

Photo 9: Cab Level Stairs, Water Stain on Sloped Ceiling.

Water stains are shown on the sloped ceiling under the Cab Level sink due to past water line or drain line leaks. Cleaning out a clogged drain line appears to be a major source of the water damage.



Photo 10: Cab Level, Back Side of Gypsum Board under Sink.

Mold is visible on the gypsum board under the sink due to past drain line leaks and possibly past water line leaks. Removal of the cap to clean out a clogged drain line also appears to have been the major source for water leaks/stains here and below in the Cab stairs.

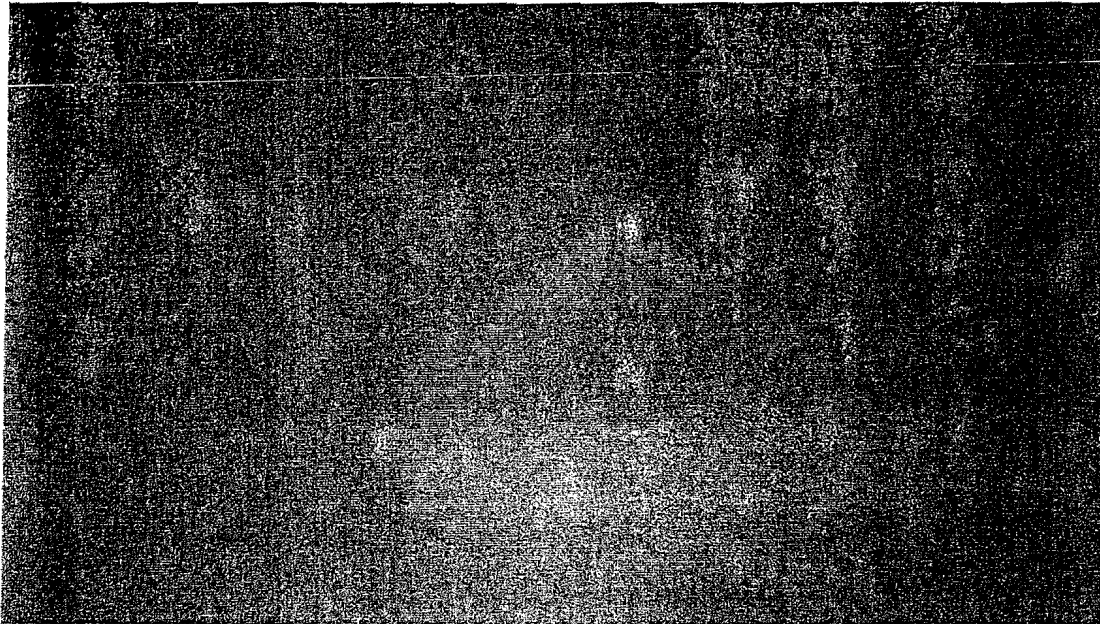

Photo 11: CA2 Landing, South Wall, Bottom of Soffit.

The water stain shown was likely caused by drain line leaks from the sink in the Cab Level.

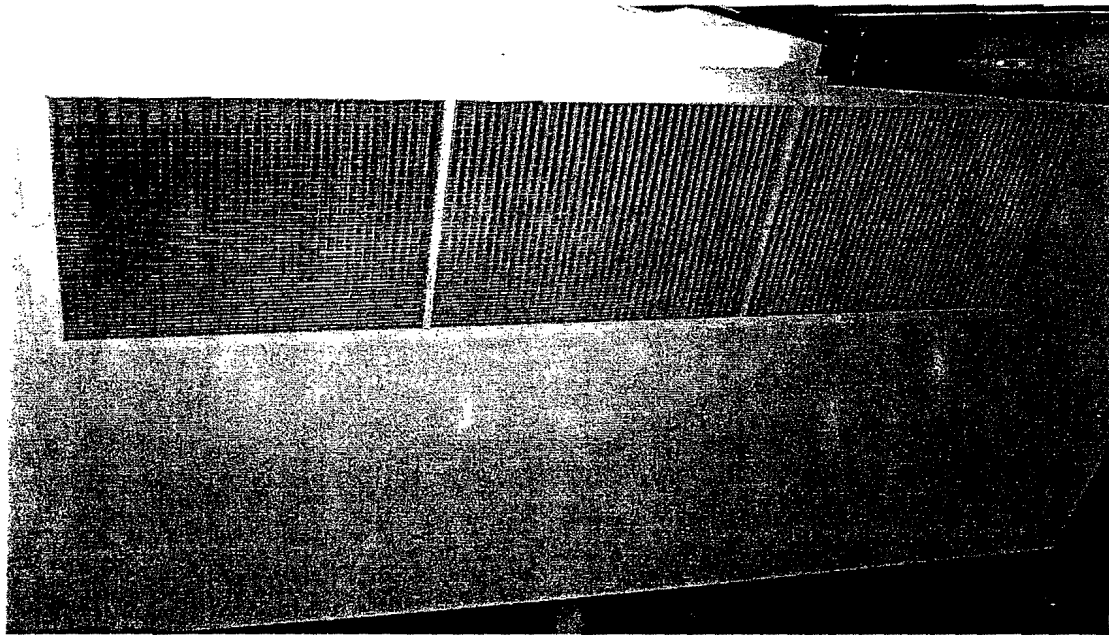

Photo 12: Below Cable Access Level, Return Air Grill.

Debris from this return air grill has contaminated adjacent walls as shown in Photo 8. Dust provides a food source, which sustains the growth of mold.

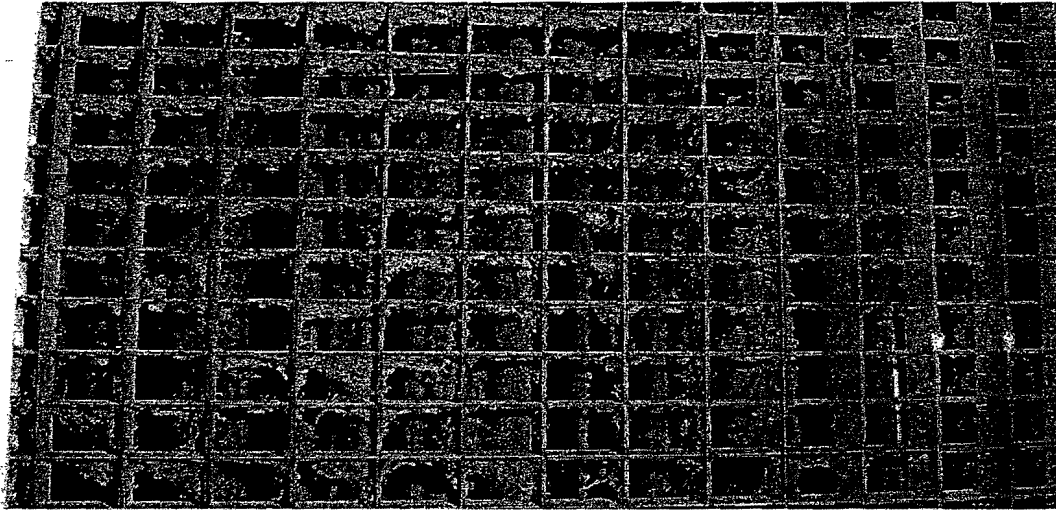

Photo 13: Below Cable Access Level, Dirty Return Air Grill.

A close up of the return air grill from Photo 12 above shows a thick lading of dust, indicating the need for an increased frequency of housekeeping measures.

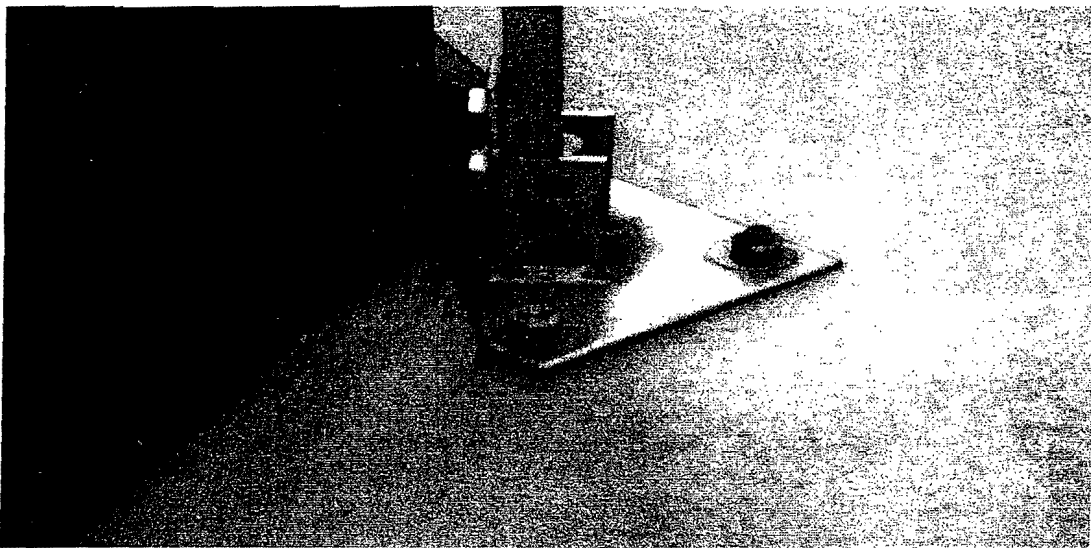

Photo 14: Cab Level Walkway, Penetrations in Floor.

The roof system on the walkway consists of a waterproof membrane on top of the structural concrete deck. The membrane is covered with a concrete topping slab that is coated with a waterproof deck coating. The membrane is installed utilizing typical roofing details and is the primary waterproofing component. The membrane terminates at the drains and is clamped in place at the drain bodies as shown above. In this type of system, the drain bodies have seepage holes to allow any water that gets through the waterproof deck coating and concrete topping slab, to follow the membrane and drain from the roof through the seepage holes into the storm drain piping. If the membrane is not fully compressed under the clamping collar into the drain body, a leak can occur.

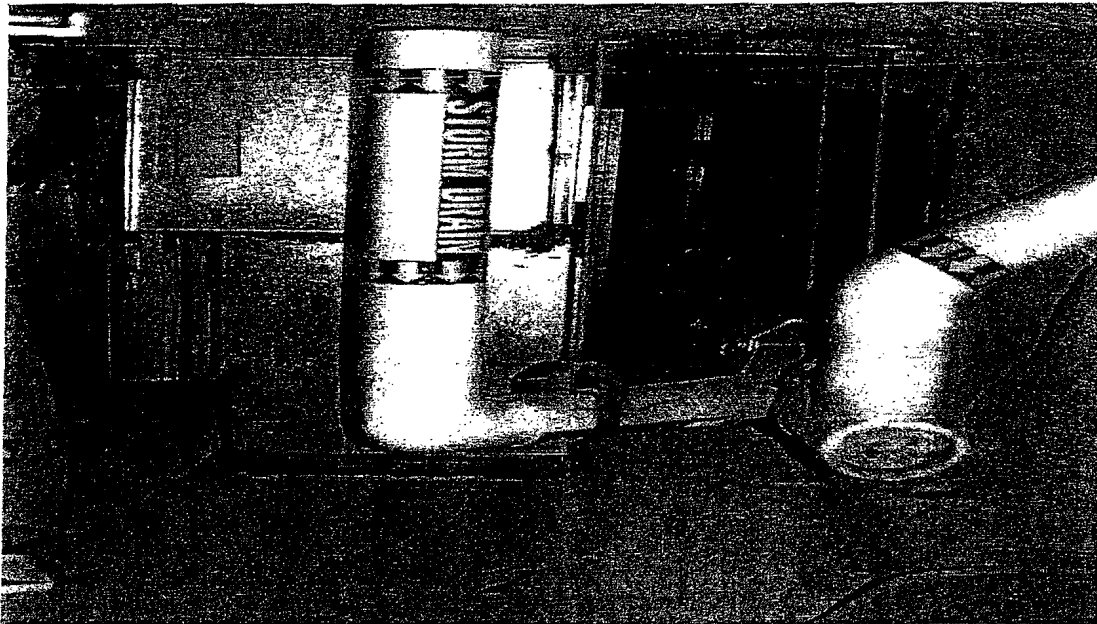

Photo 15: Cable Access Room (CA1).

One of the storm drain pipes in Room CA1, directly beneath the drain body, had water stained insulation as shown above. The stained insulation could be caused by a leak getting under the membrane and following the structural concrete slab to the opening around the drain body, a leak at the connection between the drain body and drain pipe, or possibly from condensation due to a damaged vapor barrier jacket on the insulation.

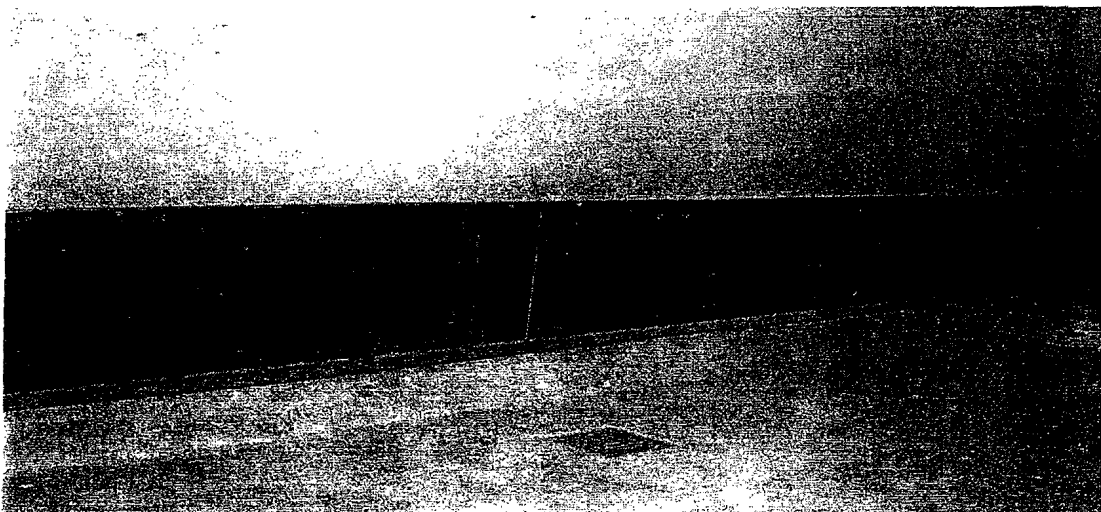

Photo 16: Cable Access Level, Northeast Wall.

Water stains are shown on the metal panel on the northeast wall, similar to that found on the IMP walls in the ASDE Penthouse. The potential sources of this water are condensation or building leaks.



**Photo 17: Cable Access Level, Outer Portion,
Northeast Wall, Interior Face of IMP Siding.**

Water stains are shown on the metal panel, similar to that found on the IMP walls in the ASDE Penthouse. The potential sources of this water are condensation or building leaks.



Photo 18: Junction Level; Bottom of Handrail Post.

The waterproofing on the Junction Level walkway is identical to the roofing system on the Cab Level walkway. There is some delamination of the waterproof coating on top of the concrete topping layer and some peeling at the handrail posts as shown above. No membrane flashing is evident around the handrail post and there appears to be a pliable caulk-like material under the waterproof coating around the post. This could be a source of leaks.

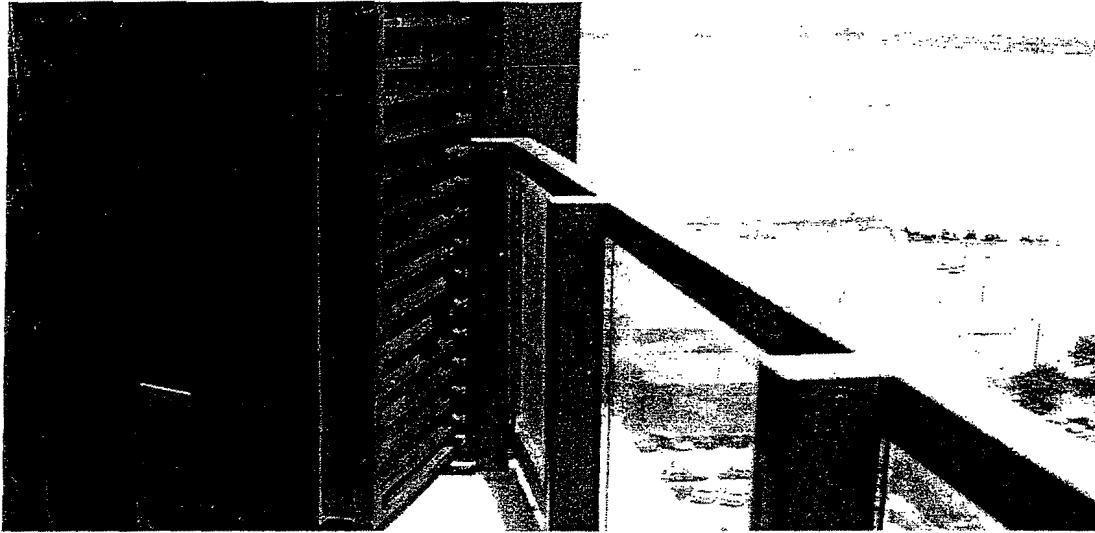

Photo 19: Junction Level, Holes in Hand Rail Post.

Each of the railing posts on the walkways has a hole in the side near the top that could allow rather small quantities of water into the tube and down into the building as shown above. The holes appear to be vent holes from when the posts were hot dip galvanized during fabrication. The holes may allow water to enter the building behind the walls of the SubJunction Level.



Photo 20: Junction Level, Mold-Containing Dust on Wall of Elevator Door.

Alternaria (31 counts/cm²), *Ascospores* (15 counts/cm²), *Aspergillus* (662 counts/cm²), *Basidiospores* (31 counts/cm²), *Cladosporium* (92 counts/cm²), *Epicoccum* (15 counts/cm²), *Pithomyces* (15 counts/cm²), and *Smuts* (31 counts/cm²) were detected above the elevator door. Biocide cleaning measures will be required in the area represented by this sample location. Potted plants are a known contributor of *Aspergillus* spores to the overall ambient concentration. The plants located in this area may be partially responsible for the elevated count reported.



Photo 21: Junction Level, Northwest Corner of Walkway.

A rusty flashing is shown in the northwest corner of the walkway, indicating improper drainage of water in the area.

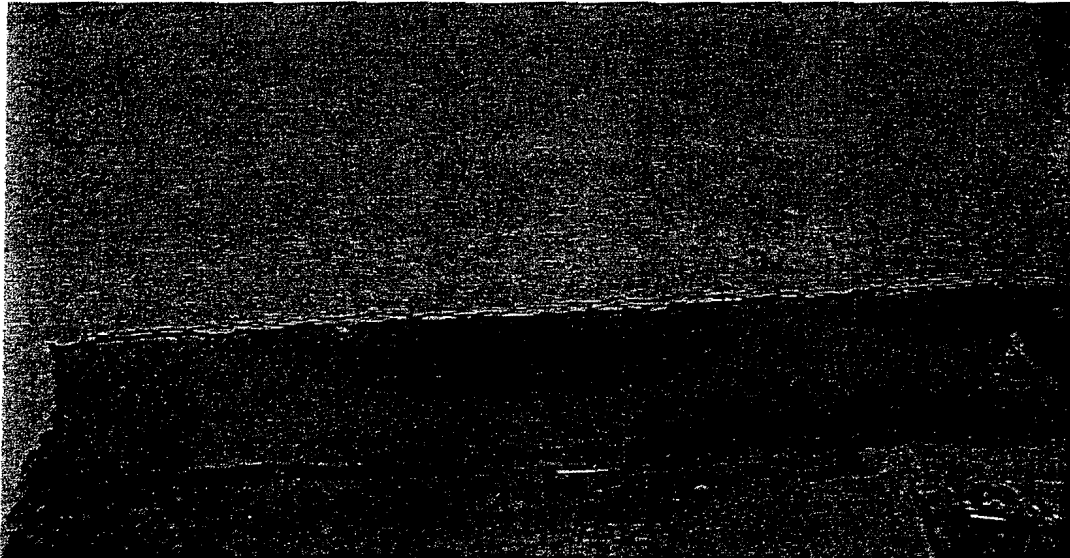

Photo 22: Junction Level, Water Stain on North Walkway.

A water stain is shown on the north walkway, indicating improper drainage of water in the area.

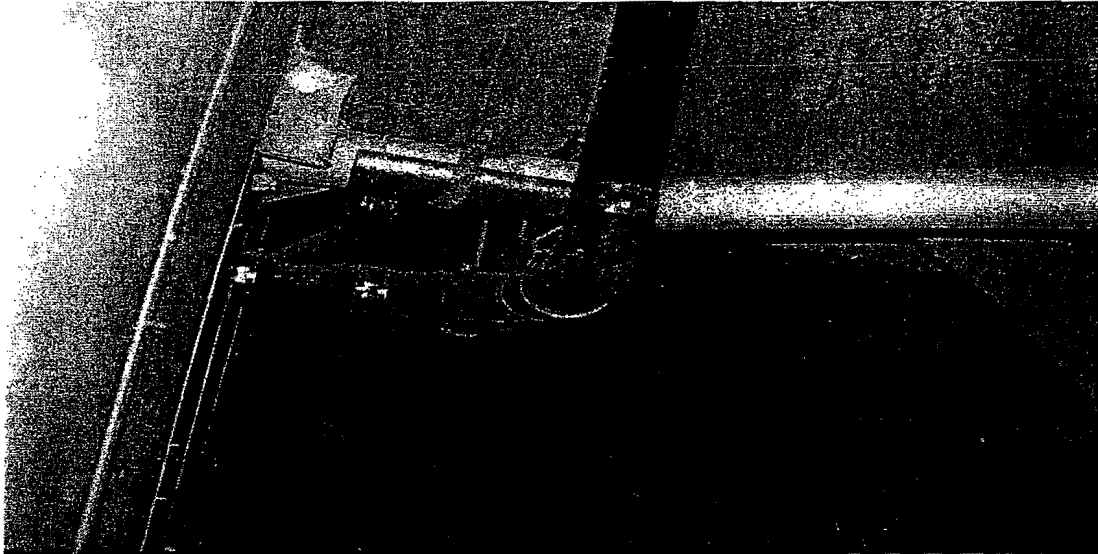

Photo 23: Sub Junction Level, Concealed Space between East 2-hour Shaft Wall of Room SJ1, looking North.

This area was evaluated in order to verify the storm drains were not leaking as well as determine the presence of mold.

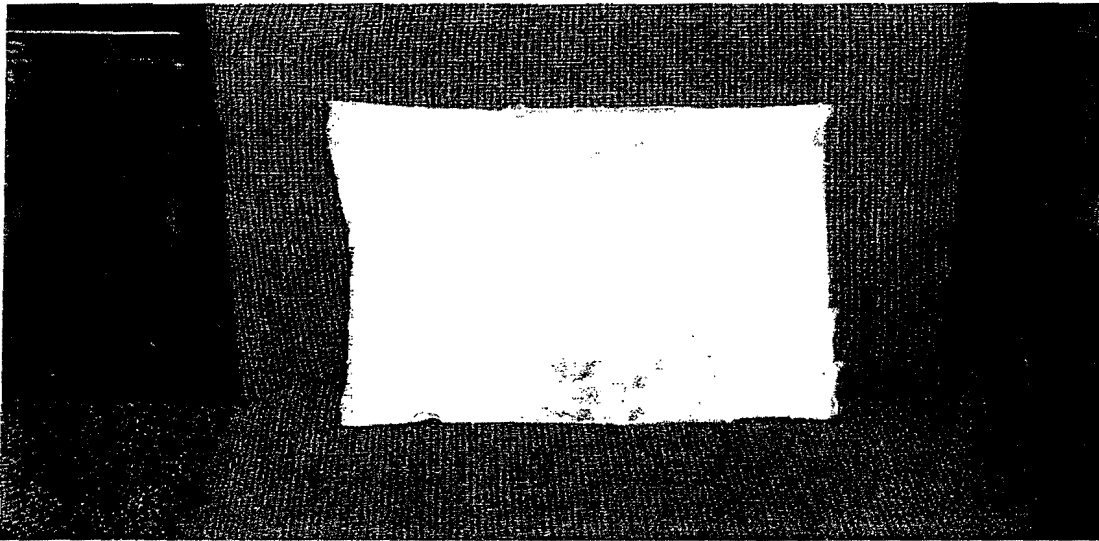

Photo 24: Sub Junction Level, Mold on Room SJ1 side of 1" GWB cut from the West Wall, South end.

Four openings approximately 12" square were cut through the perimeter 2-hour rated shaft wall above the suspended ceiling on the east, north, and west walls to inspect the concealed spaces located underneath the Junction Level walkways and between the sloped architectural precast concrete panels and the perimeter gypsum board walls. A mold-contaminated section of the shaft liner shown above was cut from the west wall, south end.

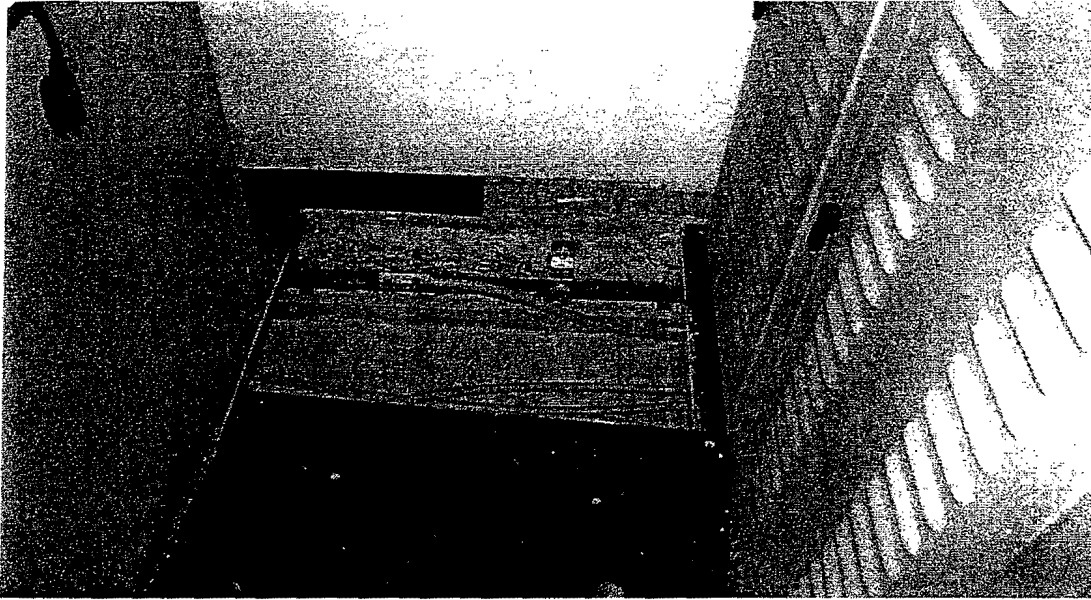

Photo 25: Sub Junction Level, Room SJ1, West Wall.

Inspection of the gypsum board walls below the raised access floor in the Equipment Room SJ1 revealed heavy concentrations of black mold as shown above. It can be attributed to the water from the humidifier and plugged floor drain in the southwest corner of this room.

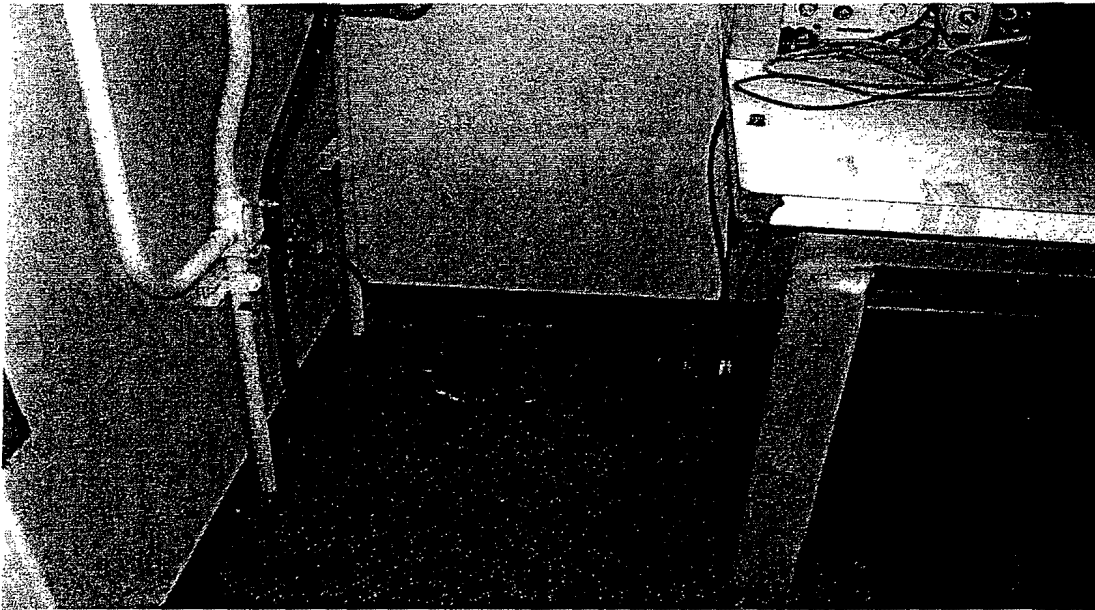

Photo 26: Sub Junction Level, Room SJ1, Southwest Corner.

Areas of yellow discoloration in the painted finish as shown above and visible mold were found up to three feet above the raised access floor.



Photo 27: Sub Junction Level, Room SJ6.

Air shaft SJ6 has an area floor drain pipe, serving the concrete slab adjacent to the microwave fabric on the Junction Level, which discharges over the top of each floor drain as shown above.

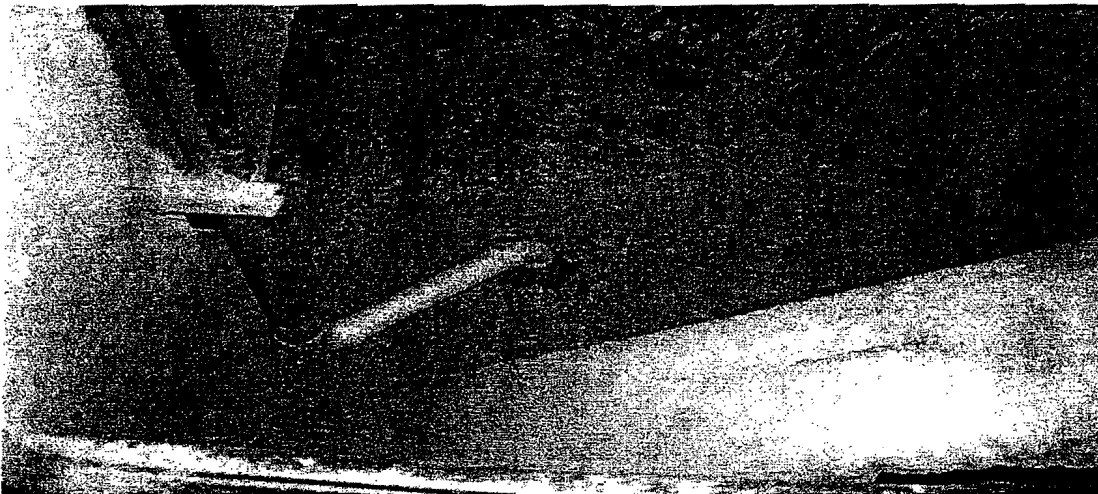

Photo 28: Sub Junction Level, Room SJ8.

Air shaft SJ8 is the outside air intake for the air-handling unit in the SubJunction Level Mechanical Room. The fireproofing debris present may block the drain line. Pigeon staining and droppings were also observed in the bottom of the shaft. The mold *Aspergillus* grows in damp bird debris, as well as possibly harboring other infectious agents such as *Chlamydophila psittaci*, *Cryptococcus neoformans*, and *Histoplasma capsulatum*. No pathogenic compounds were detected from the sample collected from this location.

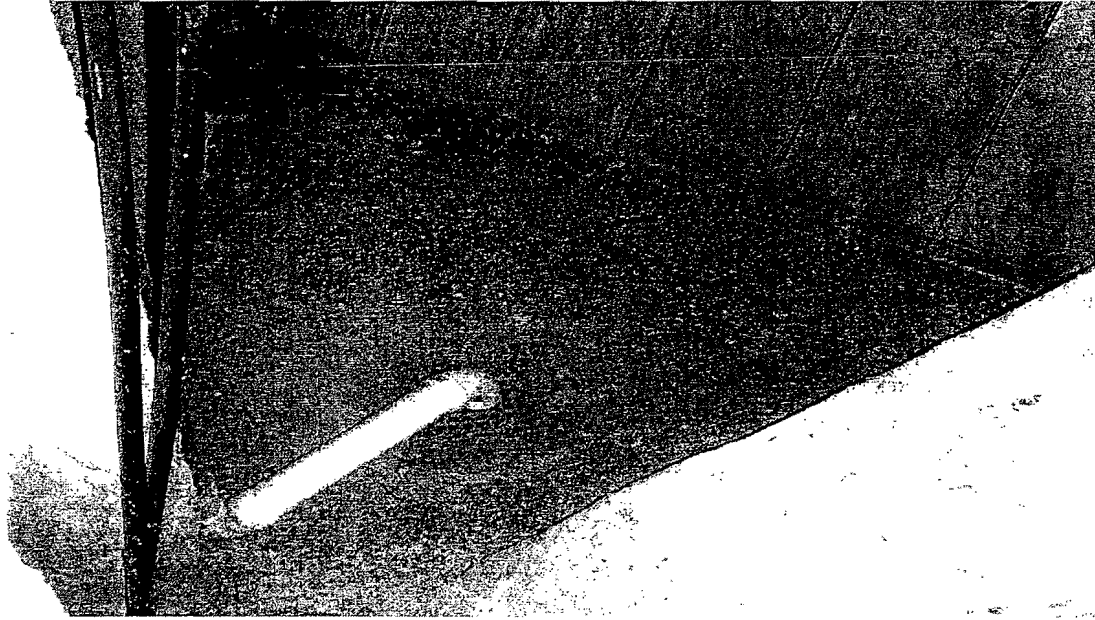

Photo 29: Sub Junction Level, Room SJ6.

Fireproofing debris and pigeon staining and droppings were observed in the bottom of air shaft SJ6. No pathogenic compounds were detected from the sample collected from this location.



Photo 30: Sub Junction Level, Room SJ1, Dirty Diffuser.

A dirty diffuser is shown in Room SJ1. Diffusers and grilles must be cleaned as the dust provides a food source for mold.

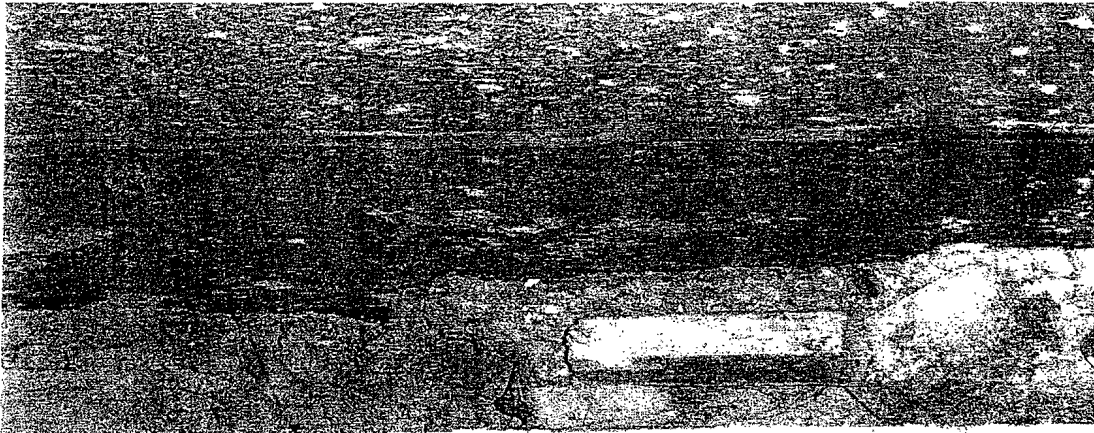

Photo 31: Debris found in 11th Floor Outer Ring.

A large quantity of scrap gypsum board was found in the void between the edge of the floor slab, precast exterior walls, and perimeter fire rated gypsum board walls as shown above.



**Photo 32: Construction Debris found in 11th Floor Outer Ring,
Back of the West wall of 11TS5.**

This debris was found in the same location as the material shown in Photo 31. Much of this material appears to be left from the building's initial construction.

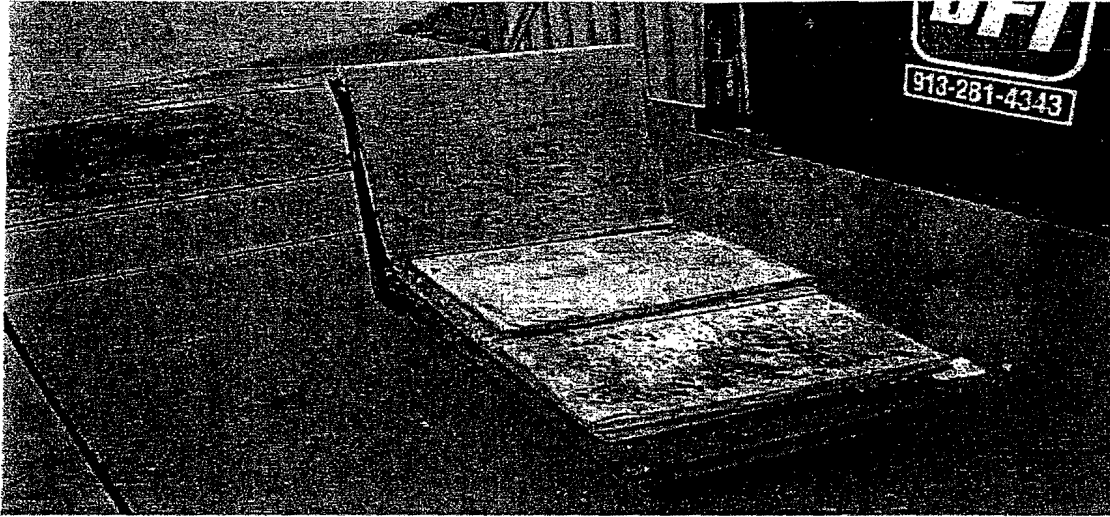

**Photo 33: Moldy Construction Debris found in
11th Floor Outer Ring, Back of the West wall of 11TS5.**

This construction debris was found in the same location as the material shown in Photos 31 and 32. Much of the scrap had large quantities of mold.



Photo 34: 11th Floor Outer Ring, Back of the West wall of 11TS5.

The debris shown in Photos 31, 32, and 33 were pulled from this location. Moisture from building and humidifier leaks lead to the growth of mold on the debris, which contaminated this area. *Ulocladium* (154 counts/cm²) was detected on the 5th panel from the South, in an area that had been biocide treated prior to sampling. After subsequent re-cleaning, *Pithomyces* (31 counts/cm²) was detected in the same area. After a 3rd biocide cleaning, however, all mold spore concentrations were below the limit of detection.

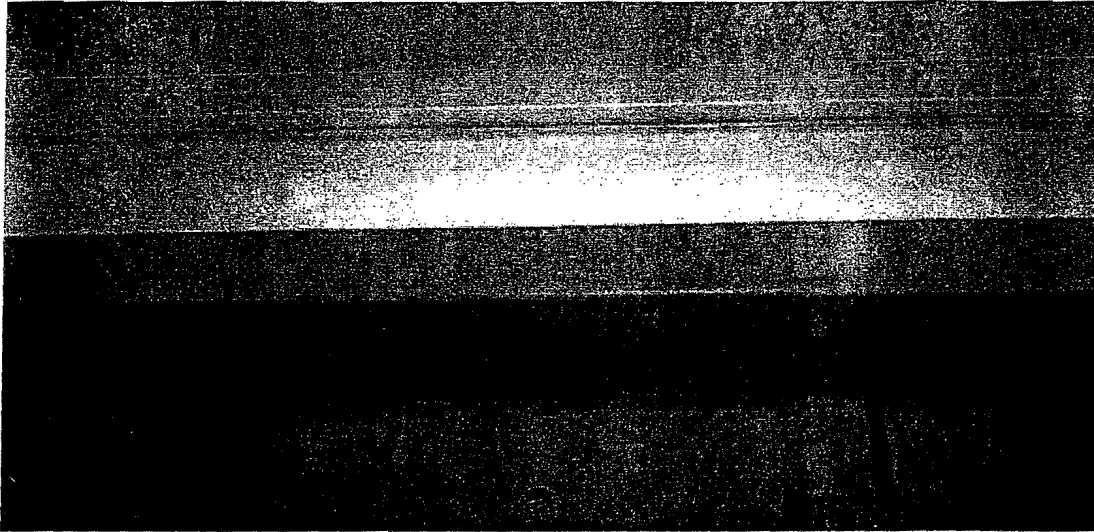

Photo 35: 11TS1, Mold-Containing Dust on Wall of Elevator Door.
Alternaria (77 counts/cm²), *Ascospores* (15 counts/cm²), *Cladosporium* (31 counts/cm²), *Epicoccum* (15 counts/cm²), *Pithomyces* (31 counts/cm²), and *Smuts* (31 counts/cm²) were detected above the elevator door. Biocide cleaning measures will be required in the area represented by this sample location.

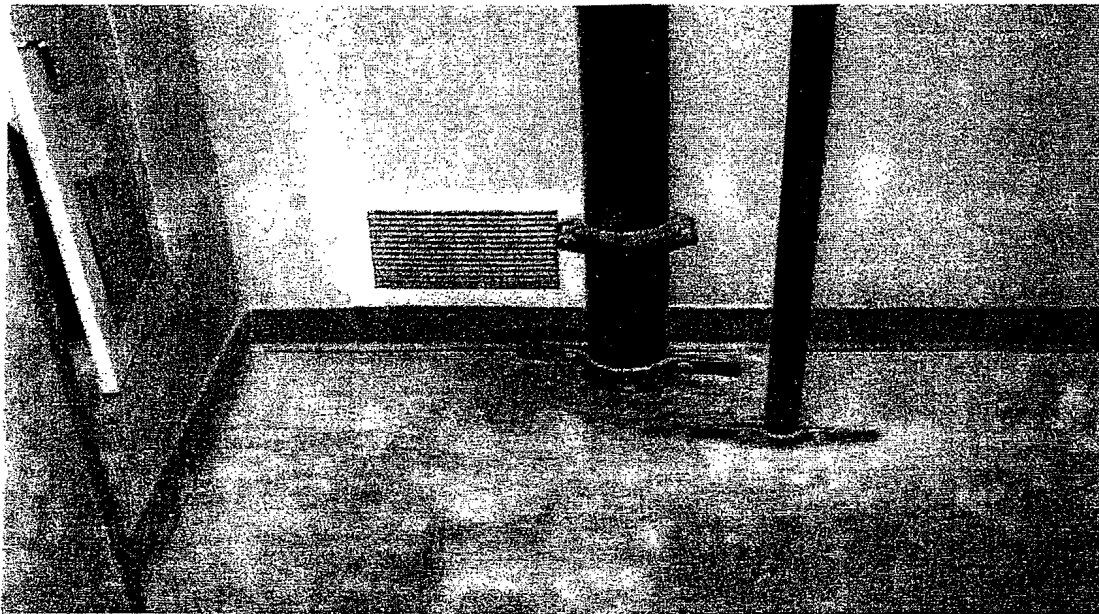

Photo 36: 11TS6, Southwest corner.
Water stains and discoloration were found on the concrete floor and gypsum board wall of stair vestibule 11TS6. A union and short section of pipe in the fire sprinkler line was unpainted and had been replaced after the tower was constructed. It was confirmed that this pipe had leaked and as repaired. Peeling back the vinyl base revealed visible mold.



Photo 37: 11TS5, West Wall, Drilled Core South of Door.

Mold is shown on the back of the 1st layer of sheetrock and on the front of the concealed layer in Room 11TS5. This area was known to have had water leaks, therefore the base was pulled and cores were drilled in order to evaluate the possible presence of mold.

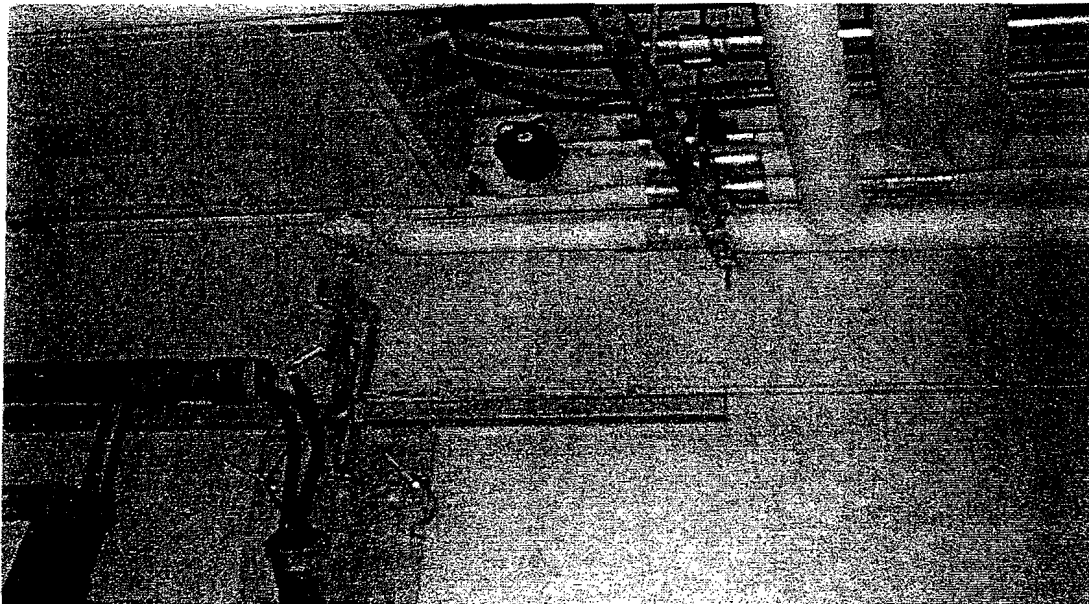

Photo 38: 11TS5, East Wall Fan Coil Unit.

Pipe insulation is shown with visible water stains in Room 11TS5. Water stained insulation should be checked regularly if in close proximity to sheetrock.



Photo 39: 10TS5, NW Corner.

Mold was found behind the vinyl base in this location of Room 10TS5. The core openings shown in the upper left corner and middle of the photo provide an example of how holes are drilled to estimate total quantities of mold for the subsequent remediation. It appears that all mold found on this level was the result of water damage from the clogged floor drain on the Sub Junction level.

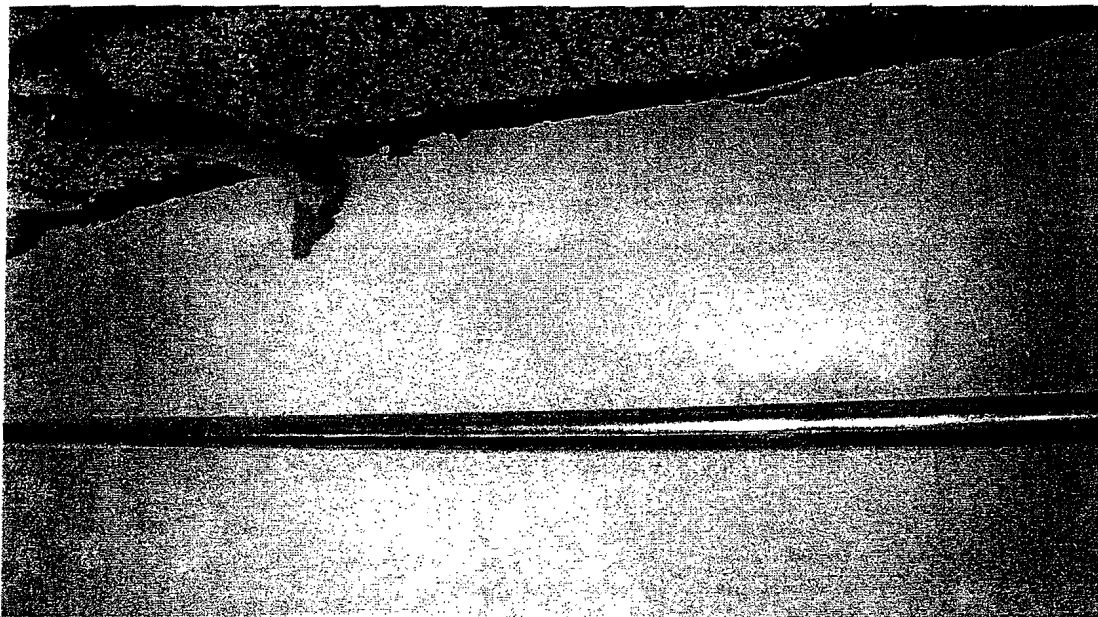

Photo 40: Yellow stained South Wall (Elevator Shaft) of 10TS5.

The yellowed areas shown on the sheetrock in Room 10TS5 often indicate the initial stage of underlying mold growth. In this case, however, the core sample obtained was negative.

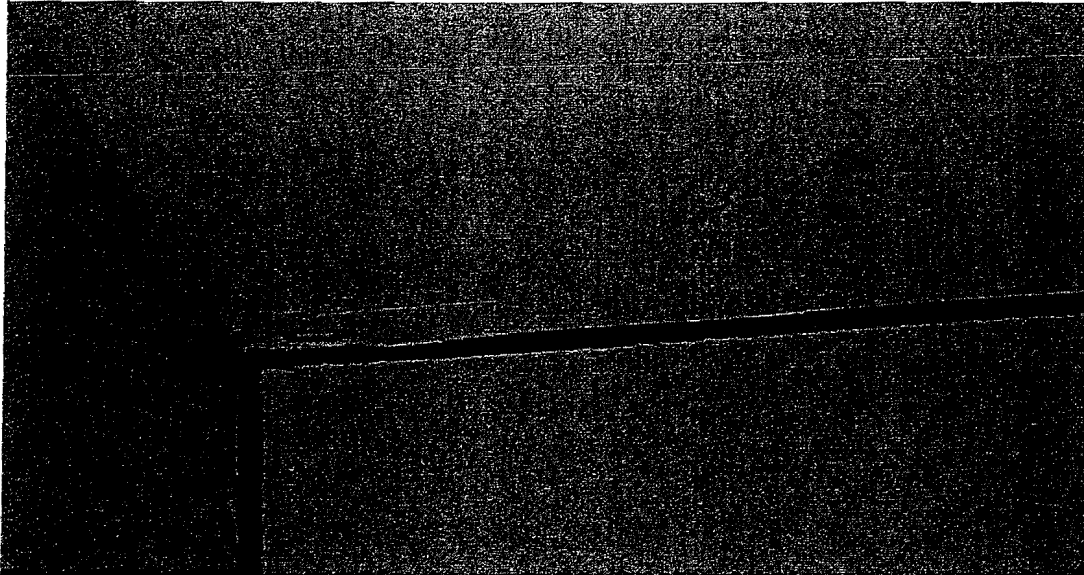

Photo 41: Water stained ceiling of 9TS1, West End.

Visible water stains, several inches wide, were found on the perimeter of the ceiling of corridor 9TS1, adjacent to the west exposed precast concrete wall and the south gypsum board wall, adjacent to the stair vestibule and stairway as shown above. The stain extends the full length of the west wall and the taped joint on the gypsum board ceiling was peeling loose. The water stain then followed along the south wall toward the east for approximately 10 feet.



Photo 42: 9TS1, Above Ceiling, South Wall.

The area above the corridor ceiling was inspected through the access panel. Some water stains were found on the unfinished fire taped south wall above the ceiling as shown above.

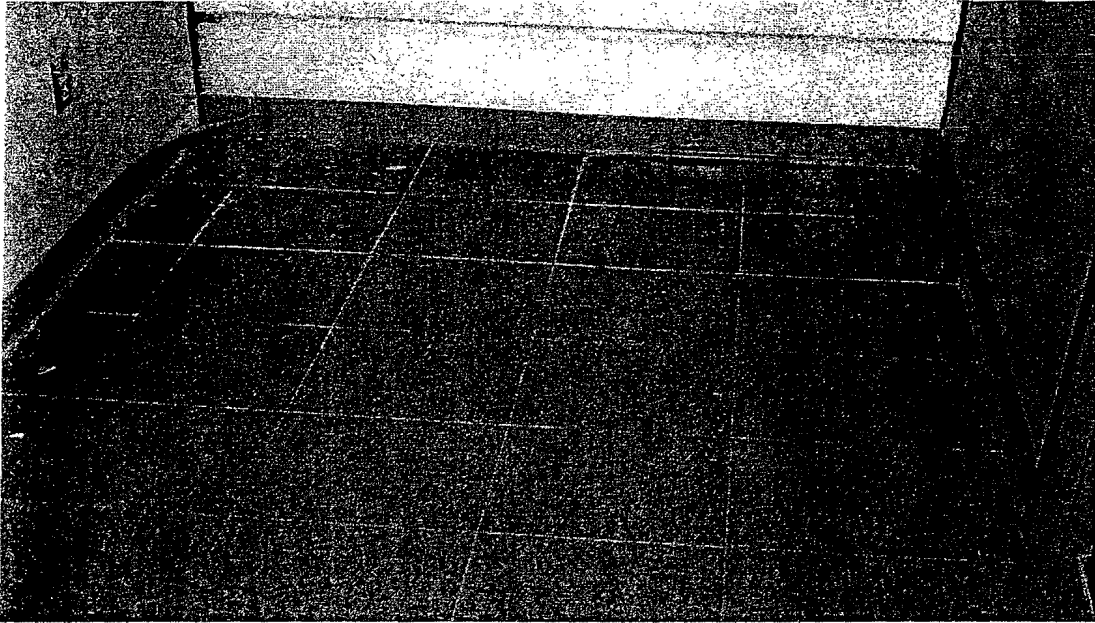

Photo 43: 9TS1, West Wall.

The floor tile at the west end of the corridor had water stains and white residue especially between the tiles as shown above. The base was pulled away for an evaluation but no mold was found. There are visible water stains on the ceiling and wall directly above this area, as shown in Photo 41.

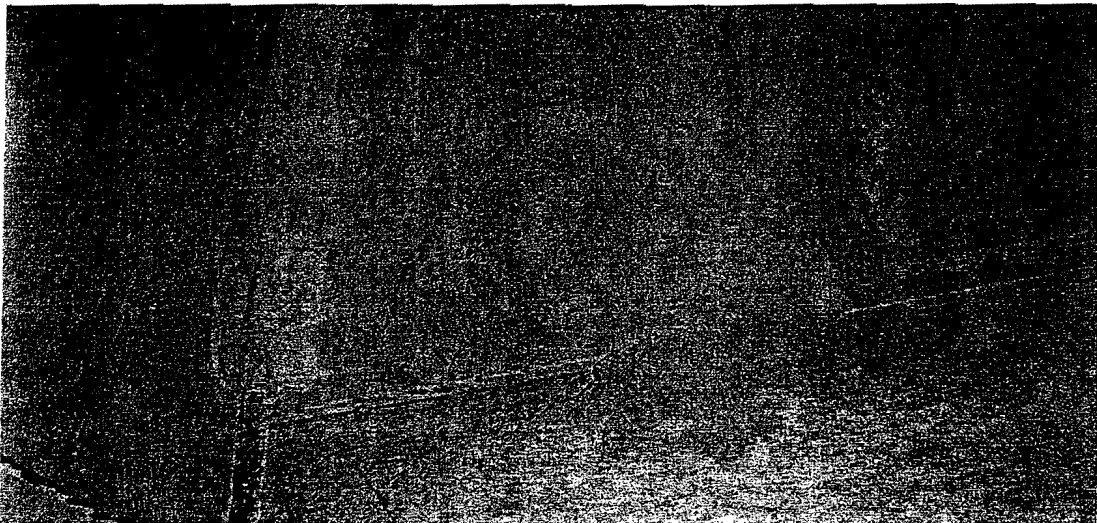

Photo 44: 9TS6, Above Ceiling, East Wall.

A visual inspection conducted by looking through the access panel in the ceiling of stair vestibule 9TS6 showed heavy water stains on the north, east, and west walls above the ceiling. The heaviest stains were near the northeast corner as shown above. No signs of mold were found.

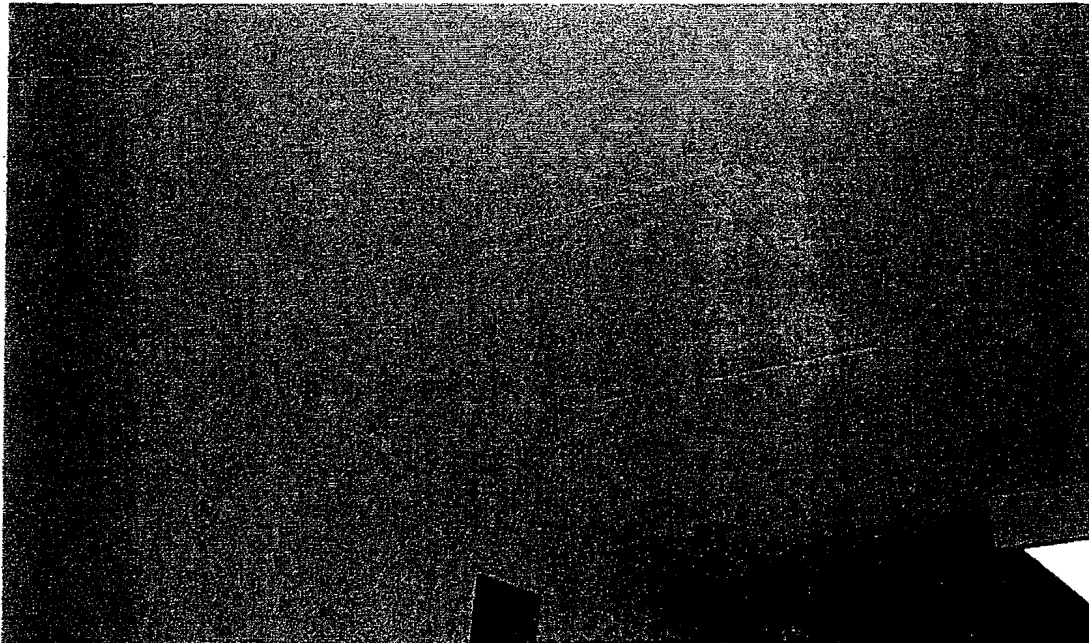

Photo 45: 9TS1, Typical Access Panel.

A typical access panel is shown in Room 9TS1. Several areas above the ceiling and other locations cannot be observed for a thorough mold and moisture evaluation. Access panels should be installed in these locations.



Photo 46: Underside of 9th Floor Deck, West End, Above 8TS1.

A visual inspection conducted by looking through the access panel in the ceiling of corridor 8TS1 revealed discolored and water stained fireproofing on the underside of the 9th floor metal deck as shown above.



Photo 47: South Wall of 8TS1 Above Finished Ceiling.

A suspect mold area was observed on the south wall above the horizontal beam in the unfinished space above the ceiling as shown above. This spot can't be reached from the access panel.



Photo 48: 8TS6 12" by 12" Access Panel Above Ceiling.

Further investigation through the access panel in the ceiling of the stair vestibule 8TS6 revealed a larger area of mold on the west wall of the fire taped gypsum board wall as shown above. This wall intersects the south wall above the corridor ceiling where the mold was found above the ceiling of 8TS1.

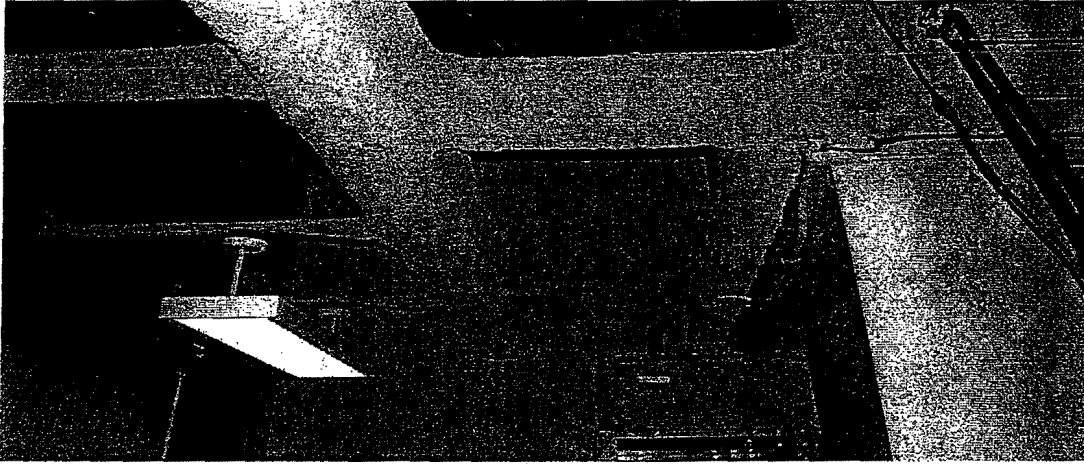

Photo 49: Yellowed Fireproofing, Intermediate Level Beam, 7TS5.

Aspergillus (3704 counts/gram) was detected in 7TS5, in a yellowed fireproofing sample. Similar yellowed fireproofing samples were collected in 7TS5 in the center of the room; in 7TS5 at the ceiling level; in 7TS5 on the metal deck; in 7TS5 on the west side of the elevator shaft; in 7TS5 on the middle of the beam on the north side of the elevator shaft; in 7TS1 above the west access panel; and in 7TS4 on the lower beam, on the west side of the elevator. All contained mold spore concentrations below the limit of detection.

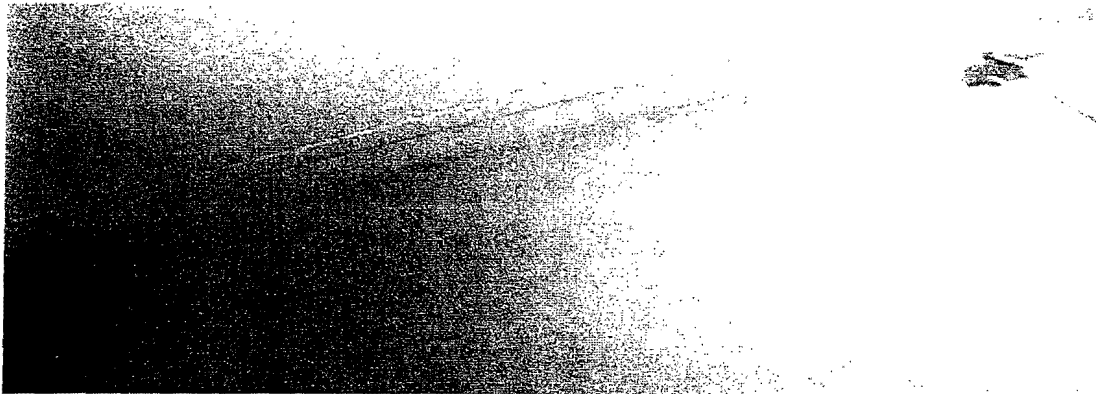

Photo 50: 3TS1, South Wall, Across from Elevator Door.

Alternaria (231 counts/cm²), *Aspergillus* (77 counts/cm²), *Cladosporium* (9240 counts/cm²), *Nigrospora* (31 counts/cm²), *Pithomyces* (62 counts/cm²), *Smuts* (77 counts/cm²) and *Ulocladium* (15 counts/cm²) were detected in 3TS1, on the South wall along the ceiling, directly across from the elevator door. After biocide cleaning, *Cladosporium* (15 counts/cm²) was detected in the same location, however, no mold spore concentration levels were detected after a 2nd biocide cleaning treatment. Surface temperature readings were being taken as shown by the Humilog sensor in the upper right corner.

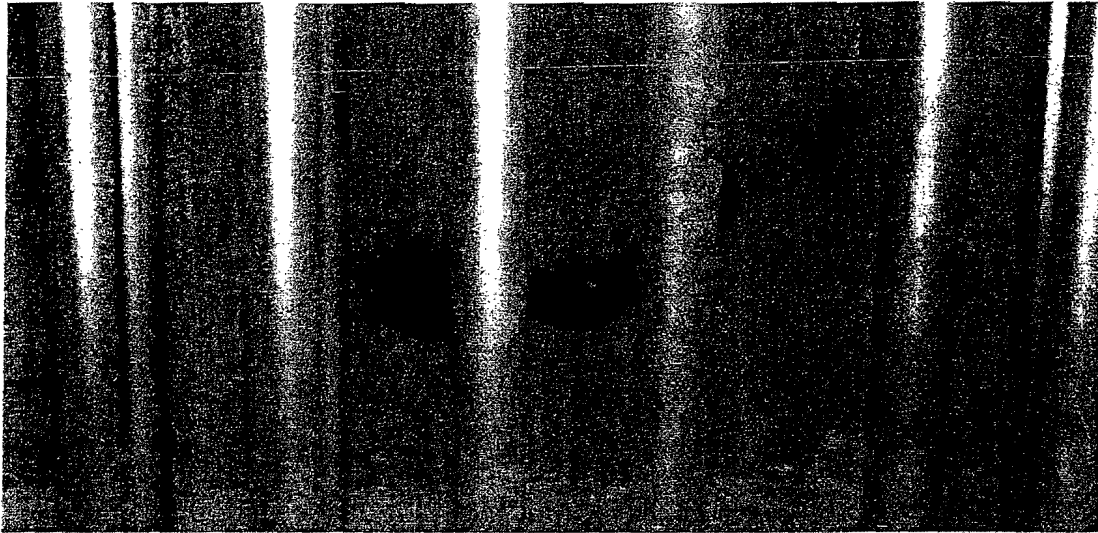

Photo 51: 3TS4, Suspect Stain on Concrete, North Wall.

A tape lift sample collected from the black material shown in Room 3TS4 did not contain mold.

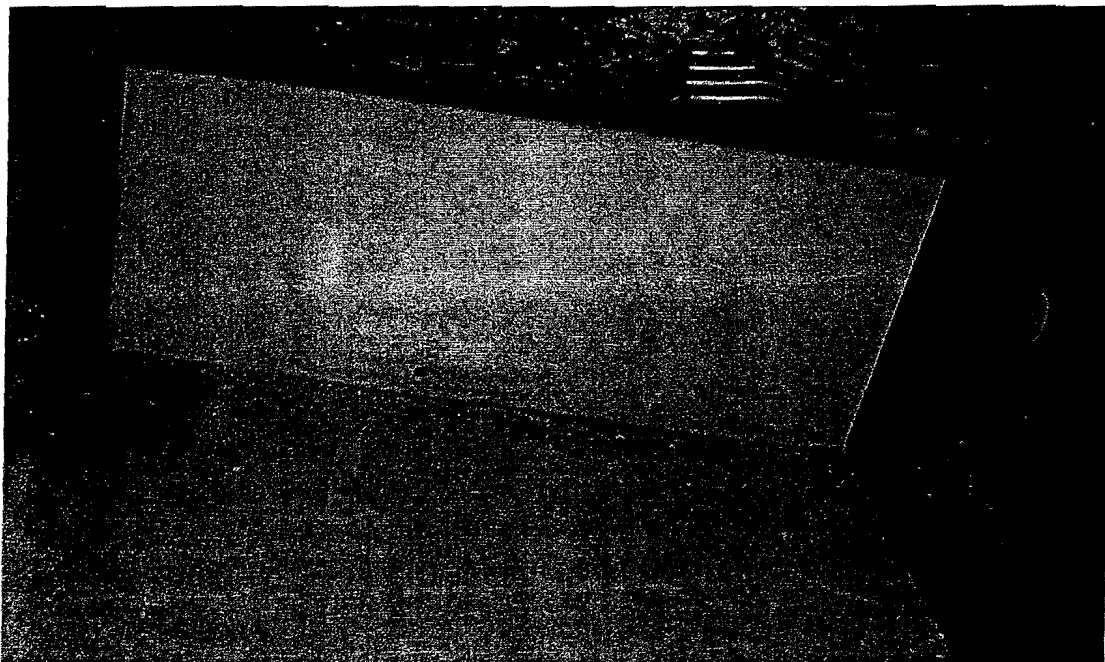

Photo 52: 3TS5, Below Fire Sprinkler Equipment, North of Elevator Shaft.

Vinyl base was pulled at multiple locations in 3TS5 where there were any signs of recurring water damage. The inspection revealed mold throughout the room. The majority of this damage has resulted over time from testing, maintenance, and repair of fire pumps and sprinkler systems.



Photo 53: 3TS5, North Wall.

Mold is shown behind the base on the north wall of Room 3TS5.

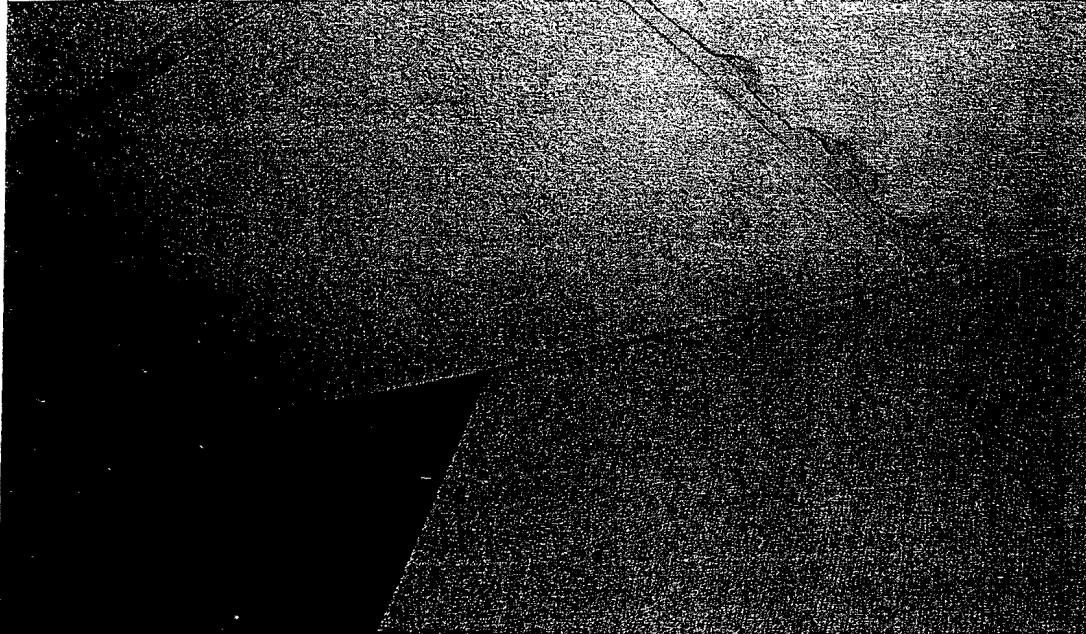

Photo 54: 2TS1, Stained Ceiling Tile.

A water stain was found on the tile adjacent to the wall outside of 2TS5 as the result of condensation from an uninsulated section of cold water return piping as shown above. The pipe is routed through the wall between two metal studs framing the door opening and there was no room to install the pipe insulation used throughout the rest of the facility.



Photo 55: 2TS5, West Side of Elevator Shaft.

Several large water stains were found on the suspended acoustical ceiling in 2TS5 as shown above. Water streaks/stains were visible on the walls forming the elevator shaft and the base below was evaluated, however, no mold was found.

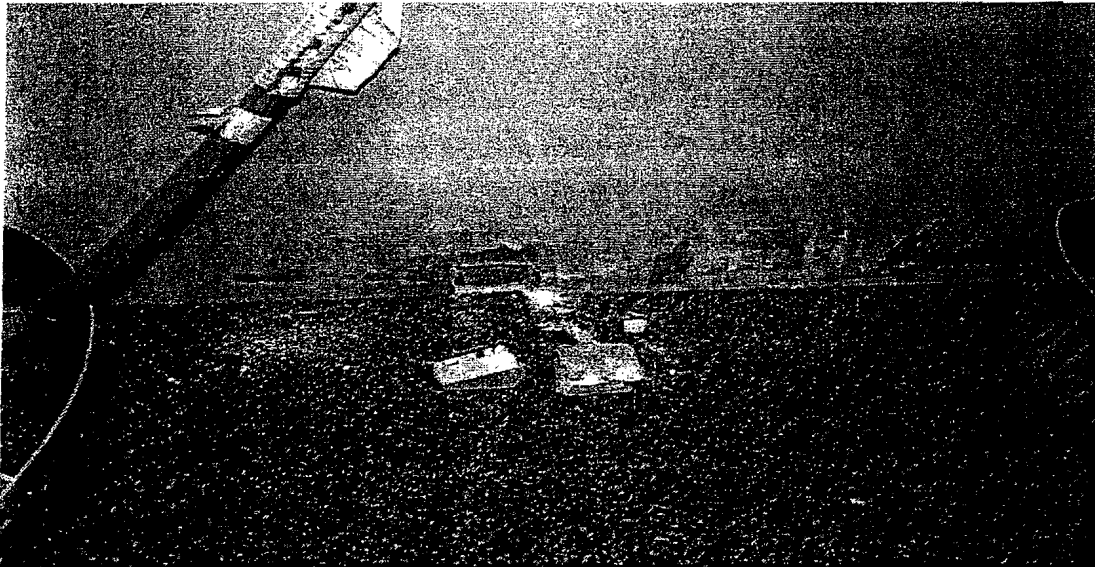

Photo 56: 2TS5, North Wall.

A small amount of mold was found behind the base on the north wall in Room 2TS5. This furred out gypsum board wall was installed adjacent to the precast concrete wall at some point after the ATCT was constructed. The source of water appears to be from old building joint leaks and water leaks from 3TS5.

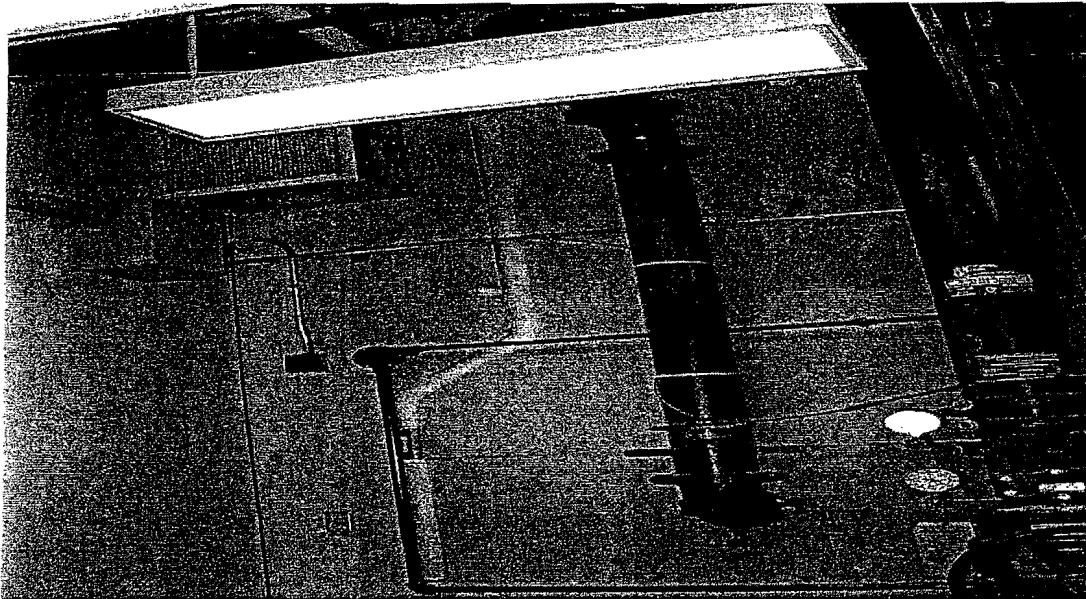

Photo 57: G4, Southwest Corner.

Water stains were visible on the unfinished gypsum board in room G4 adjacent to the outside air duct. It appears that water either leaks around or enters through the 4th floor outside air intake louver and runs down the inside, or exterior of the vertical duct run to the ground floor. This gypsum board serves as a thermal barrier over foam insulation and is not taped, finished, or painted.

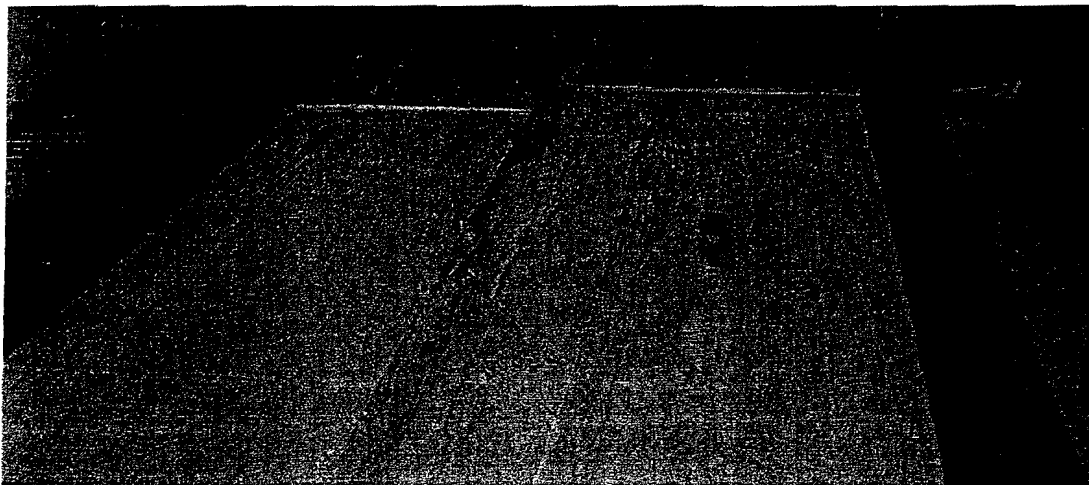

Photo 58: Elevator Shaft.

The elevator shaft was visually inspected on June 19, 2006 by personnel riding on top of the elevator car and making stops at approximately five to ten foot intervals based on conditions observed. The gypsum board shaft liner panels had water streaks or stains at many locations as shown above.



Photo 59: Elevator Shaft.

The only visible mold found on the elevator shaft was in a band approximately two feet high on the north, west, and east sides of the elevator shaft approximately ten feet below the 9th floor slab elevation as shown above.

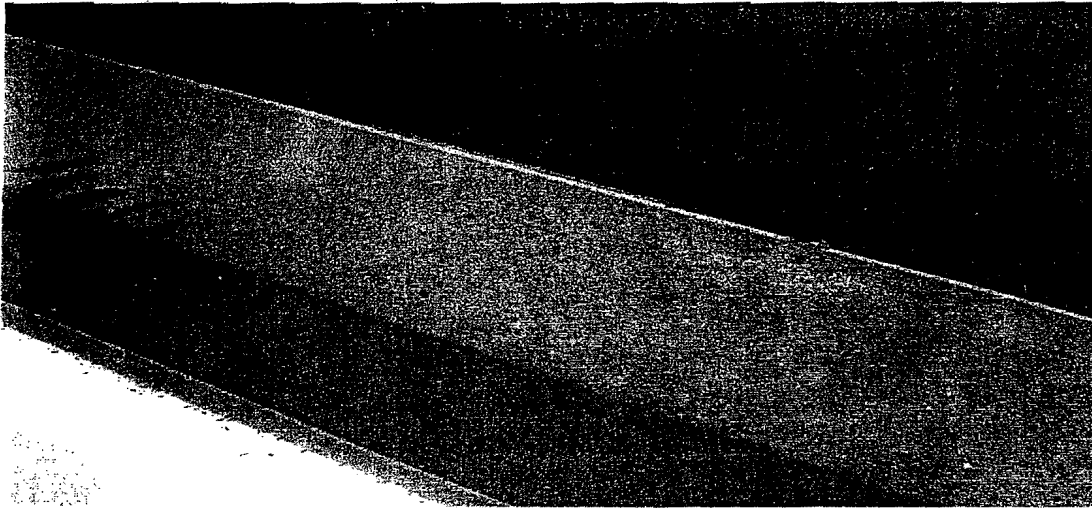
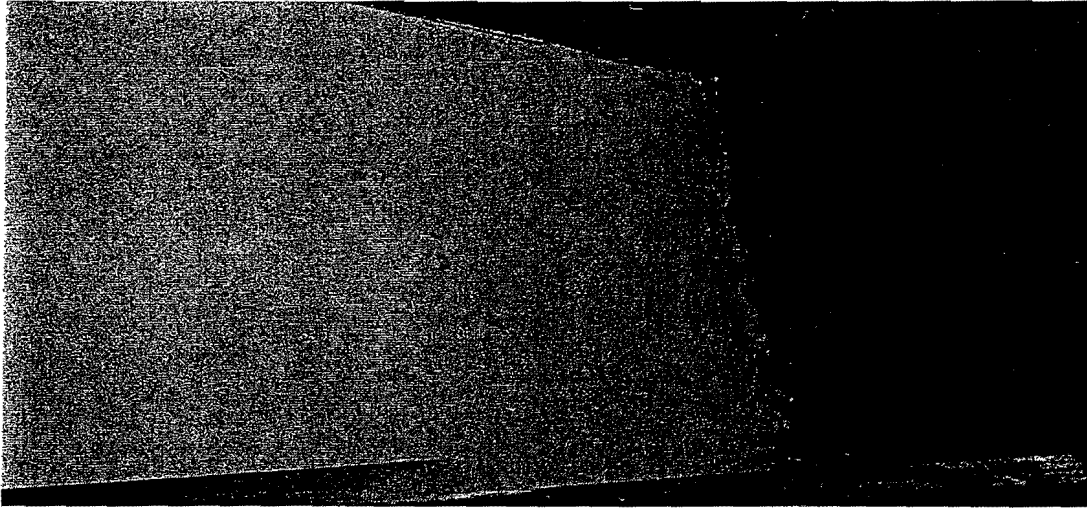

Photo 60: Stairway, Between Junction and Sub Junction Levels, Window Ledge. *Alternaria* (123 counts/cm²), *Ascospores* (31 counts/cm²), *Basidiospores* (31 counts/cm²), *Cladosporium* (108 counts/cm²), *Epicoccum* (62 counts/cm²), *Nigrospora* (15 counts/cm²), and *Smuts* (31 counts/cm²) were detected on the horizontal aluminum ledge of the window. HEPA-vacuuming, followed by biocide cleaning measures, will be required in the areas represented by these sample locations.



**Photo 61: Stairway, Between Junction and Sub Junction Levels,
Gypsum Board Cover.**

Alternaria (262 counts/cm²), *Aspergillus* (108 counts/cm²), *Basidiospores* (108 counts/cm²), *Bipolaris* (46 counts/cm²), *Cladosporium* (1140 counts/cm²), *Epicoccum* (108 counts/cm²), *Nigrospora* (15 counts/cm²), *Smuts* (293 counts/cm²), and *Stachybotrys* (92 counts/cm²) were detected on the gypsum wallboard cover between the stairs. A significant quantity of dust was observed in the area. Dust, when present in substantial amounts, provides a food source for mold. HEPA-vacuuming, followed by biocide cleaning measures, will be required in the area represented by this sample location.

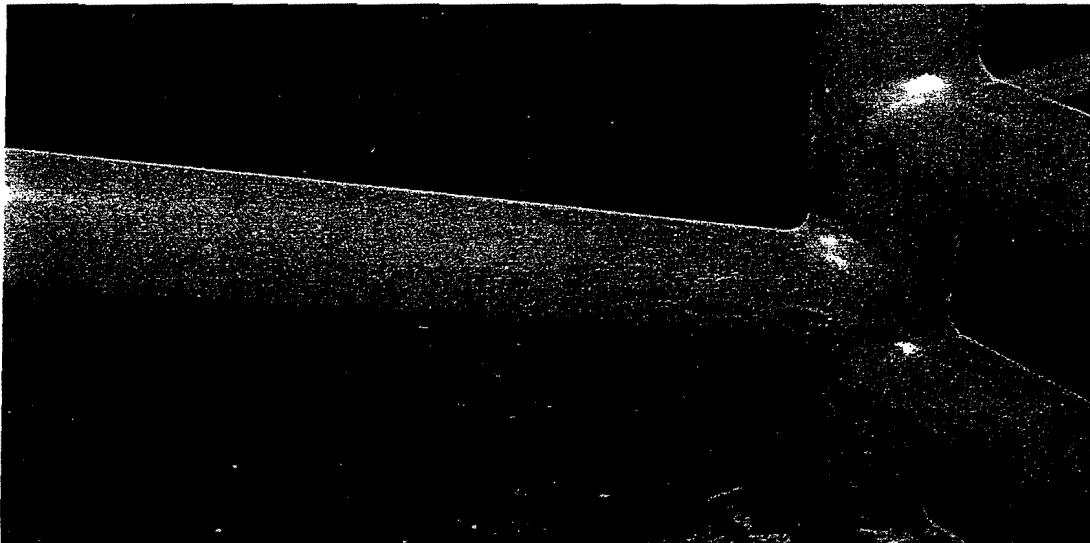

Photo 62: Stairway, Between Junction and Sub Junction Levels, Dusty Handrail.
A dusty handrail is shown above the gypsum board cover in Photo 61.

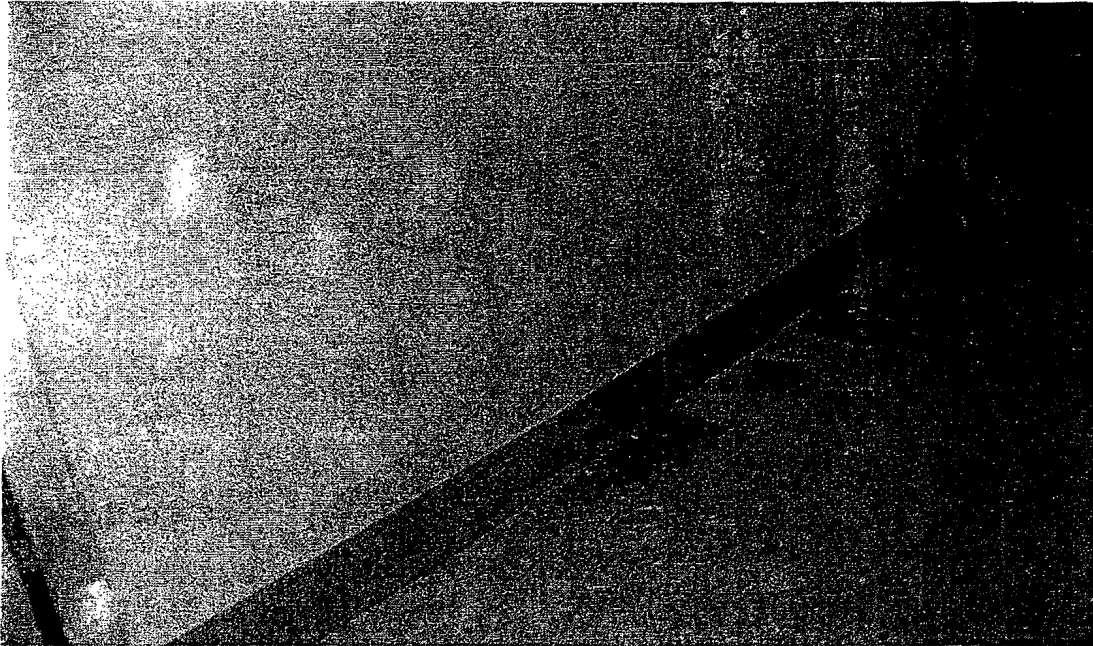

Photo 63: 8TS4, West Wall.

Condensation and frosting are shown on the west wall of Room 8TS4, on January 18, 2007.

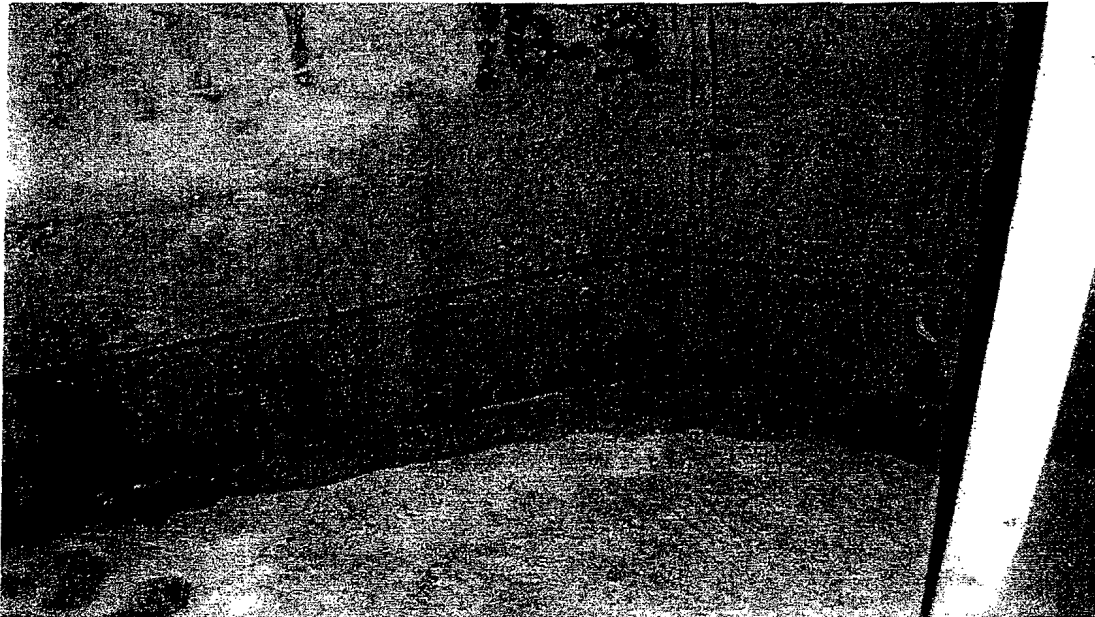

Photo 64: 8TS4, Northeast Wall.

Water and condensation is seen on the northeast wall of Room 8TS4. After a period of warmer outside temperatures, frost has melted and water is seen accumulating on the floor on January 19, 2007.



Photo 65: 10TS5, West Wall.

Standing water is seen along the base of the west wall in Room 10TS5, on January 18, 2007.



Photo 66: 10TS5, North Wall.

After warmer outside temperatures on January 19, 2007, frost on the precast panels begins to melt. Water begins to accumulate on the floor slab.

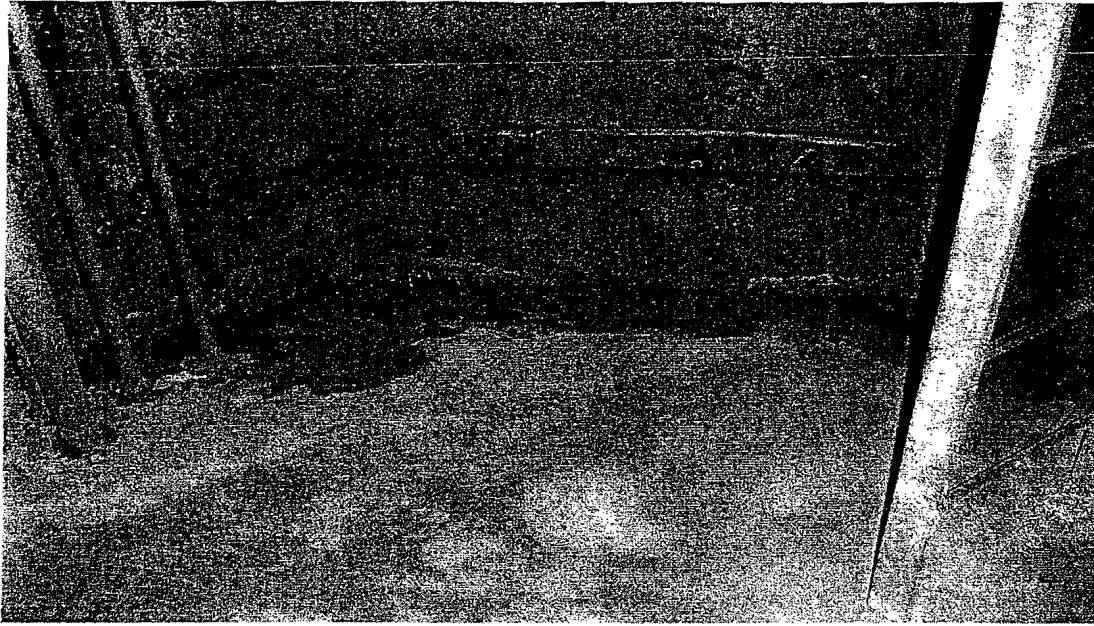

Photo 67: 9TS4, North Wall.

Melting frost and condensation are shown by the north wall of Room 9TS4, on January 18, 2007.



Photo 68: 9TS4, East Wall.

Melting frost and condensation are shown by the north wall of Room 9TS4, on January 19, 2007. Higher outside temperatures caused the surface temperature to rise and more water is seen accumulating on the floor.

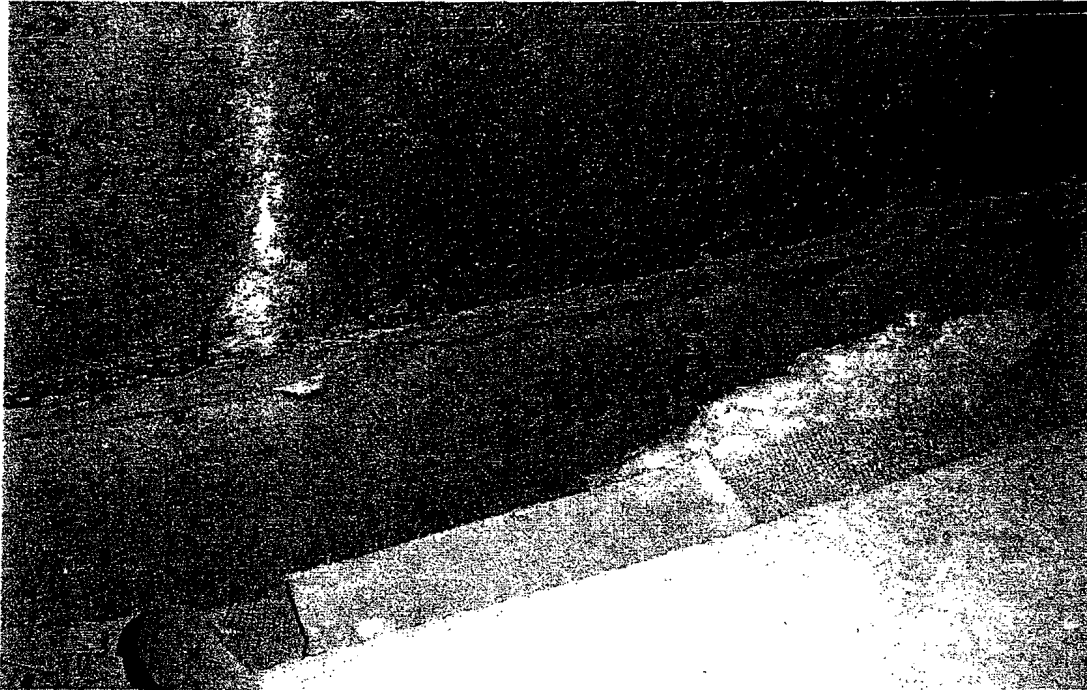

Photo 69: 11th Floor Outer Ring.

Condensation and frosting are shown on the precast walls in the 11th Floor Outer Ring, on January 18, 2007.

26

FAA-ACE472-169

March 29, 2007

**U.S. DEPARTMENT OF TRANSPORTATION
FEDERAL AVIATION ADMINISTRATION
CENTRAL SERVICE AREA**

SPECIFICATION FOR

**Microbiological Remediation and
Restoration**

**Airport Traffic Control Tower
Kansas City International Airport
Kansas City, Missouri**

**MICROBIOLOGICAL REMEDIATION AND RESTORATION
AIRPORT TRAFFIC CONTROL TOWER
KANSAS CITY INTERNATIONAL AIRPORT
KANSAS CITY, MISSOURI**

The following documents and attachments in combination define the scope of work and requirements for the performance of work on this project.

TABLE OF CONTENTS

| | |
|--------------------------------------|----------|
| STATEMENT OF WORK | 12 PAGES |
| APPENDIX: | |
| NEW YORK GUIDELINES | 28 PAGES |
| CLEARANCE PROTOCOL..... | 7 PAGES |
| SUPPLEMENTAL STATEMENT OF WORK | 28 PAGES |
| APPENDIX: | |
| FLOOR PLANS AND NOTES..... | 40 PAGES |
| DRAWINGS | 12 PAGES |

Introduction: The following specification and advisements constitute the working portion of the contract between the Contractor and the Federal Aviation Administration (FAA), an Agency of the United States Government. The Contracting Officer (CO) assigned to this contract shall be the only individual with authority to speak for and contractually bind the FAA. All communications, authorizations, approvals, changes, modifications, etc. involving this contract shall be through the Contracting Officer. Any action not approved by the Contracting Officer shall not bind the FAA.

Contracting Officer's Technical Representative (COTR): The Contracting Officer may assign a COTR to monitor the work being performed on this project and act as a technical point of contact. A letter detailing the COTR's responsibilities and authority will be issued when a COTR is assigned.

STATEMENT OF WORK
MICROBIOLOGICAL REMEDIATION
FOR
FEDERAL AVIATION ADMINISTRATION
KANSAS CITY AIRPORT TRAFFIC CONTROL TOWER (MCI ATCT)
KANSAS CITY, MISSOURI

1.0 WORK SUMMARY. The Contractor is required to furnish all labor, materials, services, equipment, insurance, and perform all the work to remove and dispose of all microbiological contaminated materials (MCM) and microbiological contaminated elements (MCE) described in this scope of work. The Contractor shall be responsible for the cleanup and removal of microbiological contaminated gypsum board, shaft liner, insulation, and pipe insulation in the MCI ATCT Cab Level stairs, Rooms SJ1, 11TS5, 11TS5A, 11TS6, 11th Floor Outer Ring, 10TS4, 10TS5, 8TS1, 8TS5, 8TS6, 4TS3, 3TS3, 3TS5, 2TS5, and G4 in accordance with the guidelines established by the New York City Department of Health entitled *Guidelines on Assessment and Remediation of Fungi in Indoor Environments* (GARFIE) attached and incorporated herein by reference (See Attachment 1). Included in the scope of work is the removal of any MCM between the bottom metal runner/track and the concrete floor; between the top metal runner/track and the structural deck; and between the metal stud and exterior concrete wall. The Contractor shall minimize dust generation and use the methodologies outlined in GARFIE for dust prevention and suppression. Prior to performing microbiological remediation procedures, the Contractor shall seal all critical penetrations and openings to the work area with a minimum of 2-layers of 6-mil polyethylene, and shall be responsible for ensuring adjoining areas are not exposed to the microbial contamination during the remediation. The Contractor shall provide additional cleaning procedures as described herein in the ASDE Level, Cab Level, Junction Level, Subjunction Level, Rooms SJ6 and SJ8, Level 2, Ground Level, Base Building link, elevator shaft, and elevator corridors and stairwells. A complete list of the work required is included in Section 7.0 Work Procedure and the Supplemental Statement of Work. All removals and other cleaning procedures conducted in the ASDE Level, Cab Level and stairs, Junction Level, SJ6, SJ8, 2TS5, 2TS1, 1TS1, and Base Building link shall be conducted at night between the hours of 10:00 PM and 6:00 AM. Cleaning procedures specified for the Subjunction Level shall be conducted between the hours of 10:00 PM and 6:00 AM. Work in the elevator shaft shall be conducted between the hours of 9:00 PM and 6:00 AM. Work in the elevator shaft shall be further restricted to allow for FAA use of the elevator as defined in the Supplemental Statement of Work. Negative air pressure equipment shall be equipped with a HEPA filter and discharged outside of the building whenever possible, otherwise discharged through a second HEPA filter in order to permit recirculation of air inside the building. See the Supplemental Statement of Work (SSOW) for additional work required to perform the remediation work and to restore the facility.

1.1. CONTRACTOR'S RESPONSIBILITY. The Contractor shall perform all work required to give a complete and satisfactory job as required by this statement of work. The Contractor shall be responsible for performing this scope of work in accordance with GARFIE. The Contractor shall perform the work per the schedule and sequence identified in the SSOW (Section 1.1). The Contractor shall be responsible for all debris generated under this contract at the job site and during transport of microbiological containing or contaminated materials to an approved disposal site.

1.1.1 Site Visit. The Contractor is responsible for inspecting the work space and field verifying all quantities for: constructing a negative pressure enclosure for each phase of the work, MCM, MCE removal and disposal, work area physical parameters, access limitations, and Government phasing limitations. The Contractor shall be required to work around existing furniture, fixtures and finishes during the performance of this contract. The site visit shall be scheduled by the Government for interested microbiological remediation Contractors to identify specific work area and phasing requirements.

1.1.2 Property Damage. The Contractor shall take all precautions to avoid damage to Government property or equipment. Any damage to Government property or equipment by the Contractor shall be repaired by the Contractor to its original state or better condition at no additional expense to the Government.

1.1.3 Working Conditions. Portions of the ATCT will be occupied and Government operations will continue on a normal, temporary, or restricted basis for the duration of the project. The Contractor shall take all precautions to ensure that their operations are conducted in a manner that does not interfere with the normal operations of the surrounding facilities and the safety and health of the occupants or the environment. Contractor's personnel will have limited access to the facility.

1.1.4 Cleanup. Upon completion of the work at the site, all staging and debris from the project shall be removed from the site and disposed of properly. The entire area shall be left clean and acceptable to the Government.

1.1.5 Certifications. The Contractor shall be certified by the Indoor Air Quality Association (IAQA), the Institute of Inspection, Cleaning and Restoration Certification (IICRC), the National Duct Cleaning Association (NADCA), or equivalent.

1.2. SCHEDULE. See contract documents for duration of contract and notice to proceed.

1.2.1 Pre-Construction Meeting. The Contractor shall attend a mandatory pre-construction meeting before starting work and the Government will schedule the meeting.

1.3. TEMPORARY FACILITIES AND STAGING AREA. The electrical energy and the water consumed shall be provided by the Government at no cost to the Contractor from existing lines and sources located in the ATCT or Base Building or from services adjacent to the work areas. Contractor's use of utilities shall be coordinated with the Government. Contractor is responsible for ensuring that adequate electrical power and water are available to complete the work. The Contractor will be permitted to use the areas as directed by the Government for staging and storage of materials. The area is restricted to uncontaminated work equipment and supplies. The area shall be left clean and restored to the same condition as when accepted by the Contractor.

1.4. SUBMITTAL REQUIREMENTS. The Contractor will submit the following materials to the Government for review and approval prior to starting work:

- Materials Safety Data Sheets for all chemical products.
- Respiratory Fit Test and Medical Surveillance for employees scheduled for this project.
- Negative Air HEPA Filtration Equipment Specification Sheet.
- HEPA Vacuum Specification Sheet.
- Proposed Phasing Schedule.
- Configuration of typical negative pressure enclosure system and location for each phase.

2.0 MEDICAL REQUIREMENTS. Contractor shall provide medical surveillance and have a written Respiratory Protection program in place as required by 29 CFR 1910.134 for all personnel engaged in the removal and demolition of MCM and MCE. Respirators and filters provided shall be NIOSH approved and provide the appropriate level of protection.

3.0 PROTECTIVE CLOTHING. Contractor shall provide workers and government representatives with sufficient sets of protective full body clothing. Such clothing shall consist of full body coveralls including head covers, foot covers and hand covers. Contractor shall provide additional personal protective safety equipment as required by applicable OSHA safety regulations.

4.0 REMEDIATION AREA. Contractor shall establish a remediation area and restrict the access to the microbiological work areas during work conducted in the ATCT. Contractor shall establish a roped-off perimeter and provide warning barrier tape and signs outside the perimeter of the negative pressure enclosure system. Contractor shall establish a negative pressure enclosure system by sealing all critical penetrations or openings to the work area with a minimum of two layers of six-mil polyethylene. Negative pressure enclosures shall have a minimum of four air exchanges per hour and shall be maintained and recorded with a magnehelic guage or equivalent device under a minimum negative pressure differential of -0.02 inches of water relative to adjacent non-work area space. Negative air pressure equipment shall be equipped with a HEPA filter and exhaust shall be discharged outside the building, a minimum of 25 feet from building access points and building make-up air sources, or wherever necessary, negative air pressure equipment shall be equipped with a

HEPA filter and exhaust shall be discharged through a second HEPA filter in order to permit recirculation of air inside the building. Personnel shall wear and utilize protective clothing and equipment in the remediation area as specified herein.

5.0 DECONTAMINATION AREA. Contractor shall establish a decontamination unit for passage to and from the work area during remediation operations in order to minimize the leakage of mold-contaminated dust to the outside. This unit shall consist of a minimum of two chambers, including a clean room and equipment room separated by airlocks. The airlocks shall be formed by overlapping three sheets of 6-mil polyethylene sheeting at the exit of one room and three sheets at the entrance to the next room, with three feet of space between the barriers. Airlocks shall be constructed to effectively maintain negative pressure while not inhibiting worker egress in an emergency situation.

6.0 WORKER PROTECTION PROCEDURE.

- 6.1. Each worker and authorized visitor shall, upon entering the job site, put on appropriate respirator and clean protective clothing, before entering the work area.
- 6.2. Each worker and authorized visitor shall remove gross contamination from clothing by HEPA vacuuming, prior to leaving the remediation work area. After decontamination of protective clothing, while still wearing the respirator, remove protective clothing and dispose as microbiological waste, as appropriate, in a drum or 2-layers of 6-mil polyethylene disposal bags.
- 6.3. Workers shall not eat, drink, smoke, or chew gum or tobacco at the work site. Workers shall be fully protected with respirators and protective clothing immediately prior to the first disturbance of MCM or MCE and until final cleanup is completed.

7.0 WORK PROCEDURE.

- 7.1. Moisture damage restoration and mold remediation shall be conducted as necessary and as described in the Cab Level stairs, Rooms SJ1, 11TS5, 11TS5A, 11TS6, 11th Floor Outer Ring, 10TS4, 10TS5, 8TS1, 8TS5, 8TS6, 4TS3, 3TS3, 3TS5, 2TS5, and G4.
- 7.2. Prior to performing microbiological remediation procedures, the Contractor shall seal all critical penetrations and openings to the work area. Establish phasing schedule with Government for each days work activity. Contractor shall HEPA-vacuum and/or wet wipe with a detergent solution all non-porous furniture and fixtures. Contractor will remove any furnishings from the remediation area, after it has been pre-cleaned. Upon completion, the Contractor will return the furnishings to the original location. If necessary, furnishings can be pre-cleaned and wrapped with 2 layers of 6-mil polyethylene and allowed to remain in the remediation area. Electrical equipment that poses an electrical hazard shall be HEPA vacuumed only.
- 7.3. Maintain a minimum of four air exchanges per hour within the remediation work area and a minimum negative pressure differential of -0.02 inches of water, continuously recorded by use of a magnehelic guage or equivalent device.

Negative air pressure equipment shall be equipped with a HEPA filter and discharged outside of the building whenever possible, otherwise discharged through a second HEPA filter in order to permit recirculation of air inside the building. Contractor will secure entrance into the regulated area at the conclusion of each workday.

- 7.4. The walls undergoing remediation are fire rated partitions and have multiple layers of fire resistant gypsum board on each face unless otherwise indicated. See floor plans and the sheet "PARTITION TYPES" in the appendix of the SSOW for details of the wall construction in each area. Removal limits shall coincide with existing metal studs at or beyond the limits identified below. Joints between gypsum board on the surface and concealed layer shall be staggered horizontally and vertically, unless limits are the entire wall and less than the length of gypsum board utilized. The shaft liner panels are 1" thick fire resistant gypsum board. Demolition work shall be conducted utilizing methods to minimize noise and the spread of dust, such as the use of HEPA vacuums at the point of cutting and/or tools with shrouds or boots connected to a HEPA vacuum. See SSOW for additional requirements. The locations and approximate quantities for gypsum board remediation are listed below:

Gypsum board and insulation totaling approximately four square feet will be removed from the Cab Level stairs at the walkway door. This area includes the portion west of the door, from frame to corner bead, 12" wide to a height of 18" and the portion east of the door, from frame to the north, a minimum of 2' wide to a height of 18".

Gypsum board totaling approximately twenty square feet will be removed from the Cab stairs. This area includes the water stained portion on the sloped ceiling section directly beneath the sink, 38" wide to a height of 6'2".

Gypsum board, shaft liner, and insulation totaling approximately 611 square feet will be removed from the Subjunction Level Equipment Room SJ1. On the west wall, this area begins at the southwest corner of the room extending northward, 15' to a height of 12' (surface layer), 13' wide to a height of 12' (concealed layer), and approximately 50% of the shaft liner on the entire west and northwest walls (an area equal to 20' wide to a height of 12'). Opening of the west wall will allow for a closer evaluation of the concealed layer and shaft liner behind the perimeter walls. The Contractor shall install temporary walk boards between the precast panels and perimeter walls on the east, north, and west sides to allow inspection of the shaft liner. See Supplemental Statement of Work for additional details. Subsequent necessary removal limits shall be determined accordingly. In the absence of any contamination, the surfaces behind the cove base on the north wall shall be wet wiped and scrubbed with a concentrated Sporidicin disinfectant solution. On the south wall, this area begins on the west side of the door of Mechanical Room SJ7 to the southwest corner of the room, 10' wide to a height of approximately 3' to the bottom of the door of Room SJ8 (surface layer) and 2' wide to a height of 2.5' (concealed layer). Contractor shall

HEPA-vacuum and/or wet wipe with a concentrated Sporidicin disinfectant solution all surfaces below raised flooring, including concrete floor, raised floor system, cables, conduit, etc. upon completion of remediation.

Gypsum board and insulation totaling approximately 126 square feet will be removed from 11TS5 and 11TS5A. In 11TS5, on the west wall, this area includes the southwest corner of the room, 3.5' wide to a height of 3' (surface layer) and 2.25' wide to a height of 30" (concealed layer). On the south wall, this area includes the southeast corner of the room to the door, 3.5' wide to a height of 42". On the east wall, this area includes the southeast corner of the room to the door to 11TS5A, 10.5' wide to a height of 4' (surface layer) and 10.5' wide to a height of 42" (concealed layer). In 11TS5A, on the west wall, this area includes the portion between the door to 11TS5 and the northwest corner of the elevator shaft, 30" wide to a height of 4' (surface layer) and 30" wide to a height of 42" (concealed layer).

Gypsum board, and insulation totaling approximately 18 square feet will be removed from 11TS6. On the west wall, this area begins in the southwest corner extending northward, 4' wide to a height of 18" (surface layer) and 32" wide to a height of 12" (concealed layer). On the south wall, this area begins in the southwest corner extending to the east wall, 3'7" wide to a height of 18" (surface layer) and 3'7" wide to a height of 12" (concealed layer).

Gypsum board, debris, and fire safing insulation will be removed from the 11th Floor Outer Ring. The Contractor shall visually estimate the approximate quantity. This area includes the void between the edge of the floor slab, precast exterior walls, and perimeter fire rated gypsum board walls.

Gypsum board, shaft liner, and insulation totaling approximately 415 square feet will be removed from 10TS5. On the north wall, this area extends from the east wall (between 10TS5 and 10TS4) to the west column enclosure, 18.2' wide to a height of 6' (surface layer), 18.2' wide to a height of 5' (concealed layer), and includes up to 5 pieces of shaft liner, each 2' wide to a height of 5'. On the northwest column enclosure, this area includes the east side, 3'6" wide to a height of 6' (surface layer) and 3'6" wide to a height of 5' (concealed layer). On the south wall, this area includes the portion north of the elevator shaft from the east wall to the northwest corner, 9'8" wide to a height of 4' (surface layer) and 9'8" wide to a height of 2' (concealed layer). On the east walls, these areas include the entire portion west of the elevator shaft, 7'10" to a height of 4' (surface layer) and 7'10" wide to a height of 2' (concealed layer); and the entire portion between 10TS5 and 10TS4, 7'3" wide to a height of 2' (surface layer) and 7'3" wide to a height of 1' (concealed layer).

Gypsum board and insulation totaling approximately 33 square feet will be removed from 10TS4. On the south wall, this area includes the portion between the door and the east wall, 3' wide to a height of 4' (surface layer) and 3' wide to a height of 2' (concealed layer). On the east wall, this area includes the portion from

the column enclosure in the corner southward, 4'10" wide to a height of 2' (surface layer) and 3'6" wide to a height of 18" (concealed layer).

Gypsum board totaling approximately 39 square feet will be removed from the area above the ceiling of 8TS1. See Supplemental Statement of Work for an access door to be installed for access to this area. On the south wall, the area includes the stained portion above the horizontal beam in the unfinished space above the ceiling, 6' wide to a height of 4' (surface layer) and 5' wide to a height of 3' (concealed layer).

Gypsum board totaling approximately 31 square feet will be removed from the area above the ceiling of 8TS6. On the west wall, this area includes the stained portion, which intersects the south wall of 8TS1 in the unfinished space above the ceiling, 4' wide to a height of 5' (surface layer) and 32" wide to a height of 4' (concealed layer). Remove additional gypsum board on the north wall to provide space to pass materials through the wall into the space above the ceiling of 8TS1.

Gypsum board totaling approximately 11 square feet will be removed from 4TS3. On the north wall, this area includes the portion between the door and the east precast wall, 34" wide to a height of 2' (surface layer) and 34" wide to a height of 18" (concealed layer).

Gypsum board totaling approximately 77 square feet will be removed from 3TS3. On the east wall, this area includes the entire portion, 9'7" wide to a height of 8'.

Gypsum board totaling approximately 213 square feet will be removed from 3TS5. On the north wall, this area includes the entire portion, 19' wide to a height of 3'. On the northwest wall, this area includes the entire portion, 3'4" wide to a height of 3'. On the west wall, this area includes the entire portion, 12'1" wide to a height of 3'. On the east walls, these areas include both portions, 14'4" wide to a height of 3' (surface layer) and 14'4" wide to a height of 2' (concealed layer). On the south wall adjacent to corridor 3TS1, these areas include the portion on both sides of the door, 8' wide to a height of 3'9". On the south wall adjacent to the elevator shaft, gypsum board removal will occur with fire pump panels left in place. This area includes a portion 10' wide to a height of 6" (surface layer) and 10' wide to a height of 4" (concealed layer). Remove additional gypsum board if contaminated on the east and west ends of fixed equipment to a height of 36" (surface layer) and to a height of 30" (concealed layer).

Gypsum board totaling approximately 13 square feet will be removed from 2TS5. On the north wall, this area extends from the northeast corner, 6.5' wide to a height of 2'.

Water stained gypsum board totaling approximately 14 square feet will be removed from G4. On the west wall, this area includes the portion of gypsum board covering rigid insulation beneath the outside air duct.

- 7.5. In the Cab Level stairs at the walkway door, Room SJ1 (west and south walls), 11TS5 (south and east walls), 11TS5A, 11th Floor Outer Ring, 10TS5, and 3TS5, a containment and negative pressure enclosure system shall be established as described in Section 4.0 Remediation Area. In Room SJ1 (west and south walls), 11TS5 (south and east walls), 11TS5A, 11th Floor Outer Ring, 10TS5, and 3TS5, a decontamination unit shall be established as described in Section 5.0 Decontamination.
- 7.6. In Rooms 11TS5 (west wall), 11TS6 (south and west walls), 10TS4 (south and east walls), 8TS1, 8TS6, 4TS3, 3TS3, and 2TS5, the work area shall be unoccupied, however, a containment and negative pressure enclosure system are not required. Prior to remediation, the work area shall be misted. Upon completion, the work area shall be HEPA vacuumed and then wet wiped with a detergent solution.
- 7.7. In the 11th Floor Outer Ring, the negative air machine and critical barrier shall be located in the corridor adjacent to the access panel. Prior to remediation, the work area shall be misted. Upon completion, the void shall be HEPA vacuumed. The ledge, created by the protruding sloped precast panel, and the walls, to a height of 4' above the ledge, shall be HEPA vacuumed and wet wiped with a detergent solution.
- 7.8. In Room G4, the work area shall be unoccupied, however, a containment and negative pressure enclosure system are not required. Prior to remediation, the work area shall be misted. Upon completion, the work area shall be HEPA vacuumed and then wet wiped with a detergent solution.
- 7.9. In the Cab Level stairs, the entire water stained area below the contaminated gypsum board shall first be covered and sealed with two layers of 6-mil polyethylene sheeting to contain dust and debris. From under the sink, the visibly mold-contaminated area shall then be misted, sealed with sheeting, and be cut out and removed, followed by HEPA vacuuming and wet wiping with a detergent solution. Upon completion, the remainder of the gypsum board on the sloped ceiling section shall be removed.
- 7.10. In the elevator shaft, the mold-contaminated area totaling less than 10 square feet shall be pre-cleaned by wet wiping with a detergent solution. This area includes a band, up to 2' in height, on the north, west, and south walls, approximately ten feet below the 9th Floor slab elevation. After being allowed to dry, the entire shaft shall be wet wiped again with a detergent solution. The Contractor shall be responsible for contracting with the existing elevator maintenance contractor regarding procedures for use of the elevator car to perform the work required in the elevator shaft required by this Statement of Work. See SSOW for requirements.

In Room 8TS5, gypsum board totaling approximately 26 square feet will be removed. This area includes the portion on the south wall beginning at the northwest corner and extending to the east, 6' wide to a height of 3' (surface layer) and 4' wide to a height of 2' (concealed layer). The opening shall be centered

approximately 13'6" above floor finish to coincide with the location of the mold found on the shaft liner panel in the elevator shaft.

- 7.11. In Rooms SJ6 and SJ8, floors shall be HEPA vacuumed and then wet wiped with a detergent solution. Metal walls shall be wet wiped with a detergent solution. Prior to vacuuming floor in Room SJ8, the air intake opening shall be sealed with 2 layers of 6-mil polyethylene sheeting.
- 7.12. In the Cab Level, Junction Level, Subjunction Level, Level 2, Ground Level, the Base Building link and stairwells, all supply air diffusers or registers, return air grilles, and exhaust grilles shall be HEPA vacuumed and then wet wiped with a detergent solution. All ceiling mounted speaker covers shall be HEPA vacuumed.
- 7.13. In the Subjunction Level Room SJ1, the gypsum board enclosing the steel bracing in the northwest and northeast corners shall be HEPA vacuumed and then wet wiped with a detergent solution.
- 7.14. In the stairwells, all stair stringers, window ledges, window frames, gypsum board caps, and walls where visible dust is present shall be HEPA vacuumed and then wet wiped with a detergent solution. All remaining surfaces shall be wet wiped with a detergent solution.
- 7.15. In the elevator corridors, recessed areas around the elevator door shall be HEPA vacuumed and then wet wiped with a detergent solution. This area includes the TS1 Rooms between Level 3 and the Junction Level. All remaining surfaces shall be wet wiped with a detergent solution.
- 7.16. In the ASDE Penthouse and ASDE Vestibule, all insulated metal panel (IMP) walls shall wet wiped with a detergent solution or equivalent to clean and remove the water marks.
- 7.17. In Rooms CA1 (approximately 9 linear feet), above the ceiling of SJ1 (approximately 4 linear feet), 11th Floor Outer Ring (approximately 11 linear feet), 10TS3 (approximately 3 linear feet), 9TS3 (approximately 3 linear feet), 4TS3 (approximately 5 linear feet), and 3TS5 (approximately 10 linear feet), the water stained pipe insulation shall be removed and replaced.
- 7.18. Between Room 2TS5 and the corridor, approximately 1 linear foot of uninsulated chilled water return piping passing between two metal studs adjacent to the door, shall be insulated. Trim flange of metal stud to install insulation and brace cut studs to adjacent uncut studs with a section of metal stud or runner.
- 7.19. Place MCM and MCE in a fiber/cardboard type drum or 2-layers of 6-mil polyethylene disposal bags with contents clearly labeled. At completion of each phase, notify the Government of completion so that Government can perform a visual inspection of the work area. Allow negative pressure system to operate a minimum of two hours after the last clean-up effort.
- 7.20. Upon approval of Government, remove barriers and disassemble regulated work area. Additional cleaning required in the work area because of the Government

inspection, shall be performed by Contractor, at no additional cost to the Government.

- 8.0 AIR MONITORING AND INSPECTION.** The Government retained industrial hygienist will determine any requirement for air monitoring, both during the remediation process and/or upon completion of the remediation process. Such area sampling will be conducted using Zefon filters and a high volume sampling pump. Procedural modifications to the decontamination procedures may be necessary at the discretion of the Government-retained industrial hygienist. The Government has the right to inspect the remediation work at times to be determined by the Government, but, at a minimum, once upon completed removal of contaminated materials, but before new drywall is installed.
- 9.0 FINAL CLEARANCE.** Acceptance of work will be dependant upon visual inspection and/or clearance monitoring. The Contractor shall notify the Government when the microbiological removal is completed for each phase and the Government-retained industrial hygienist shall perform a thorough visual inspection of the phase within 24-hours. After Rooms SJ1, 11TS5, 10TS5, and 3TS5 have passed the visual inspection, clearance air sampling shall be performed. Clearance criteria shall be dependant upon the requirements stipulated in the MCI ATCT Mold Remediation Clearance Protocol. All remaining rooms shall be cleared by visual inspection.
- 10.0 DISPOSAL.** All microbiological waste shall be disposed of at a municipal sanitary landfill. Waste bags shall not be overloaded and shall be securely sealed and stored in the designated area until disposal. Label bags, disposal containers, and truck during loading and unloading, in accordance with Federal, State and Local regulations. Contractor is responsible for removal of all materials from the Government's property.

ATTACHMENT 1

**Guidelines on Assessment and Remediation of
Fungi in Indoor Environments**



New York City Department of Health & Mental
Hygiene
Bureau of Environmental & Occupational Disease

Epidemiology

Guidelines on Assessment and Remediation of Fungi in Indoor Environments

- Executive Summary
- Introduction
- Health Issues
- Environmental Assessment
- Remediation
- Hazard Communication
- Conclusion
- Notes and References
- Acknowledgments

Executive Summary

On May 7, 1993, the New York City Department of Health (DOH), the New York City Human Resources Administration (HRA), and the Mt. Sinai Occupational Health Clinic convened an expert panel on *Stachybotrys atra* in Indoor Environments. The purpose of the panel was to develop policies for medical and environmental evaluation and intervention to address *Stachybotrys atra* (now known as *Stachybotrys chartarum* (SC)) contamination. The original guidelines were developed because of mold growth problems in several New York City buildings in the early 1990's. This document revises and expands the original guidelines to include all fungi

(mold). It is based both on a review of the literature regarding fungi and on comments obtained by a review panel consisting of experts in the fields of microbiology and health sciences. It is intended for use by building engineers and management, but is available for general distribution to anyone concerned about fungal contamination, such as environmental consultants, health professionals, or the general public.

We are expanding the guidelines to be inclusive of all fungi for several reasons:

- Many fungi (e.g., species of *Aspergillus*, *Penicillium*, *Fusarium*, *Trichoderma*, and *Memnoniella*) in addition to SC can produce potent mycotoxins, some of which are identical to compounds produced by SC. Mycotoxins are fungal metabolites that have been identified as toxic agents. For this reason, SC cannot be treated as uniquely toxic in indoor environments.
- People performing renovations/cleaning of widespread fungal contamination may be at risk for developing Organic Dust Toxic Syndrome (ODTS) or Hypersensitivity Pneumonitis (HP). ODTS may occur after a *single heavy* exposure to dust contaminated with fungi and produces flu-like symptoms. It differs from HP in that it is not an immune-mediated disease and does not require repeated exposures to the same causative agent. A variety of biological agents may cause ODTS including common species of fungi. HP may occur after repeated exposures to an allergen and can result in permanent lung damage.
- Fungi can cause allergic reactions. The most common symptoms are runny nose, eye irritation, cough, congestion, and aggravation of asthma.

Fungi are present almost everywhere in indoor and outdoor environments. The most common symptoms of fungal exposure are runny nose, eye irritation, cough, congestion, and aggravation of asthma. Although there is evidence documenting severe health

effects of fungi in humans, most of this evidence is derived from ingestion of contaminated foods (i.e., grain and peanut products) or occupational exposures in agricultural settings where inhalation exposures were very high. With the possible exception of remediation to very heavily contaminated indoor environments, such high-level exposures are not expected to occur while performing remedial work.

There have been reports linking health effects in office workers to offices contaminated with moldy surfaces and in residents of homes contaminated with fungal growth. Symptoms, such as fatigue, respiratory ailments, and eye irritation were typically observed in these cases. Some studies have suggested an association between SC and pulmonary hemorrhage/hemosiderosis in infants, generally those less than six months old. Pulmonary hemosiderosis is an uncommon condition that results from bleeding in the lungs. The cause of this condition is unknown, but may result from a combination of environmental contaminants and conditions (e.g., smoking, fungal contaminants and other bioaerosols, and water-damaged homes), and currently its association with SC is unproven.

The focus of this guidance document addresses mold contamination of building components (walls, ventilation systems, support beams, etc.) that are chronically moist or water damaged. Occupants should address common household sources of mold, such as mold found in bathroom tubs or between tiles with household cleaners. Moldy food (e.g., breads, fruits, etc.) should be discarded.

Building materials supporting fungal growth must be remediated *as rapidly as possible* in order to ensure a healthy environment. Repair of the defects that led to water accumulation (or elevated humidity) should be conducted in conjunction with or prior to fungal remediation. Specific methods of assessing and remediating fungal contamination should be based on the extent of visible contamination and underlying damage. The simplest and most expedient remediation that is reasonable, and properly and safely removes fungal contamination, should be used. Remediation and assessment methods are described in this document.

The use of respiratory protection, gloves, and eye protection is recommended. Extensive contamination, particularly if heating, ventilating, air conditioning (HVAC) systems or large occupied spaces are involved, should be assessed by an experienced health and safety professional and remediated by personnel with training and experience handling environmentally contaminated materials. Lesser areas of contamination can usually be assessed and remediated by building maintenance personnel. In order to prevent contamination from recurring, underlying defects causing moisture buildup and water damage must be addressed. Effective communication with building occupants is an essential component of all remedial efforts.

Fungi in buildings may cause or exacerbate symptoms of allergies (such as wheezing, chest tightness, shortness of breath, nasal congestion, and eye irritation), especially in persons who have a history of allergic diseases (such as asthma and rhinitis). Individuals with persistent health problems that appear to be related to fungi or other bioaerosol exposure should see their physicians for a referral to practitioners who are trained in occupational/environmental medicine or related specialties and are knowledgeable about these types of exposures. Decisions about removing individuals from an affected area must be based on the results of such medical evaluation, and be made on a case-by-case basis. Except in cases of widespread fungal contamination that are linked to illnesses throughout a building, building-wide evacuation is not indicated.

In summary, prompt remediation of contaminated material and infrastructure repair is the primary response to fungal contamination in buildings. Emphasis should be placed on preventing contamination through proper building and HVAC system maintenance and prompt repair of water damage.

This document is not a legal mandate and should be used as a guideline. Currently there are no United States Federal, New York State, or New York City regulations for evaluating potential health effects of fungal contamination and remediation. These guidelines are subject to change as more information regarding fungal contaminants becomes available.

[top of page](#)

Introduction

On May 7, 1993, the New York City Department of Health (DOH), the New York City Human Resources Administration (HRA), and the Mt. Sinai Occupational Health Clinic convened an expert panel on *Stachybotrys atra* in Indoor Environments. The purpose of the panel was to develop policies for medical and environmental evaluation and intervention to address *Stachybotrys atra* (now known as *Stachybotrys chartarum* (SC)) contamination. The original guidelines were developed because of mold growth problems in several New York City buildings in the early 1990's. This document revises and expands the original guidelines to include all fungi (mold). It is based both on a review of the literature regarding fungi and on comments obtained by a review panel consisting of experts in the fields of microbiology and health sciences. It is intended for use by building engineers and management, but is available for general distribution to anyone concerned about fungal contamination, such as environmental consultants, health professionals, or the general public.

This document contains a discussion of potential health effects; medical evaluations; environmental assessments; protocols for remediation; and a discussion of risk communication strategy. The guidelines are divided into four sections:

1. Health Issues;
2. Environmental Assessment;
3. Remediation; and
4. Hazard Communication.

We are expanding the guidelines to be inclusive of all fungi for several reasons:

- Many fungi (e.g., species of *Aspergillus*, *Penicillium*, *Fusarium*, *Trichoderma*, and *Memnoniella*) in addition to SC can produce potent mycotoxins, some of which are identical to compounds produced by SC.^{1, 2, 3, 4} Mycotoxins are fungal metabolites that

have been identified as toxic agents. For this reason, SC cannot be treated as uniquely toxic in indoor environments.

- People performing renovations/cleaning of widespread fungal contamination may be at risk for developing Organic Dust Toxic Syndrome (ODTS) or Hypersensitivity Pneumonitis (HP). ODTS may occur after a *single heavy* exposure to dust contaminated with fungi and produces flu-like symptoms. It differs from HP in that it is not an immune-mediated disease and does not require repeated exposures to the same causative agent. A variety of biological agents may cause ODTS including common species of fungi. HP may occur after repeated exposures to an allergen and can result in permanent lung damage.^{5, 6, 7, 8, 9, 10}
- Fungi can cause allergic reactions. The most common symptoms are runny nose, eye irritation, cough, congestion, and aggravation of asthma.^{11, 12}

Fungi are present almost everywhere in indoor and outdoor environments. The most common symptoms of fungal exposure are runny nose, eye irritation, cough, congestion, and aggravation of asthma. Although there is evidence documenting severe health effects of fungi in humans, most of this evidence is derived from ingestion of contaminated foods (i.e., grain and peanut products) or occupational exposures in agricultural settings where inhalation exposures were very high.^{13, 14} With the possible exception of remediation to very heavily contaminated indoor environments, such high level exposures are not expected to occur while performing remedial work.¹⁵

There have been reports linking health effects in office workers to offices contaminated with moldy surfaces and in residents of homes contaminated with fungal growth.^{12, 16, 17, 18, 19, 20} Symptoms, such as fatigue, respiratory ailments, and eye irritation were typically observed in these cases.

Some studies have suggested an association between SC and pulmonary hemorrhage/hemosiderosis in infants, generally those less than six months old. Pulmonary hemosiderosis is an uncommon condition that results from bleeding in the lungs. The cause of this condition is unknown, but may result from a combination of environmental contaminants and conditions (e.g., smoking, other microbial contaminants, and water-damaged homes), and currently its association with SC is unproven.^{21, 22, 23}

The focus of this guidance document addresses mold contamination of building components (walls, ventilation systems, support beams, etc.) that are chronically moist or water damaged. Occupants should address common household sources of mold, such as mold found in bathroom tubs or between tiles with household cleaners. Moldy food (e.g., breads, fruits, etc.) should be discarded.

This document is not a legal mandate and should be used as a guideline. Currently there are no United States Federal, New York State, or New York City regulations for evaluating potential health effects of fungal contamination and remediation. These guidelines are subject to change as more information regarding fungal contaminants becomes available.

[top of page](#)

1. Health Issues

1.1 Health Effects

Inhalation of fungal spores, fragments (parts), or metabolites (e.g., mycotoxins and volatile organic compounds) from a wide variety of fungi may lead to or exacerbate immunologic (allergic) reactions, cause toxic effects, or cause infections.^{11, 12,}

24

There are only a limited number of documented cases of health problems from indoor exposure to fungi. The intensity of

exposure and health effects seen in studies of fungal exposure in the indoor environment was typically much less severe than those that were experienced by agricultural workers but were of a long-term duration.^{5-10, 12, 14, 16-20, 25-27} Illnesses can result from both high level, short-term exposures and lower level, long-term exposures. The most common symptoms reported from exposures in indoor environments are runny nose, eye irritation, cough, congestion, aggravation of asthma, headache, and fatigue.^{11, 12, 16-20}

The presence of fungi on building materials as identified by a visual assessment or by bulk/surface sampling results does not necessitate that people will be exposed or exhibit health effects. In order for humans to be exposed indoors, fungal spores, fragments, or metabolites must be released into the air and inhaled, physically contacted (dermal exposure), or ingested. Whether or not symptoms develop in people exposed to fungi depends on the nature of the fungal material (e.g., allergenic, toxic, or infectious), the amount of exposure, and the susceptibility of exposed persons. Susceptibility varies with the genetic predisposition (e.g., allergic reactions do not always occur in all individuals), age, state of health, and concurrent exposures. For these reasons, and because measurements of exposure are not standardized and biological markers of exposure to fungi are largely unknown, it is not possible to determine "safe" or "unsafe" levels of exposure for people in general.

1.1.1 Immunological Effects

Immunological reactions include asthma, HP, and allergic rhinitis. Contact with fungi may also lead to dermatitis. It is thought that these conditions are caused by an immune response to fungal agents. The most common symptoms associated with allergic reactions are runny nose, eye irritation, cough, congestion, and aggravation of asthma.^{11, 12} HP may occur after repeated exposures to an allergen and can result in permanent lung damage. HP has typically been associated with repeated

heavy exposures in agricultural settings but has also been reported in office settings.^{25, 26, 27} Exposure to fungi through renovation work may also lead to initiation or exacerbation of allergic or respiratory symptoms.

1.1.2 Toxic Effects

A wide variety of symptoms have been attributed to the toxic effects of fungi. Symptoms, such as fatigue, nausea, and headaches, and respiratory and eye irritation have been reported. Some of the symptoms related to fungal exposure are non-specific, such as discomfort, inability to concentrate, and fatigue.^{11, 12, 16-20} Severe illnesses such as ODTS and pulmonary hemosiderosis have also been attributed to fungal exposures.^{5-10, 21, 22}

ODTS describes the abrupt onset of fever, flu-like symptoms, and respiratory symptoms in the hours following a *single, heavy* exposure to dust containing organic material including fungi. It differs from HP in that it is not an immune-mediated disease and does not require repeated exposures to the same causative agent. ODTS may be caused by a variety of biological agents including common species of fungi (e.g., species of *Aspergillus* and *Penicillium*). ODTS has been documented in farm workers handling contaminated material but is also of concern to workers performing renovation work on building materials contaminated with fungi.⁵⁻¹⁰

Some studies have suggested an association between SC and pulmonary hemorrhage/hemosiderosis in infants, generally those less than six months old. Pulmonary hemosiderosis is an uncommon condition that results from bleeding in the lungs. The cause of this condition is unknown, but may result from a combination of environmental contaminants and conditions (e.g., smoking, fungal contaminants and other bioaerosols, and water-damaged homes), and currently its association with SC is unproven.^{21, 22, 23}

1.1.3 Infectious Disease

Only a small group of fungi have been associated with infectious disease. Aspergillosis is an infectious disease that can occur in immunosuppressed persons. Health effects in this population can be severe. Several species of *Aspergillus* are known to cause aspergillosis. The most common is *Aspergillus fumigatus*. Exposure to this common mold, even to high concentrations, is unlikely to cause infection in a healthy person.^{11, 24}

Exposure to fungi associated with bird and bat droppings (e.g., *Histoplasma capsulatum* and *Cryptococcus neoformans*) can lead to health effects, usually transient flu-like illnesses, in healthy individuals. Severe health effects are primarily encountered in immunocompromised persons.^{24, 28, 29}

1.2 Medical Evaluation

Individuals with persistent health problems that appear to be related to fungi or other bioaerosol exposure should see their physicians for a referral to practitioners who are trained in occupational/environmental medicine or related specialties and are knowledgeable about these types of exposures. Infants (less than 12 months old) who are experiencing non-traumatic nosebleeds or are residing in dwellings with damp or moldy conditions and are experiencing breathing difficulties should receive a medical evaluation to screen for alveolar hemorrhage. Following this evaluation, infants who are suspected of having alveolar hemorrhaging should be referred to a pediatric pulmonologist. Infants diagnosed with pulmonary hemosiderosis and/or pulmonary hemorrhaging should not be returned to dwellings until remediation and air testing are completed.

Clinical tests that can determine the source, place, or time of exposure to fungi or their products are not currently available. Antibodies developed by exposed persons to fungal agents can

only document that exposure has occurred. Since exposure to fungi routinely occurs in both outdoor and indoor environments this information is of limited value.

1.3 Medical Relocation

Infants (less than 12 months old), persons recovering from recent surgery, or people with immune suppression, asthma, hypersensitivity pneumonitis, severe allergies, sinusitis, or other chronic inflammatory lung diseases may be at greater risk for developing health problems associated with certain fungi. Such persons should be removed from the affected area during remediation (see Section 3, Remediation). Persons diagnosed with fungal related diseases should not be returned to the affected areas until remediation and air testing are completed.

Except in cases of widespread fungal contamination that are linked to illnesses throughout a building, a building-wide evacuation is not indicated. A trained occupational/environmental health practitioner should base decisions about medical removals in the occupational setting on the results of a clinical assessment.

[top of page](#)

2. Environmental Assessment

The presence of mold, water damage, or musty odors should be addressed immediately. In all instances, any source(s) of water must be stopped and the extent of water damaged determined. Water damaged materials should be dried and repaired. Mold damaged materials should be remediated in accordance with this document (see Section 3, Remediation).

2.1 Visual Inspection

A visual inspection is the most important initial step in identifying a possible contamination problem. The extent of any

water damage and mold growth should be visually assessed. This assessment is important in determining remedial strategies. Ventilation systems should also be visually checked, particularly for damp filters but also for damp conditions elsewhere in the system and overall cleanliness. Ceiling tiles, gypsum wallboard (sheetrock), cardboard, paper, and other cellulosic surfaces should be given careful attention during a visual inspection. The use of equipment such as a boroscope, to view spaces in ductwork or behind walls, or a moisture meter, to detect moisture in building materials, may be helpful in identifying hidden sources of fungal growth and the extent of water damage.

2.2 Bulk/Surface Sampling

- a. Bulk or surface sampling is not required to undertake a remediation. Remediation (as described in Section 3, Remediation) of visually identified fungal contamination should proceed without further evaluation.
- b. Bulk or surface samples may need to be collected to identify specific fungal contaminants as part of a medical evaluation if occupants are experiencing symptoms which may be related to fungal exposure or to identify the presence or absence of mold if a visual inspection is equivocal (e.g., discoloration, and staining).
- c. An individual trained in appropriate sampling methodology should perform bulk or surface sampling. Bulk samples are usually collected from visibly moldy surfaces by scraping or cutting materials with a clean tool into a clean plastic bag. Surface samples are usually collected by wiping a measured area with a sterile swab or by stripping the suspect surface with clear tape. Surface sampling is less destructive than bulk sampling. Other sampling methods may also be available. A laboratory specializing in mycology should be consulted for specific sampling and delivery instructions.

2.3 Air Monitoring

- a. Air sampling for fungi should not be part of a routine assessment. This is because decisions about appropriate remediation strategies can usually be made on the basis of a visual inspection. In addition, air-sampling methods for some fungi are prone to false negative results and therefore cannot be used to definitively rule out contamination.
- b. Air monitoring may be necessary if an individual(s) has been diagnosed with a disease that is or may be associated with a fungal exposure (e.g., pulmonary hemorrhage/hemosiderosis, and aspergillosis).
- c. Air monitoring may be necessary if there is evidence from a visual inspection or bulk sampling that ventilation systems may be contaminated. The purpose of such air monitoring is to assess the extent of contamination throughout a building. It is preferable to conduct sampling while ventilation systems are operating.
- d. Air monitoring may be necessary if the presence of mold is suspected (e.g., musty odors) but cannot be identified by a visual inspection or bulk sampling (e.g., mold growth behind walls). The purpose of such air monitoring is to determine the location and/or extent of contamination.
- e. If air monitoring is performed, for comparative purposes, outdoor air samples should be collected concurrently at an air intake, if possible, and at a location representative of outdoor air. For additional information on air sampling, refer to the American Conference of Governmental Industrial Hygienists' document, "Bioaerosols: Assessment and Control."
- f. Personnel conducting the sampling must be trained in proper air sampling methods for microbial contaminants. A laboratory specializing in mycology should be consulted

for specific sampling and shipping instructions.

2.4 Analysis of Environmental Samples

Microscopic identification of the spores/colonies requires considerable expertise. These services are not routinely available from commercial laboratories. Documented quality control in the laboratories used for analysis of the bulk/surface and air samples is necessary. The American Industrial Hygiene Association (AIHA) offers accreditation to microbial laboratories (Environmental Microbiology Laboratory Accreditation Program (EMLAP)). Accredited laboratories must participate in quarterly proficiency testing (Environmental Microbiology Proficiency Analytical Testing Program (EMPAT)).

Evaluation of bulk/surface and air sampling data should be performed by an experienced health professional. The presence of few or trace amounts of fungal spores in bulk/surface sampling should be considered background. Amounts greater than this or the presence of fungal fragments (e.g., hyphae, and conidiophores) may suggest fungal colonization, growth, and/or accumulation at or near the sampled location.³⁰ Air samples should be evaluated by means of comparison (i.e., indoors to outdoors) and by fungal type (e.g., genera, and species). In general, the levels and types of fungi found should be similar indoors (in non-problem buildings) as compared to the outdoor air. Differences in the levels or types of fungi found in air samples may indicate that moisture sources and resultant fungal growth may be problematic.

[top of page](#)

3. Remediation

In all situations, the underlying cause of water accumulation must be rectified or fungal growth will recur. Any initial water infiltration should be stopped and cleaned immediately. An

immediate response (within 24 to 48 hours) and thorough clean up, drying, and/or removal of water damaged materials will prevent or limit mold growth. If the source of water is elevated humidity, relative humidity should be maintained at levels below 60% to inhibit mold growth.³¹ Emphasis should be on ensuring proper repairs of the building infrastructure, so that water damage and moisture buildup does not recur.

Five different levels of abatement are described below. The size of the area impacted by fungal contamination primarily determines the type of remediation. The sizing levels below are based on professional judgement and practicality; currently there is not adequate data to relate the extent of contamination to frequency or severity of health effects. **The goal of remediation is to remove or clean contaminated materials in a way that prevents the emission of fungi and dust contaminated with fungi from leaving a work area and entering an occupied or non-abatement area, while protecting the health of workers performing the abatement.** The listed remediation methods were designed to achieve this goal, however, due to the general nature of these methods it is the responsibility of the people conducting remediation to ensure the methods enacted are adequate. The listed remediation methods are not meant to exclude other similarly effective methods. Any changes to the remediation methods listed in these guidelines, however, should be carefully considered prior to implementation.

Non-porous (e.g., metals, glass, and hard plastics) and semi-porous (e.g., wood, and concrete) materials that are structurally sound and are visibly moldy can be cleaned and reused. Cleaning should be done using a detergent solution. Porous materials such as ceiling tiles and insulation, and wallboards with more than a small area of contamination should be removed and discarded. Porous materials (e.g., wallboard, and fabrics) that can be cleaned, can be reused, but should be discarded if possible. A professional restoration consultant should be contacted when restoring porous materials with more than a small area of fungal contamination. All materials to be reused should be dry and visibly free from mold. Routine inspections should be conducted to confirm the effectiveness of remediation

work.

The use of gaseous, vapor-phase, or aerosolized biocides for remedial purposes is **not** recommended. The use of biocides in this manner can pose health concerns for people in occupied spaces of the building and for people returning to the treated space if used improperly. Furthermore, the effectiveness of these treatments is unproven and does not address the possible health concerns from the presence of the remaining non-viable mold. For additional information on the use of biocides for remedial purposes, refer to the American Conference of Governmental Industrial Hygienists' document, "Bioaerosols: Assessment and Control."

3.1 Level I: Small Isolated Areas (10 sq. ft or less) - e.g., ceiling tiles, small areas on walls

- a. Remediation can be conducted by regular building maintenance staff. Such persons should receive training on proper clean up methods, personal protection, and potential health hazards. This training can be performed as part of a program to comply with the requirements of the OSHA Hazard Communication Standard (29 CFR 1910.1200).
- b. Respiratory protection (e.g., N95 disposable respirator), in accordance with the OSHA respiratory protection standard (29 CFR 1910.134), is recommended. Gloves and eye protection should be worn.
- c. The work area should be unoccupied. Vacating people from spaces adjacent to the work area is not necessary but is recommended in the presence of infants (less than 12 months old), persons recovering from recent surgery, immune suppressed people, or people with chronic inflammatory lung diseases (e.g., asthma, hypersensitivity pneumonitis, and severe allergies).
- d. Containment of the work area is not necessary. Dust suppression methods, such as misting (not soaking)

surfaces prior to remediation, are recommended.

- e. Contaminated materials that cannot be cleaned should be removed from the building in a sealed plastic bag. There are no special requirements for the disposal of moldy materials.
- f. The work area and areas used by remedial workers for egress should be cleaned with a damp cloth and/or mop and a detergent solution.
- g. All areas should be left dry and visibly free from contamination and debris.

3.2 Level II: Mid-Sized Isolated Areas (10 - 30 sq. ft.) - e.g., individual wallboard panels.

- a. Remediation can be conducted by regular building maintenance staff. Such persons should receive training on proper clean up methods, personal protection, and potential health hazards. This training can be performed as part of a program to comply with the requirements of the OSHA Hazard Communication Standard (29 CFR 1910.1200).
- b. Respiratory protection (e.g., N95 disposable respirator), in accordance with the OSHA respiratory protection standard (29 CFR 1910.134), is recommended. Gloves and eye protection should be worn.
- c. The work area should be unoccupied. Vacating people from spaces adjacent to the work area is not necessary but is recommended in the presence of infants (less than 12 months old), persons having undergone recent surgery, immune suppressed people, or people with chronic inflammatory lung diseases (e.g., asthma, hypersensitivity pneumonitis, and severe allergies).
- d. The work area should be covered with a plastic sheet(s) and

sealed with tape before remediation, to contain dust/debris.

- e. Dust suppression methods, such as misting (not soaking) surfaces prior to remediation, are recommended.
- f. Contaminated materials that cannot be cleaned should be removed from the building in sealed plastic bags. There are no special requirements for the disposal of moldy materials.
- g. The work area and areas used by remedial workers for egress should be HEPA vacuumed (a vacuum equipped with a High-Efficiency Particulate Air filter) and cleaned with a damp cloth and/or mop and a detergent solution.
- h. All areas should be left dry and visibly free from contamination and debris.

3.3 Level III: Large Isolated Areas (30 - 100 square feet) - e.g., several wallboard panels.

A health and safety professional with experience performing microbial investigations should be consulted prior to remediation activities to provide oversight for the project.

The following procedures *at a minimum* are recommended:

- a. Personnel trained in the handling of hazardous materials and equipped with respiratory protection, (e.g., N95 disposable respirator), in accordance with the OSHA respiratory protection standard (29 CFR 1910.134), is recommended. Gloves and eye protection should be worn.
- b. The work area and areas directly adjacent should be covered with a plastic sheet(s) and taped before remediation, to contain dust/debris.
- c. Seal ventilation ducts/grills in the work area and areas directly adjacent with plastic sheeting.

- d. The work area and areas directly adjacent should be unoccupied. Further vacating of people from spaces near the work area is recommended in the presence of infants (less than 12 months old), persons having undergone recent surgery, immune suppressed people, or people with chronic inflammatory lung diseases (e.g., asthma, hypersensitivity pneumonitis, and severe allergies).
- e. Dust suppression methods, such as misting (not soaking) surfaces prior to remediation, are recommended.
- f. Contaminated materials that cannot be cleaned should be removed from the building in sealed plastic bags. There are no special requirements for the disposal of moldy materials.
- g. The work area and surrounding areas should be HEPA vacuumed and cleaned with a damp cloth and/or mop and a detergent solution.
- h. All areas should be left dry and visibly free from contamination and debris.

If abatement procedures are expected to generate a lot of dust (e.g., abrasive cleaning of contaminated surfaces, demolition of plaster walls) or the visible concentration of the fungi is heavy (blanket coverage as opposed to patchy), then it is recommended that the remediation procedures for Level IV are followed.

3.4 Level IV: Extensive Contamination (greater than 100 contiguous square feet in an area)

A health and safety professional with experience performing microbial investigations should be consulted prior to remediation activities to provide oversight for the project. The following procedures are recommended:

- a. Personnel trained in the handling of hazardous materials equipped with:

- i. Full-face respirators with high efficiency particulate air (HEPA) cartridges
 - ii. Disposable protective clothing covering both head and shoes
 - iii. Gloves
- b. Containment of the affected area:
 - i. Complete isolation of work area from occupied spaces using plastic sheeting sealed with duct tape (including ventilation ducts/grills, fixtures, and any other openings)
 - ii. The use of an exhaust fan with a HEPA filter to generate negative pressurization
 - iii. Airlocks and decontamination room
- c. Vacating people from spaces adjacent to the work area is not necessary but is recommended in the presence of infants (less than 12 months old), persons having undergone recent surgery, immune suppressed people, or people with chronic inflammatory lung diseases (e.g., asthma, hypersensitivity pneumonitis, and severe allergies).
- d. Contaminated materials that cannot be cleaned should be removed from the building in sealed plastic bags. The outside of the bags should be cleaned with a damp cloth and a detergent solution or HEPA vacuumed in the decontamination chamber prior to their transport to uncontaminated areas of the building. There are no special requirements for the disposal of moldy materials.
- e. The contained area and decontamination room should be HEPA vacuumed and cleaned with a damp cloth and/or mop with a detergent solution and be visibly clean prior to the removal of isolation barriers.
- f. Air monitoring should be conducted prior to occupancy to

determine if the area is fit to reoccupy.

3.5 Level V: Remediation of HVAC Systems

3.5.1 A Small Isolated Area of Contamination (<10 square feet) in the HVAC System

- a. Remediation can be conducted by regular building maintenance staff. Such persons should receive training on proper clean up methods, personal protection, and potential health hazards. This training can be performed as part of a program to comply with the requirements of the OSHA Hazard Communication Standard (29 CFR 1910.1200).
- b. Respiratory protection (e.g., N95 disposable respirator), in accordance with the OSHA respiratory protection standard (29 CFR 1910.134), is recommended. Gloves and eye protection should be worn.
- c. The HVAC system should be shut down prior to any remedial activities.
- d. The work area should be covered with a plastic sheet(s) and sealed with tape before remediation, to contain dust/debris.
- e. Dust suppression methods, such as misting (not soaking) surfaces prior to remediation, are recommended.
- f. Growth supporting materials that are contaminated, such as the paper on the insulation of interior lined ducts and filters, should be removed. Other contaminated materials that cannot be cleaned should be removed in sealed plastic bags. There are no special requirements for the disposal of moldy materials.
- g. The work area and areas immediately surrounding the work area should be HEPA vacuumed and cleaned with a damp cloth and/or mop and a detergent solution.

- h. All areas should be left dry and visibly free from contamination and debris.
- i. A variety of biocides are recommended by HVAC manufacturers for use with HVAC components, such as, cooling coils and condensation pans. HVAC manufacturers should be consulted for the products they recommend for use in their systems.

3.5.2 Areas of Contamination (>10 square feet) in the HVAC System

A health and safety professional with experience performing microbial investigations should be consulted prior to remediation activities to provide oversight for remediation projects involving more than a small isolated area in an HVAC system. The following procedures are recommended:

- a. Personnel trained in the handling of hazardous materials equipped with:
 - i. Respiratory protection (e.g., N95 disposable respirator), in accordance with the OSHA respiratory protection standard (29 CFR 1910.134), is recommended.
 - ii. Gloves and eye protection
 - iii. Full-face respirators with HEPA cartridges and disposable protective clothing covering both head and shoes should be worn if contamination is greater than 30 square feet.
- b. The HVAC system should be shut down prior to any remedial activities.
- c. Containment of the affected area:
 - i. Complete isolation of work area from the other areas

- of the HVAC system using plastic sheeting sealed with duct tape.
- ii. The use of an exhaust fan with a HEPA filter to generate negative pressurization.
 - iii. Airlocks and decontamination room if contamination is greater than 30 square feet.
- d. Growth supporting materials that are contaminated, such as the paper on the insulation of interior lined ducts and filters, should be removed. Other contaminated materials that cannot be cleaned should be removed in sealed plastic bags. When a decontamination chamber is present, the outside of the bags should be cleaned with a damp cloth and a detergent solution or HEPA vacuumed prior to their transport to uncontaminated areas of the building. There are no special requirements for the disposal of moldy materials.
- e. The contained area and decontamination room should be HEPA vacuumed and cleaned with a damp cloth and/or mop and a detergent solution prior to the removal of isolation barriers.
- f. All areas should be left dry and visibly free from contamination and debris.
- g. Air monitoring should be conducted prior to re-occupancy with the HVAC system in operation to determine if the area (s) served by the system are fit to reoccupy.
- h. A variety of biocides are recommended by HVAC manufacturers for use with HVAC components, such as, cooling coils and condensation pans. HVAC manufacturers should be consulted for the products they recommend for use in their systems.

[top of page](#)

4. Hazard Communication

When fungal growth requiring large-scale remediation is found, the building owner, management, and/or employer should notify occupants in the affected area(s) of its presence. Notification should include a description of the remedial measures to be taken and a timetable for completion. Group meetings held before and after remediation with full disclosure of plans and results can be an effective communication mechanism. Individuals with persistent health problems that appear to be related to bioaerosol exposure should see their physicians for a referral to practitioners who are trained in occupational/environmental medicine or related specialties and are knowledgeable about these types of exposures. Individuals seeking medical attention should be provided with a copy of all inspection results and interpretation to give to their medical practitioners.

[top of page](#)

Conclusion

In summary, the prompt remediation of contaminated material and infrastructure repair must be the primary response to fungal contamination in buildings. The simplest and most expedient remediation that properly and safely removes fungal growth from buildings should be used. In all situations, the underlying cause of water accumulation must be rectified or the fungal growth will recur. Emphasis should be placed on preventing contamination through proper building maintenance and prompt repair of water damaged areas.

Widespread contamination poses much larger problems that must be addressed on a case-by-case basis in consultation with a health and safety specialist. Effective communication with building occupants is an essential component of all remedial efforts. Individuals with persistent health problems should see their physicians for a referral to practitioners who are trained in occupational/environmental medicine or related specialties and are knowledgeable about these

types of exposures.

[top of page](#)

Notes and References

1. Bata A, Harrach B, Kalman U, Kis-tamas A, Lasztity R. Macrocyclic Trichothecene Toxins Produced by *Stachybotrys atra* Strains Isolated in Middle Europe. *Applied and Environmental Microbiology* 1985; **49**:678-81.
2. Jarvis B, "Mycotoxins and Indoor Air Quality," *Biological Contaminants in Indoor Environments, ASTM STP 1071*, Morey P, Feely Sr. J, Otten J, Editors, American Society for Testing and Materials, Philadelphia, 1990.
3. Yang C, Johannig E, "Airborne Fungi and Mycotoxins," *Manual of Environmental Microbiology*, Hurst C, Editor in Chief, ASM Press, Washington, D.C., 1996
4. Jarvis B, Mazzola E. Macrocyclic and Other Novel Trichothecenes: Their Structure, Synthesis, and Biological Significance. *Acc. Chem. Res.* 1982; **15**:388-95.
5. Von Essen S, Robbins R, Thompson A, Rennard S. Organic Dust Toxic Syndrome: An Acute Febrile Reaction to Organic Dust Exposure Distinct from Hypersensitivity Pneumonitis. *Clinical Toxicology* 1990; **28**(4):389-420.
6. Richerson H. Unifying Concepts Underlying the Effects of Organic Dust Exposures. *American Journal of Industrial Medicine* 1990; **17**:139-42.
7. Malmberg P, Rask-Andersen A, Lundholm M, Palmgren U. Can Spores from Molds and Actinomycetes Cause an Organic Dust Toxic Syndrome Reaction?. *American Journal of Industrial Medicine* 1990; **17**:109-10.
8. Malmberg P. Health Effects of Organic Dust Exposure in Dairy Farmers. *American Journal of Industrial Medicine* 1990; **17**:7-15.
9. Yoshida K, Masayuki A, Shukuro A. Acute Pulmonary Edema in a Storehouse of Moldy Oranges: A Severe Case of the Organic Dust Toxic Syndrome. *Archives of Environmental Health* 1989; **44**(6): 382-84.

10. Lecours R, Laviolette M, Cormier Y. Bronchoalveolar Lavage in Pulmonary Mycotoxicosis. *Thorax* 1986; **41**:924-6.
11. Levetin E. "Fungi," *Bioaerosols*, Burge H, Editor, CRC Press, Boca Raton, Florida, 1995.
12. Husman T. Health Effects of Indoor-air Microorganisms. *Scand J Work Environ Health* 1996; **22**:5-13.
13. Miller J D. Fungi and Mycotoxins in Grain: Implications for Stored Product Research. *J Stored Prod Res* 1995; **31**(1):1-16.
14. Cookingham C, Solomon W. "Bioaerosol-Induced Hypersensitivity Diseases," *Bioaerosols*, Burge H, Editor, CRC Press, Boca Raton, Florida, 1995.
15. Rautiala S, Reponen T, Nevalainen A, Husman T, Kalliokoski P. Control of Exposure to Airborne Viable Microorganisms During Remediation of Moldy Buildings; Report of Three Case Studies. *American Industrial Hygiene Association Journal* 1998; **59**:455-60.
16. Dales R, Zwanenburg H, Burnett R, Franklin C. Respiratory Health Effects of Home Dampness and Molds among Canadian Children. *American Journal of Epidemiology* 1991; **134**(2): 196-203.
17. Hodgson M, Morey P, Leung W, Morrow L, Miller J D, Jarvis B, Robbins H, Halsey J, Storey E. Building-Associated Pulmonary Disease from Exposure to *Stachybotrys chartarum* and *Aspergillus versicolor*. *Journal of Occupational and Environmental Medicine* 1998; **40**(3)241-9.
18. Croft W, Jarvis B, Yatawara C. Airborne Outbreak of Trichothecene Toxicosis. *Atmospheric Environment* 1986; **20**(3)549-52.
19. DeKoster J, Thorne P. Bioaerosol Concentrations in Noncomplaint, Complaint, and Intervention Homes in the Midwest. *American Industrial Hygiene Association Journal* 1995; **56**:573-80.
20. Johanning E, Biagini R, Hull D, Morey P, Jarvis B, Landbergis P. Health and Immunological Study Following Exposure to Toxicogenic Fungi (*Stachybotrys chartarum*) in a Water-Damaged Office Environment. *Int Arch Occup Environ Health* 1996; **68**:207-18.
21. Montana E, Etzel R, Allan T, Horgan T, Dearborn D. Environmental Risk Factor Associated with Pediatric Idiopathic Pulmonary Hemorrhage

- and Hemosiderosis in a Cleveland Community. *Pediatrics* 1997; **99**(1)
22. Etzel R, Montana E, Sorenson W G, Kullman G, Allan T, Dearborn D. Acute Pulmonary Hemorrhage in Infants Associated with Exposure to *Stachybotrys atra* and Other Fungi. *Ach Pediatr Adolesc Med* 1998; **152**:757-62.
 23. CDC. Update: Pulmonary Hemorrhage/Hemosiderosis Among Infants --- Cleveland, Ohio, 1993 - 1996. *MMWR* 2000; **49**(9): 180-4.
 24. Burge H, Otten J. "Fungi," *Bioaerosols Assessment and Control*, Macher J, Editor, American Conference of Industrial Hygienists, Cincinnati, Ohio, 1999.
 25. do Pico G. Hazardous Exposure and Lung Disease Among Farm Workers. *Clinics in Chest Medicine* 1992; **13**(2):311-28.
 26. Hodgson M, Morey P, Attfield M, Sorenson W, Fink J, Rhodes W, Visvesvara G. Pulmonary Disease Associated with Cafeteria Flooding. *Archives of Environmental Health* 1985; **40**(2):96-101.
 27. Weltermann B, Hodgson M, Storey E, DeGraff, Jr. A, Bracker A, Groseclose S, Cole S, Cartter M, Phillips D. Hypersensitivity Pneumonitis: A Sentinel Event Investigation in a Wet Building. *American Journal of Industrial Medicine* 1998; **34**:499-505.
 28. Band J. "Histoplasmosis," *Occupational Respiratory Diseases*, Merchant J, Editor, U.S. Department of Health and Human Services, Washington D.C., 1986.
 29. Bertolini R. "Histoplasmosis A Summary of the Occupational Health Concern," Canadian Centre for Occupational Health and Safety. Hamilton, Ontario, Canada, 1988.
 30. Yang C. P&K Microbiology Services, Inc. Microscopic Examination of Sticky Tape or Bulk Samples for the Evaluation and Identification of Fungi. Cherry Hill, New Jersey.
 31. American Society of Heating, Refrigerating and Air-Conditioning Engineers, Inc. Thermal Environmental Conditions for Human Occupancy - ASHRAE Standard (ANSI/ASHRAE 55-1992). Atlanta, Georgia, 1992.

[top of page](#)

Acknowledgments

The New York City Department of Health would like to thank the following individuals and organizations for participating in the revision of these guidelines. Please note that these guidelines do not necessarily reflect the opinions of the participants nor their organizations.

| Name | Company/Institution |
|----------------------|---|
| Dr. Susan Klitzman | Hunter College |
| Dr. Philip Morey | AQS Services, Inc |
| Dr. Donald Ahearn | Georgia State University |
| Dr. Sidney Crow | Georgia State University |
| Dr. J. David Miller | Carleton University |
| Dr. Bruce Jarvis | University of Maryland at College Park |
| Mr. Ed Light | Building Dynamics, LLC |
| Dr. Chin Yang | P&K Microbiology Services, Inc |
| Dr. Harriet Burge | Harvard School of Public Health |
| Dr. Dorr Dearborn | Rainbow Children's Hospital |
| Mr. Eric Esswein | National Institute for Occupational Safety and Health |
| Dr. Ed Horn | The New York State Department of Health |
| Dr. Judith Schreiber | The New York State Department of Health |
| Mr. Gregg Recer | The New York State Department of Health |
| Dr. Gerald Llewellyn | State of Delaware, Division of Public Health |
| Mr. Daniel Price | Interface Research Corporation |
| Ms. Sylvia Pryce | The NYC Citywide Office of Occupational Safety and Health |
| Mr. Armando Chamorro | Ambient Environmental |

| | |
|-----------------------------|---|
| Ms. Marie-Alix d'Halewyn | Laboratoire de santé publique du Québec |
| Dr. Elissa A. Favata | Environmental and Occupational Health Associates |
| Dr. Harriet Ammann | Washington State Department of Health |
| Mr. Terry Allan | Cuyahoga County Board of Health |

We would also like to thank the many others who offered opinions, comments, and assistance at various stages during the development of these guidelines.

Christopher D'Andrea, M.S. of the Environmental and Occupational Disease Epidemiology Unit, was the editor of this document.

For further information regarding this document please contact the New York City Department of Health at (212) 788-4290 / 4288.

(April 2000) January 2002

ATTACHMENT 2

MCI ATCT MOLD REMEDIATION PROJECT CLEARANCE PROTOCOL

Mold Remediation Project Clearance Protocol

Kansas City Airport Traffic Control Tower (MCI ATCT)

PREPARED FOR:

FEDERAL AVIATION ADMINISTRATION
CENTRAL REGION
901 LOCUST
KANSAS CITY, MISSOURI 64106

March 28, 2007



PREPARED BY:

Barbara Hebert, CIH (NISC II)

The MCI ATCT Microbiological Remediation and Restoration Project will include the removal of mold-contaminated gypsum board, shaft liner, insulation, and pipe insulation followed by the partial restoration to restore the integrity of fire-rated partitions.

Beginning in June 2007 and extending through July 2007 the project will be performed in the Cab Level stairs, Rooms SJ1, 11TS5, 11TS5A, 11TS6, 11th Floor Outer Ring, 10TS4, 10TS5, 8TS1, 8TS5, 8TS6, 4TS3, 3TS3, 3TS5, 2TS5, and G4.

After Rooms SJ1, 11TS5, 10TS5, and 3TS5 have passed a thorough visual inspection, and before the outer containment barrier is removed, clearance mold spore air sampling will be performed. All remaining rooms shall be cleared by visual inspection.

Five consecutive samples will be collected inside the containment area using a high volume air sampler and Zefon Air-O-Cell® cassettes. Sampling will be conducted at a flow rate of 15 liters per minute for a period of five minutes each, resulting in a collection volume of 75 liters of air. Should visibly dusty environmental conditions exist inside the containment area, the sample collection period may be reduced to one-minute intervals, in order to reduce the collection of non-microbial particulates that can mask the presence of mold spores.

Three consecutive samples will be collected outside the containment area, but inside the ATCT in a noncomplaint area, in the same manner as above. Sampling will be conducted at a flow rate of 15 liters per minute for a period of five minutes each, resulting in a collection volume of 75 liters of air.

Two consecutive samples will be collected outside of the building, in the same manner as above. Sampling will be conducted at a flow rate of 15 liters per minute for a period of 10 minutes each, resulting in a collection volume of 150 liters of air.

For all samples collected, the high volume air sampler will be calibrated before and after use.

All samples, one lab blank, and a completed Chain of Custody form will be sent to Aerotech Laboratories, Inc., by Federal Express Priority Overnight delivery. The samples will be mailed in a rigid container or box. There is no additional temperature handling requirement. Aerotech Laboratories, accredited by the American Industrial Hygiene Association's (AIHA) Environmental Microbiology Laboratory Accreditation Program (EMLAP), will conduct the analysis.

All samples will be clearly labeled. The sample identification number appearing on the cassette **must** match the identification number shown on the Chain of Custody form. The samples will be analyzed in accordance with Aerotech Method A001 (equivalent to the cassette manufacturer's recommended analytical procedure) via light microscopy at 600X magnification, with the entire slide (100% of the sample) being analyzed. The results will be reported as a total fungal spore count, in counts per cubic meter (counts/M³), which includes both viable and non-

viable spores. The Chain of Custody form and an example Aerotech Laboratories sampling report are shown as Attachments 1 and 2, respectively.

The area will be considered "clean" when the average airborne total mold spore concentration measured inside the containment area is not statistically different from the average airborne concentration measured outside the containment area, AND the genus level constituents are similar for all samples taken inside the containment, inside the building (but outside of the containment) and outside of the building.

Statistical significance may be determined in the following manner:

A. All containment sample airborne total concentration levels are lower than those taken from outside the containment, or

B. The Z-test score is less than or equal to 1.65 Standard Deviations from the Mean, indicating a 90% confidence interval. The Z-test is carried out by calculating:

$$Z = \frac{Y_I - Y_O}{0.8 (1/n_I + 1/n_O)^{1/2}}$$

where Y_I is the average of the natural logarithms of the inside samples, Y_O is the average of the natural logarithms of the outside samples, n_I is the number of inside samples and n_O is the number of outside samples.

Alternative A shall be considered first, then if necessary, Alternative B. Should the calculated Z-test score exceed 1.65, the abatement area must be recleaned. An additional set of 10 samples must then be collected, as defined above, in order to establish clearance.

Once the abatement area has passed the clearance criteria, the outer containment barrier will be removed and the room will be available for re-occupancy.

Visual inspections and clearance air sampling will be performed upon completion of the mold remediation, but prior to the re-installation of new building materials.

The visual inspection, clearance air sampling and air sampling data interpretation will be conducted by the government-retained National Airspace System Implementation Support Contract (NISC II) Certified Industrial Hygienist.

Attachment 1

Chain of Custody Form

Attachment 2

Aerotech Laboratories

Total Mold Spore Sampling Report



AEROTECH LABORATORIES, INC.

Federal Aviation Administration
 801 Locust, Room 200A
 Kansas City, MO 64108
 Attn: Barbara Hobart

AHA EMLAP No. 102297
Total Fungal Spore, Mycelia and Pollen Counts-Air
 Aerotech Method: A001

Lab Number: A-009-0588
 Project Name:
 Date Received: 9/4/2003
 Date Reported: 9/5/2003

| Lab Number | 1 | | | | 2 | | | | 3 | | | | 4 | | | |
|-------------------------------------|-------------------------------------|----------------------|-----|-----|-------------------------------------|----------------------|-----|-----|-------------------------------------|----------------------|-----|-----|-------------------------------------|----------------------|-----|-----|
| Sample Identification | | | | | | | | | | | | | | | | |
| Volume(M ³) | 0.0750 | | | | 0.0750 | | | | 0.1500 | | | | 0.0750 | | | |
| Media | Air-O-Cell™ Cassette | | | | Air-O-Cell™ Cassette | | | | Air-O-Cell™ Cassette | | | | Air-O-Cell™ Cassette | | | |
| Date Analyzed | 9/5/2003 | | | | 9/5/2003 | | | | 9/5/2003 | | | | 9/5/2003 | | | |
| Percent Of Trace Analyzed | 100% of Trace at 600X Magnification | | | | 100% of Trace at 600X Magnification | | | | 100% of Trace at 600X Magnification | | | | 100% of Trace at 600X Magnification | | | |
| Debris Rating | 2 | | | | 2 | | | | 3 | | | | 3 | | | |
| Analyte | Total Count | Count/M ³ | | | Total Count | Count/M ³ | | | Total Count | Count/M ³ | | | Total Count | Count/M ³ | | |
| | | Result | D L | % | | Result | D L | % | | Result | D L | % | | Result | D L | % |
| Mycelial Fragments | 2 | 27 | 13 | n/a | 10 | 133 | 13 | n/a | 17 | 113 | 7 | n/a | 13 | 173 | 13 | n/a |
| Pollen | <1 | <13 | 13 | n/a | 1 | 13 | 13 | n/a | 11 | 73 | 7 | n/a | <1 | <13 | 13 | n/a |
| Total Fungal Spores | 37 | 493 | 13 | 100 | 82 | 1,227 | 13 | 100 | 1,796 | 11,873 | 7 | 100 | 157 | 2,083 | 13 | 100 |
| | Fungal Spore Identification | | | | Fungal Spore Identification | | | | Fungal Spore Identification | | | | Fungal Spore Identification | | | |
| <i>Aspergillus</i> | 2 | 27 | 13 | 5 | 3 | 40 | 13 | 3 | 48 | 320 | 7 | 3 | 2 | 27 | 13 | 1 |
| <i>Americosporus</i> | 5 | 67 | 13 | 14 | 11 | 147 | 13 | 12 | 11 | 73 | 7 | <1 | 34 | 453 | 13 | 22 |
| <i>Articulosium</i> | | | | | | | | | 2 | 13 | 7 | <1 | | | | |
| <i>Ascosporus</i> | 7 | 93 | 13 | 19 | 20 | 287 | 13 | 22 | 126 | 840 | 7 | 7 | 43 | 573 | 13 | 27 |
| <i>Aspergillus/Penicillium-Like</i> | | | | | 5 | 67 | 13 | 5 | | | | | 2 | 27 | 13 | 1 |
| <i>Basidiospores</i> | 15 | 200 | 13 | 41 | 38 | 507 | 13 | 41 | 90 | 600 | 7 | 5 | 54 | 720 | 13 | 34 |
| <i>Bipolaris/Dreschlera</i> | | | | | | | | | | | | | | | | |
| <i>Botrytis</i> | | | | | | | | | | | | | | | | |
| <i>Chaetomium</i> | | | | | | | | | | | | | | | | |
| <i>Cladosporium</i> | 7 | 83 | 13 | 19 | 10 | 133 | 13 | 11 | 1,500 | 10,000 | 7 | 84 | 17 | 227 | 13 | 11 |
| <i>Curvularia</i> | | | | | | | | | | | | | 1 | 13 | 13 | <1 |
| <i>Epicoccum</i> | | | | | | | | | | | | | | | | |
| <i>Fusarium</i> | | | | | | | | | | | | | | | | |
| <i>Memnoniella</i> | | | | | | | | | | | | | | | | |
| <i>Nigrospora</i> | | | | | 1 | 13 | 13 | 1 | | | | | | | | |
| <i>Oidium/Paronospora</i> | | | | | | | | | 1 | 7 | 7 | <1 | | | | |
| <i>Pitheomyces/Liocladium</i> | | | | | | | | | | | | | | | | |
| <i>Fusis</i> | | | | | | | | | 2 | 13 | 7 | <1 | | | | |
| <i>Smuts/Mycosporales/Panicola</i> | 1 | 13 | 13 | 3 | 3 | 40 | 13 | 3 | 9 | 60 | 7 | <1 | 3 | 40 | 13 | 2 |
| <i>Stachybotrys</i> | | | | | | | | | | | | | | | | |
| <i>Stemphylium</i> | | | | | | | | | | | | | | | | |
| <i>Toxaria</i> | | | | | | | | | 1 | 7 | 7 | <1 | | | | |
| Unidentified Conidia | | | | | 1 | 13 | 13 | 1 | 8 | 40 | 7 | <1 | 1 | 13 | 13 | <1 |
| Date Qualified | | | | | | | | | | | | | | | | |

Laboratory Manager: *H. H. Beck* Project Manager: *John R. Ke* A001 Page 1 of 2
 A001 AH CLIENT REPORT FORM, P 1 of 2, REVISION 02, 071003, VPCS

SUPPLEMENTAL STATEMENT OF WORK
MICROBIOLOGICAL REMEDIATION AND PARTIAL RESTORATION
FOR
FEDERAL AVIATION ADMINISTRATION
KANSAS CITY AIRPORT TRAFFIC CONTROL TOWER (MCI ATCT)
KANSAS CITY, MISSOURI

FACILITY LOCATION. The facility is located at the Kansas City International Airport. The address is #4 International Square, Kansas City, MO 64153.

The Supplemental Statement of Work (SSOW) identifies additional requirements or restrictions associated with performing the work required in the Statement of Work (SOW) and provides additional information such as floor plans and notes to further clarify the remediation work required by the SOW. It also identifies any additional work required under this contract to restore fire rated partitions, provide access for visual inspection of concealed areas, to correct certain moisture related problems in the facility, to repair certain building components with water damage, to water test areas of potential leaks, or to perform other work identified as part of the remediation and restoration of the facility. The SSOW provides mandatory requirements for scheduling and sequencing the work.

1.0 WORK SUMMARY. The Contractor shall furnish all labor, material, equipment, tools, supplies, transportation, etc. required to complete all work defined in the SOW and SSOW. All work performed and all materials and equipment used shall be approved by the Contracting Officer's Technical Representative (COTR). This shall include, but not be limited to, testing, inspection, scheduling, reporting, submittals, and installation in accordance with manufacturer's written instructions and recommendations.

The work includes but is not limited to the following:

1. Perform all microbiological remediation work identified in the SOW including establishment of containment areas and negative air ventilation systems; removal of water damaged or contaminated gypsum board; removal of contaminated insulation; removal of water damaged or contaminated pipe insulation; cleaning of HVAC supply, return, or exhaust grilles, registers, or diffusers; vacuuming dust on the covers of ceiling mounted speakers; vacuuming contaminated dust on surfaces identified throughout the facility; cleaning and wet wiping walls and surfaces identified throughout the facility such as in stairwells, elevator corridors, and the elevator shaft; and clean up and removal of contaminated debris. Quantities and locations are defined in the SOW and are further defined or clarified through the floor plans and notes in the appendix.

2. Cut and frame openings and install access panels in walls and ceilings where indicated on the floor plans and notes in the appendix.
3. Perform partial restoration of the facility to restore the integrity of fire rated walls and partitions. Install gypsum board (taped and finished) at removal/remediation locations to restore all fire rated walls and partitions. Includes patching openings identified that were cut in walls during the evaluation for mold. Replace any contaminated insulation removed from walls during remediation. Restore existing vapor barriers. Includes painting walls in occupied portions of the building. Quantities and locations are defined and clarified through the floor plans and notes in the appendix.
4. Insulate piping throughout the facility where identified. The quantities and locations are defined and clarified in the SOW and through the floor plans and notes in the appendix.
5. Remove door and frame, 11TS5A, and a portion of the wall between room 11TS5 and 11TS5A. Install a header to support the remaining wall above and install gypsum board to restore the fire rated wall. Install a strut rack between the floor and header to support the existing wall mounted electric panel. Remove conduit and wiring to the light switch for room 11TS5A and rewire all lights to operate from the existing switch for room 11TS5.
6. Install and remove temporary supports and walk boards between the perimeter wall and precast panels to allow for a visual inspection of the exterior side of the 1" shaft liner panels on the west, north, and east sides of the Subjunction Level.
7. Modify the existing drain line and clean out under the Control Cab sink and install a drip pan to prevent water damage to the gypsum board below when the clean out must be opened for maintenance.
8. Perform work listed to prevent water infiltration into the building such as sealing openings in the handrail posts on the Junction Level and installing water-stops (angles) at drains in Subjunction Level air shafts.
9. Clean out/auger drain lines serving the Control Cab sink and the floor drain for the humidifier in the SW corner of room SJ1.
10. The contract includes options for additional work based on funding availability and includes additional painting, restoration of water damage, replacement of stationary louvers in the exterior wall at the third and fourth floor levels and application of spray on insulation on steel surfaces in the ASDE Penthouse and Vestibule to prevent condensation.

The work referenced above shall be staged and sequenced as defined herein and coordinated with the FAA. The facility will remain operational and occupied throughout the performance of work required by this contract. The Contractor shall plan, schedule, sequence, and execute the work in a manner that will minimize disruptions to facility operations.

- 1.1 SCHEDULE AND SEQUENCE.** The Contractor shall plan, schedule, phase, and execute the work in accordance with the following constraints and sequence. Time or duration constraints have been placed on completion of all work in certain rooms and phases as indicated below based on FAA operational needs. Restoration of all areas shall take place immediately after the completion of microbiological remediation, unless noted otherwise, in order to return the areas to service as soon as possible. The Contractor shall meet with the COTR on a daily basis to review the work planned for that day and the following day.
- a. All work in the stairwells shall be completed before work begins in the elevator shaft.
 - b. All remediation work on any one level of the ATCT shall occur concurrently unless noted otherwise.
 - c. Remediation of gypsum board at the Cab Level door to the exterior walkway and of the sloped ceiling beneath the Cab sink shall not occur at the same time in order to maintain access to the Cab. Begin remediation of the second area after the first is finished. Restoration work may be performed in both locations at the same time provided access to the Cab is maintained. This work and work in the Cab shall be scheduled at the beginning of the project to avoid conflicts or overlap with a pending project to replace consoles in the Cab.
 - d. Remediation work in stairwells shall proceed from the top to bottom.
 - e. Remediation work in the elevator shaft shall occur only after remediation and removal of gypsum board is completed on all walls forming the exterior side of the elevator shaft. This will allow the FAA to conduct a visual inspection of the concealed side of the 1" shaft liner panels at these locations and determine if additional work will be required to remove and replace any sections of the shaft liner prior to work beginning in the elevator shaft.
 - f. All work in the ASDE Level, Control Cab, Cab stairwell, Junction Level, the connecting link between the Base Building and ATCT, 2TS1, 2TS5, and 1TS1 shall be performed at night between the hours of 10:00 PM and 6:00 AM. Cleaning work in the Subjunction Level shall also be performed during these hours. Remediation (removal of gypsum board) in SJ1 may be performed during regular hours.

- g. All work in the elevator shaft shall be performed at night between the hours of 9:00 PM to 11:30 PM, 12:00 AM to 3:30 AM, and 4:00 AM to 6:00 AM. The elevator shall be available for use by FAA personnel during the time periods between these shifts.

1.2 REMOVAL AND REMEDIATION. The floor plans and notes in the appendix identify areas where cleaning is required and provide the approximate areas or quantities of contaminated items to be removed during remediation on a room by room basis. The work is further defined in the SOW as well as this document (SSOW). All gypsum board with any visible signs of mold or microbiological contamination or that is water stained or damaged shall be removed and replaced. Gypsum board shall be removed to a minimum of 12" beyond any visible mold. The plans identify the walls by types A, A1, B, B1, and C. The sheet labeled "PARTITION TYPES" shows the thickness and number of layers of gypsum board on each type wall. For all fire rated walls with multiple layers of gypsum board, the joints between the surface layer and concealed layer shall be staggered by at least 6" horizontally unless noted otherwise and by at least one stud spacing vertically. The dimensions identified on the drawings are minimum removal dimensions and generally include the 12" beyond visible mold. Removal shall be to a vertical stud if one coincides with that location or to the next stud beyond the limits identified. A new stud and section of top runner shall be installed at locations where fixed equipment prevents removal to the next stud.

2.0 MATERIALS. The following specifications provide the minimum requirements for materials furnished and installed under this contract. The Contractor shall furnish submittals for all materials proposed to be used under this contract as indicated below. Alternate products that are equal to or exceed those listed below may be submitted for approval by the FAA. Materials shall be installed in accordance with the manufacturer's written recommendations and instructions. This section also provides additional information on the scope, quantity of work to be performed, or quantity of material to be installed. It also identifies specific installation requirements applicable to these materials.

1. Gypsum board – The majority of all walls included are fire rated walls unless otherwise noted. The thickness, configuration, and number of layers of gypsum board are identified in the appendix on the sheet titled "PARTITION TYPES". The floor plans identify the partition type with a circled letter designation corresponding to the applicable partition type.

All gypsum board utilized shall be a paperless gypsum board product designed for mold and moisture resistance. Gypsum panels shall consist of a moisture resistant, noncombustible gypsum core with glass mat facings on both the front and back of the panel. Water absorption shall be less than 5% by weight. Sheets shall be 5/8" thick, 4' wide, 8 – 12' long, with tapered edges. The flame spread shall not exceed 10 and the smoke developed rating shall not exceed 5 per ASTM E84. When tested in

accordance with ASTM D 3273, the product shall show no fungal growth and have a rating of 10. Utilize fiberglass mesh tape, gypsum setting type joint compound, 1-5/8" minimum sheet rock screws, etc. as recommended by the manufacturer to tape and finish the walls. All gypsum board shall be DensArmor Plus Fireguard as manufactured by G-P Gypsum Corporation or equal. For all walls in areas with existing painted walls, all joints shall be taped and filled flush. Tape and finish visible walls to provide a smooth finish matching existing without noticeable joints or transitions leaving wall surfaces ready for painting. For concealed areas such as above ceilings, gypsum board shall be fire taped only to meet the required rating of the wall assembly. Taping and finishing are not required on walls where the gypsum board is being installed as a thermal barrier over rigid insulation. Install in accordance with manufacturer's instructions and ASTM C840, Standard Specification for Application and Finishing of Gypsum Board. For fire rated installations, the installation and details, including fastener size and spacing, shall be in accordance with the applicable details in the Gypsum Association Fire Resistance Design Manual GA-600, and the UL Fire Resistance Directory. Gypsum board shall be held a minimum of 3/8" above the floor to minimize moisture damage. This void shall be sealed with the fire stop sealant specified below to provide the required rating of the wall assembly.

Shaft liner panels shall be composed of a water resistant, noncombustible gypsum core with a coated glass mat facing on the front and back of the panel. The flame spread shall not exceed 15 per ASTM E84. Panels shall show no fungal growth when tested in accordance with ASTM D 3273. Shaft liner panels shall be 1" thick, 24" wide, and 8 - 12' long. Panels shall have a 6 month exposure warranty. All shaft liner panels shall be DensGlass Ultra as manufactured by G-P Gypsum Corporation or equal. Install in accordance with the manufacturer's recommendations and instructions and in accordance with the applicable details in the Gypsum Association Fire Resistance Design Manual GA-600, and the UL Fire Resistance Directory. Stagger horizontal joints between adjacent panels by a minimum of 12".

2. Metal Framing – Wall framing components such as studs and track shall match existing in size, profile, and gage. Metal framing is required where access panels are being installed in existing walls or ceilings, where a header will be installed to support the overhead wall between 11TS5 and 11TS5A, and where existing fixed equipment prohibits removal and replacement of gypsum board to an existing stud location. Utilize a minimum of 20 gage material to frame openings for access panels and for headers. Construct the header of two boxed joists. Frame openings in accordance with manufacturer's standard details and recommendations and in accordance with the recommendations of the access panel manufacturer. The openings in fire rated walls shall be framed of

sufficient size to allow wrapping all of the metal framing components around the perimeter of the opening with gypsum board as shown on the standard detail for the access panel specified. Construct supports for the drip pan under the Cab sink using metal framing components attached to the existing framing supporting the sloped ceiling beneath the Cab sink cabinet. Additional metal framing shall be installed in walls at any location where existing fixed equipment makes it difficult or impossible to remove gypsum board to an existing stud. In this case, an additional section of a vertical metal stud and horizontal track shall be installed to provide a location to fasten both the new and existing gypsum board.

3. Access Panels – Access panels shall be of the size and type (non-rated or rated) as identified on the floor plans and notes in the appendix. The frame of non-rated panels shall have a 1" exposed flange for flush installation in any wall or ceiling and be a minimum of 16 gage cold rolled steel. Doors shall be a minimum of 14 gage cold rolled steel with concealed spring hinges capable of opening to 175 degrees and have a screwdriver operated cam latch. Access panels shall be finished with the manufacturer's standard prime coat finish. Non-rated access panels shall be Nystrom NT series or approved equal. Rated access panels shall be UL listed, B label, 1 ½ hours. The rated access panel assemblies with door, frame, hinge, and latch shall be provided by a manufacturer listed in the Underwriter's Laboratories Building Materials Directory for the rating indicated. Frame shall be 16 gage cold rolled steel with a 1" flange for flush installations. Doors shall be constructed of 20 gage cold rolled steel with a minimum fill of 2" thick fire rated mineral fiber insulation and shall have a continuous piano hinge. Doors shall have a knurled knob/key operated latch bolt. Access panels shall be finished with the manufacturer's standard prime coat finish. Rated panels shall have a spring to close the door. Rated access panels shall be Nystrom IT series or approved equal. Access panels shall be installed in accordance with the manufacturer's written instructions. Framing of the openings and installation of the access panels shall meet all the requirements for maintaining the fire rating of the wall or ceiling. Frames shall be installed plumb and level in the opening. The door shall easily close and latch and shall be flush and in a smooth plane with the frame when closed. Installed access panels shall be free of warps, bows, or physical damage.
4. Plumbing Materials – Waste and vent pipe fittings for modification of the existing Cab sink drain line shall be no-hub cast iron pipe in compliance with ASTM A 888. Size shall match existing. Drain line shall be reconfigured as indicated in the notes in the appendix to allow a drip pan to be installed under the clean out. Do not use power tools to cut existing pipe in the Cab. The dimensions given for the drip pan are the minimum size and the pan shall be maximized based on the space that can be created by relocating the drain line and cleanout. The drip pan shall be

constructed of a minimum of 16 gage galvanized steel with continuous welded seams to provide a leak-proof container. Fabricate a flat support of metal framing components on top of the sloped ceiling forming the base of the sink cabinet to support the drip pan. All plumbing work shall be performed by a licensed plumber.

5. **Electrical Materials** – The minimum conduit size for all power wiring is ¾" EMT with compression fittings. Wire size, type, and color coding shall match existing. All circuits shall have a separate neutral and ground conductor. Ground all electrical boxes. All work shall be in compliance with the National Electric Code and applicable FAA electrical specifications as indicated through the requirements above. Remove all conduit, wiring, and supports no longer being utilized. The work required is listed on the notes and drawings in the appendix and includes removal of a light switch, conduit, and wiring for room 11TS5A and rewiring the lights from the existing circuit and switch serving room 11TS5. It also includes constructing a frame and supporting an electric panel where the wall is being removed. All penetrations through rated walls shall be fire stopped. Any openings in rated walls resulting from the removal of existing conduit shall be fire stopped. All electrical work shall be performed by a licensed electrician.
6. **Support Strut** – All strut members shall be a minimum of 1 5/8" x 1 5/8" and have a galvanized finish. Utilize the manufacturer's standard fittings such as base plates and brackets to design and construct the rack to support the electric panel. The electric panel shall be bolted to the rack at four places, near each corner. The rack shall consist of two vertical legs and horizontal cross members. The rack shall bolt to the floor at each leg and to the header of the wall opening above. The submittal shall include a sketch of the rack identifying the components utilized. Materials shall be by B-Line, Unistrut, or approved equal. Temporary strut bracing shall be used to brace the raised access floor at any location where more than three raised floor panels and three perimeter pedestals and stringer connections are removed to access work areas (walls) on the Subjunction Level. Braces shall consist of a horizontal strut U-bolted to multiple pedestals and diagonally braced to the floor or structure with strut components at intervals not more than 3' on center. The temporary strut shall prevent lateral movement of the floor system when portions of the system have been removed. Remove temporary strut bracing after all access floor components have been reinstalled.
7. **Wall base** – Resilient wall base shall be a removable and reusable system that does not utilize adhesives. The base shall be .1" thick and 4 3/8" in height and shall have an integral tabs on the back that clip into a wall mounted rail. The system shall utilize preformed outside corners and field coped interior corners. Base profile shall have a standard cove base. If

this profile is no longer available, utilize the Tempo Profile with end stops and inside and outside corner stops. Base shall be a thermoplastic rubber formulation designed to meet the dimensional and performance requirements of ASTM F 1861, Type TP, Group 1. Resilient wall base system shall be Johnsonite rePLACE or approved equal. Color to be selected from standard colors and similar to existing. Base shall be installed in accordance with the manufacturer's recommendations and instructions. Remove all existing wall base in the Subjunction Level Equipment Room and install the wall base specified above. Install government furnished wall base where removed at the exterior door at the Cab Level. Furnish and install a section of cove base to match existing where removed from the north wall of 2TS5. Furnish adhesive for use at these locations with antimicrobial protection from mold, mildew, and bacteria. Cove base shall not be reinstalled at other locations throughout the ATCT shaft where it was removed.

8. Sealant – Sealant shall be a one part silicone and meet the following requirements: FS TT-S-00230C (Class A), ASTM C 920 (Type S, Grade NS, Class 50, Use NT, G, A, and O). Sealant shall be Dow Corning 795 Silicone Building Sealant or equal. Sealant shall be utilized to seal all penetrations in the handrail posts on the Junction Level walkways. Expanding foam or other approved backers shall be used to fill the top of the tubes prior to application of the sealant. This sealant shall be acceptable for applications where a specific sealant has not been specified. See item 16 for sealant for building openings at louvers.
9. Insulation – Insulation shall match the material type and thickness of any contaminated insulation being removed under this project. Utilize a vapor barrier to match existing where present.
10. Fire Safing Insulation – Safing insulation shall be a noncombustible mineral wool type insulation (per NFPA 220 when tested in accordance with ASTM E 136) that can resist temperatures to 2000 °F. Safing shall be moisture resistant, noncorrosive, nondeteriorating, and mildew-proof. Safing insulation shall be installed in the cavity between the 11th floor slab and the precast exterior walls to provide a smoke barrier where the existing contaminated material is being removed. Safing shall be installed with a compression fit to a minimum depth of 4". Safing shall be Thermafiber Safing Insulation or approved equal.
11. Firestop Material – Fire stop material utilized shall provide a fire and smoke barrier with up to a two hour rating. Installed fire stop materials shall be the components of a UL listed and tested assembly with rating equivalent to that of the wall assembly it is being installed in. Firestop material shall be Hilti FS-ONE high performance intumescent firestop

sealant, or equal. Install firestop material between the floor and the bottom of all wall materials installed on rated walls under this contract.

12. Paint – Paint shall be a low odor, two component water based catalyzed epoxy with manufacturer's recommended primer (low odor). Paint shall be B70 Series (part A) and B60 V 25 semi-gloss hardener (part B), as manufactured by Sherwin Williams or equal. Surfaces to be painted shall receive one coat of primer (new gypsum board and joint compound only) and two finish coats unless otherwise noted. Paint all replaced sections of wall exposed to view in the Subjunction Level Equipment Room to match existing. This includes the south wall from the SE corner adjacent to stairwell SJ5 to the SW corner of the room, the entire west wall, and the NW wall. Paint entire wall surface where gypsum board has been removed and replaced to nearest natural break line (corners). On the Cab Level, paint all replaced sections of wall exposed to view and walls where patching or taping occurred due to new gypsum board on adjacent surfaces. This includes the sloped ceiling section beneath the Cab sink, and all walls from the SW corner of the landing below the exterior door to the walkway up to the cab level. Apply two coats of a latex stain-blocking primer such as Kilz to the water stains on the ceiling of the Cab stair landing below the sloped ceiling section being replaced. Paint the entire landing ceiling. Paint all of the above areas to nearest natural break line such as a corner.

Contract Option 1 – Paint all access panels installed to match adjacent wall or ceiling color. This includes the visible portions of the frame and door that will be visible with the door closed. Painting includes prime coat and two finish coats.

Contract Option 2 – Repair the water damaged tape joint along the west wall of corridor 9TS1. Prime the water stained areas on the ceiling and walls with a latex stain blocking primer. Repaint the ceiling and the entire west and south walls of corridor 9TS1 with one finish coat to match existing colors. See 9th floor notes in the appendix for additional information.

13. Pipe Insulation – Insulation shall be fiberglass pre-formed pipe insulation with a factory applied, all service, vapor barrier jacket. Thickness shall match existing. Provide a continuous vapor barrier. Install insulation, sealant, and vapor barrier in accordance with the manufacturer's written instructions. Provide re-enterable insulation at fittings and valves that must be periodically accessed or maintained to allow for easy removal and reinstallation by maintenance technicians. Locations and approximate quantities are listed in the drawing notes in the appendix. Field verify all pipe sizes.

14. Detergent – The detergent used shall be an unscented household dish washing detergent. Mix with ten parts water. Furnish in unopened original containers and provide the MSDS. Detergent shall be Palmolive Dish Washing Liquid Regular Green or approved equal.
15. Temporary Walk Boards and Supports – Construct supports of 2x6 lumber in triangular shape for a compression fit in the void between the exterior face of the perimeter shaft wall (partition type B) and the sloped precast panels at the Subjunction Level. Secure ½” plywood to the side of each support to create a rigid assembly. Place supports at 2’ on center to coincide with the locations of the existing type C-H studs. Place 2” nominal thick lumber across the top of the supports, fastened by screw to each support, to create a walkway for visual inspection of the concealed side of the perimeter walls. Allow a 3” gap against the shaft liner panels to allow for a visual inspection of the gypsum board beneath the surface of the walk boards. Access will be through the new access panels to be installed. Remove upon completion of the inspection. The quantity provided shall be enough to inspect one perimeter wall and the shorter adjacent angled wall, such as the west and NW walls (approximately 36 LF). After the visual inspection of each area is complete, the walk boards and supports may be moved and reused at another location until all walls (west, NW, north, NE, and east) have been inspected. Remove all walk boards and supports after the inspection is complete. Provide temporary lighting and extension cords to illuminate the inspection areas to at least 40 foot-candles.
16. Louvers – Replacement of existing louvers shall be priced as contract options. Louver dimensions shown on the drawings are approximate. Field verify actual louver sizes, depth, and installation configuration. The 4th floor intake louver is approximately 4’ x 7’ as indicated on the drawings. The 3rd floor exhaust louver is slightly smaller than indicated on the drawings and is approximately 4’ x 4’-7”. Louvers shall be constructed of extruded aluminum alloy, 6063-T5 with a nominal thickness of .081”. Frame depth shall be 5”. Blades shall be sightproof, double drainable, with horizontal mounting and centered 2” on center. Louver shall be furnished with insect screen. Louvers shall have 44% free area, be wind driven rain penetration class A, and have a discharge loss class of 2. Wind driven water penetration performance shall be based on testing a 39” x 39” nominal unit per AMCA 500-L: 29MPH wind velocity, 3”/hr rainfall rate, 6027 CFM air volume, 588 FPM core velocity, 1139 FPM free area velocity, and a water resistance effectiveness of at least 99.3%. Finish shall be Kynar to match existing louver color. Louvers shall be Ruskin EME520DD Wind-Driven Rain Resistant Stationary Louver or approved equal. The existing louvers are 4” nominal thickness. The existing louver shall be removed and the existing sheet metal wall sleeve or plenum shall be modified to accommodate the new 5” nominal

thick louver. The existing sleeves terminate in a bent "L" shape leg against the back side of the louver. Modify the existing sleeve to create a similar installation or cut back the sleeve and install a continuous "L" shaped angle, matching the gage of the sleeve, around the perimeter of the opening. The gap between the sleeve and the precast concrete or the gaps between the precast and the sleeve and the sleeve and the L-shape angle shall be sealed prior to installing the louver. All existing sealant shall be removed and the surface cleaned and prepared for new sealant by grinding. The existing ground wires shall be fastened to the new louvers in the same manner as the existing. The bottom of the 3rd floor louver coincides with the counterflashing for the link roof. Ensure that the removal and replacement of the louver does not damage the counterflashing or compromise the watertight integrity of the roof and flashing. Perimeter sealant shall be installed in accordance with the sealant manufacturer's recommendations and instructions and shall match the existing in color. Sealant shall be a high performance, low modulus, neutral curing, non-staining, silicone sealant capable of use in dynamically moving building joints with a +/- 50% movement. Sealant shall conform to ASTM C 920, Type S or M, Grade NS, Class 25, and Use NT, M, A, and O. Sealant shall conform to Federal Specifications TT-S-00230 (Type II, Class A) and TT-S-001543 (Class A). Tear strength shall be ≥ 23 pli in accordance with ASTM D 624. Peel strength (aluminum, concrete) shall be ≥ 15 pli in accordance with ASTM C 794. Sealant shall be Tremco Spectrem 3 Silicone Sealant (color Buff) or approved equal. All sealant work shall be performed by a specialty waterproofing contractor and workers regularly engaged in building sealant work.

Contract option 3 shall include removal and replacement of the 4th floor outside air intake louver on the west side of the ATCT shaft in accordance with the specifications listed above.

Contract Option 4 shall include removal and replacement of the 3rd floor exhaust louver on the east side of the ATCT shaft in accordance with the specifications listed above.

17. Spray-on Insulation – The application of spray-on insulation shall be priced as Contract Option 5. Structural steel and other steel surfaces such as the roof deck in the ASDE Penthouse and Vestibule typically experience condensation and frosting during the winter months. Portions of the steel surfaces are not insulated and the rigid insulation is not continuous and has gaps that leave steel surfaces exposed. The ¼" steel plate roof deck and structural steel adjacent to the exterior insulated metal wall panels create pockets without insulation that are prone to condensation. Insulate steel surfaces to prevent condensation. Contract option 5 includes the following items:

1. Remove existing rigid insulation and the reinforced fiberglass panels used for a thermal barrier from the roof deck and structural steel beams.
2. Prepare structural steel and 1/4" steel plate roof deck to receive insulation per the insulation manufacturer's instructions and recommendations. Prime or seal surfaces if required to insure bonding and to prevent discoloration.
3. Protect all surfaces not specified to be insulated to prevent overspray of the insulation. Surfaces to be insulated are structural steel below the top of the ring beneath the ASDE antenna (shown as a curb on drawing S10) and the 1/4" steel plate roof deck. Items that shall be protected and not insulated include walls, floor, light fixtures, heater, electric panels, equipment, any covers of junction or pull boxes, covers of conduit bodies, ground connections to structural steel, color code tape markings of grounding cables, the ASDE antenna and supports, smoke detectors, ground plates, etc. Items such as beam clamps, struts, or conduits attached to steel beams may be insulated.
4. Fully insulate the pockets or voids around the exterior perimeter of the ASDE Penthouse and Vestibule formed between the exterior insulated metal wall panels, the adjacent steel beams, and the 1/4" steel plate roof deck. If it is not possible to spray these areas, other suitable insulation materials shall be used to fully insulate this cavity and the spray-on insulation shall be applied to the bottom of the beam, over the opening, and terminate against the insulated metal wall panels to prevent air infiltration in this space.
5. Spray-on insulation shall be applied to all structural steel below the elevation of the top of the steel ring immediately beneath the ASDE antenna and to all surfaces of the 1/4" steel plate roof deck.
6. Clean up the site to remove all tarps and temporary coverings, over spray, insulation materials, debris, dust, etc. from all surfaces not scheduled to be insulated.

Provide certification that spray-on insulation contains no asbestos. The applicator shall be licensed by the insulation manufacturer to apply the product. Spray-on insulation shall provide an R value of 13. Insulation at the bottom flange of beams on the interior side may be tapered to 1" thick to leave the ground cables visible. Product shall be a sprayed-on cellulose thermal insulation. The cellulose fibers shall be chemically treated for resistance to fire, mold, and mildew. Insulation shall have a field tested bond strength at greater than 5 years of not less than 400 PSF and not less than 600 times its weight at 1" in compliance with ASTM E 736. Product shall comply with ASTM E 84/UL 723, tested at a minimum of 5" thickness Class 1, Class A: flame spread and smoke development not to exceed 5. The product utilized shall provide a class A finish without the need for a separate thermal barrier. Insulation shall be non-corrosive per UMB-80. Insulation shall be cured with mechanical ventilation. Dehumidifiers shall be utilized if required to prevent moisture accumulation on the floor. Insulation shall

be K-13 Spray-On-Systems by International Cellulose Corporation or approved equal. The insulation shall be sprayed with a water based vinyl acrylic emulsion coating containing interlacing/bridging fibers forming a protective coating over the fibrous surface. The coating shall provide additional protection from physical damage, protection from airborne contaminants, provide an easy to clean surface, increase light reflectivity, and have a Class 1, Class A flame spread of 5 or less. The coating shall be a heavy build coating with 99% coverage and shall be white in color. The coating shall be ProteK-13, or approved equal. This is intended to be a performance-based specification. Alternate systems may be submitted provided that the applied insulation has a Class A finish and does not require a separate thermal barrier.

- 3.0 SUBMITTALS.** The Contractor shall furnish submittals to the FAA for all materials proposed to be used or incorporated into the work under this contract. Furnish a minimum of three copies of submittals, one copy will be returned to the Contractor after FAA review. Include manufacturer's standard product and data sheets, catalogues, performance data, installation instructions and recommendations, test data, evidence of compliance, etc. Include MSDS sheets for products used under this contract. The Contractor shall maintain a set of MSDS sheets on site throughout the performance of work under this contract. Include plans for execution of work, establishment of work barriers, methods utilized to perform work, exhaust air system and calculations, and removal and disposal of materials.
- 3.1 PROJECT SCHEDULE.** The Contractor shall furnish a detailed schedule for FAA approval that shows a breakdown of all remediation and restoration activities on a room by room basis. The schedule shall show all work being performed concurrently or performed under the constraints identified in the Work Summary (1.0) and the Schedule and Sequence Requirements (1.1) sections of the Supplemental Statement of Work. The schedule shall show the duration of all activities and the time required to complete them in number of days. All remediation and restoration work in each phase, area, or room shall be completed as soon as possible to avoid disruption to facility operations. For example, any restoration work identified should begin as soon as remediation is completed and the area cleared and all furnishings shall be returned to their original location once remediation and restoration work is complete, etc. As a minimum, the follow on activity should begin the next work day after the preceding schedule activity is completed. The schedule shall be submitted and approved prior to the Contractor beginning any work on site. The schedule shall be revised and updated as necessary during the project to keep it accurate.
- 4.0 EXECUTION/INSTALLATION.** The Contractor shall perform work in accordance with any constraints and sequence requirements identified, the approved project schedule, and as coordinated with the FAA. The Contractor shall meet with the FAA COTR or designated person on a daily basis to discuss and review the work proposed for that day and the next day and review any

special procedures, constraints, impacts to the facility, or schedule requirements involved with completing the work. The Contractor shall schedule and plan all work so that normal facility operations may continue with a minimum of disruptions or interference and all work is completed within the contract time and specific durations identified herein. The Contractor shall be on site to accept all deliveries. Materials shall be brought on site and into the facility as needed for installation that day or stored in trailers or containers located in designated parking areas. The Contractor shall protect all materials from damage and keep them in a like new condition. The Contractor shall protect the existing building, grounds, furnishings, equipment, cables, etc. from damage and shall be responsible for the repair or replacement of any items damaged during the course of the work. The Contractor is responsible for moving FAA furnishings and property out of the work areas to designated storage areas or for cleaning them and wrapping them in plastic per the SOW if they remain in the work area during remediation. The Contractor is responsible for moving these items back to their original location after the completion of work in that area. Damage to operational equipment or cabling will be repaired or replaced by the FAA based on requirements to meet the FAA's mission. The FAA may, at its option, direct the Contractor to make specific repairs or purchase specific replacement material or equipment as deemed necessary to maintain the equipment and facility in accordance with FAA orders, procedures, and directives. In any case, the Contractor shall pay for the cost of repairs or replacement for any items damaged by their work under this contract. The Contractor shall maintain the job site in a neat and orderly condition. This includes prompt and daily removal of any rubbish, debris, tools, equipment, or materials not required for the work in progress. Contractor parking will be designated in remote areas of the parking lot. The Contractor shall provide portable chemical toilets for use by all personnel performing work on this project. Toilet facilities shall be maintained in a sanitary condition.

The Contractor shall perform the work detailed and quantified in the SOW and SSOW. Work shall be completed in a neat and first class workmanship manner in accordance with manufacturer's recommendations and instructions for each item of work included in this contract and as specified.

The FAA will relocate the existing equipment racks adjacent to the west wall of Equipment Room SJ1 prior to the start of work to allow for remediation and restoration work to occur. A minimum of 12 inches of clearance will be provided between the racks and the face of the wall. It is anticipated that between 18 and 24 inches of clearance will be provided.

- 4.1 DEMOLITION/REMEDICATION.** Establish barriers and negative pressure enclosures and prepare each area for remediation as required in the SOW and SSOW. Perform all remediation work indicated. Promptly notify the FAA if additional mold is found beyond the limits identified. The Contractor shall carefully execute demolition work to protect and avoid damage to all portions or

components of the building not scheduled to be removed. Execute demolition by methods that will prevent damage to other work and will provide proper surfaces to receive installation or repairs. Set the depth of cutting tools to less than the thickness of the layer being cut to avoid damage to the portions of the concealed layer below to remain. Remove gypsum board by exposing fasteners and removing them to avoid damage to metal studs and framing components. Conduct demolition work to minimize noise and prevent the spread of dust. Utilize HEPA vacuums at the point of cutting to collect dust during cutting and removal of materials or use tools with shrouds or boots connected to a HEPA vacuum. Clean up debris promptly upon removal. Items shown to be removed and not reused shall be disposed as microbiological contaminated material per the Statement of Work. Any items shown to be reused shall be cleaned, decontaminated, salvaged, and reused.

- 4.2 BARRIERS.** Barriers shall be utilized to isolate the remediation and restoration work from occupied or in-use portions of the facility where physical barriers such as walls do not exist. Barriers shall be utilized to isolate all remediation areas from occupied or in use areas during each phase of the work. A barrier is not required for removal of the Cab stair ceiling below the Cab sink. Specific requirements for the performance of work in this and other areas are included in the SOW. Barriers shall be constructed of wood or metal studs placed 24" on center. Install a compressible material such as foam between the top plate of the wall and the ceiling. Barrier walls shall be covered with two layers of 6 mil polyethylene per the Statement of Work. The method of attachment shall be inconspicuous or non-damaging to ceilings and walls. A quick to assemble or easily reusable system that allows for height adjustments is recommended. The mini-enclosure at the exterior door in the Cab stairway shall not block more than half of the landing in order to allow personnel to access and exit the Cab.
- 4.3 EXHAUST.** The HEPA ventilation system shall exhaust air to the exterior of the building where possible to maintain work areas under negative pressure in accordance with the Statement of Work. Exhaust air shall be ducted in flexible duct with wire reinforcement to maintain its shape and intended cross sectional area. A negative pressure mini-enclosure for work at the Cab Level door shall be created utilizing a HEPA vacuum located on the Cab Level walkway. This enclosure shall not block more than half of the width of the landing in order to maintain access to the Control Cab. If necessary to meet the design requirements at any location, install a second negative air machine in line or in series with the units in the work area to ensure that the sufficient exhaust air is ducted to the point of discharge to maintain the specified pressure differential between work areas and occupied areas of the facility. Ensure that sufficient make up air is provided. In locations where it is not practical or possible to exhaust to the building exterior, the discharge air shall pass through a second HEPA filter. All negative pressure enclosures shall maintain a minimum pressure differential of .02 inches of water and have at least four air changes per hour. Negative air machines shall be rated for 80% of the listed capacity. Provide detailed

information on the exhaust system along with calculations showing that the required number of air changes will be obtained in the project submittals. See additional requirements in the Statement of Work. The Contractor shall utilize a combination sensing alarm and recording type pressure differential monitor to verify that all containments meet the minimum negative pressure requirement relative to adjacent occupied or non-work areas in the building.

- 4.4 RESTORATION.** Upon completion of all demolition and remediation work identified herein and in the Statement of Work, the Contractor shall restore the facility as specified and place all furnishings, equipment, etc. temporarily relocated back in place. Restoration includes installation of replacement materials such as insulation, gypsum board (including taping and finishing, except where excluded), insulation, wall base (where specified), painting (where specified), final clean up, etc. Taping and finishing on walls shall produce a finished surface ready to be painted. Fire taping is permitted only in concealed locations such as above ceilings. All surfaces, finishes, components, items, etc. disturbed or removed as a result of the work required under this contract shall be restored to match the existing typical conditions for similar elements of the facility. Section 2.0, MATERIALS, identifies specific replacement materials that shall be utilized in lieu of the existing materials being removed and replaced and provides additional restoration requirements. All work areas shall be thoroughly cleaned upon completion of work in each area or room. Remove all grease, mastic, adhesive, dust, dirt, stains, fingerprints, labels, other foreign materials, etc. from new or existing surfaces resulting from the performance of work included in this contract. Remove all debris from demolition or installation of new work. All new construction shall appear to be new and undamaged and free of grease, dirt, marks, blemishes, scratches, etc. Existing construction shall remain in a condition equal to or better than that which existed prior to the start of the project.
- 4.5 SEWER CLEANING.** Sewer lines serving the Control Cab sink and the floor drain (FD-3) serving humidifier H-1 in the SW corner of room SJ1 shall be cleaned by rotary cleaning with a full size auger type drain cleaner. Drain lines shall be cleaned to the length or extent described below. Remove the trap beneath floor drain FD-3 located in the outer ring on the 11th floor. Clean the trap and verify it is fully open and reinstall. This drain line shall be cleaned from the floor drain, through all 2" sections of waste piping and through all the 3" waste piping it connects to up to the riser at the pipe chase east of the elevator shaft. Clean the 1 1/2" drain line from the Cab sink to the point of connection with the 2" drain at the Subjunction Level. Utilize precautions such as plastic sheeting to protect walls and finished surfaces from dirt and water. Clean up all water and debris resulting from the cleaning of sewer lines. Cleaning of the section of drain line from the Control Cab to the Cable Access Level shall be performed at night.
- 4.6 EMERGENCY VENTILATION.** The Contractor shall keep a sufficient quantity of portable fans capable of providing ventilation and sufficient quantities of fresh air in the event occupied areas of the facility such as the Control Cab

experience high or unacceptable levels of odor during the performance of work. Include details of equipment to be provided in the submittal package. Show that fans are capable of ventilating the Control Cab or TRACON (room 203).

- 4.7 SPRAY-ON INSULATION.** All preparation work for the application of the spray on insulation below the bottom of the structural steel ring beneath the ASDE antenna may take place with the ASDE functioning. The exterior door may not be opened while the ASDE is operational. Preparation work includes removal of existing insulation and thermal barrier and covering/protecting items and surfaces from overspray. Protection of the ASDE antenna and ground connections on the steel ring shall be performed immediately before the application of the insulation when the ASDE equipment has been taken out of service. All work shall be conducted at night during the hours previously listed for night work. The Contractor will be permitted to use Room J8 on the Junction Level to set up mixing equipment and pumps. Cover all surfaces of the room to protect the finishes from damage. The hose shall be routed out the door to the microwave balcony, onto the walkway, and up to the Penthouse door at an existing Cab window mullion to avoid restricting vision from the Cab. The ASDE will only be shut down in periods of good weather. Pending rains or thunderstorms will result in cancellation of the shutdown and postpone the work to a clear day. A maximum of one 9 hour shut down will be provided for the application of the insulation and a second 9 hour maximum shut down will be provided for the application of the protective coating. Clean up all areas used in the performance of this work and application of the insulation and restore them to their original condition.
- 4.8 UTILIZATION OF ELEVATOR CAR.** The Contractor shall contract with the existing elevator maintenance contractor (Kone Elevator 816-531-2140) to provide the following services in support of any work performed in the elevator shaft. Work in the elevator shaft (cleaning shaft liner panels) shall be performed off of the top of the elevator car. The elevator maintenance contractor shall fabricate and install a temporary work platform on support members of the elevator car to provide a flat work surface, minimize trip hazards, and to prevent damage to the elevator car or equipment during the performance of work in the elevator shaft. The elevator maintenance contractor shall construct and attach the platform to the car to prevent damage to the elevator car and to provide a safe working environment and provide safeguards from any moving parts for the remediation contractor's personnel working on the car. The elevator maintenance contractor's recommendation for the maximum number of persons working on top of the car or for the maximum weight shall be followed. The elevator maintenance contractor shall be on site at all times the Contractor is working in the elevator shaft and shall take the elevator out of service and place it in manual control from the car top, operate the car, and return it to regular service for FAA use at the times designated in section 1.1. The elevator maintenance contractor shall perform all tasks such as positioning the elevator car, opening elevator doors for personnel to access the top of the elevator car, to lock out the car to clean the

bottom of the shaft, for any temporary modification of controls, etc. The car shall be positioned at 5' maximum intervals from the top of the shaft down for cleaning operations.

4.9 CLEANING TECHNIQUES. Utilize brush type attachments and crevice tools with HEPA vacuums to remove dust and dirt from all surfaces being cleaned. HEPA vacuum all walls of the elevator shaft prior to cleaning. All walls and surfaces indicated to be cleaned shall be cleaned with a detergent solution. Utilize sponges and rags to apply the solution and scrub the surface. Scrub brushes may be used on the steel stair stringers. Preclean the contaminated area in the elevator shaft below the 9th floor twice before cleaning the entire shaft. In the elevator shaft, the detergent solution shall be applied with sponges or sponge mops and the surface scrubbed to remove dirt and contaminants. Do not spray the detergent solution or water on walls. Do not use wire or stiff brushes, scouring pads, or other aggressive methods that will remove the face paper. Clean the walls in 5' maximum increments and reposition the elevator car to clean the next 5' section. Mark each 5' increment on a metal stud on each wall with a permanent marker.

5.0 FACILITY DRAWINGS. Reduced copies of the floor plan are included in the appendix for each level of the ATCT where work is required. The drawings are annotated with hexagon notes referencing specific work to be performed. Floor plans of the connecting link between the ATCT and Base Building are not included. Field verify the quantity of HVAC diffusers and grilles to be cleaned. The following facility drawings are provided as reference drawings to provide the Contractor additional information about the facility or conditions under which work must be performed. These drawings are for reference only and do not depict work to be performed under this contract. They are provided to show the facility layout and to assist in clarifying the work required. The drawings provided have been reduced to fit in this document and are not intended to be scaled from. A list of reference drawings is included below and pertinent information for each drawing is annotated.

CE-E-7893-A5: This drawing is included to show the exterior elevations of the ATCT tower shaft and the names and elevations of the different floor levels. It also identifies the location of the two exterior louvers identified for replacement in Contract Options 3 and 4.

CE-E-7893-A6: This drawing is included to show building sections 1 and 2 at the top of the tower shaft. See floor plans in the appendix for the location of the section cuts. The sections show the layout and configuration of the Cab stairs and tower shaft stairs that will be cleaned as part of the project. The ASDE Penthouse above the Control Cab is shown as well as the pull down-stairs that provide access to this level. The space between the perimeter shaft walls and precast concrete at the Subjunction Level where the temporary walk boards will be installed can be seen.

CE-E-7893-A8: This drawing is included to show sections 4 and 5 depicting the space where the temporary walk boards will be installed. See the floor plans in the appendix for the location of the section cuts.

CE-E-7893-A9: This drawing is included to show a section through the Control Cab and a larger view of the ASDE Penthouse and pull-down stairs that provide access from the Control Cab to the ASDE Vestibule and Penthouse.

CE-E-7893-A13: This drawing is included to show section 1 providing a more detailed view of the pull-down stairs and fixed ladder providing access to this area. The door shown next to the exhaust fan opening has an alarm and interlock that will shut down the ASDE equipment when opened. The Contractor shall not open this door. The door may only be opened for the application of spray-on insulation (Contract Option 5) at times when the ASDE equipment has been taken out of service.

CE-E-7893-A14: This drawing is included to show section cuts through the lower portions of the tower shaft stairwell and elevator shaft where cleaning work will be performed. Details of items to be cleaned such as handrails and stringers are shown.

CE-E-7893-A17: This drawing is included to show the reflected ceiling plans for the Junction Level and the Subjunction Level. These plans show typical locations of ceiling mounted speakers and HVAC diffusers, registers, and grills that will be cleaned as part of this project. Verify quantity on these levels as well as those on the 2nd and Ground Floor Levels of the ATCT and both levels of the connecting link.

CE-E-7893-M2: This drawing is included to show the approximate location and routing of sanitary sewer lines and clean outs that will be augered/cleaned out as part of the work under this contract. Field verify routing and clean out locations.

CE-E-7893-M3: This drawing is included to show the approximate location and routing of sanitary sewer lines and clean outs that will be augered/cleaned out as part of the work under this contract. Field verify routing and clean out locations.

CE-E-7893-M6: This drawing is included to show the duct for smoke relief between the elevator shaft and Cab Level walkway that will be used to exhaust air from the elevator shaft during cleaning.

CE-E-7893-M7: This drawing is included for reference to show the waste and vent riser diagram. This shows the approximate configuration of the sanitary sewer (drain) lines to be augered/cleaned out.

CE-E-7893-S10: This drawing is included for the Penthouse Roof Framing Plan that shows the configuration and sizes of the structural steel framing forming the

roof of the ASDE Penthouse and Vestibule. The application of insulation begins at the top of the ring identified in the Curb Framing Plan, detail 19.

6.0 PHOTOS. The following photographs and descriptions are included to provide additional details of the existing site conditions. Photographs are included for areas that have limited access due to facility operations or for areas that may be difficult to visualize based on the description of work required.

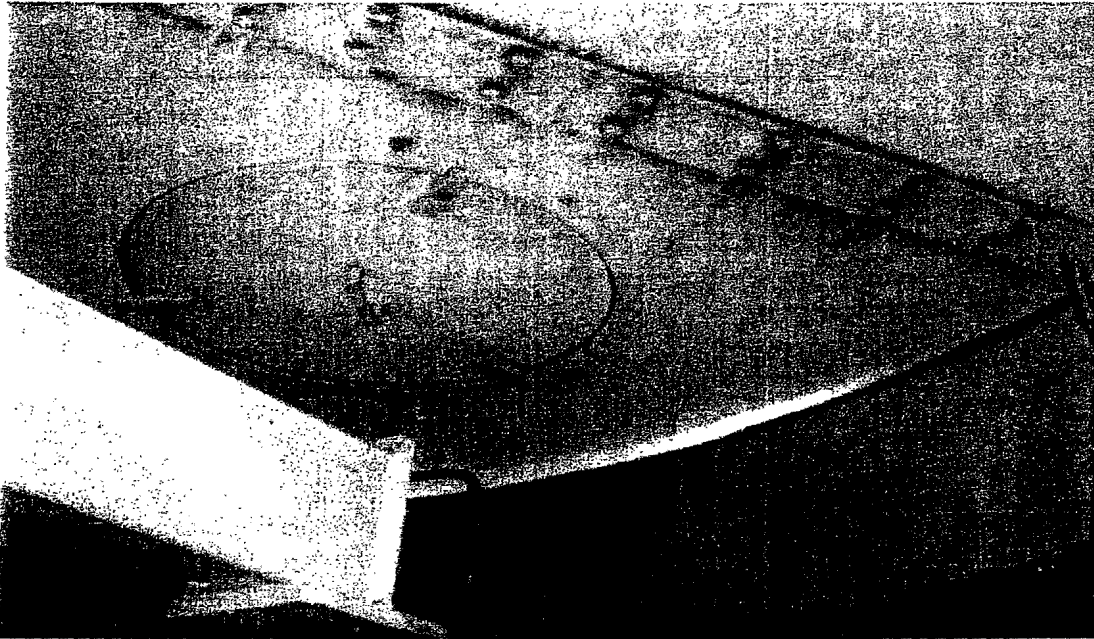

This photo shows the structural steel ring or curb beneath the ASDE antenna. The application of spray-on insulation (Contract Option 5) begins at the top of the ring and covers all structural steel below as well as the 1/4" steel plate roof. A ground cable is seen at the base of the ring.

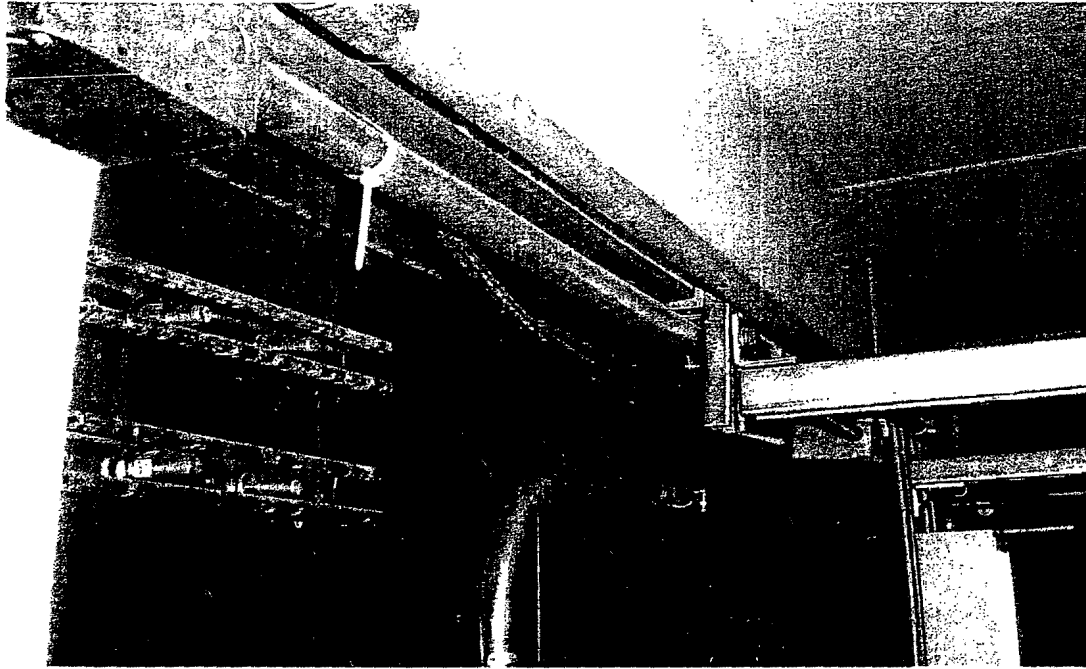

This photograph shows a typical beam at the perimeter wall insulated on one side. Junction box covers shall remain accessible after application of the insulation. Typical beam clamps and hangers can be seen.

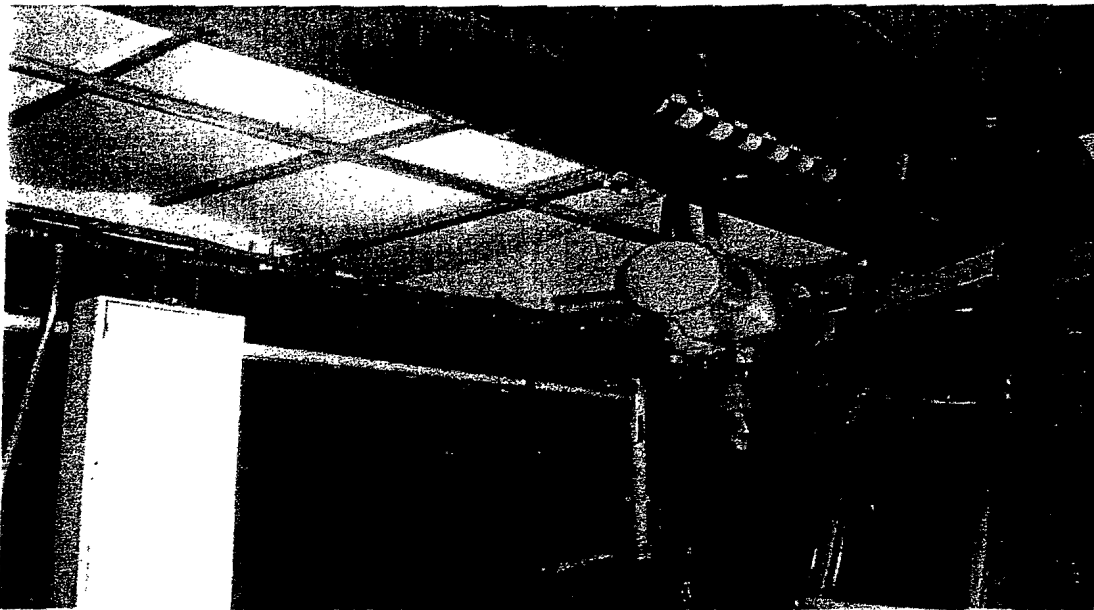

This photo shows the insulated roof deck with the fiberglass panels (thermal barrier) coming loose at many locations. Items to be protected from overspray such as a light fixture, conduit body cover, and heater can be seen in the background.

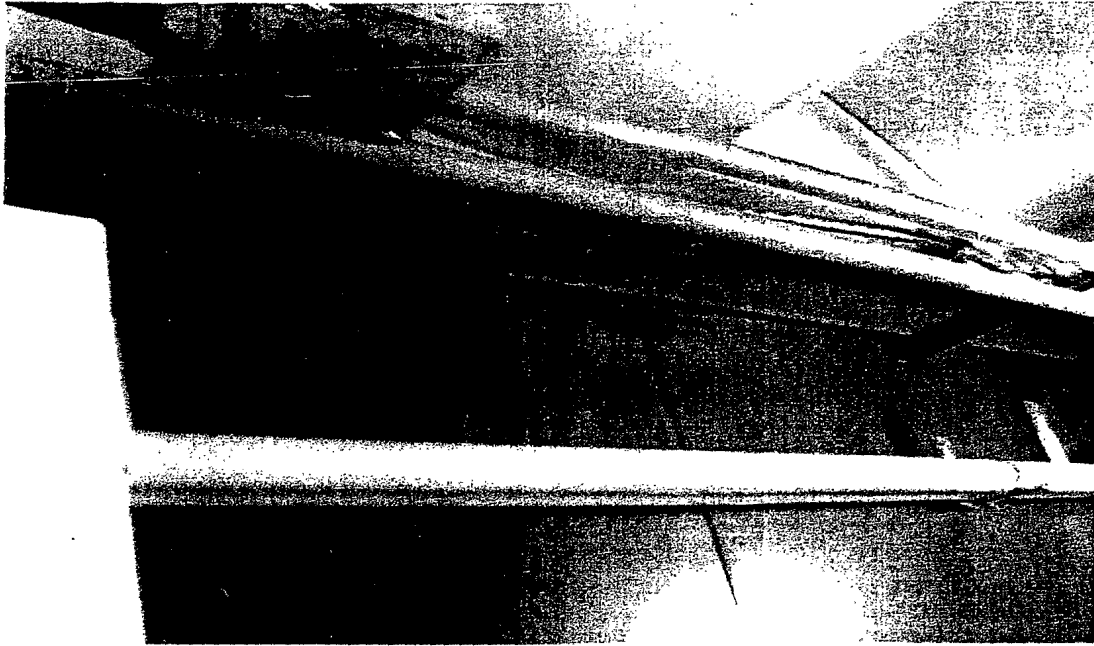

This photo shows the uninsulated pocket formed between the beam, insulated metal siding panel and the steel plate roof deck.



This photo shows the drain line under the Cab sink. The cast iron drain line section shall be removed and cut shorter allowing the cleanout to move to the right creating more space beneath it for a drip pan. The horizontal section of the drain line may also be moved up. A new drain line will be installed from this point to the sink.



This photo shows the pigeon droppings and fire proofing to be HEPA vacuumed in one of the Subjunction Level air shafts. An angle will be installed behind the drain as a water stop to prevent water entry into the building at the column. The vertical drain line may have to be cut shorter in order to install the angle.



This photo shows the east wall of room 11TS5. The strut support will be temporarily removed to remove and replace gypsum board. The door and a section of wall will be removed and a header installed to support the wall above since an electric panel in the corner of room 11TS5A will prevent replacing the wall. The new gypsum board will terminate at the NW corner of the elevator shaft. A strut rack shall be installed between the floor and header where the wall is being removed.

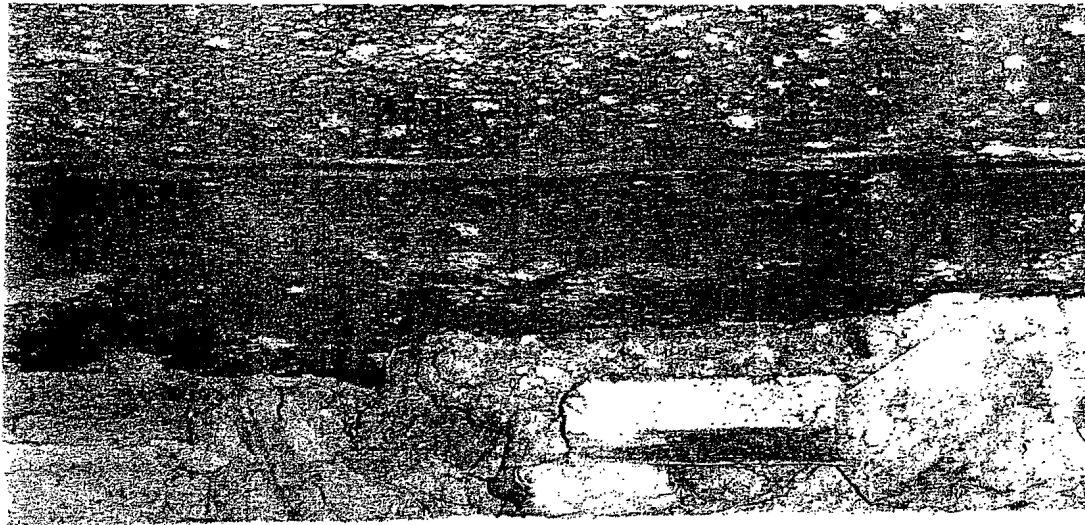

This photo shows debris and fire safing insulation in the void between the floor slab and precast panels in the 11th Floor Outer Ring. This condition is typical where gypsum board partitions are not adjacent to the exterior precast.



This photo shows debris and fire safing insulation in the void between the floor slab and precast panels in the 11th Floor Outer Ring. This condition is typical where gypsum board partitions are adjacent to the exterior precast.

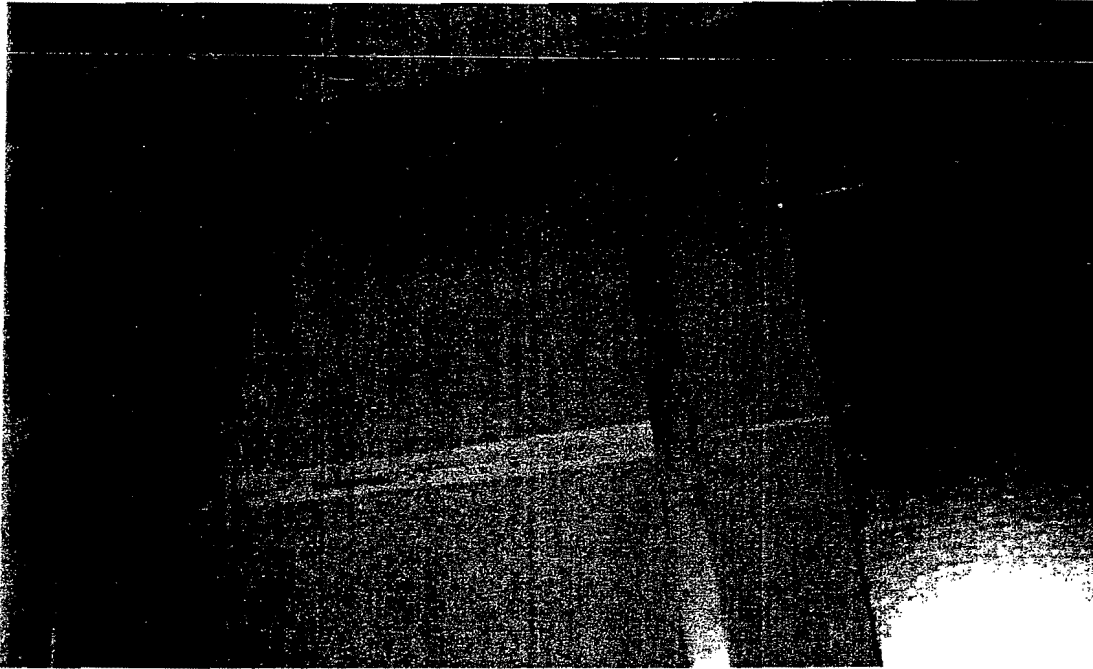

This is a typical photo of the shaft liner panels in the elevator shaft.

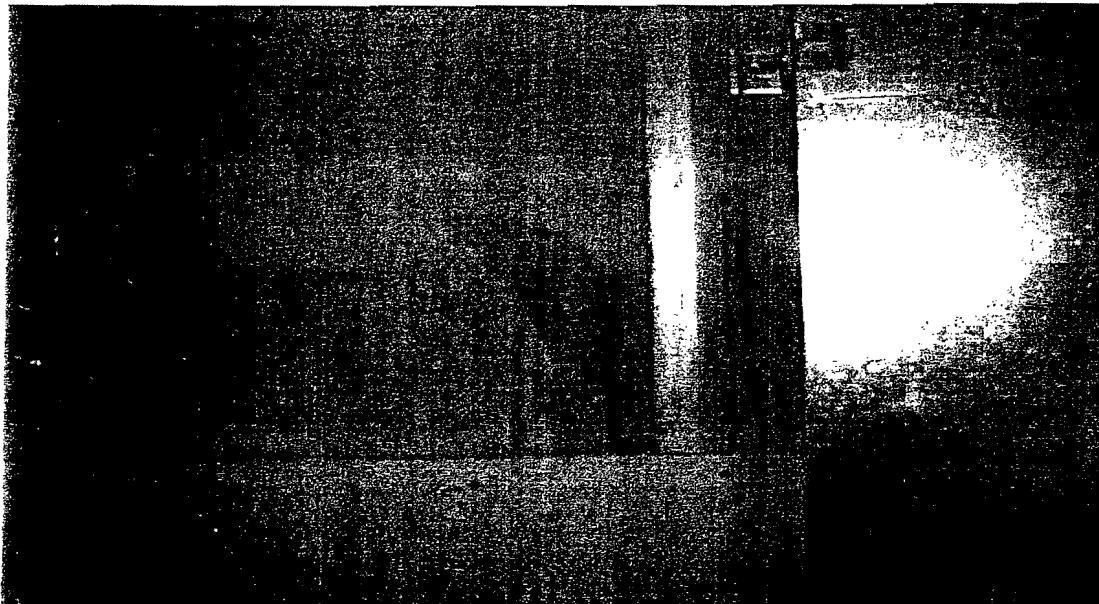

This photo shows a small band of mold on the north wall of the elevator shaft approximately ten feet below the ninth floor. This area and the adjacent contaminated panels shall be precleaned prior to cleaning the entire elevator shaft.

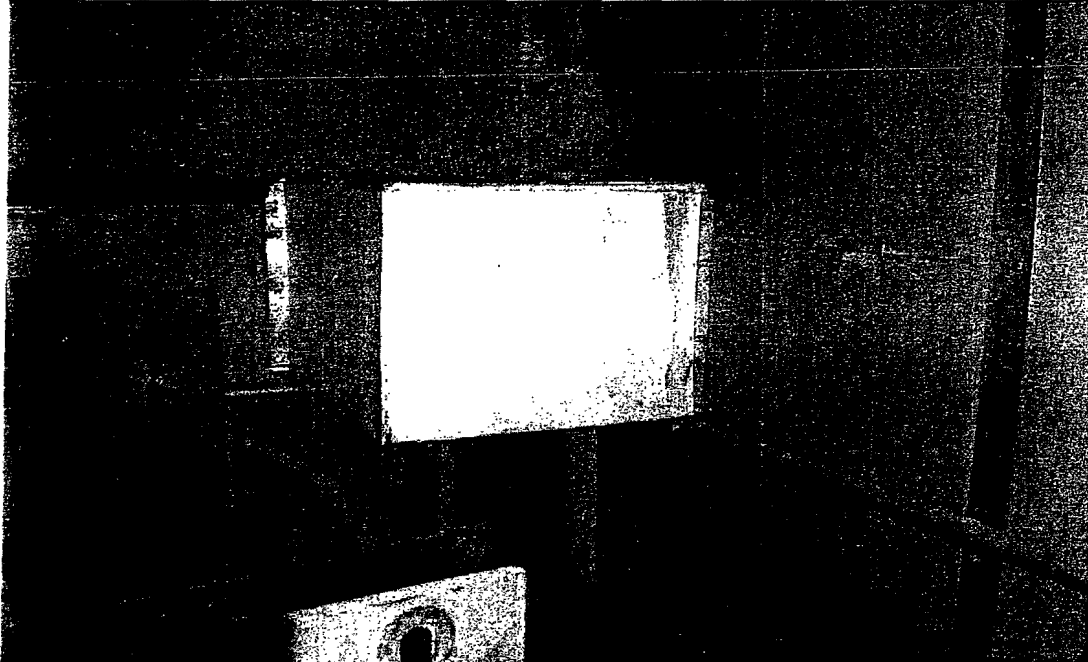

This photo shows the duct for smoke relief at the top of the elevator shaft. This duct shall be used to exhaust air to the building exterior and create a negative pressure containment during cleaning procedures in the elevator shaft.

APPENDIX

PARTITION TYPES

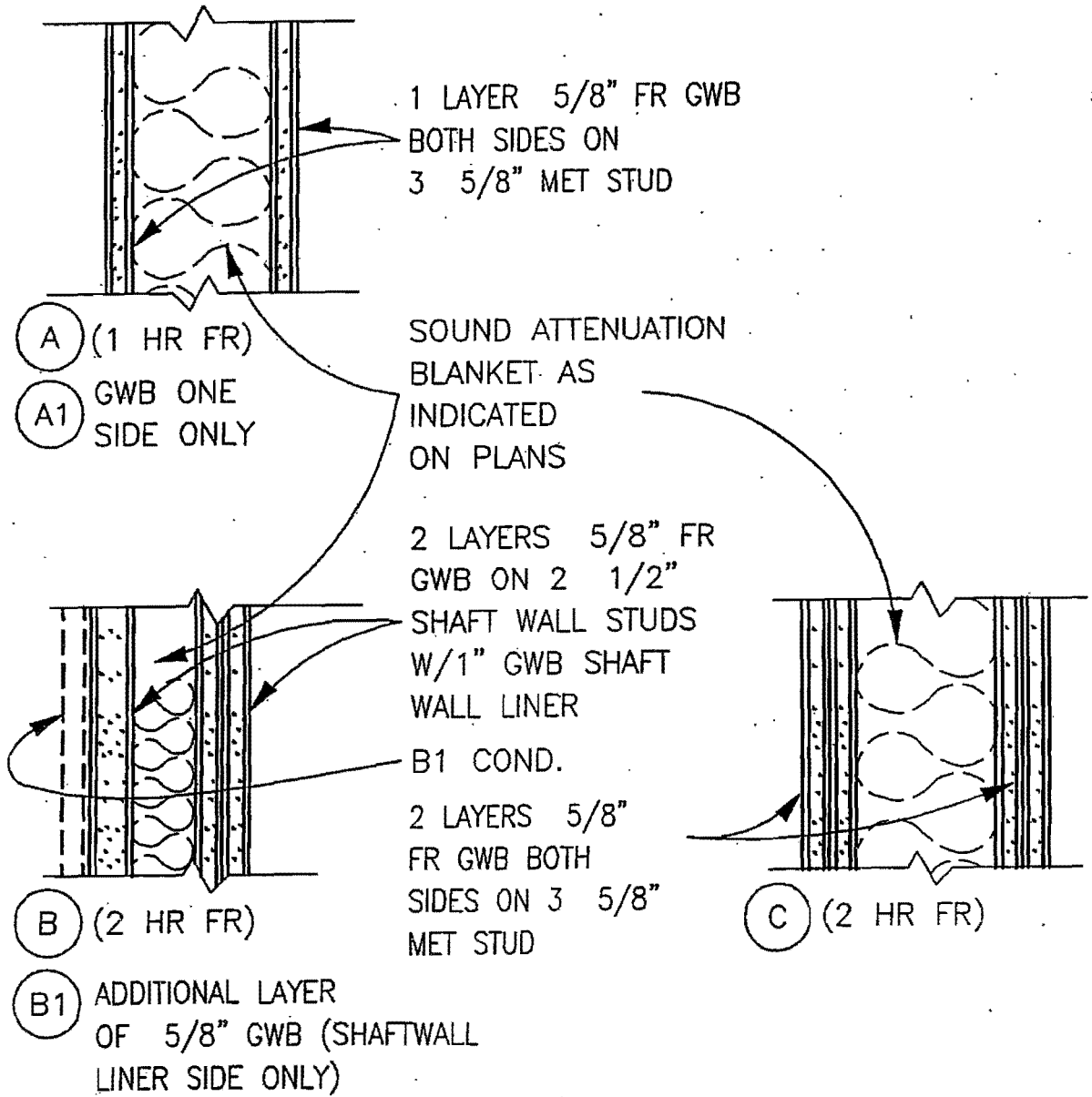

ASDE PENTHOUSE LEVEL NOTES

- 1 Wet wipe all insulated metal panel walls in the ASDE Penthouse and the ASDE Vestibule to remove water marks and stains.
- 2 Scrub and clean floor tile in the ASDE Vestibule and the ASDE Penthouse to remove white water marks and stains.
- 3 Contract Option 5: Remove existing rigid insulation and fiberglass reinforced panels used as a thermal barrier from structural steel and the roof deck in the ASDE Penthouse and Vestibule. Protect surfaces not to be insulated and apply a spray-on insulation system to the structural steel and roof deck below the elevation of the top of the steel ring or curb beneath the ASDE antenna as specified.

CAB LEVEL NOTES

- 1 The location shown for door C2 is incorrect. It is located on the landing and the east edge of the frame aligns with the east wall of the cab stairs. Remove vinyl cove base to the first joint beyond the remediation limits shown. Starting at the east side of the door frame, remove a minimum of 2 linear feet (LF) of gypsum board to a height of 18" above floor finish (AFF). Remove any water damaged or contaminated insulation. Complete remediation work as specified. Replace any insulation removed and install new gypsum board. Prime new gypsum board. Paint entire wall. Install Government furnished cove base where removed.
- 2 Remove vinyl cove base to the first joint beyond the remediation limits shown. Starting at the west side of the door frame, remove approximately 1 LF of gypsum board between the door frame and the corner bead to a height of 18" AFF. Remove any water damaged or contaminated insulation. Complete remediation work as specified. Replace any insulation removed and install new gypsum board. Prime new gypsum board. Paint all walls in the door recess. Install Government furnished cove base where removed.
- 3 Remove the water stained and contaminated gypsum board ceiling over the Cab stairs below the landing at door C2. This section of gypsum board is located beneath the Cab sink and is approximately 3'-2" x 7'-2". Minimize damage to adjacent gypsum board to remain. Remove in as large of sections as possible to minimize dust and to avoid cutting through any stained or contaminated areas. Install new gypsum board. Prime and paint the gypsum board ceiling. Apply two coats of stain blocking primer to the water stains on the ceiling above the landing immediately below this section and paint the ceiling above the landing with one finish coat. Paint all walls from the SW corner of this landing up to the Control Cab.
- 4 Modify existing drain line and cleanout to raise it further above the gypsum board and install a drip pan beneath the cleanout plug. The cleanout may be raised or shifted to the west to increase the clearance between it and the gypsum board below. The drip pan shall be fabricated of 16 gage galvanized steel and have minimum dimensions of 12" x 30" x 1.5" deep. Install metal studs or sheet metal supports to create a flat spot on the sloped ceiling framing to support the bottom of the pan. Modify/replace the drain line between the sink and vent and connect it to the relocated drain line.
- 5 Clean the entire stairwell as described in the Statement of Work. HEPA vacuum to remove all visible dust on surfaces such as stair stringers, gypsum board caps, ledges, pipes, conduits, etc. Wet wipe all surfaces in the stairwell. See the Statement of Work. Locate the HEPA vacuum remotely from the Control Cab and utilize longer hoses to reach work areas or insulate the vacuum to reduce noise to an acceptable level for facility operations.

- 6 HEPA vacuum and wet wipe all supply and return air grilles, registers, diffusers, etc. See the Statement of Work. Locate the HEPA vacuum remotely from the Control Cab and utilize longer hoses to reach work areas or insulate the vacuum to reduce noise to an acceptable level for facility operations.

CABLE ACCESS LEVEL NOTES

- 1 Remove and replace approximately 9 LF of water stained pipe insulation at the roof drain indicated. Test piping for leaks by utilizing a garden hose and the hose bib on the Cab Level walkway to flood the area around the drain and check for leaks. Water test for 15 minutes.
- 2 Clean the entire stairwell as described in the Statement of Work. HEPA vacuum to remove all visible dust on surfaces such as stair stringers, gypsum board caps, ledges, pipes, conduits, window framing, etc. Wet wipe all surfaces in the stairwell. See the Statement of Work.
- 3 HEPA vacuum and wet wipe all supply and return air grilles, registers, diffusers, etc. See the Statement of Work. This includes the return air grille on the wall of the Cab stairwell at the landing below the door to the Cable Access Level. Remove the return grille from the wall and clean from both sides.
- 4 Clean all gypsum board walls in the entire elevator shaft per the Statement of Work.

CABLE ACCESS LEVEL

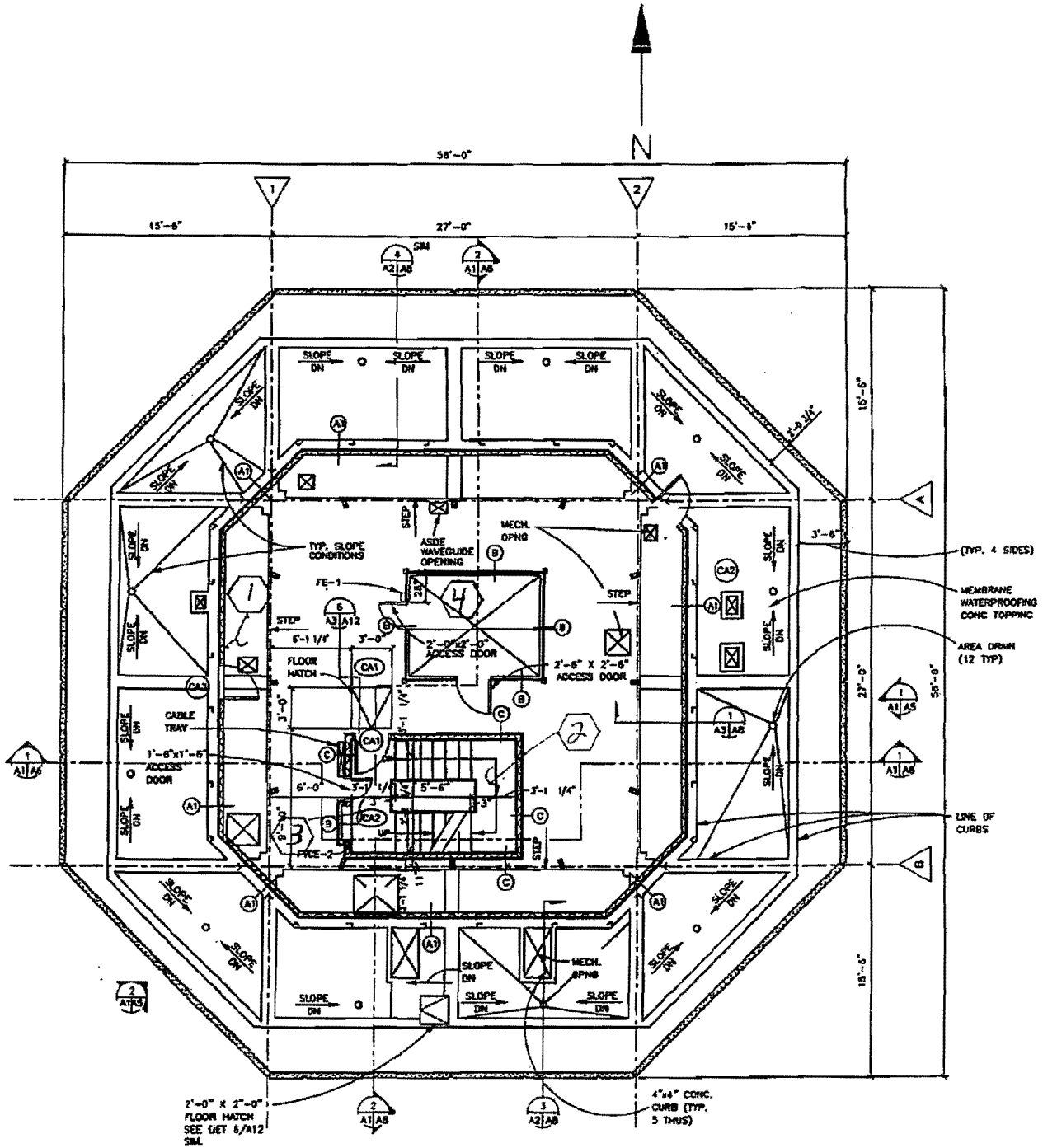

JUNCTION LEVEL NOTES

- 1 Seal the vent hole from the hot galvanizing process left in each tube handrail post (approximately 28) on the four Junction Level walkways. Fill the top of the post with expanding foam to create a backer. Clean the edges of the opening and core out foam to provide a 3/8" to 1/2" deep opening for sealant. Seal all vent holes with silicone sealant, bronze in color.
- 2 Clean all gypsum board walls in the entire elevator shaft per the Statement of Work.
- 3 Clean the entire stairwell as described in the Statement of Work. HEPA vacuum to remove all visible dust on surfaces such as stair stringers, gypsum board caps, ledges, pipes, conduits, window framing, etc. Wet wipe all surfaces in the stairwell. See the Statement of Work.
- 4 HEPA vacuum and wet wipe all supply, return, and exhaust air grilles, registers, diffusers, etc. See the Statement of Work.
- 5 HEPA vacuum all visible dust from the wall recess around the elevator doors. Clean and wet wipe all walls in the corridor to the north and east of the elevator shaft per the Statement of Work.

JUNCTION LEVEL

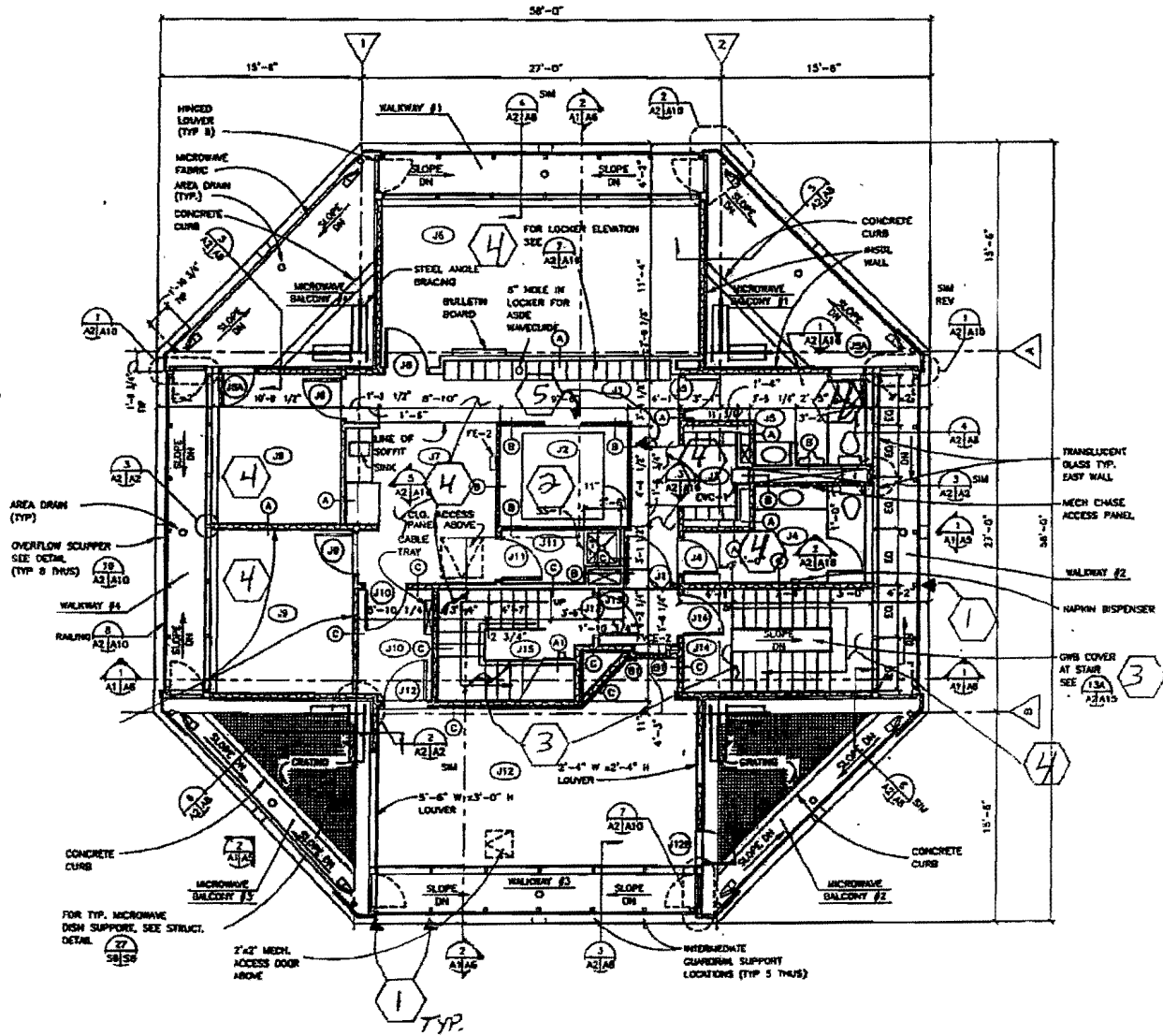

SUBJUNCTION LEVEL NOTES

- 1 Remove vinyl cove base to the first joint beyond the remediation limits. Remove one raised floor panel and carpet tile along length of wall to beyond the limits. Install a 6 mil plastic barrier between the concrete floor and the top of the raised floor to keep debris from entering this space. Install support strut to brace the raised floor as specified. Carefully remove ceiling tiles and grid components adjacent to the remediation limits and salvage materials for reinstallation upon completion of work. Install a 6 mil plastic barrier between the ceiling grid and floor deck above. Beginning at the southwest corner of the room extending northward, remove 15 LF of gypsum board to its full height of 12' (surface layer) and 13 LF for its full height of 12' (concealed layer). Remove insulation. Complete remediation work as specified. Replace any insulation removed, repair any damage to the vapor barrier, and install new gypsum board. Replace ceiling tile and any grid components removed to access the work area. Prime new gypsum board. Paint the west and NW walls in their entirety. Reinstall raised floor panels and carpet tiles. Remove temporary strut supports.

- 2 Remove and replace contaminated shaft liner panels on the west and northwest walls. The Contractor shall assume that approximately 50% of the shaft liner on the west and northwest walls will be replaced, an area equal to 20' wide to a height of 12'. Where contamination is limited to less than 50% of the shaft liner, it shall be cut out 12" beyond visible mold and only the contaminated portion shall be removed and replaced and counted against this quantity.

- 3 Cut and frame the rough openings in the walls at five locations shown and install 22" x 36" insulated, fire rated, B label, access panels. The Contractor shall install temporary supports and walk boards between the precast panels and perimeter walls on the east, north, and west sides to allow for inspection of the shaft liner. Cut and frame the rough opening in the plywood wall of room SJ7 and install a 22" x 30" non-rated access panel. Remove the temporary supports and walk boards after the inspection.

- 4 Remove vinyl cove base from the north wall. Clean and scrub the surface of the gypsum board to remove any contamination. See the Statement of Work. The existing equipment racks are approximately 3' from the wall and are installed parallel to the wall instead of perpendicular to it as shown on the drawing.

- 5 Remove vinyl cove base to the first joint beyond the remediation limits. Remove one raised floor panel and carpet tile along length of wall to beyond the limits. Install a 6 mil plastic barrier between the concrete floor and the top of the raised floor to keep debris from entering this space. Install support strut to brace the raised floor as specified. On the south wall, beginning on the west side of the

door of Mechanical Room SJ7, remove 10 LF of contaminated gypsum board to a height of approximately 36" AFF (from concrete slab to bottom of door to SJ8). Remove approximately 2 LF of contaminated gypsum board on the concealed layer to a height of 30" AFF. The concealed layer begins at the door to SJ7 and ends at the intersection with the wall between SJ7 and SJ8. Remove and replace any contaminated or water damaged insulation and contaminated or damaged vapor barrier. Install new gypsum board. Prime new gypsum board. Paint the entire wall from the SE corner of the room adjacent to stairwell SJ5 to the SW corner of the room. Reinstall raised floor panels and carpet tiles. Remove temporary strut supports.

- 6 Patch the type B shaft wall at four locations where inspection openings approximately 12" x 12" were cut through both layers of 5/8" gypsum board and the 1" shaft liner panels. Openings are located above the suspended ceiling. Cut out gypsum board at openings to adjacent studs, stagger joints, install gypsum board in openings, and fire tape joints around the perimeter of the patch.
- 7 Repair fire rated partition where a 2.5" diameter inspection hole was drilled through the surface layer of 5/8" gypsum board below raised floor on the west side of the elevator shaft. Cut out surface layer of gypsum board from floor slab to above hole, approximately 8" high, and extend horizontally to the stud on each side of the hole. Install new gypsum board.
- 8 HEPA vacuum all debris on the floor of shafts SJ6 and SJ8. Clean all surfaces per the Statement of Work. Install a 3" x 3" x 1/4" galvanized angle on the floor of the shaft to prevent water from bypassing the drain and entering the building at the opening in the slab near the column. The angle shall be set in a bed of sealant and fastened to the floor in two places with Tapcon screws. Extend the angle out to the side walls of shaft. Cut off/shorten the riser pipe from microwave balcony drain above and raise horizontal drain line if there is not sufficient room to install the 3" angle beneath it.
- 9 Remove and replace any water stained or damaged insulation on the domestic cold water line above the ceiling in the SW corner of room SJ1, adjacent to Mechanical Room SJ7. Insulate any portions of the water line or valves not currently insulated. This work includes approximately 4 LF of pipe insulation on domestic cold and/or hot water lines above the ceiling near the point of connection of the water line serving the humidifier on the south wall.
- 10 Clean all gypsum board walls in the entire elevator shaft per the Statement of Work.
- 11 Clean the entire stairwell as described in the Statement of Work. HEPA vacuum to remove all visible dust on surfaces such as stair stringers, gypsum board caps, ledges, pipes, conduits, window framing, etc. Wet wipe all surfaces in the stairwell. See the Statement of Work.

- 12 HEPA vacuum and wet wipe all supply and return air grilles, registers, diffusers, etc. See the Statement of Work.
- 13 HEPA vacuum all visible dust from the wall recess around the elevator doors. Clean and wet wipe the wall on the north side of the elevator shaft in room SJ1 per the Statement of Work.
- 14 Remove all remaining vinyl cove base in room SJ1. Install the new resilient base system specified on all walls in room SJ1.
- 15 Clean surfaces beneath the raised access floor in Equipment Room SJ1 per the Statement of Work.

11th FLOOR NOTES

- 1 Remove vinyl cove base to the first joint beyond the remediation limits. Beginning in the southwest corner, remove 3.5 LF of contaminated gypsum board to a height of 36" AFF on the surface layer and 2.25 LF to a height of 30" AFF on the concealed layer. Remove insulation. Complete remediation work as specified. Install new insulation and repair any damage to the vapor barrier. Install new gypsum board.
2. Remove vinyl cove base within the limits shown. Remove 3.5 LF of contaminated gypsum board between the SE corner of the room and the door to a height of 42" AFF. Complete remediation work as specified. Install new gypsum board.
- 3 Remove vinyl cove base within the limits shown. Remove 10.5 LF of contaminated gypsum board between the SE corner of the room to the door to 11TS5A to a height of 48" AFF on the surface layer and to a height of 42" AFF on the concealed layer. Remove the lower section of struts supporting the conduit sleeve and ground cables through the wall if necessary to install the new gypsum board and provide temporary support for the remaining strut. Reinstall existing strut sections after the installation of new gypsum board. Complete remediation work as specified. Install new gypsum board.
- 4 Remove vinyl cove base within the limits shown. Remove 2.5 LF of contaminated gypsum board between the SW corner of the room and the door to 11TS5 to a height of 48" AFF on the surface layer and to a height of 42" AFF on the concealed layer. Complete remediation work as specified.
- 5 Remove door and frame 11TS5A. The lockset and closer shall remain the property of the FAA. Remove the lower portion of the gypsum board wall and metal studs between the NW corner of the elevator shaft and the wall to the north. Install a header between the NW corner of the elevator shaft and the north wall to support the wall above with the bottom of the finished wall (opening) 7' AFF. A short section of wall may be left at each end to support the header. This will create a 7' high opening across the west wall of 11TS5A. This opening is being created since the limited space in 11TS5A between panel DPCT-6 and the wall makes it difficult to restore the fire rated walls. Remove the conduit and wiring for the light switch in room 11TS5A and rewire the lights to operate off of the light switch for room 11TS5. Patch any penetrations through rated walls where conduits are removed. Install gypsum board to restore the 2-hour rating at the NW corner of the elevator shaft. Install two layers of gypsum board on all modified sections of wall and header between room 11TS5 and 11TS5A. Install a 1 5/8" galvanized strut rack bolted to the floor and header to support the central battery system electrical panel in room 11TS5 where the wall is being removed.

- 6 Remove vinyl cove base to the first joint beyond the remediation limits. Beginning in the SW corner, remove 4 LF of contaminated gypsum board to a height of 18" AFF on the surface layer and 2.67 LF of contaminated gypsum board to a height of 12" AFF on the concealed layer. Complete remediation work as specified. Install new gypsum board.
- 7 Remove vinyl cove base within the limits shown. Remove contaminated gypsum board for the length of the south wall, approximately 3.5 LF, to a height of 18" AFF on the surface layer and to a height of 12" on the concealed layer. Complete remediation work as specified. Install new gypsum board.
- 8 Remove all gypsum board scraps, debris, and fire safing insulation from the void between the edge of the floor slab and the exterior precast wall panels. The majority of this material is contaminated. This area includes the entire perimeter of the tower shaft. Install new fire safing insulation in the void between the floor slab and the exterior precast wall panels as specified.
- 9 Cut and frame the rough opening and install an 18" x 24" insulated, fire rated, B label, access panel in the ceiling of corridor 11TS1.
- 10 Remove and replace approximately 11 LF of water stained pipe insulation on the storm sewer piping beneath the floor drain for SJ6 in the outer ring area. Water test the drain and piping for 10 minutes and check for leaks. Correct any leaks found in piping connections.
- 11 Clean all gypsum board walls in the entire elevator shaft per the Statement of Work.
- 12 Clean the entire stairwell as described in the Statement of Work. HEPA vacuum to remove all visible dust on surfaces such as stair stringers, gypsum board caps, ledges, pipes, conduits, window framing, etc. Wet wipe all surfaces in the stairwell. See the Statement of Work.
- 13 HEPA vacuum all visible dust from the wall recess around the elevator doors. Clean and wet wipe walls in the corridor (11TS1) per the Statement of Work.

10th FLOOR NOTES

- 1 Remove vinyl cove base within the remediation limits. Remove 21.5 LF of contaminated gypsum board between the NE corner up to and including the west wall of the NW column enclosure to a height of 72" AFF on the surface layer and to a height of 60" AFF on the concealed layer. Remove insulation. The Contractor shall assume that a quantity equal to approximately 5 pieces of shaft liner, each 2' wide to a height of 5' are contaminated and must be replaced. Where contamination is limited, it shall be cut out 12" beyond visible mold and only the contaminated portion shall be removed and replaced. Complete remediation work as specified. Replace insulation and repair any damage to the vapor barrier. Install new gypsum board.
- 2 Remove vinyl cove base within the remediation limits. Remove 7.25 LF of contaminated gypsum board from the NE corner of the room to the elevator shaft to a height of 24" AFF on the surface layer and 12" AFF on the concealed layer. Complete remediation work as specified. Install new gypsum board.
- 3 Remove vinyl cove base within the remediation limits. Remove 9.67 LF of contaminated gypsum board from the north side of the elevator shaft to a height of 48" AFF on the surface layer and to a height of 24" AFF on the concealed layer. Complete remediation work as specified. Install new gypsum board.
- 4 Remove vinyl cove base within the remediation limits. Remove 7.83 LF of contaminated gypsum board from the west side of the elevator shaft to a height of 48" AFF on the surface layer and to a height of 24" AFF on the concealed layer. Complete remediation work as specified. Install new gypsum board.
- 5 Remove vinyl cove base within the remediation limits. Remove 3 LF of contaminated gypsum board between the east wall and the door to room 10TS4 to a height of 48" AFF on the surface layer and to a height of 24" AFF on the concealed layer. Complete remediation work as specified. Install new gypsum board.
- 6 Remove vinyl cove base to the first joint beyond the remediation limits shown. Remove contaminated gypsum board from the column enclosure in the NE corner for a minimum of 4.83 LF to the south to a height of 24" AFF on the surface layer. Remove contaminated gypsum board from the column enclosure in the NE corner for a minimum of 3.5 LF to the south to a height of 18" AFF on the concealed layer. Remove insulation and repair any damage to the vapor barrier. Complete remediation work as specified. Replace insulation. Install new gypsum board.

- 7 Cut and frame the rough opening and install a 16" x 20" non-rated access panel in the ceiling of corridor 10TS1.
- 8 Repair the fire rated partition where a 2.5" diameter inspection hole was drilled through two layers of 5/8" gypsum board (approximately 9' AFF). Cut out the surface layer of gypsum board 12" high centered on hole and extend horizontally to the second stud beyond on each side of the hole. Cut out the concealed layer of gypsum board to 6" high centered on the hole and extend horizontally to the stud on each side of the hole. Install new gypsum board.
- 9 Remove and replace approximately 3 LF of water stained pipe insulation on overhead hot water supply piping in room 10TS3.
- 10 Clean all gypsum board walls in the entire elevator shaft per the Statement of Work.
- 11 Clean the entire stairwell as described in the Statement of Work. HEPA vacuum to remove all visible dust on surfaces such as stair stringers, gypsum board caps, ledges, pipes, conduits, window framing, etc. Wet wipe all surfaces in the stairwell. See the Statement of Work.
- 12 Cut and frame the rough opening and install a 22" x 36" insulated, fire rated, B label, access panel in the south wall of the stairwell. Locate the bottom of the panel 24" above the landing.
- 13 HEPA vacuum all visible dust from the wall recess around the elevator doors. Clean and wet wipe all walls in the corridor (10TS1) per the Statement of Work.
- 14 Contract Option 2: Prime water stains on the ceiling of stair vestibule 10TS6 with two coats of stain blocking primer. Paint the entire ceiling of 10TS6. This option also includes additional work in corridor 9TS1.

10TH FLOOR

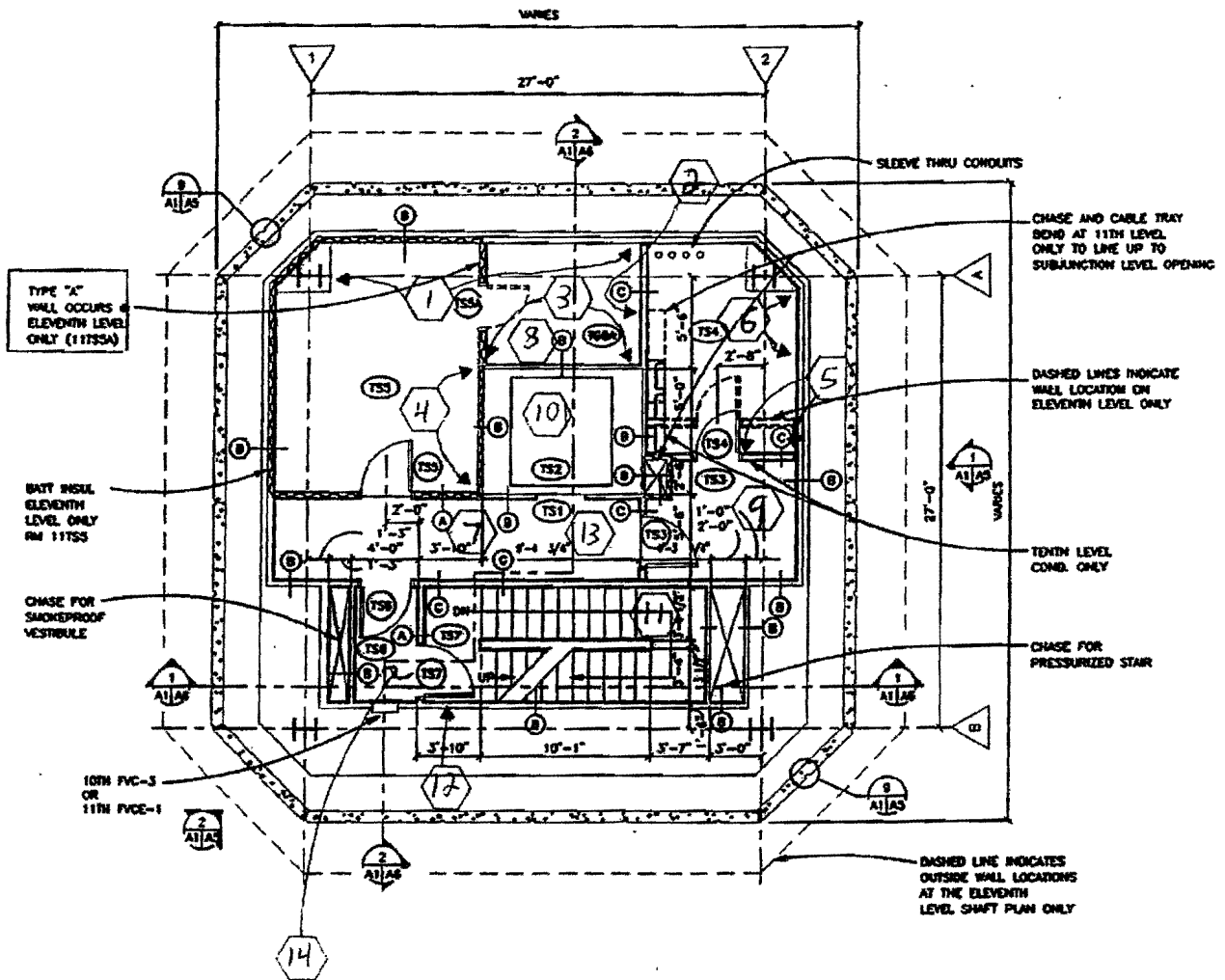

TYPE "A" WALL OCCURS @ ELEVENTH LEVEL ONLY (117SSA)

BATT INSUL ELEVENTH LEVEL ONLY RM 117SS

CHASE FOR SMOKEPROOF VESTIBULE

10TH FVC-3 OR 11TH FVC-1

SLEEVE THRU CONDUITS

CHASE AND CABLE TRAY BEND AT 11TH LEVEL ONLY TO LINE UP TO SUBJUNCTION LEVEL OPENING

DASHED LINES INDICATE WALL LOCATION ON ELEVENTH LEVEL ONLY

TENTH LEVEL CONDUIT ONLY

CHASE FOR PRESSURIZED STAIR

DASHED LINE INDICATES OUTSIDE WALL LOCATIONS AT THE ELEVENTH LEVEL SHAFT PLAN ONLY

9th FLOOR NOTES

- 1 Remove and replace approximately 3 LF of water stained pipe insulation on the overhead hot water supply piping in room 9TS3.
- 2 Repair the fire rated partition between 9TS5 and 9TS4 where a 2.5" diameter inspection hole was drilled through the surface layer of 5/8" gypsum board (approximately 1' AFF). Cut out the surface layer of gypsum board 16" AFF and extend horizontally to the stud on each side of the hole. Install new gypsum board.
- 3 Clean all gypsum board walls in the entire elevator shaft per the Statement of Work. Pre-clean the contaminated area approximately 10 feet below the 9th floor.
- 4 Clean the entire stairwell as described in the Statement of Work. HEPA vacuum to remove all visible dust on surfaces such as stair stringers, gypsum board caps, ledges, pipes, conduits, window framing, etc. Wet wipe all surfaces in the stairwell. See the Statement of Work.
- 5 Cut and frame the rough opening and install a 24" x 36" non-rated access panel in the south wall of the stairwell. Locate the bottom of the panel approximately 24" above the landing.
- 6 HEPA vacuum all visible dust from the wall recess around the elevator doors. Clean and wet wipe all walls in the corridor (9TS1) per the Statement of Work. Scrub and clean floor tile at west end of corridor to remove white water stains between floor tiles.
- 7 Contract Option 2: remove, repair, and refinish the water damaged tape joint along the ceiling at the west wall in corridor 9TS1. Apply two coats of a stain blocking primer to the water stains along the west wall and a portion of the south wall. Repaint the entire ceiling of corridor 9TS1. This option also includes additional work in stair vestibule 10TS6.

9TH FLOOR

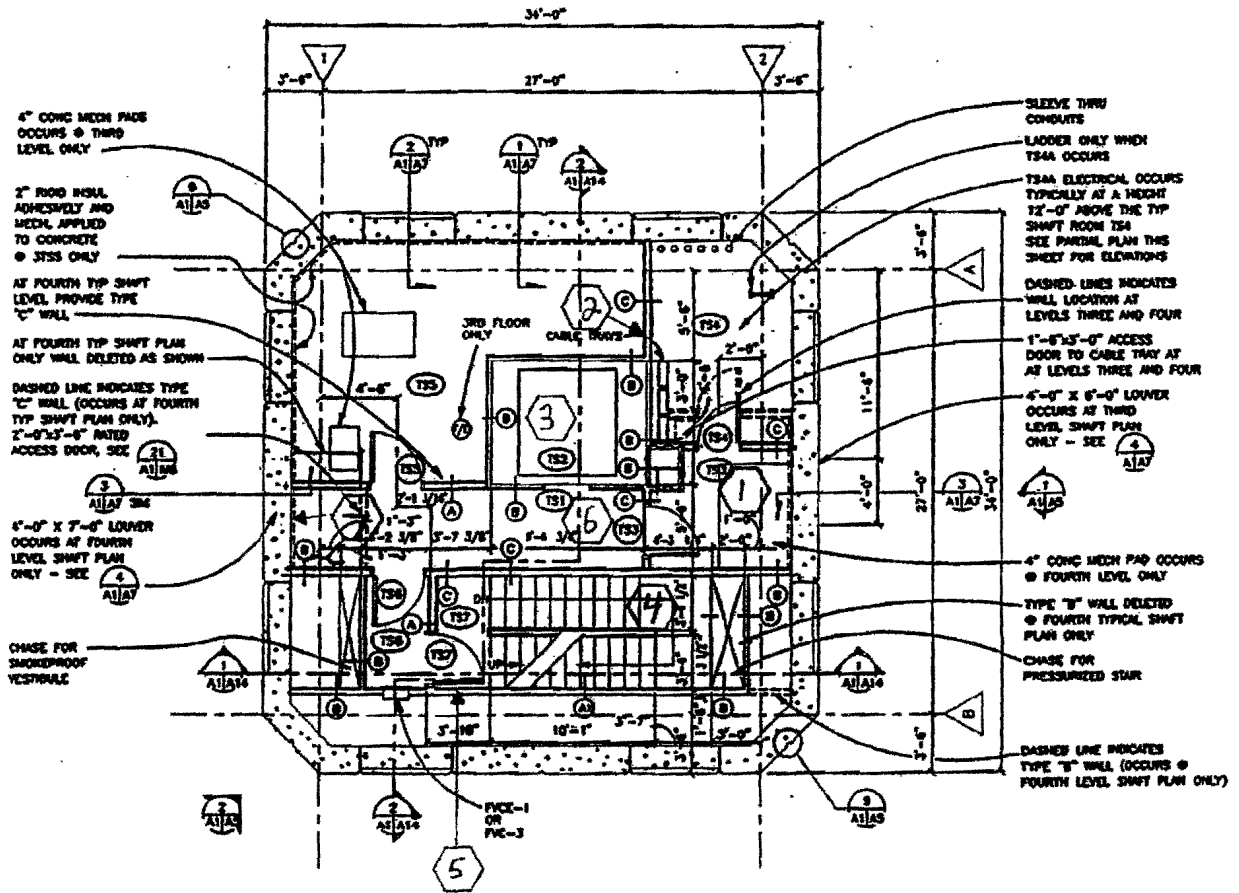

8th FLOOR NOTES

- 1 Cut and frame the rough opening and install a 24" x 48" non-rated access panel in the ceiling of corridor 8TS1. Locate the opening to provide access to the contaminated gypsum board above the ceiling. The Contractor may at his option remove and replace a portion of the ceiling in 8TS1 to access this work area instead of installing this access panel. Ceiling replacement includes reinstallation of the gypsum board ceiling, framing, taping and finishing, painting the entire ceiling and any walls affected, etc.
- 2 Remove an area of contaminated gypsum board from the area above the ceiling of 8TS1. Remove an area of stained and contaminated gypsum board above the horizontal beam approximately 6' wide to a height of 4' on the surface layer and 5' wide to a height of 3' on the concealed layer. Cut out to existing studs and stager joints. Gypsum board on the opposite side of the wall shall be removed to allow replacement gypsum board to be passed through the wall into the space above the ceiling of 8TS6. Complete remediation work as specified. Install new gypsum board.
- 3 Remove an area of contaminated gypsum board from the area above the ceiling of 8TS6. Remove an area of stained and contaminated gypsum board approximately 4' wide to a height of 5' on the surface layer and 32" wide to a height of 4' on the concealed layer. Remove additional gypsum board on the north wall to provide an opening to pass new materials through the wall from the space above the ceiling of 8TS1. Cut out to existing studs and stager joints. Complete remediation work as specified. Install new gypsum board. The Contractor may at his option remove and replace the ceiling in 8TS6 and/or install a larger access panel to access this area. Ceiling replacement includes reinstallation of gypsum board ceiling, framing, light fixture, access door, fire stopping, painting, etc.
- 4 Clean all gypsum board walls in the entire elevator shaft per the Statement of Work.
- 5 Clean the entire stairwell as described in the Statement of Work. HEPA vacuum to remove all visible dust on surfaces such as stair stringers, gypsum board caps, ledges, pipes, conduits, window framing, etc. Wet wipe all surfaces in the stairwell. See the Statement of Work.
- 6 Cut and frame the rough opening and install a 24" x 36" non-rated access panel in the south wall of the stairwell. Locate the bottom of the panel approximately 24" above the landing.
- 7 HEPA vacuum all visible dust from the wall recess around the elevator doors. Clean and wet wipe all walls in the corridor (8TS1) per the Statement of Work.

- 8 Remove a 3' high x 6' wide section of gypsum board on the surface layer and a 2' high x 4' wide section of gypsum board on the concealed layer of the south wall beginning at the NW corner of the elevator shaft and extending to the east. Center the opening approximately 13'-6" AFF to coincide with the location of mold found on the shaft liner panel in the elevator shaft. This opening will be used to inspect the concealed side of the shaft liner for the presence of mold at this location. Complete remediation work as specified. Install new gypsum board.

7th FLOOR NOTES

- 1 Clean all gypsum board walls in the entire elevator shaft per the Statement of Work.
- 2 Clean the entire stairwell as described in the Statement of Work. HEPA vacuum to remove all visible dust on surfaces such as stair stringers, gypsum board caps, ledges, pipes, conduits, window framing, etc. Wet wipe all surfaces in the stairwell. See the Statement of Work.
- 3 Cut and frame the rough opening and install a 24" x 36" non-rated access panel in the south wall of the stairwell. Locate the bottom of the panel approximately 24" above the landing.
- 4 HEPA vacuum all visible dust from the wall recess around the elevator doors. Clean and wet wipe all walls in the corridor (7TS1) per the Statement of Work.

6th FLOOR NOTES

- 1 Clean all gypsum board walls in the entire elevator shaft per the Statement of Work.
- 2 Clean the entire stairwell as described in the Statement of Work. HEPA vacuum to remove all visible dust on surfaces such as stair stringers, gypsum board caps, ledges, pipes, conduits, window framing, etc. Wet wipe all surfaces in the stairwell. See the Statement of Work.
- 3 Cut and frame the rough opening and install a 24" x 36" non-rated access panel in the south wall of the stairwell. Locate the bottom of the panel approximately 24" above the landing.
- 4 HEPA vacuum all visible dust from the wall recess around the elevator doors. Clean and wet wipe all walls in the corridor (6TS1) per the Statement of Work.

6TH FLOOR

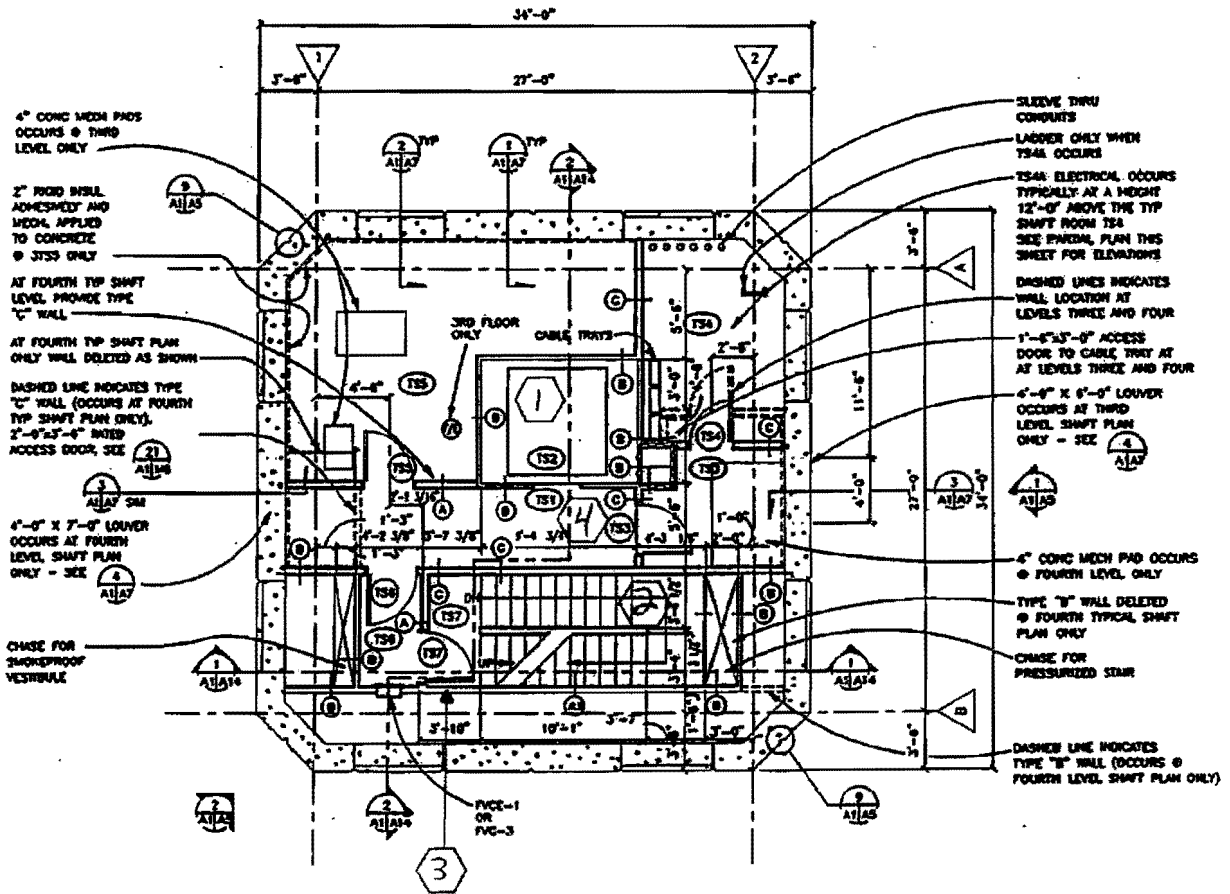

5th FLOOR NOTES

- 1 Cut and frame the rough opening and install a 16" x 20" access panel in the ceiling of corridor 5TS1.
- 2 Clean all gypsum board walls in the entire elevator shaft per the Statement of Work.
- 3 Clean the entire stairwell as described in the Statement of Work. HEPA vacuum to remove all visible dust on surfaces such as stair stringers, gypsum board caps, ledges, pipes, conduits, window framing, etc. Wet wipe all surfaces in the stairwell. See the Statement of Work.
- 4 Cut and frame the rough opening and install a 24" x 36" non-rated access panel in the south wall of the stairwell. Locate the bottom of the panel approximately 24" above the landing.
- 5 HEPA vacuum all visible dust from the wall recess around the elevator doors. Clean and wet wipe all walls in the corridor (5TS1) per the Statement of Work.

5TH FLOOR

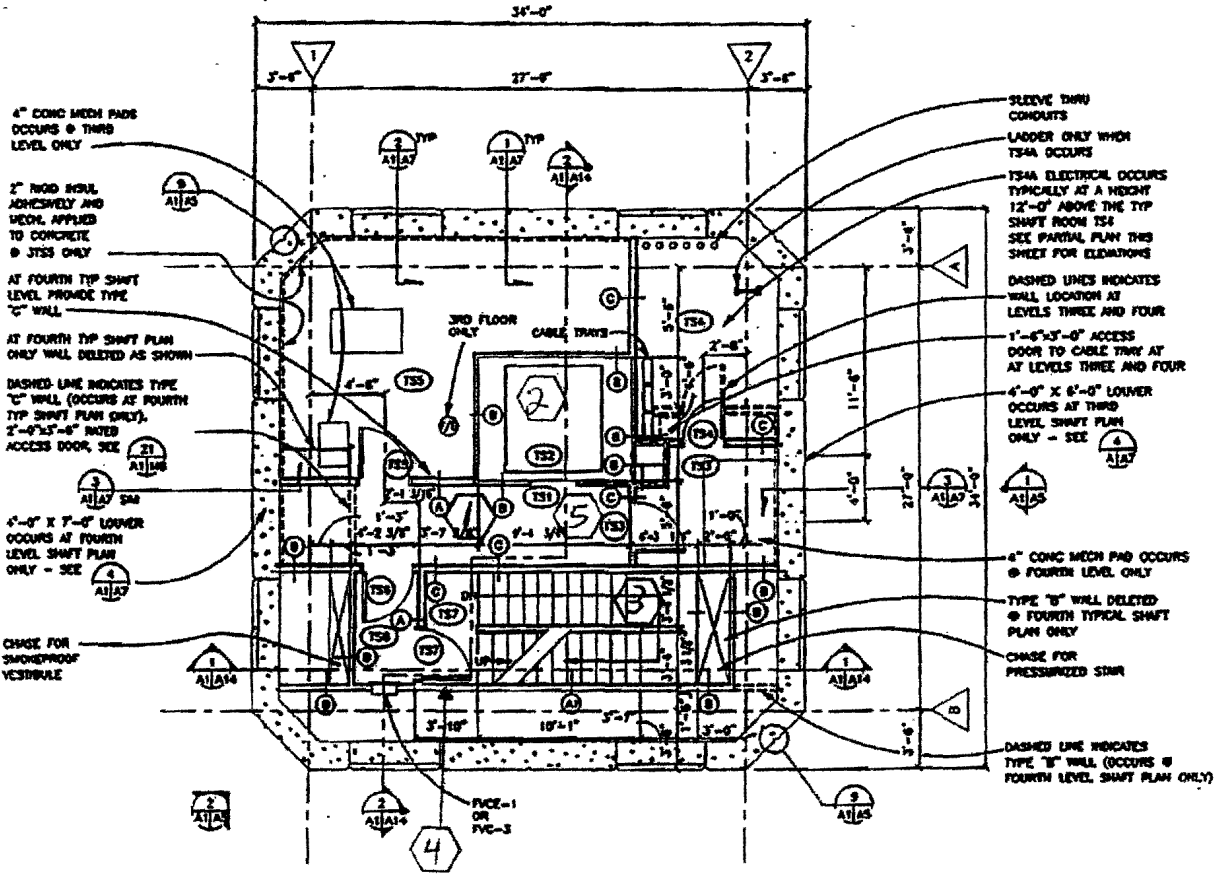

4" CONC MECH PAD OCCURS @ THIRD LEVEL ONLY

2" MOD BRUL ADHESIVELY AND MECH. APPLIED TO CONCRETE @ JTS ONLY

AT FOURTH TYP SHAFT LEVEL PROMOTE TYPE "C" WALL

AT FOURTH TYP SHAFT PLAN ONLY WALL DELETED AS SHOWN

DASHED LINE INDICATES TYPE "C" WALL (OCCURS AT FOURTH TYP SHAFT PLAN ONLY). 2'-0" X 7'-0" INTER ACCESS DOOR. SEE

4'-0" X 7'-0" LOUVER OCCURS AT FOURTH LEVEL SHAFT PLAN ONLY - SEE

CHANGE FOR SHOCKPROOF VESTIBULE

FACE-1 OR PVC-3

SLEEVE THRU CONDUITS LADDER ONLY WHEN T34A OCCURS

T34A ELECTRICAL OCCURS TYPICALLY AT A HEIGHT 12'-0" ABOVE THE TYP SHAFT ROOM T32 SEE PARTIAL PLAN THIS SHEET FOR ELEVATIONS

DASHED LINES INDICATES WALL LOCATION AT LEVELS THREE AND FOUR

1'-6" X 3'-0" ACCESS DOOR TO CABLE TRAY AT LEVELS THREE AND FOUR

4'-0" X 6'-0" LOUVER OCCURS AT THIRD LEVEL SHAFT PLAN ONLY - SEE

4" CONC MECH PAD OCCURS @ FOURTH LEVEL ONLY

TYPE "B" WALL DELETED @ FOURTH TYPICAL SHAFT PLAN ONLY

CHANGE FOR PRESSURIZED SHAFT

DASHED LINE INDICATES TYPE "B" WALL (OCCURS @ FOURTH LEVEL SHAFT PLAN ONLY)

4th FLOOR NOTES

- 1 Remove vinyl cove base within the remediation limits. Remove 3 LF of contaminated gypsum board between the door and the east precast wall to a height of 24" AFF on the surface layer and to a height of 18" AFF on the concealed layer. Complete remediation work as specified. Install new gypsum board.
- 2 Remove and replace approximately 5 LF of water stained or contaminated pipe insulation on the overhead chilled water lines in room 4TS3. Insulate uninsulated piping and caps for future connection.
- 3 Clean all gypsum board walls in the entire elevator shaft per the Statement of Work.
- 4 Clean the entire stairwell as described in the Statement of Work. HEPA vacuum to remove all visible dust on surfaces such as stair stringers, gypsum board caps, ledges, pipes, conduits, window framing, etc. Wet wipe all surfaces in the stairwell. See the Statement of Work.
- 5 Cut and frame the rough opening and install a 24" x 36" non-rated access panel in the south wall of the stairwell. Locate the bottom of the panel approximately 24" above the landing.
- 6 HEPA vacuum all visible dust from the wall recess around the elevator doors. Clean and wet wipe all walls in the corridor (4TS1) per the Statement of Work.
- 7 Contract Option 3: Remove the existing outside air intake louver. Modify the existing sheet metal plenum (sleeve) to fit the thicker replacement louver. Install a new wind-driven rain resistant stationary louver as specified. Seal between the louver, sleeve, and the precast concrete as specified.

4TH FLOOR

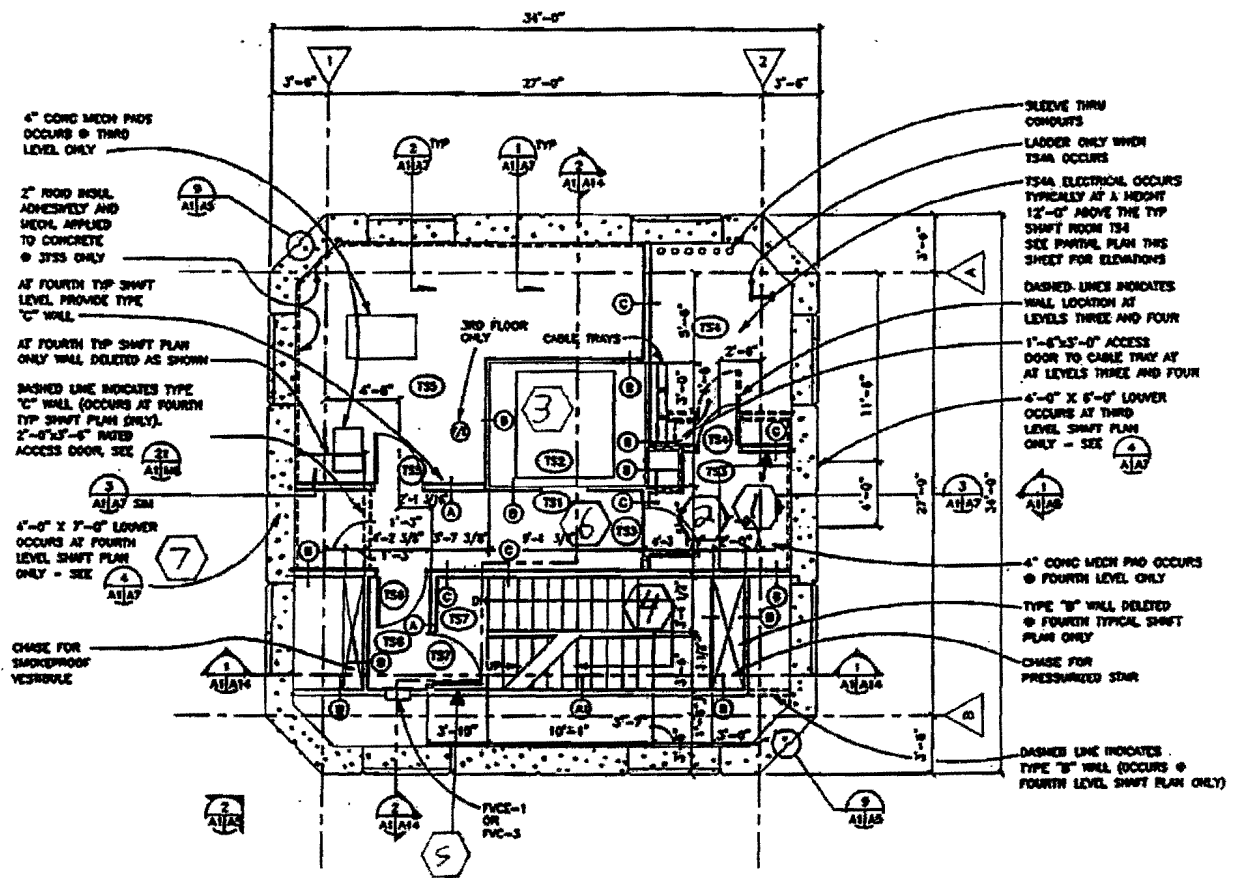

4" CONC MECH PDS OCCURS @ THIRD LEVEL ONLY

2" ROD REIN. ADHESIVELY AND MECH. APPLIED TO CONCRETE @ STES ONLY

AT FOURTH TYP SHFT LEVEL PROVIDE TYPE "C" WALL

AT FOURTH TYP SHFT PLAN ONLY WALL DELETED AS SHOWN

DASHED LINE INDICATES TYPE "C" WALL (OCCURS AT FOURTH TYP SHFT PLAN ONLY). 2'-6" X 5'-6" RATED ACCESS DOOR, SEE

4'-0" X 7'-0" LOWER OCCURS AT FOURTH LEVEL SHFT PLAN ONLY - SEE

CHASE FOR SMOKEPROOF VESTIBULE

SLEEVE THRU CONDUITS

LADDER ONLY WHEN T34A OCCURS

T34A ELECTRICAL OCCURS TYPICALLY AT A HEIGHT 12'-0" ABOVE THE TYP SHFT ROOM T34 SEE PARTIAL PLAN THIS SHEET FOR ELEVATIONS

DASHED LINE INDICATES WALL LOCATION AT LEVELS THREE AND FOUR

1'-6" X 5'-0" ACCESS DOOR TO CABLE TRAY AT LEVELS THREE AND FOUR

4'-0" X 5'-0" LOWER OCCURS AT THIRD LEVEL SHFT PLAN ONLY - SEE

4" CONC MECH PND OCCURS @ FOURTH LEVEL ONLY

TYPE "B" WALL DELETED @ FOURTH TYPICAL SHFT PLAN ONLY

CHASE FOR PRESSURIZED STAIR

DASHED LINE INDICATES TYPE "B" WALL (OCCURS @ FOURTH LEVEL SHFT PLAN ONLY)

3RD FLOOR ONLY CABLE TRAYS

PVC-1 OR PVC-3

3rd FLOOR NOTES

- 1 Remove all vinyl cove base within the room.
- 2 Remove contaminated gypsum board on the north wall, 19 LF, on the northwest wall, 3.33 LF, and on the west wall, 12.1 LF, to a height of 3'. The gypsum board is utilized as a thermal barrier over the existing foam insulation. It is screwed on only without any tape or finish on joints. Complete remediation work as specified. Install new gypsum board (no tape or finish).
- 3 Remove contaminated gypsum board on the two east walls, 14.3 LF, to a height of 36" AFF on the surface layer and to a height of 24" on the concealed layer. Complete remediation work as specified. Install new gypsum board.
- 4 Remove contaminated gypsum board on both sides of the door to the corridor, 8 LF, to a height of 3'9". Complete remediation work as specified. Install new gypsum board.
- 5 On the south wall adjacent to the elevator shaft, gypsum board removal will occur with the fire pump panels left in place. Remove contaminated gypsum board along the entire length of the wall, 10 LF, to a height of 6" AFF on the surface layer and to a height of 4" AFF on the concealed layer. Remove additional gypsum board if contaminated on the east and west ends of fixed equipment, approximately 4 LF, to a height of 36" AFF on the surface layer and to a height of 30" AFF on the concealed layer. Complete remediation work as specified. Install new gypsum board.
- 6 Remove vinyl cove base within the remediation limits. Remove water stained and contaminated gypsum board across full length of the east wall, 9.6 LF to a height of 8' AFF. The gypsum board is utilized as a thermal barrier over the existing foam insulation. It is screwed on only without any tape or finish on joints. Complete remediation work as specified. Install new gypsum board (no tape or finish).
- 7 Remove and replace approximately 10 LF of contaminated and water stained pipe insulation on the overhead hot water supply and return lines. Insulate uninsulated piping, fittings, and components. Provide re-enterable insulation on valves, strainers, etc. to allow access for maintenance.
- 8 Clean all gypsum board walls in the entire elevator shaft per the Statement of Work.
- 9 Clean the entire stairwell as described in the Statement of Work. HEPA vacuum to remove all visible dust on surfaces such as stair stringers, gypsum board caps,

ledges, pipes, conduits, window framing, etc. Wet wipe all surfaces in the stairwell. See the Statement of Work.

- 10 Cut and frame the rough opening and install a 24" x 36" non-rated access panel in the south wall of the stairwell. Locate the bottom of the panel approximately 24" above the landing.
- 11 HEPA vacuum all visible dust from the wall recess around the elevator doors. Clean and wet wipe all walls in the corridor (3TS1) per the Statement of Work.
- 12 Contract Option 4: Remove the existing exhaust louver. Modify the existing sheet metal plenum (sleeve) to fit the thicker replacement louver. Install a new wind-driven rain resistant stationary louver as specified. Seal between the louver, sleeve, and the precast concrete as specified. The louver size is slightly smaller than shown on the drawing, see the section on louvers in the Supplemental Statement of work and field verify the size.

2nd FLOOR NOTES

- 1 Remove vinyl cove base to the first joint beyond the remediation limits. Beginning in the NE corner, remove 6.5 LF of contaminated gypsum board to a height of 24" AFF. Complete remediation work as specified. Install new gypsum board. Prime new gypsum board. Paint patched area. Paint entire north wall with one coat of paint.
- 2 Insulate 1 LF of uninsulated chilled water return piping passing between two metal studs adjacent to the door between the corridor and room 2TS5. Trim flange of metal stud to install insulation and brace cut studs to adjacent uncut studs with a section of metal stud or runner.
- 3 Repair fire rated partition where a 2.5" diameter inspection hole was drilled through the surface layer of 5/8" gypsum board behind the vinyl cove base. Cut out the surface layer of gypsum board approximately 3" high (from floor to top of hole) and extend horizontally to the stud beyond on each side of the hole. Install new gypsum board.
- 4 Clean all gypsum board walls in the entire elevator shaft per the Statement of Work.
- 5 Clean the entire stairwell as described in the Statement of Work. HEPA vacuum to remove all visible dust on surfaces such as stair stringers, gypsum board caps, ledges, pipes, conduits, window framing, etc. Wet wipe all surfaces in the stairwell. See the Statement of Work.
- 6 Cut and frame the rough opening and install a 24" x 36" non-rated access panel in the south wall of the stairwell. Locate the bottom of the panel approximately 24" above the landing.
- 7 HEPA vacuum and wet wipe all supply and return air grilles, registers, diffusers, etc. Include the connecting link between the ATCT shaft and Base Building. See the Statement of Work.
- 8 Contract Option 6: Paint all walls in room 2TS5 with one finish coat of paint. The north wall is not included in this option; it is required to be painted in note 1. The wall line/configuration varies along the west wall due to additional furred out chases that are not shown on the drawing.

GROUND FLOOR NOTES

- 1 Remove approximately 14 square feet of water stained gypsum board covering the rigid insulation beneath the outside air duct. The gypsum board is utilized as a thermal barrier over the existing foam insulation. It is screwed on only without any tape or finish on joints. Complete remediation work as specified. Install new gypsum board (no tape or finish).
- 2 Clean the entire stairwell as described in the Statement of Work. HEPA vacuum to remove all visible dust on surfaces such as stair stringers, gypsum board caps, ledges, pipes, conduits, window framing, etc. Wet wipe all surfaces in the stairwell. See the Statement of Work.
- 3 Cut and frame the rough opening and install a 24" x 36" non-rated access panel in the south wall of the stairwell. Locate the bottom of the panel approximately 24" above the landing (above conduit for ground wire).
- 4 HEPA vacuum and wet wipe all supply and return air grilles, registers, diffusers, etc. Include the connecting link between the ATCT shaft and base building. See the Statement of Work.
- 5 Clean all gypsum board walls in the entire elevator shaft per the Statement of Work.

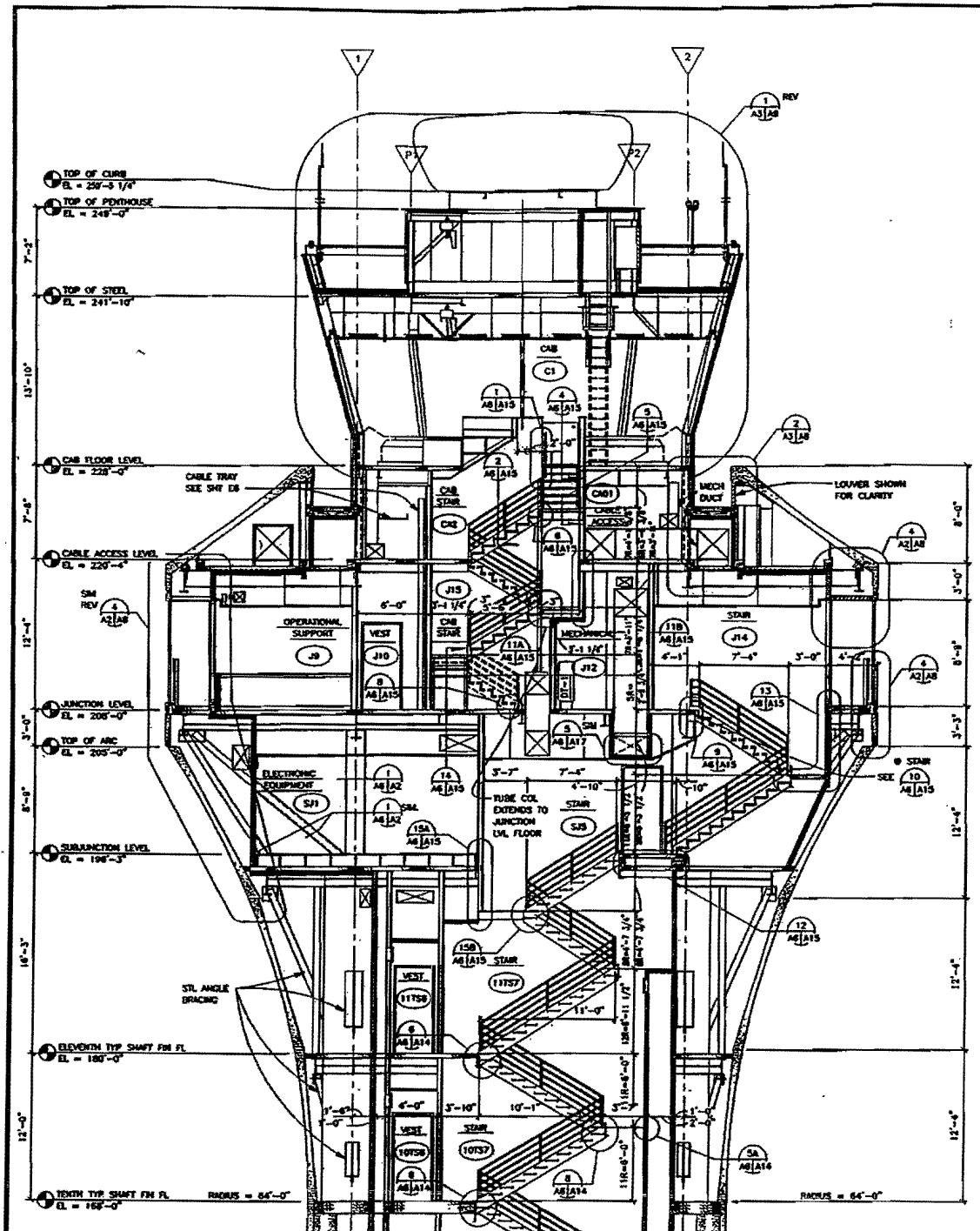

BUILDING SECTION
SCALE: 1/4" = 1'-0"
A1/56

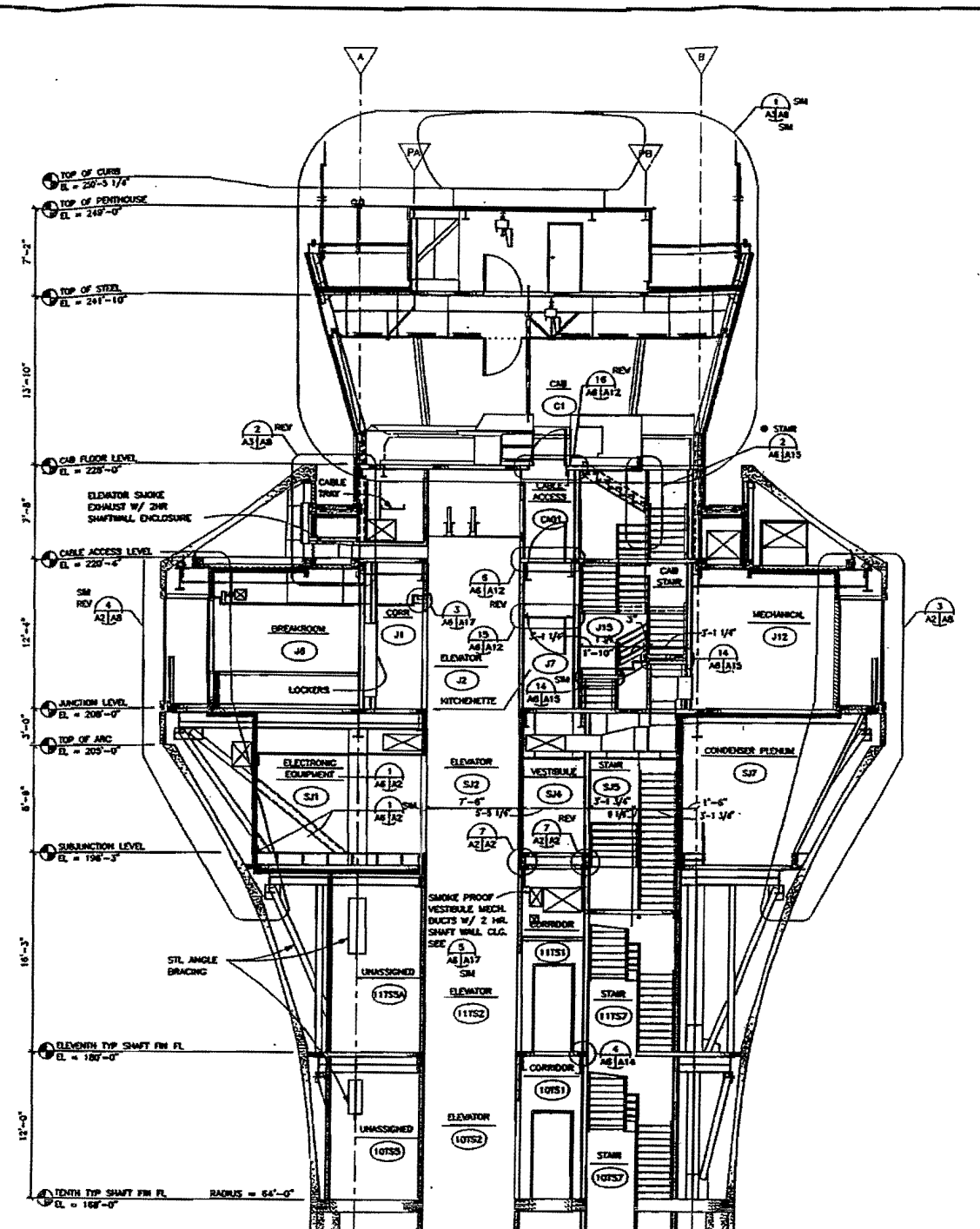

BUILDING SECTION
SCALE: 1/4" = 1'-0"
A1/56

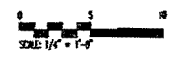

| | | | |
|---|--|-------------------------|-------------------------|
| 1 07/94/97 AS-0417 (9/1/96) | | 52084 | 022 |
| DEPARTMENT OF TRANSPORTATION FEDERAL AVIATION ADMINISTRATION CENTRAL REGION KANSAS CITY, MISSOURI MAJOR ACTIVITY LEVEL AIRPORT TRAFFIC CONTROL TOWER BUILDING SECTIONS KANSAS CITY INTERNATIONAL AIRPORT KANSAS CITY, MISSOURI | | | |
| DESIGNED BY H & N | PROJECT NO. 901 EIGHT SEVENTH KANSAS CITY, MISSOURI 64108 | DATE JUNE 1, 1993 | BY John J. Spachner |
| CHECKED BY H & N | DATE JUNE 1, 1993 | BY Andrew J. Holcomb | DATE JUNE 1, 1993 |
| DATE JUNE 1, 1993 | BY John J. Spachner | DATE JUNE 1, 1993 | BY Andrew J. Holcomb |
| DATE JUNE 1, 1993 | BY John J. Spachner | DATE JUNE 1, 1993 | BY Andrew J. Holcomb |
| DATE JUNE 1, 1993 | BY John J. Spachner | DATE JUNE 1, 1993 | BY Andrew J. Holcomb |
| DATE JUNE 1, 1993 | BY John J. Spachner | DATE JUNE 1, 1993 | BY Andrew J. Holcomb |
| DATE JUNE 1, 1993 | BY John J. Spachner | DATE JUNE 1, 1993 | BY Andrew J. Holcomb |
| DATE JUNE 1, 1993 | BY John J. Spachner | DATE JUNE 1, 1993 | BY Andrew J. Holcomb |

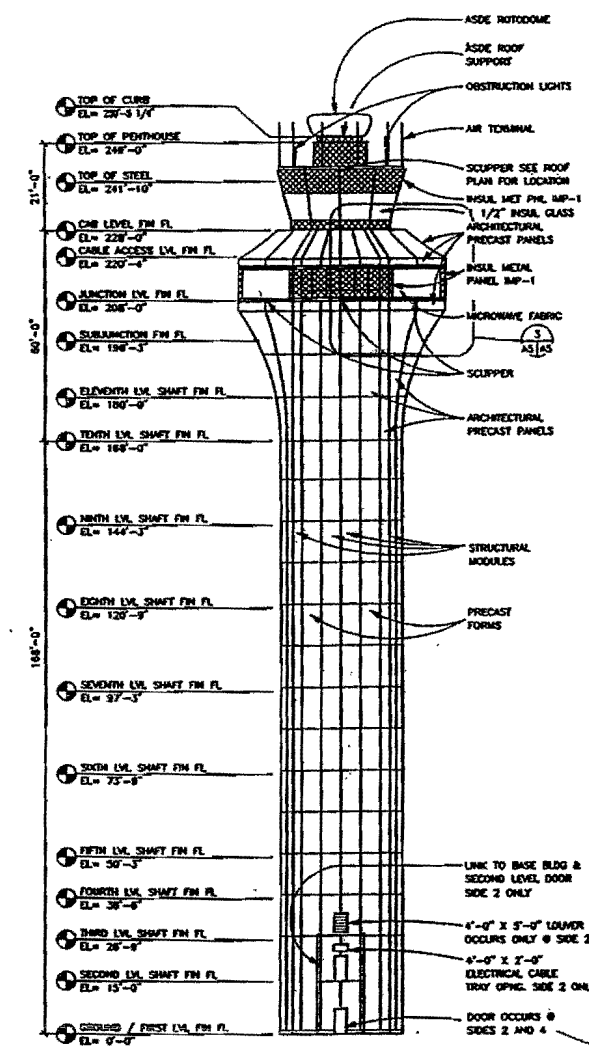

ELEVATION @ SIDE 2
SCALE: 1/16" = 1'-0"

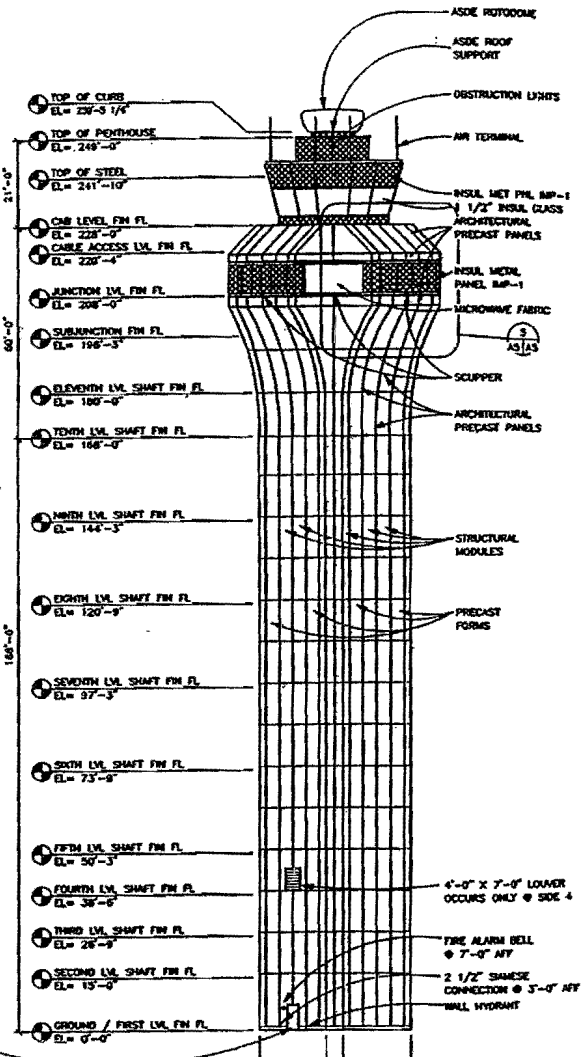

ELEVATION
SCALE: 1/16" = 1'-0"

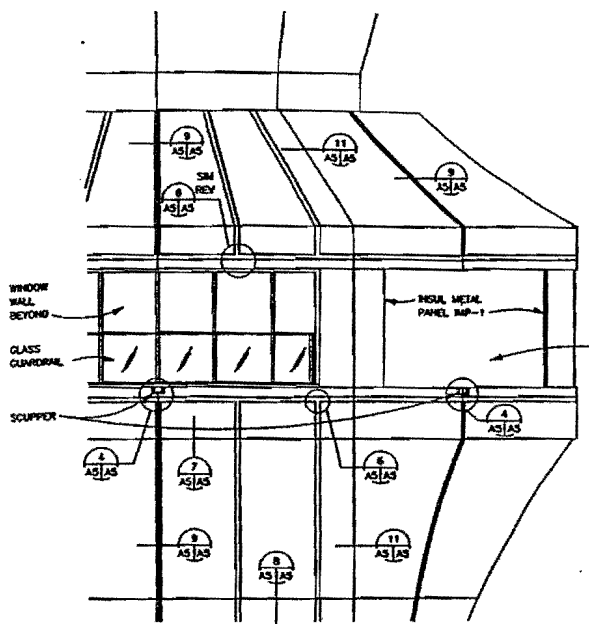

PARTIAL ELEVATION
SCALE: 1/4" = 1'-0"

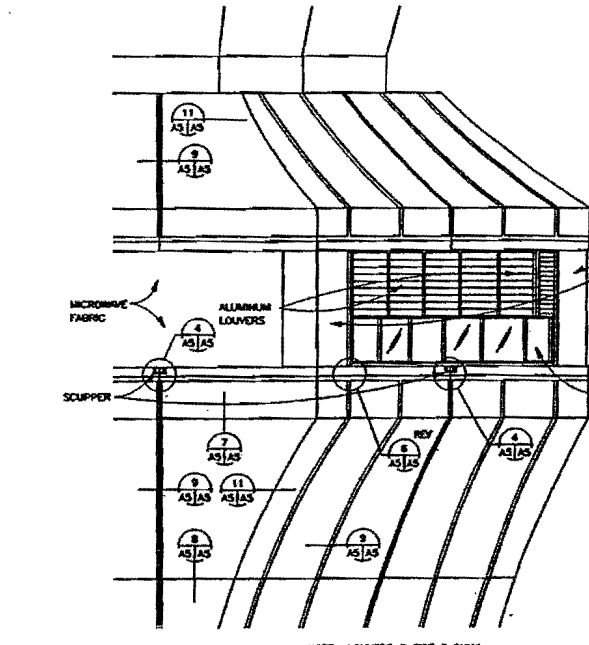

PARTIAL CORNER ELEVATION
SCALE: 1/4" = 1'-0"

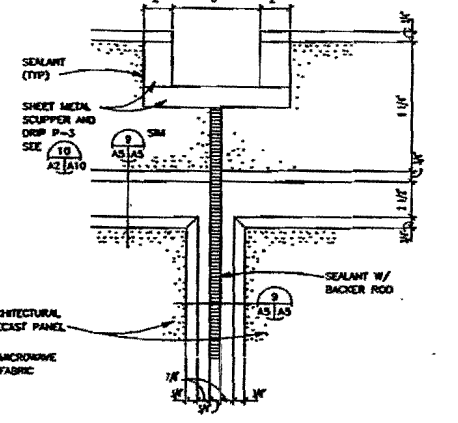

PANEL JT. ELEVATION
SCALE: 3" = 1'-0"

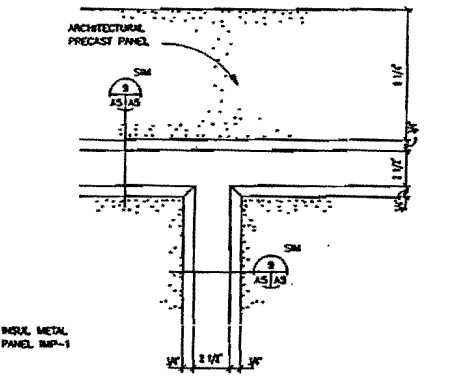

PANEL JT. ELEVATION
SCALE: 3" = 1'-0"

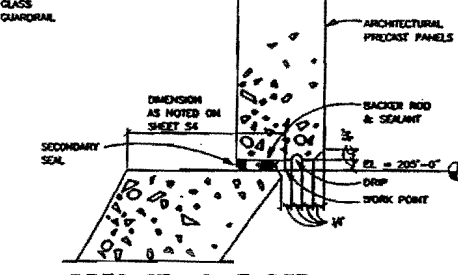

PRECAST JOINT DETAIL
SCALE: 3" = 1'-0"

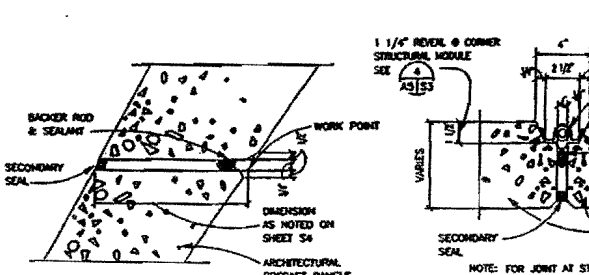

HORIZONTAL JOINT
SCALE: 3" = 1'-0"

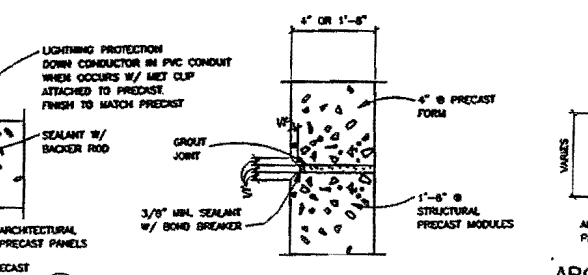

PRECAST JOINT
SCALE: 3" = 1'-0"

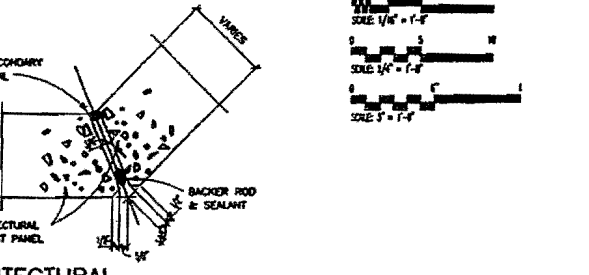

TYP SHAFT JOINT
SCALE: 3" = 1'-0"

| | | | | | | | | | | | | | | | | | | | | | | | | | | |
|--|---------------------------|--|-----------------|---------------------------|-------|-----|-----|--|--|--|--|--|--|--|-------------|-------|----------|-----------------|------------|-------|------|--------------|-------------|------------|-----------|---|
| 0 5 10 20 1/4" = 1'-0" SCALE: 1/4" = 1'-0" 0 5 10 20 1/4" = 1'-0" SCALE: 1/4" = 1'-0" 0 5 10 20 1/4" = 1'-0" SCALE: 1/4" = 1'-0" 0 5 10 20 1/4" = 1'-0" SCALE: 1/4" = 1'-0" | | <table border="1"> <tr> <td>DATE</td> <td>07/04/87 AS-SUBJ (9/1/88)</td> <td>32084</td> <td>2/2</td> </tr> <tr> <td>REV</td> <td></td> <td></td> <td></td> </tr> <tr> <td colspan="4"> DEPARTMENT OF TRANSPORTATION FEDERAL AVIATION ADMINISTRATION CENTRAL REGION KANSAS CITY, MISSOURI MAJOR ACTIVITY LEVEL AIRPORT TRAFFIC CONTROL TOWER ELEVATIONS KANSAS CITY INTERNATIONAL AIRPORT KANSAS CITY, MISSOURI </td> </tr> <tr> <td>DESIGNED BY</td> <td>H & N</td> <td>DRAWN BY</td> <td>John J. Apolito</td> </tr> <tr> <td>CHECKED BY</td> <td>H & N</td> <td>DATE</td> <td>JUNE 1, 1983</td> </tr> <tr> <td>PROJECT NO.</td> <td>CE-7893-AS</td> <td>SHEET NO.</td> <td>1</td> </tr> </table> | DATE | 07/04/87 AS-SUBJ (9/1/88) | 32084 | 2/2 | REV | | | | DEPARTMENT OF TRANSPORTATION FEDERAL AVIATION ADMINISTRATION CENTRAL REGION KANSAS CITY, MISSOURI MAJOR ACTIVITY LEVEL AIRPORT TRAFFIC CONTROL TOWER ELEVATIONS KANSAS CITY INTERNATIONAL AIRPORT KANSAS CITY, MISSOURI | | | | DESIGNED BY | H & N | DRAWN BY | John J. Apolito | CHECKED BY | H & N | DATE | JUNE 1, 1983 | PROJECT NO. | CE-7893-AS | SHEET NO. | 1 |
| DATE | 07/04/87 AS-SUBJ (9/1/88) | 32084 | 2/2 | | | | | | | | | | | | | | | | | | | | | | | |
| REV | | | | | | | | | | | | | | | | | | | | | | | | | | |
| DEPARTMENT OF TRANSPORTATION FEDERAL AVIATION ADMINISTRATION CENTRAL REGION KANSAS CITY, MISSOURI MAJOR ACTIVITY LEVEL AIRPORT TRAFFIC CONTROL TOWER ELEVATIONS KANSAS CITY INTERNATIONAL AIRPORT KANSAS CITY, MISSOURI | | | | | | | | | | | | | | | | | | | | | | | | | | |
| DESIGNED BY | H & N | DRAWN BY | John J. Apolito | | | | | | | | | | | | | | | | | | | | | | | |
| CHECKED BY | H & N | DATE | JUNE 1, 1983 | | | | | | | | | | | | | | | | | | | | | | | |
| PROJECT NO. | CE-7893-AS | SHEET NO. | 1 | | | | | | | | | | | | | | | | | | | | | | | |

HORIZONTAL JOINT
SCALE: 3" = 1'-0"

PRECAST JOINT
SCALE: 3" = 1'-0"

TYP SHAFT JOINT
SCALE: 3" = 1'-0"

ARCHITECTURAL PRECAST CORNER JOINT
SCALE: 3" = 1'-0"

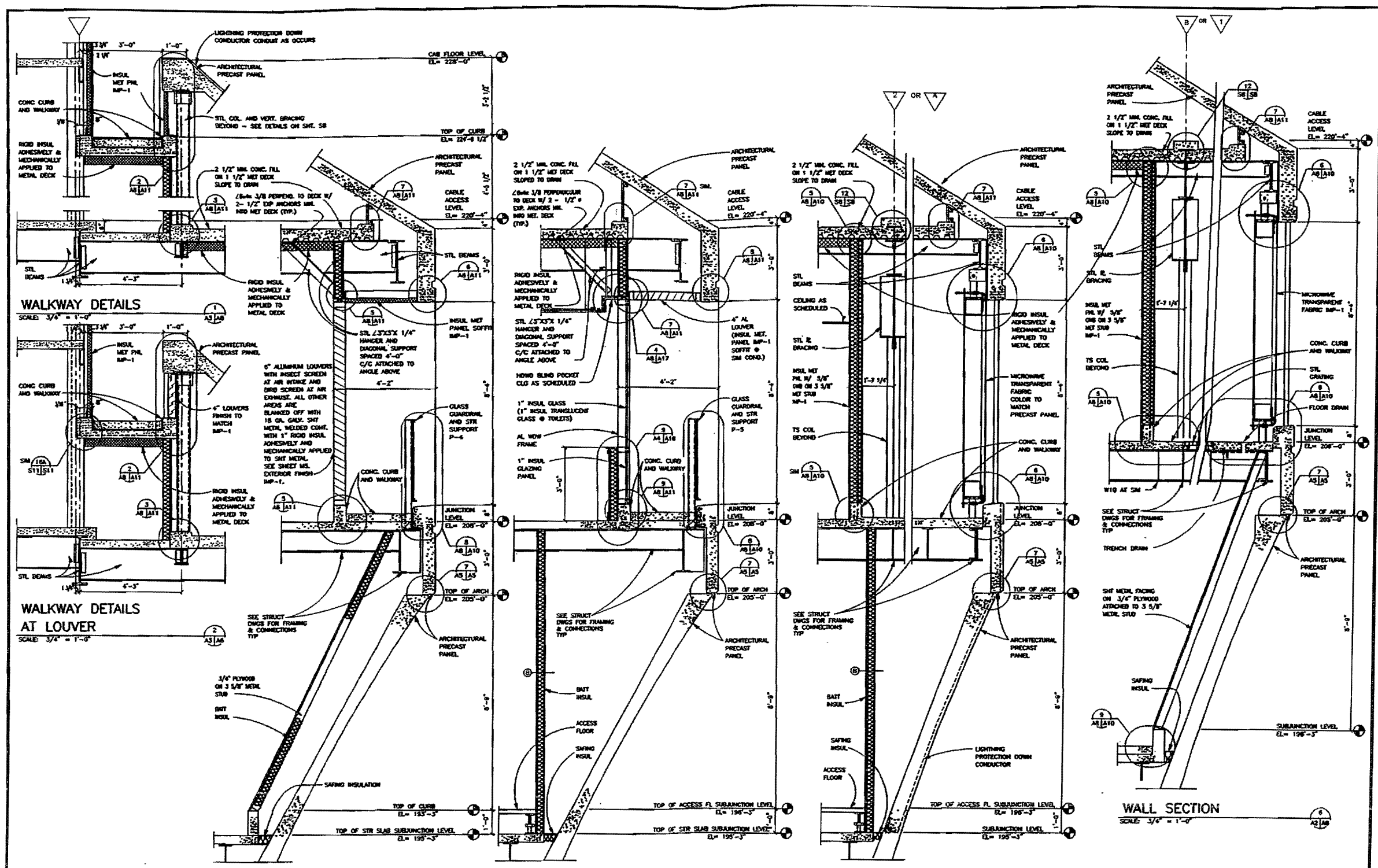

WALKWAY DETAILS
SCALE: 3/4" = 1'-0"

WALKWAY DETAILS AT LOUVER
SCALE: 3/4" = 1'-0"

WALL SECTION
SCALE: 3/4" = 1'-0"

WALL SECTION
SCALE: 3/4" = 1'-0"

WALL SECTION
SCALE: 3/4" = 1'-0"

WALL SECTION
SCALE: 3/4" = 1'-0"

- NOTES:**
1. FOR TYPICAL TOWER SHAFT SECTIONS SEE SHEET AY.
 2. FOR CAB SECTION DRAWING SEE SHEET AG.

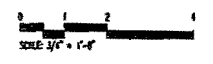

| | | | |
|--|--------------|-------------|------------------|
| 1 07/04/88 AS-BUILT (3/1/88) | | SDWA | PJZ |
| DEPARTMENT OF TRANSPORTATION FEDERAL AVIATION ADMINISTRATION CENTRAL REGION KANSAS CITY, MISSOURI MAJOR ACTIVITY LEVEL AIRPORT TRAFFIC CONTROL TOWER | | | |
| WALL SECTION | | | |
| KANSAS CITY INTERNATIONAL AIRPORT KANSAS CITY, MISSOURI | | | |
| DESIGNED BY | H & N | APPROVED BY | John J. Spaulden |
| DRAWN BY | H & N | CHECKED BY | John J. Spaulden |
| DATE | MAY 1, 1988 | PROJECT NO. | 7893-AS |
| SCALE | 3/4" = 1'-0" | SHEET NO. | 1 |
| HOLMES & NARVER 348 TOWN & COUNTRY ROAD DANVILLE, CALIFORNIA 94501 | | CE-7893-AS | |

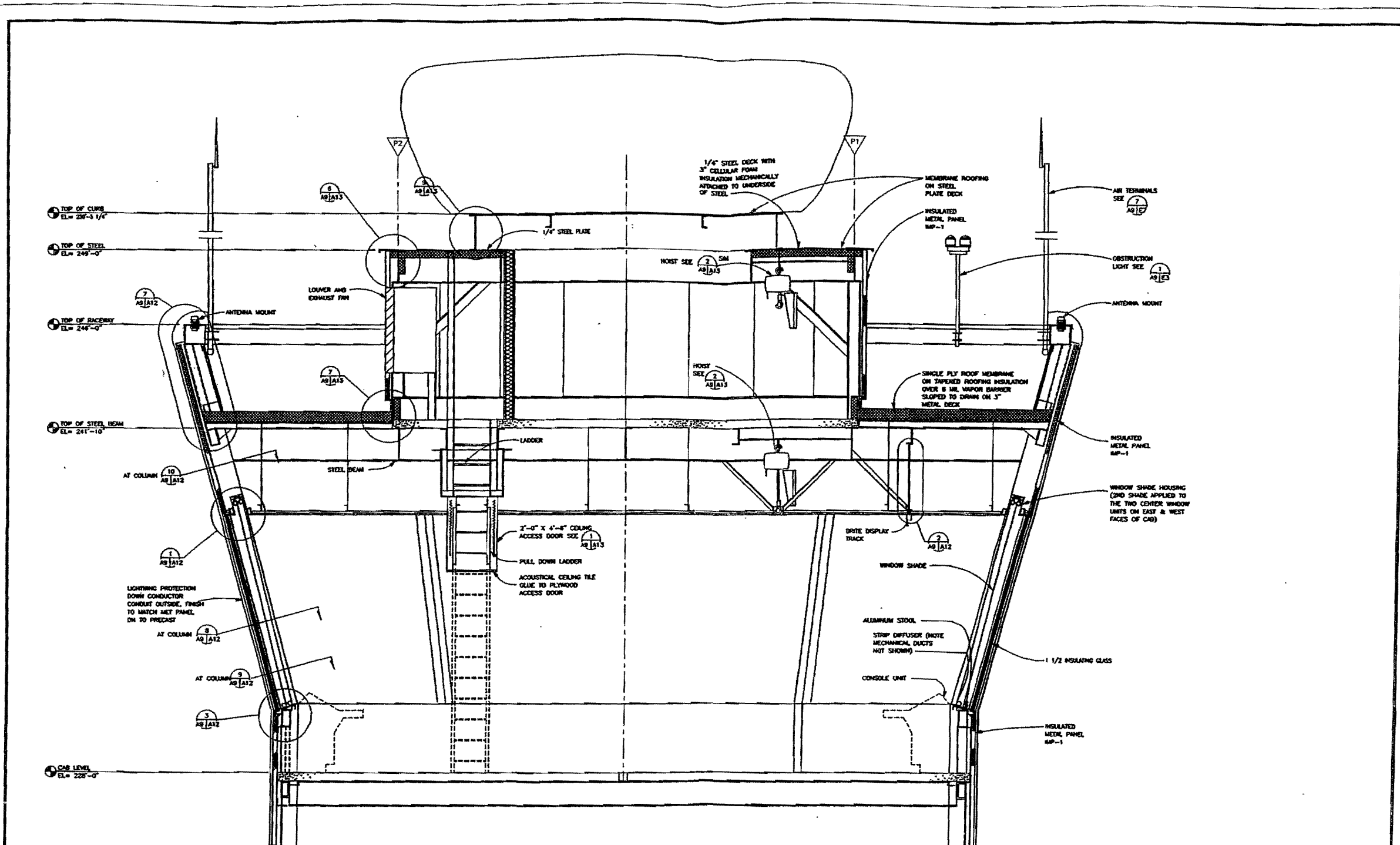

CAB SECTION
SCALE: 3/4" = 1'-0"

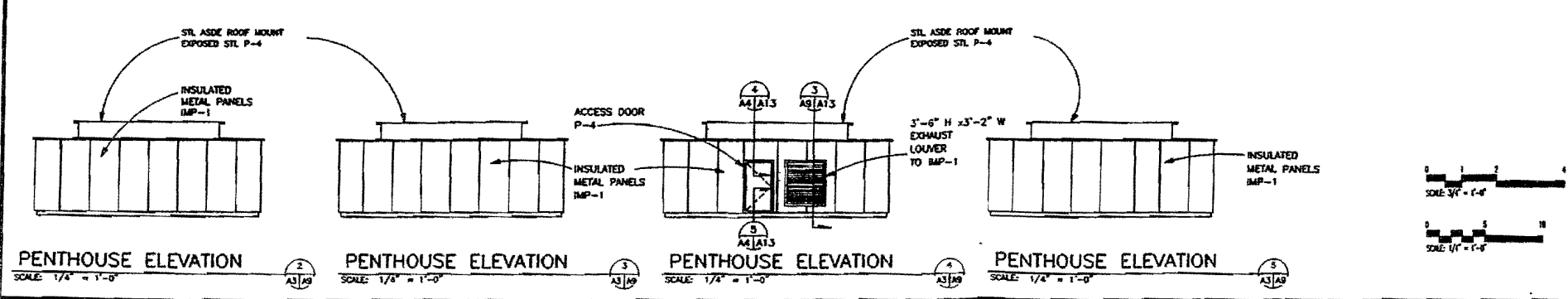

| | | | |
|---|---|-------------|-----------------|
| 1 02/04/89 AS-SUALT (S/L/T/W) | | SIZE | P22 |
| REV. | DATE | DESCRIPTION | BY |
| DEPARTMENT OF TRANSPORTATION FEDERAL AVIATION ADMINISTRATION CENTRAL REGION KANSAS CITY, MISSOURI MAJOR ACTIVITY LEVEL AIRPORT TRAFFIC CONTROL TOWER CAB SECTION KANSAS CITY INTERNATIONAL AIRPORT KANSAS CITY, MISSOURI | | | |
| DESIGNED BY | ALBERT FACCHINI ENGINEERS 601 EAST 15TH STREET KANSAS CITY, MISSOURI 64108 | DRAWN BY | John J. Apolito |
| CHECKED BY | | DATE | APR 1, 1983 |
| SHEET NO. 1 OF 1 CE-7893-A9 | | | |

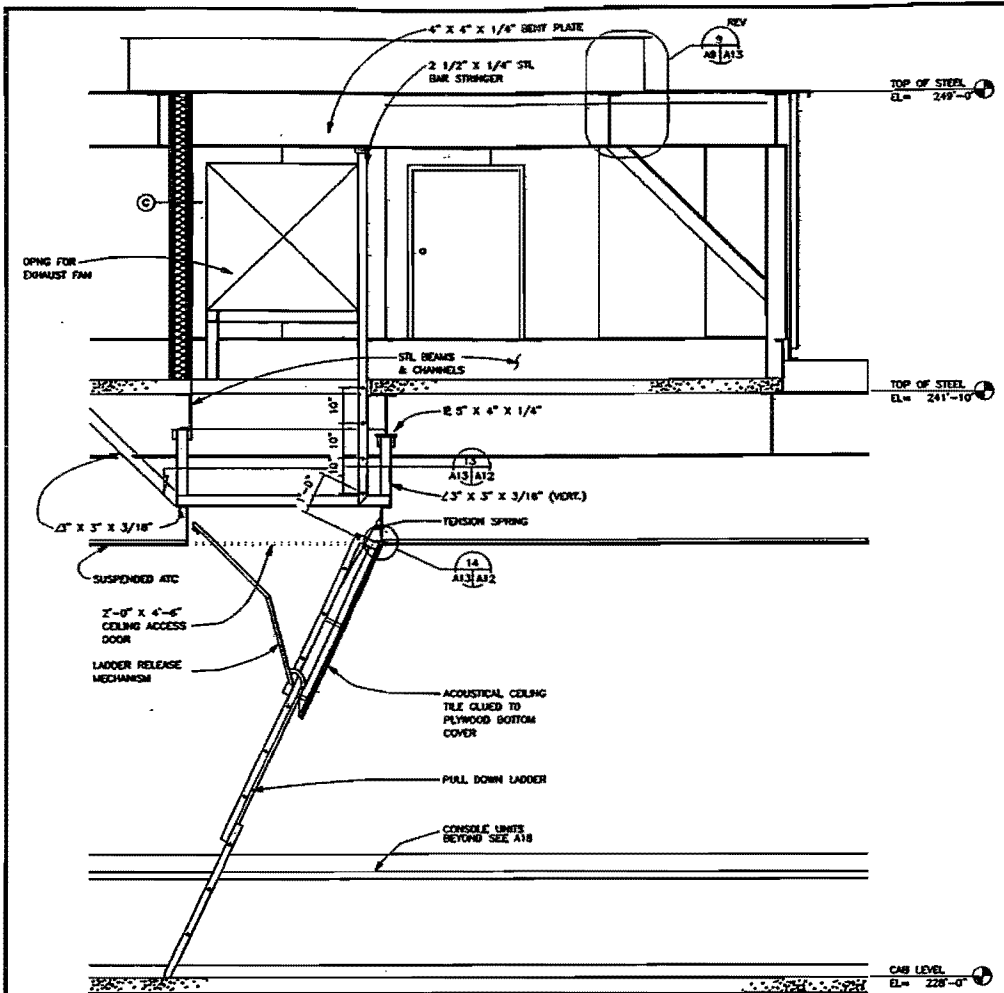

SECTION
SCALE: 3/4" = 1'-0"

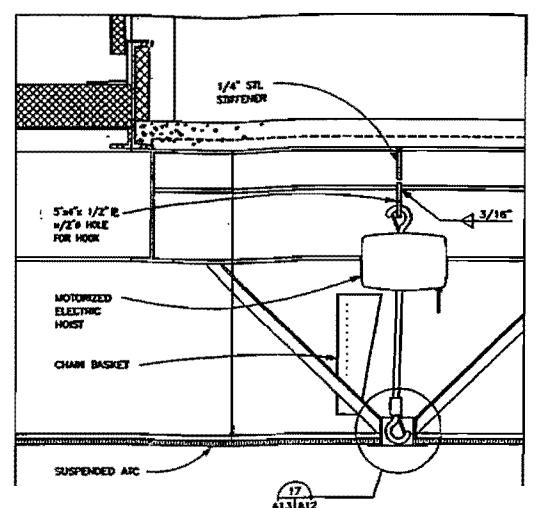

HOIST DETAIL
SCALE: 1 1/2" = 1'-0"

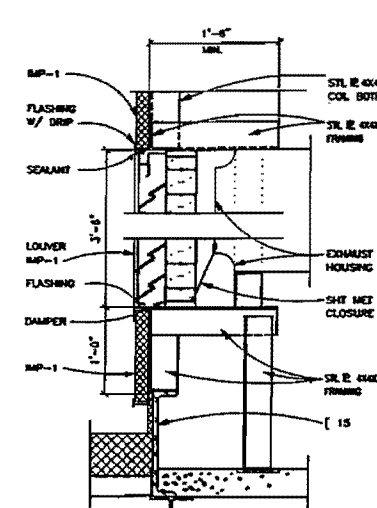

EXHAUST FAN DETAIL
SCALE: 1 1/2" = 1'-0"

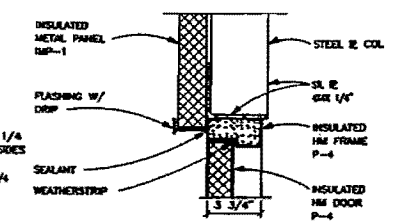

HEAD/JAMB DETAIL
SCALE: 3" = 1'-0"

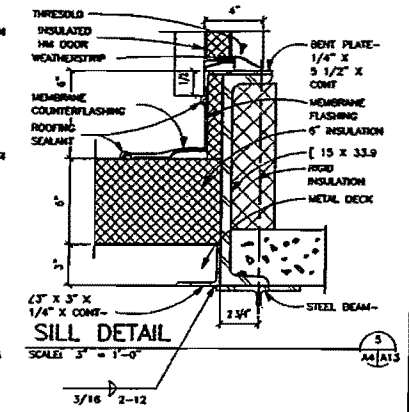

SILL DETAIL
SCALE: 3" = 1'-0"

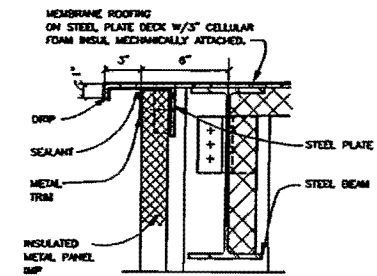

ROOF DETAIL
SCALE: 3" = 1'-0"

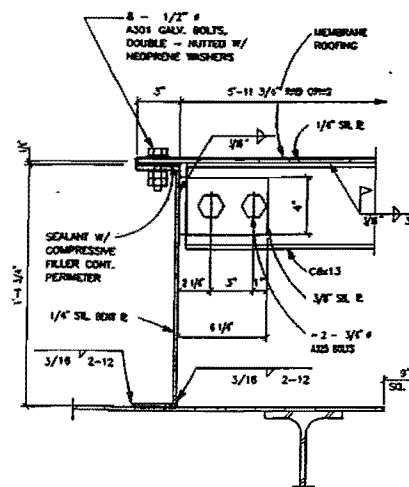

FLASHING DETAIL
SCALE: 3" = 1'-0"

PENTHOUSE/ASDE ROOF DETAIL
SCALE: 3" = 1'-0"

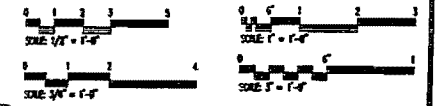

| | |
|---|--|
| DEPARTMENT OF TRANSPORTATION FEDERAL AVIATION ADMINISTRATION CENTRAL REGION MAJOR ACTIVITY LEVEL AIRPORT TRAFFIC CONTROL TOWER CAB PENTHOUSE DETAILS KANSAS CITY INTERNATIONAL AIRPORT KANSAS CITY, MISSOURI | |
| PROJECT NO. 7893-A13 SHEET NO. 02 DATE: JUNE 1, 1993 | DRAWN BY: Andrew J. Holmbeck CHECKED BY: Andrew J. Holmbeck DATE: JUNE 1, 1993 |

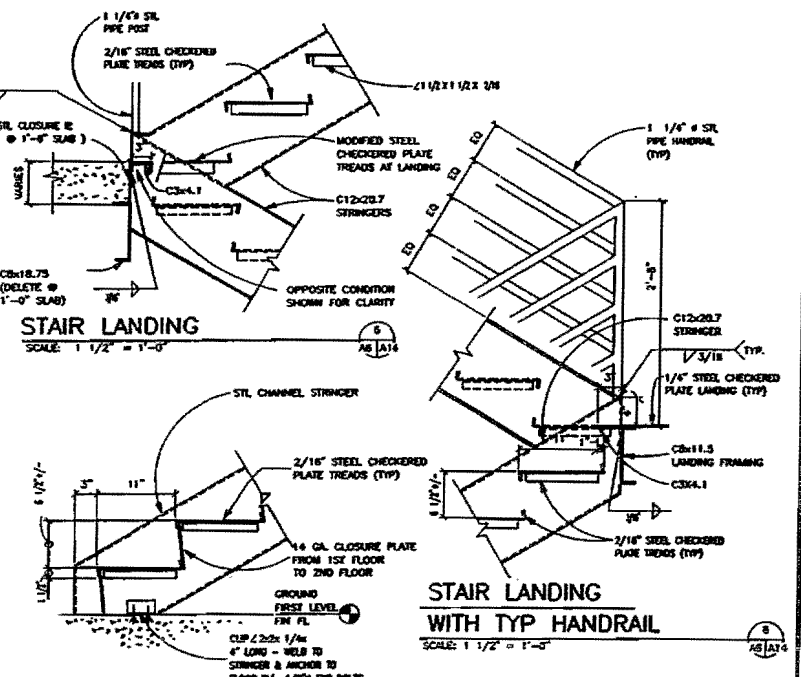
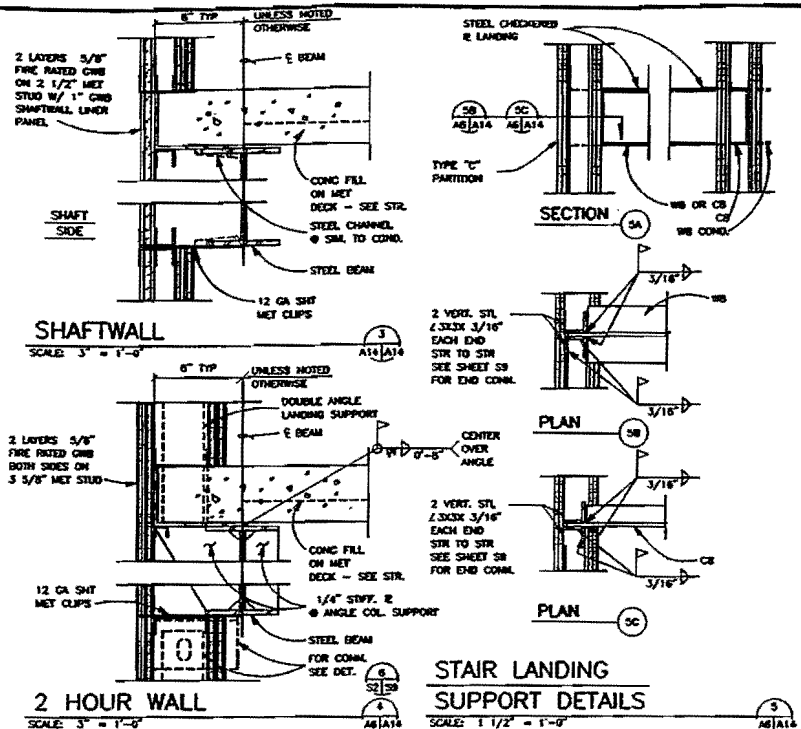
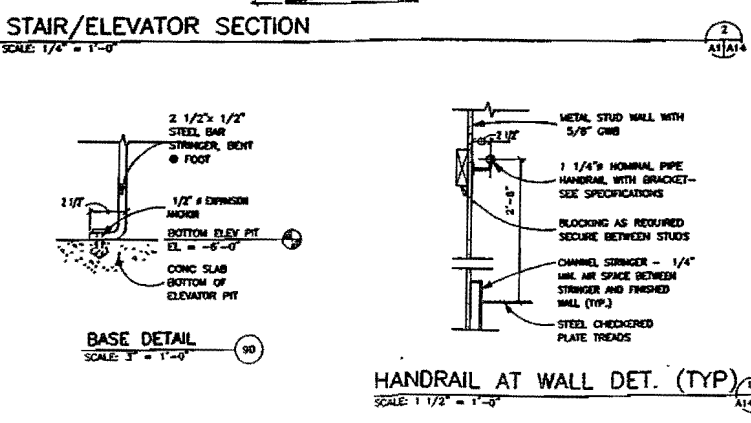
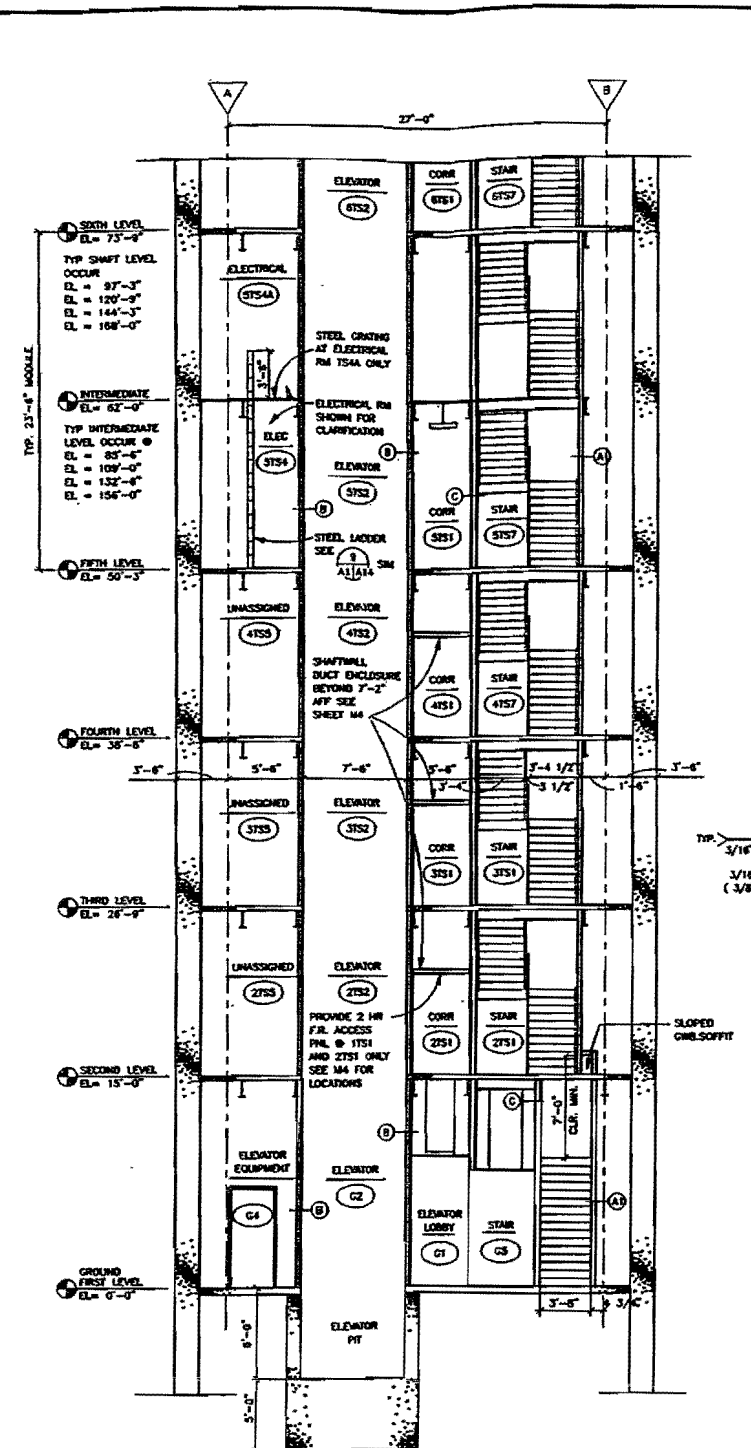
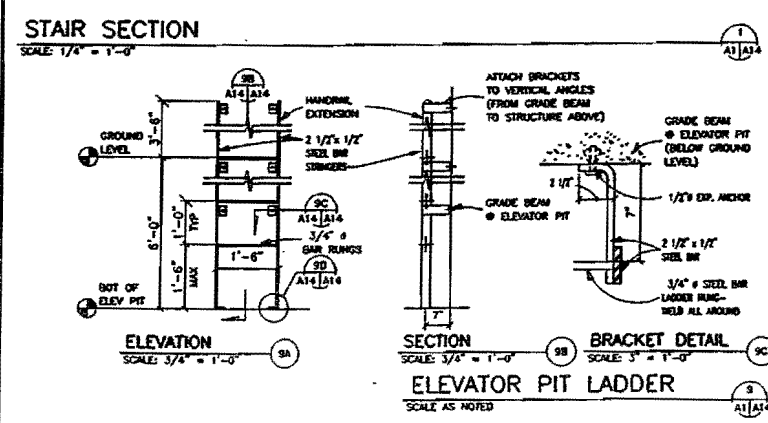
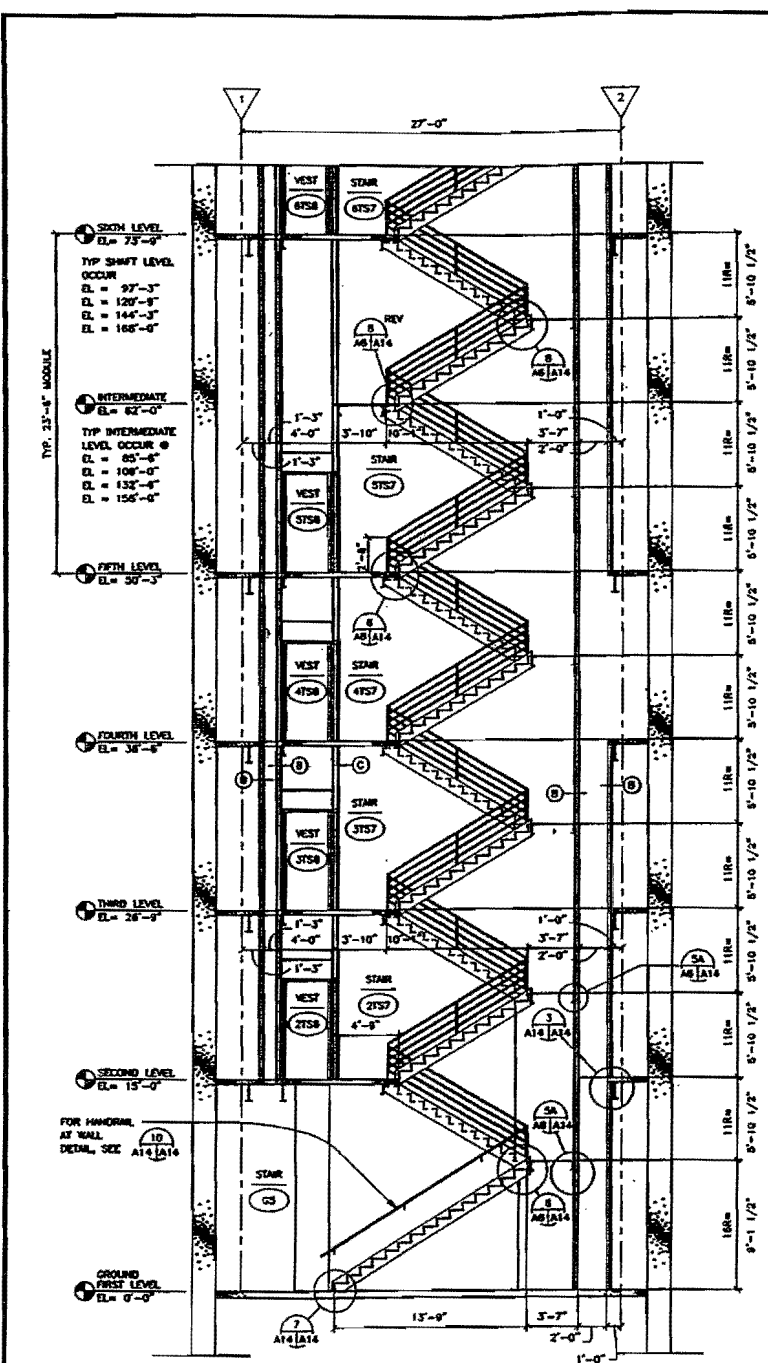

| | |
|--|--|
| DEPARTMENT OF TRANSPORTATION FEDERAL AVIATION ADMINISTRATION CENTRAL REGION KANSAS CITY, MISSOURI MAJOR ACTIVITY LEVEL AIRPORT TRAFFIC CONTROL TOWER STAIR AND ELEVATOR DETAILS KANSAS CITY INTERNATIONAL AIRPORT KANSAS CITY, MISSOURI | |
| PROJECT NO. 07/04/97 AS-BUILD (9/1/96) DATE 07/04/97 DRAWN BY J. J. [unreadable] CHECKED BY J. J. [unreadable] | SCALE: 1/4" = 1'-0" SCALE: 3/4" = 1'-0" SCALE: 1 1/2" = 1'-0" SCALE: 3" = 1'-0" |
| DESIGNED BY: ALBERT FACILITIES DIVISION 600 EAST 15TH STREET KANSAS CITY, MISSOURI 64108 | DRAWN BY: J. J. [unreadable] CHECKED BY: J. J. [unreadable] DATE: JUNE 1, 1993 |
| PROJECT FILE NO. CE-7893-A14-S0-R1.DWG DRAWN BY: J. J. [unreadable] | SHEET NO. 1 OF 1 |

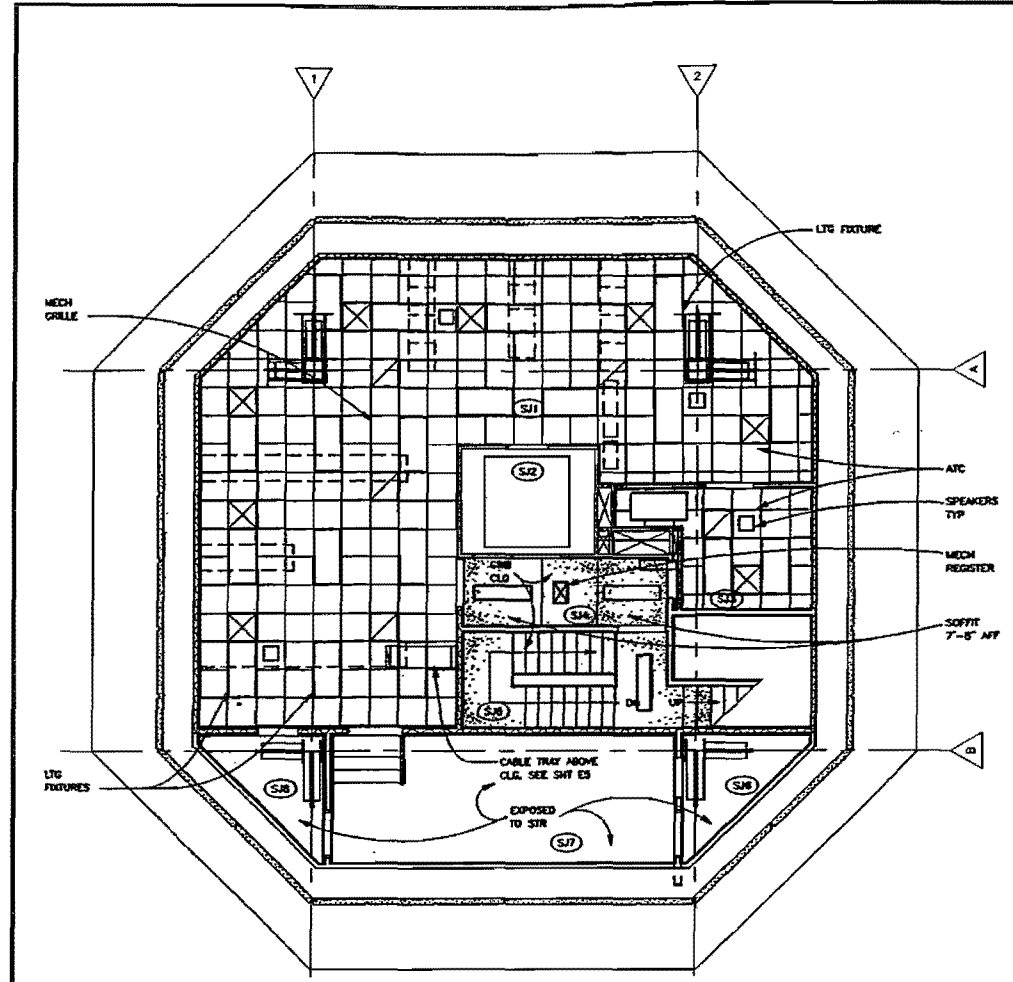

SUBJUNCTION LEVEL REFLECTED CEILING PLAN

SCALE: 1/4" = 1'-0"

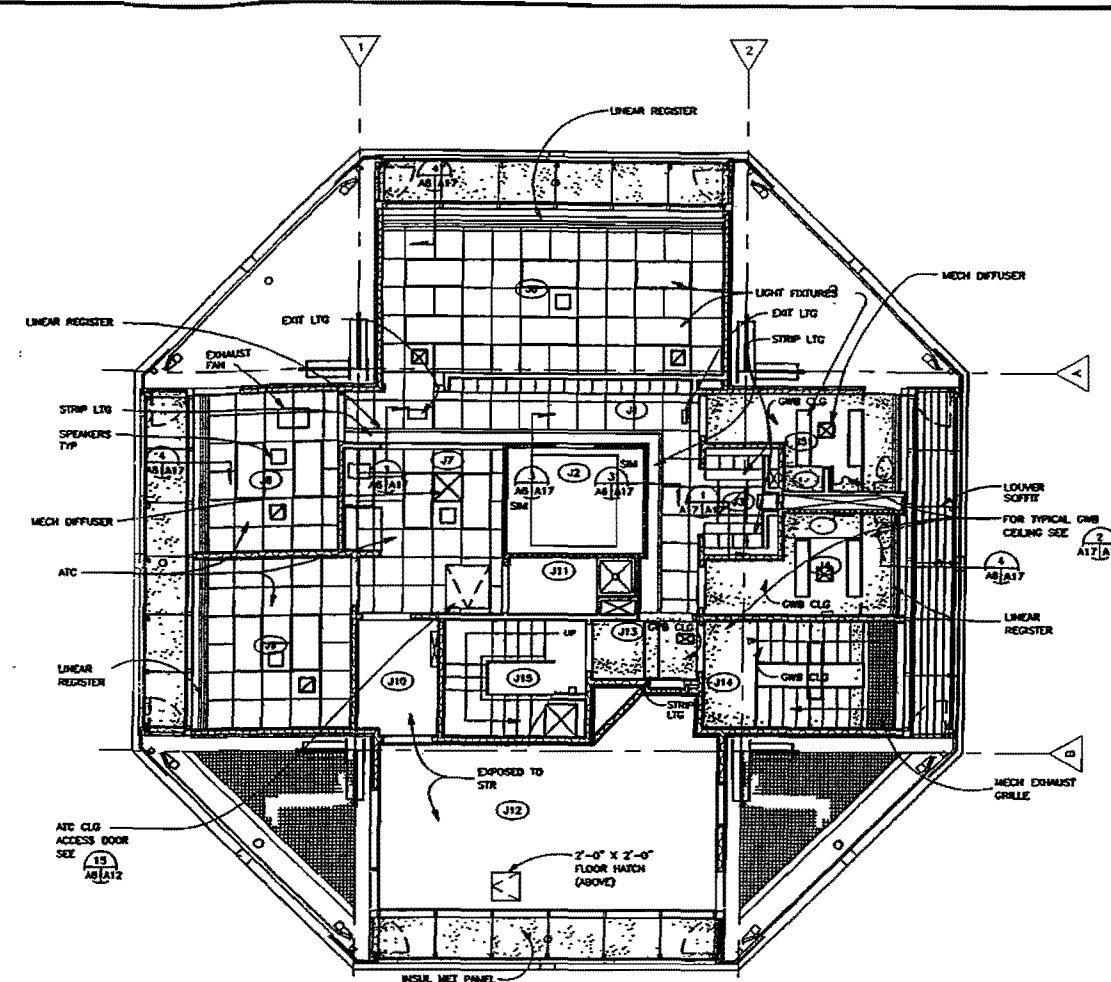

JUNCTION LEVEL REFLECTED CEILING PLAN

SCALE: 1/4" = 1'-0"

| ROOM SCHEDULE | |
|---------------|----------------------|
| NO. | NAME |
| S21 | ELECTRONIC EQUIPMENT |
| S22 | ELEVATOR |
| S23 | SHOP |
| S24 | VESTIBULE |
| S25 | STAIR |
| S26 | AIR SHFT |
| S27 | MECHANICAL ROOM |
| S28 | AIR SHFT |
| J1 | CORRIDOR |
| J2 | ELEVATOR |
| J3 | LOCKER |
| J4 | WOMEN |
| J5 | MEN |
| J6 | BREAKROOM |
| J7 | KITCHENETTE |
| J8 | OFFICE |
| J9 | OPERATIONAL SUPPORT |
| J10 | VESTIBULE |
| J11 | CLEANUP |
| J12 | MECHANICAL |
| J13 | MECHANICAL |
| J14 | STAIR |
| J15 | CAB STAIR |

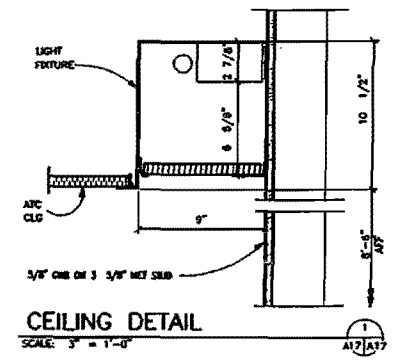

CEILING DETAIL

SCALE: 3" = 1'-0"

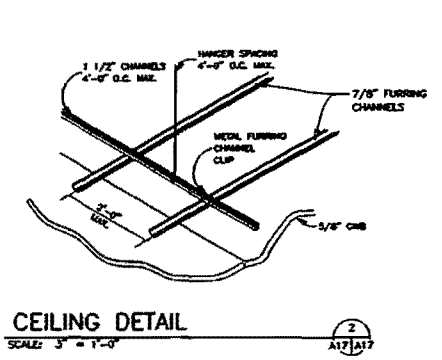

CEILING DETAIL

SCALE: 3" = 1'-0"

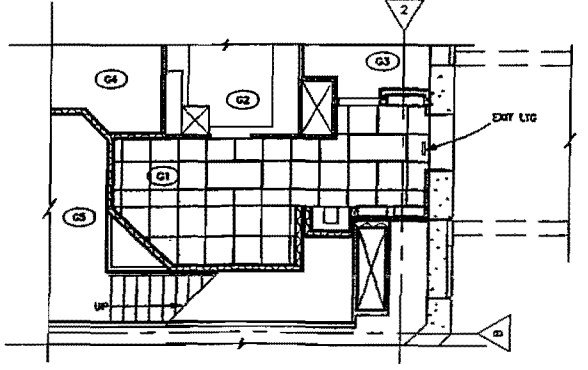

PARTIAL GROUND LEVEL REFLECTED CEILING PLAN

SCALE: 1/4" = 1'-0"

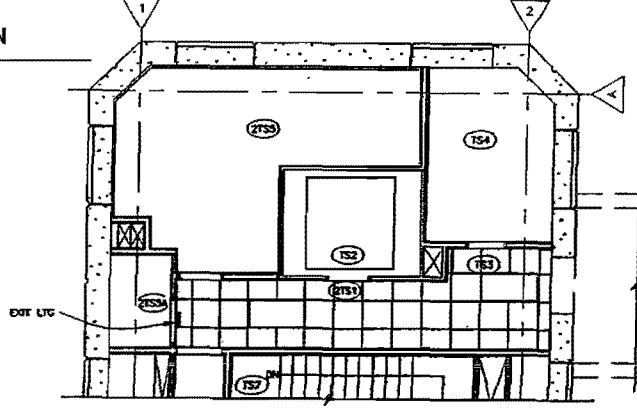

PARTIAL SECOND LEVEL REFLECTED CEILING PLAN

SCALE: 1/4" = 1'-0"

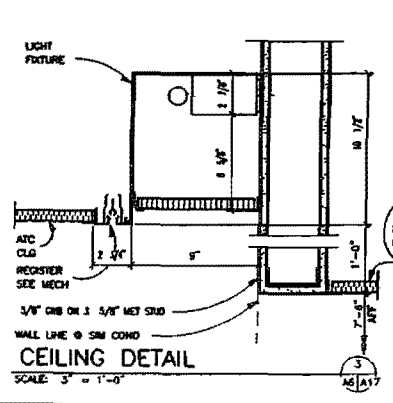

CEILING DETAIL

SCALE: 3" = 1'-0"

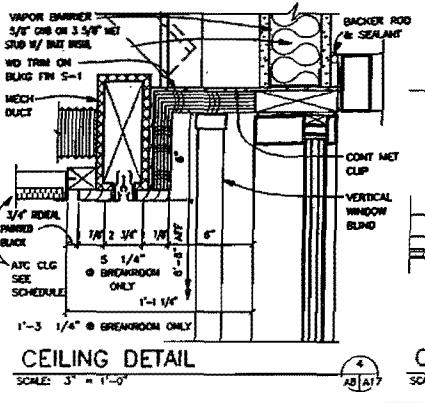

CEILING DETAIL

SCALE: 3" = 1'-0"

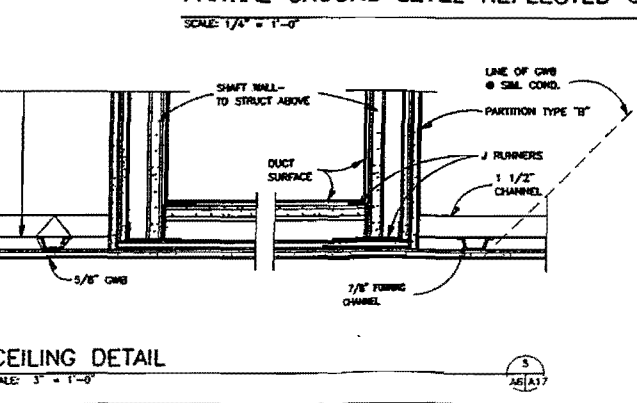

CEILING DETAIL

SCALE: 3" = 1'-0"

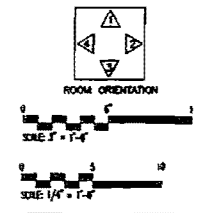

1 07/04/87 AS-BUILT (8/1/86) 52068 PJJ

DEPARTMENT OF TRANSPORTATION
FEDERAL AVIATION ADMINISTRATION
CENTRAL REGION KANSAS CITY, MISSOURI
MAJOR ACTIVITY LEVEL AIRPORT TRAFFIC CONTROL TOWER
REFLECTED CEILING PLANS AND DETAILS
KANSAS CITY INTERNATIONAL AIRPORT
KANSAS CITY, MISSOURI

DESIGNED BY: H & N
CHECKED BY: H & N
DATE: 07/04/87

SCALE: 1/4" = 1'-0"

DATE: JUNE 1, 1983

CEILING PLAN REFLECTED CEILING PLAN

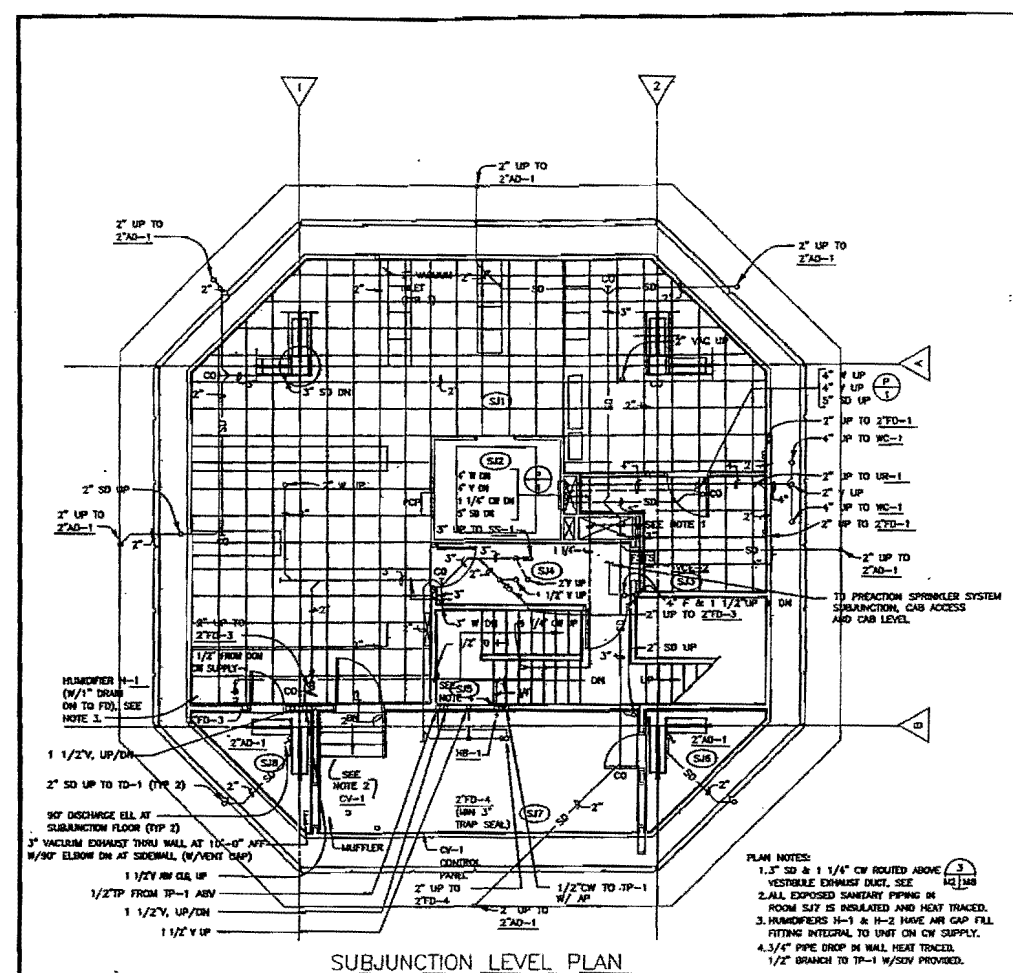

SUBJUNCTION LEVEL PLAN
SCALE: 1/4" = 1'-0"

PLAN NOTES:
 1. 3" SD & 1 1/4" CW SIZED ABOVE VESTIBULE EXHAUST DUCT. SEE 11123.
 2. ALL EXPOSED SANITARY PIPING IN ROOM SJ7 IS INSULATED AND HEAT TRACED.
 3. HUBROFFERS H-1 & H-2 HAVE AIR GAP FILL FITTING INTERNAL TO UNIT ON CW SUPPLY.
 4. 3/4" PIPE DROP IN WALL HEAT TRACED. 1/2" BRANCH TO TP-1 W/SOV PROVIDED.

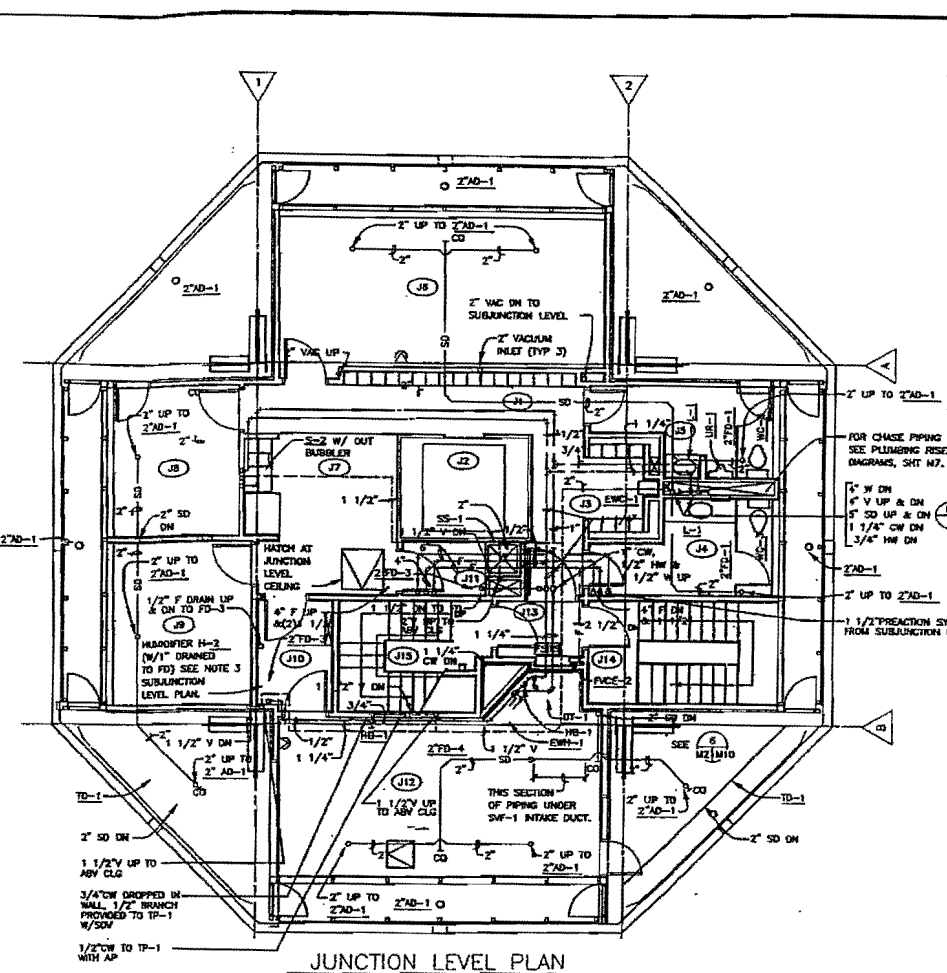

JUNCTION LEVEL PLAN
SCALE: 1/4" = 1'-0"

| ROOM SCHEDULE | |
|---------------|----------------------|
| NO. | NAME |
| S01 | ELECTRONIC EQUIPMENT |
| S02 | ELEVATOR |
| S03 | SHOP |
| S04 | VESTIBULE |
| S05 | STAIR |
| S06 | AIR SHAFT |
| S07 | CONDENSED PLENUM |
| S08 | AIR SHAFT |
| J01 | CORRIDOR |
| J02 | ELEVATOR |
| J03 | LOCKER |
| J04 | WOMEN |
| J05 | MEN |
| J06 | BREAKROOM |
| J07 | KITCHENETTE |
| J08 | OFFICE |
| J09 | OPERATIONAL SUPPORT |
| J10 | VESTIBULE |
| J11 | CLEANUP |
| J12 | MECHANICAL |
| J13 | VESTIBULE |
| J14 | STAIR |
| J15 | CAB STAIR |
| 111S1 | CORRIDOR |
| 111S2 | ELEVATOR |
| 111S3 | MECHANICAL |
| 111S4 | ELECTRICAL |
| 111S5 | BATTERY |
| 111S5A | UNASSIGNED |
| 111S6 | VESTIBULE |
| 111S7 | STAIR |

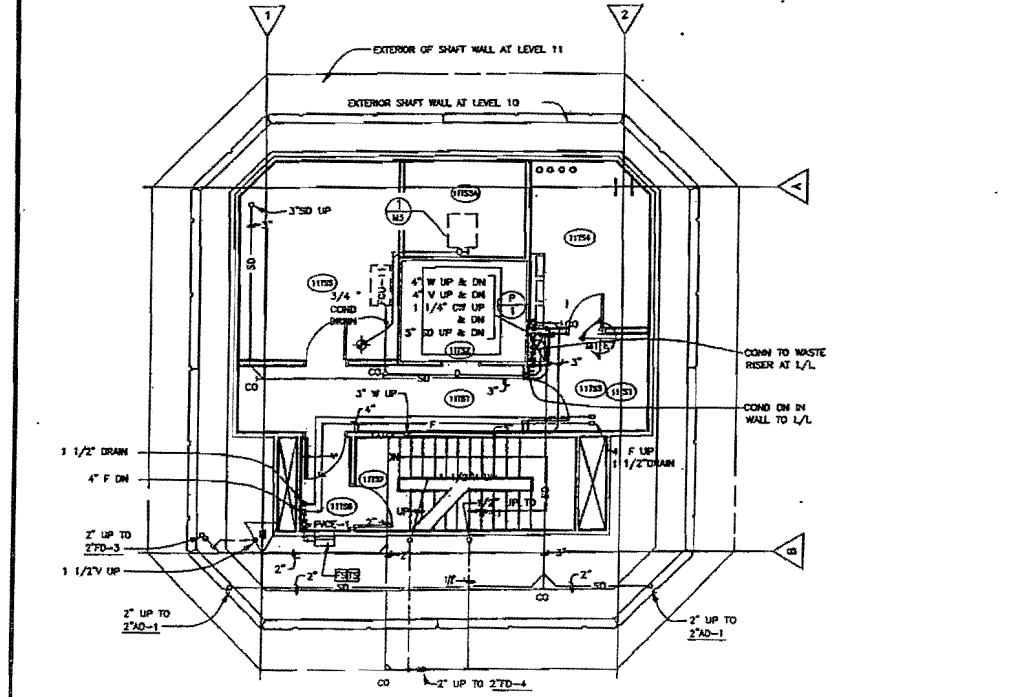

LEVEL 11 SHAFT PLAN
SCALE: 1/4" = 1'-0"

| | | | | |
|---|----------|--------------------------------------|-------|-----|
| 3 | 08/21/81 | PIPE REPLACEMENT AS BUILT (08/21/81) | 17148 | 255 |
| 2 | 05/22/80 | ADD FINE COIL FOR PEN REPLACEMENT | 17148 | 255 |
| 1 | 07/04/79 | AS-BUILT (7/1/79) | 52084 | 248 |

DEPARTMENT OF TRANSPORTATION
 FEDERAL AVIATION ADMINISTRATION
 CENTRAL REGION
 MAJOR ACTIVITY LEVEL AIRPORT TRAFFIC CONTROL TOWER
 PLUMBING PLANS
 KANSAS CITY INTERNATIONAL AIRPORT
 KANSAS CITY, MISSOURI

DESIGNED BY: ARNEY FACILITIES DIVISION
 600 EAST 12TH STREET
 KANSAS CITY, MISSOURI 64108

DRAWN BY: Andrew J. Melnick
 CHECKED BY: Andrew J. Melnick
 DATE: JUNE 1, 1983

PROJECT NO: CE_MCI_7883_M07_S03_E.DWG
 SHEET NO: CE-E-7883-M2

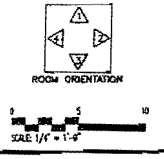

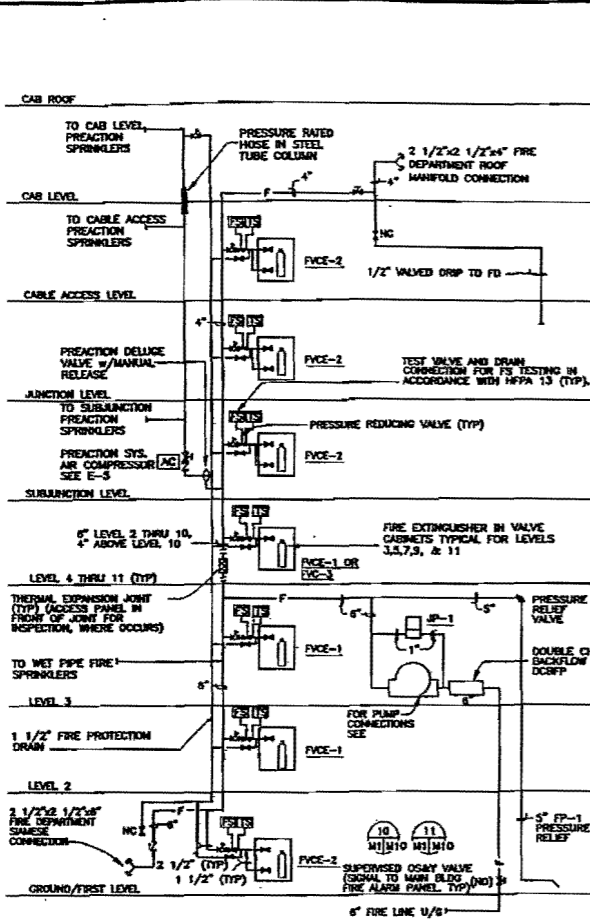

STANDPIPE RISER DIAGRAM

NO SCALE

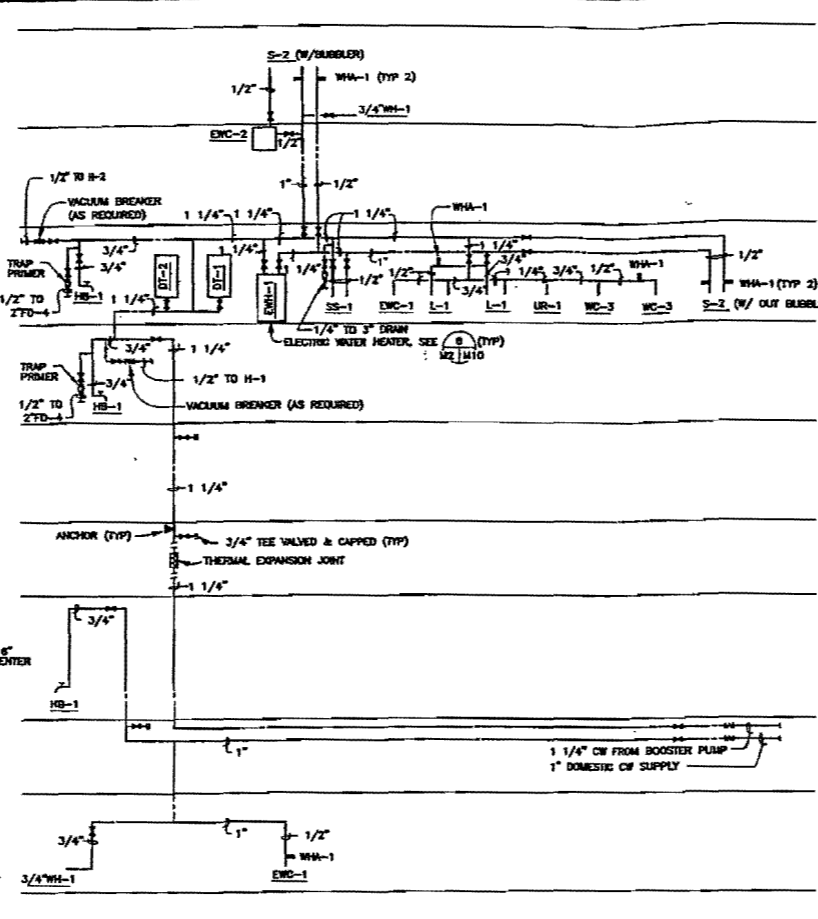

DOMESTIC WATER RISER DIAGRAM

NO SCALE

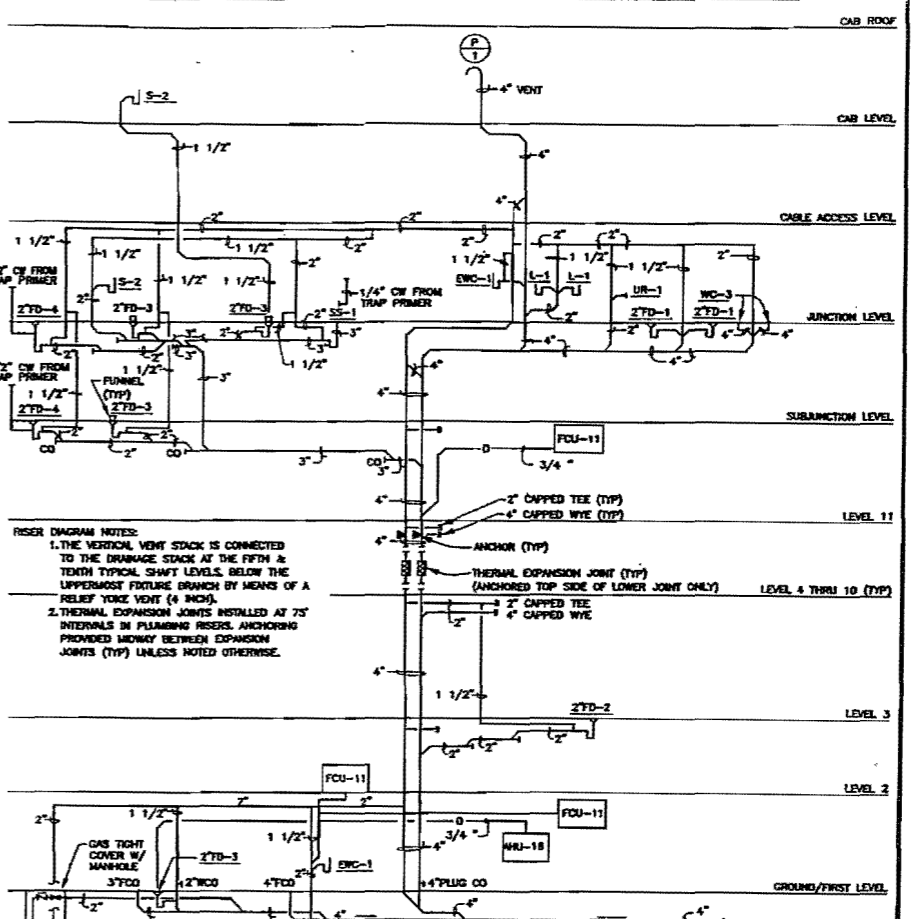

WASTE AND VENT RISER DIAGRAM

NO SCALE

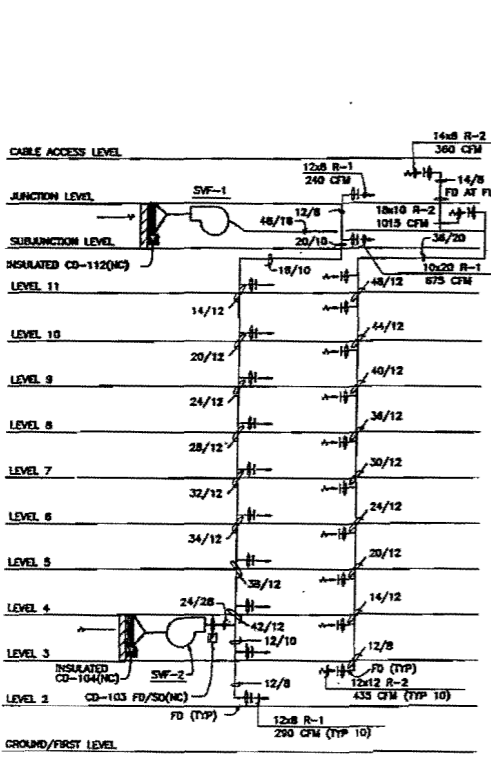

VESTIBULE SMOKE CONTROL RISER

NO SCALE

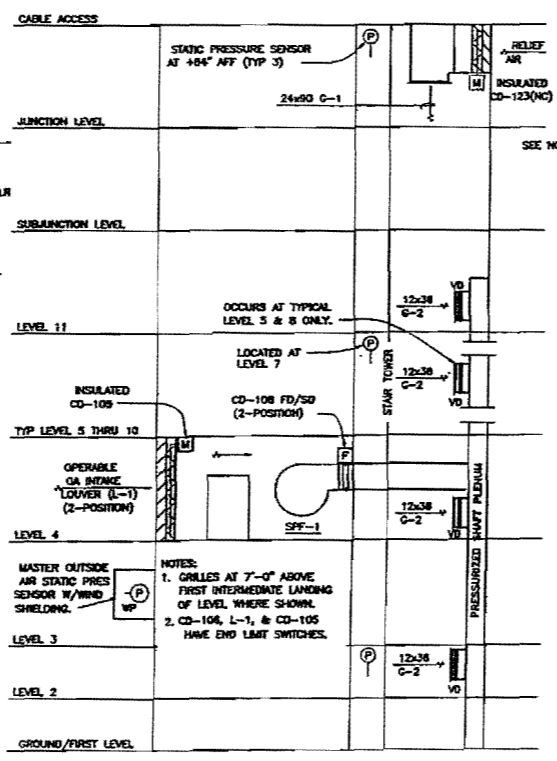

STAIRWELL PRESSURIZATION RISER DIAGRAM

NO SCALE

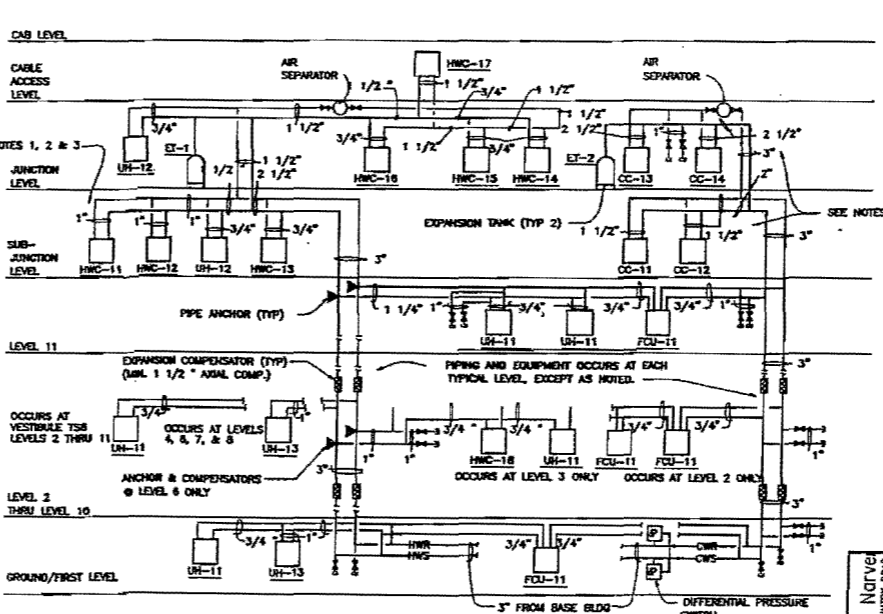

HOT WATER & CHILLED WATER RISER DIAGRAMS

NO SCALE

- NOTES:
- SEE DRAWING CE-E-7893-45 HMC PUMPS (SUBJUNCTION AND JUNCTION LEVEL PLANS) FOR LOCATION OF AIR FLOWING UNIT COIL.
 - SEE DRAWING CE-E-7893-410, DETAIL 10, WATER COIL.
 - THIS DRAWING PROVIDES PIPING SIZE INFORMATION.

| NO. | DATE | BY | DESCRIPTION | APPROVED |
|-----|----------|---------------------------------|-------------|----------|
| 1 | 02/24/97 | AS-BUILT (S/AV) STAIR SILE PUMP | 2741A | ASB |
| 2 | 11/20/98 | STAIR SILE PUMP | 5047A | ASB |
| 3 | 02/24/97 | AS-BUILT (S/AV) STAIR SILE PUMP | 2741A | ASB |

DEPARTMENT OF TRANSPORTATION
 FEDERAL AVIATION ADMINISTRATION
 CENTRAL REGION
 KANSAS CITY, MISSOURI
 MAJOR ACTIVITY LEVEL AIRPORT TRAFFIC CONTROL TOWER
RISER DIAGRAMS
 KANSAS CITY INTERNATIONAL AIRPORT
 KANSAS CITY, MISSOURI

DRAWN BY: Larry R. Janssen
 CHECKED BY: Andrew J. Holcomb
 DATE: JUNE 1, 1993
 SHEET NO. 3

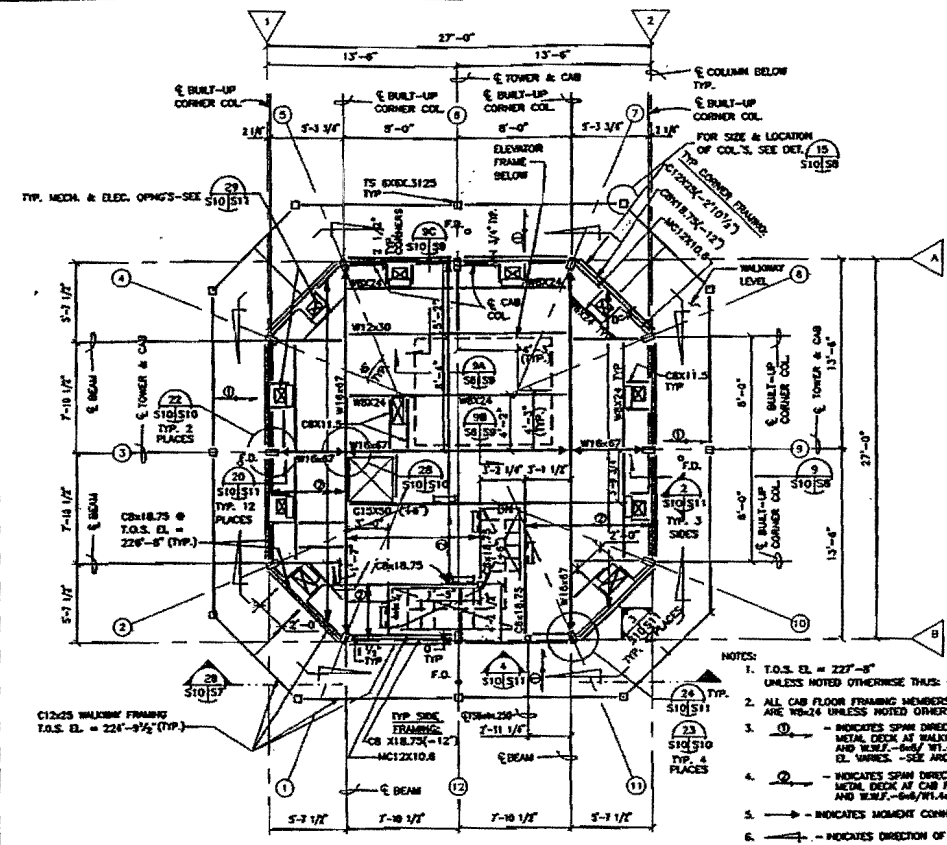

CAB FLOOR AND WALKWAY FRAMING PLAN
SCALE: 1/4" = 1'-0"

- NOTES:
1. T.O.S. EL. = 227'-8" UNLESS NOTED OTHERWISE THUS: (+4")
 2. ALL CAB FLOOR FRAMING MEMBERS ARE W8x24 UNLESS NOTED OTHERWISE
 3. (Symbol) - INDICATES SPAN DIRECTION OF 1 1/2" 20 GAGE METAL DECK AT WALKWAY W/ 2 1/2" CONC. FILL AND W8x24 W/ 1" CONC. FILL. TOP OF CONC. EL. SURF. - SEE ARCH.
 4. (Symbol) - INDICATES SPAN DIRECTION OF 1 1/2" 20 GAGE METAL DECK AT CAB FLOOR W/ 2 1/2" CONC. FILL AND W8x24 W/ 1" CONC. FILL.
 5. (Symbol) - INDICATES MOMENT CONNECTION
 6. (Symbol) - INDICATES DIRECTION OF 1/4" P.L. SLOPE
 7. SEE DETAIL 8/58 FOR FRAMING OF FLOOR OPENINGS
 8. SEE SHEET S1 FOR CAB COLUMN NOTES AND OTHER STRUCTURAL NOTES.
 9. FOR TYPICAL BEAM CONNECTION DETAIL, SEE (Symbol)

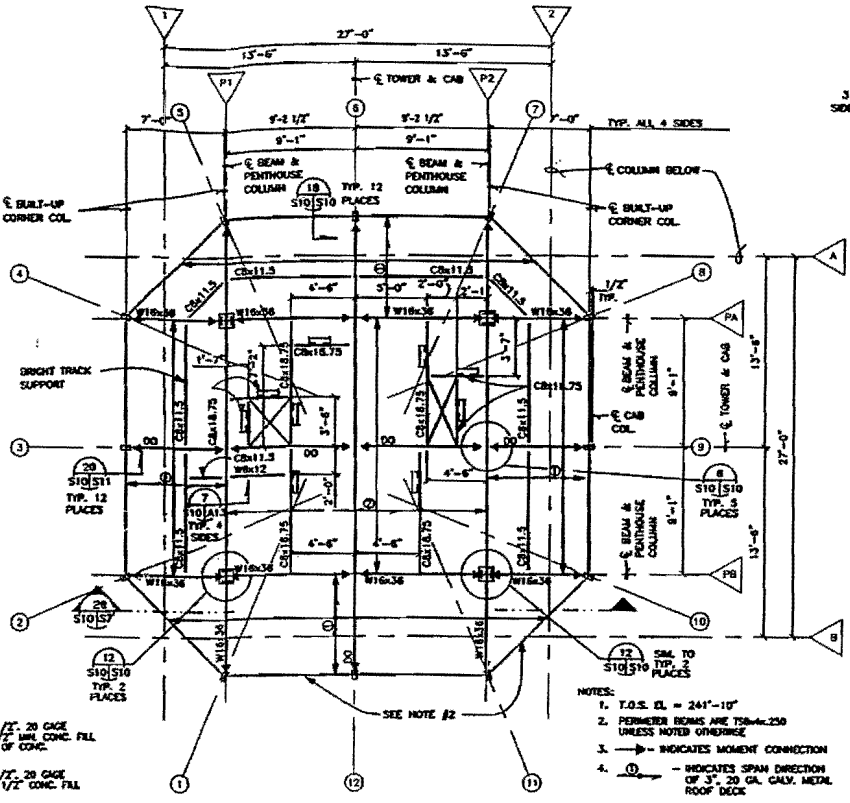

CAB ROOF FRAMING PLAN
SCALE: 1/4" = 1'-0"

- NOTES:
1. T.O.S. EL. = 241'-10"
 2. PERIMETER BEAMS ARE W8x24 UNLESS NOTED OTHERWISE
 3. (Symbol) - INDICATES MOMENT CONNECTION
 4. (Symbol) - INDICATES SPAN DIRECTION OF 3" 20 GAGE METAL ROOF DECK
 5. (Symbol) - INDICATES SPAN DIRECTION OF 1 1/2" 20 GAGE METAL DECK W/ 2 1/2" CONC. FILL & W8x24 W/ 1" CONC. FILL.
 6. SEE SHEET S1 FOR CAB COLUMN NOTES AND OTHER STRUCTURAL NOTES.
 7. FOR TYPICAL BEAM CONNECTION DETAIL, SEE (Symbol)

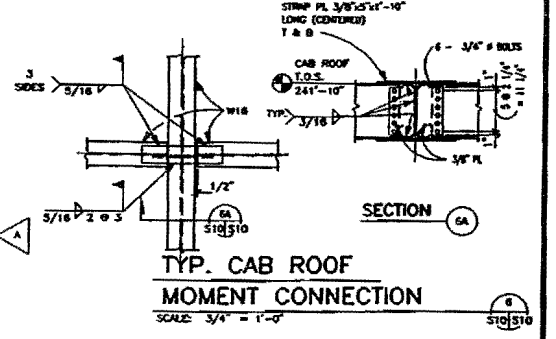

TYP. CAB ROOF MOMENT CONNECTION
SCALE: 3/4" = 1'-0"

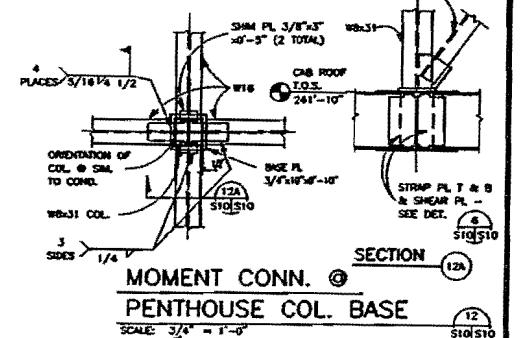

MOMENT CONN. @ PENTHOUSE COL. BASE
SCALE: 3/4" = 1'-0"

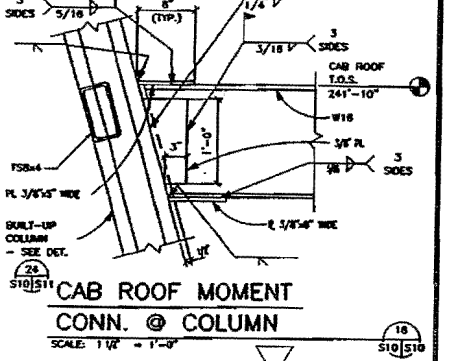

CAB ROOF MOMENT CONN. @ COLUMN
SCALE: 1 1/2" = 1'-0"

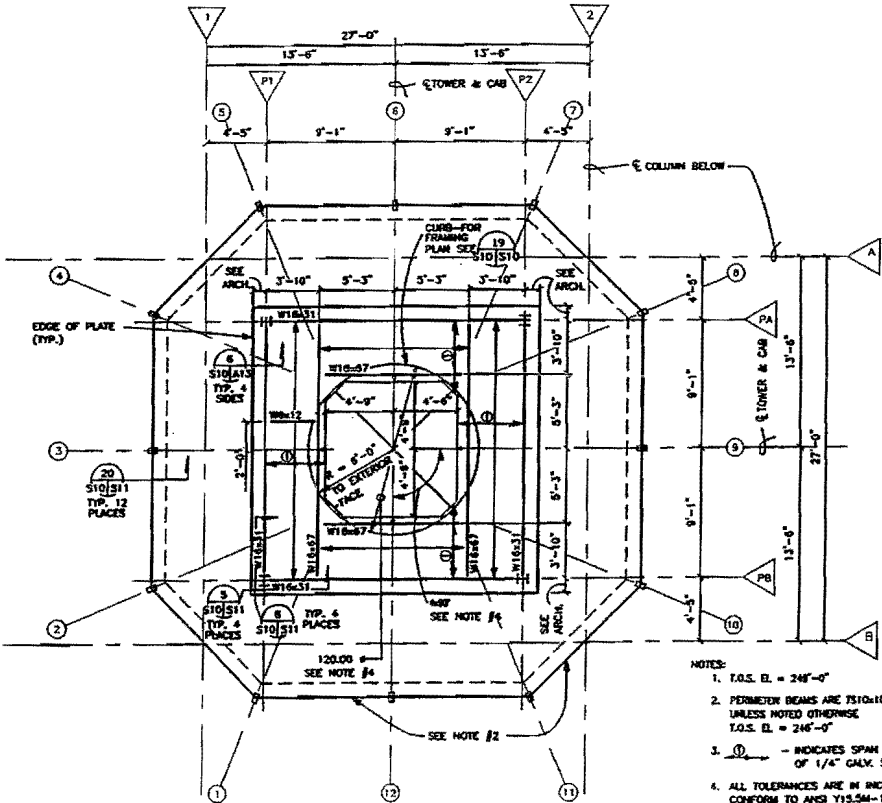

PENTHOUSE ROOF FRAMING PLAN
SCALE: 1/4" = 1'-0"

- NOTES:
1. T.O.S. EL. = 246'-0"
 2. PERIMETER BEAMS ARE W8x24 UNLESS NOTED OTHERWISE T.O.S. EL. = 246'-0"
 3. (Symbol) - INDICATES SPAN DIRECTION OF 1/4" GALV. STEEL PL.
 4. ALL TOLERANCES ARE IN INCHES AND CONFORM TO ANSI Y13.5M-1982.
 5. SEE SHEET S1 FOR STRUCTURAL GENERAL NOTES.
 6. FOR TYPICAL BEAM CONNECTION DETAIL, SEE (Symbol)

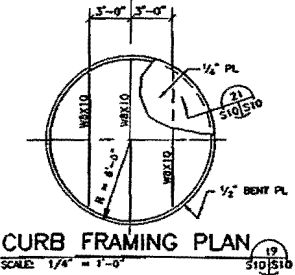

CURB FRAMING PLAN
SCALE: 1/4" = 1'-0"

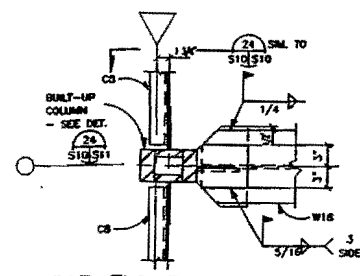

CAB FLOOR MOMENT CONN. @ COLUMN
SCALE: 1 1/2" = 1'-0"

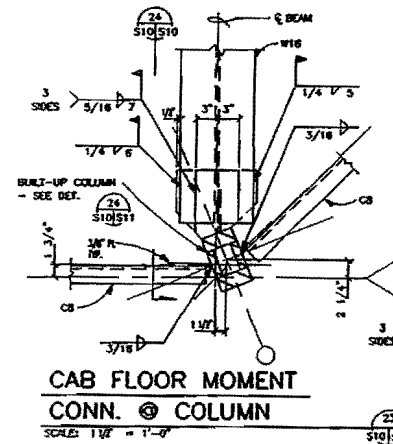

CAB FLOOR MOMENT CONN. @ COLUMN
SCALE: 1 1/2" = 1'-0"

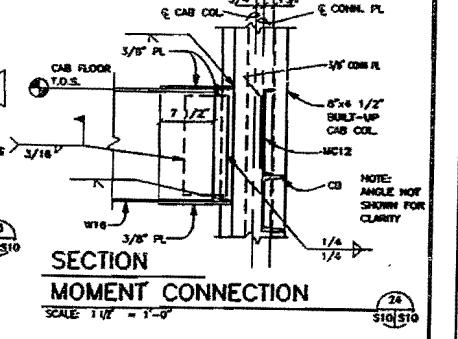

SECTION MOMENT CONNECTION
SCALE: 1 1/2" = 1'-0"

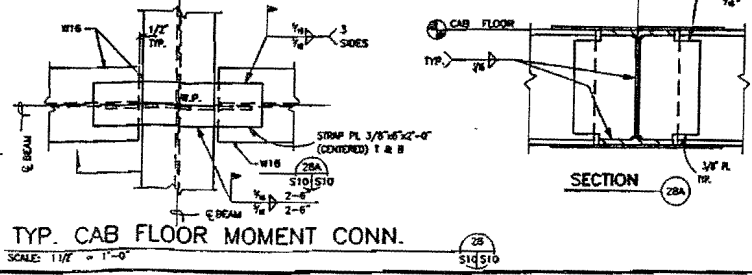

TYP. CAB FLOOR MOMENT CONN.
SCALE: 1 1/2" = 1'-0"

| | | | |
|---|---------------------------|-------|-------------------|
| 1 07/04/97 AS-BUILD (9/1/98) | | 22084 | PL |
| DEPARTMENT OF TRANSPORTATION FEDERAL AVIATION ADMINISTRATION CENTRAL REGION KANSAS CITY, MISSOURI MAJOR ACTIVITY LEVEL AIRPORT TRAFFIC CONTROL TOWER KANSAS CITY INTERNATIONAL AIRPORT KANSAS CITY, MISSOURI | | | |
| DESIGNED BY | APPROVED BY | DATE | BY |
| H & N | ASRAY FACILITIES DIVISION | 04/10 | Chris Stahl |
| H & N | 808 EAST LEXIE STREET | | Chris Stahl |
| | KANSAS CITY, MISSOURI | | Andrew J. Holcomb |
| DATE | NO | REV | BY |
| JULY | 92 | 1 | 3088 |
| DRAWN BY: J. HOLCOMB | | | |
| CHECKED BY: J. HOLCOMB | | | |
| DATE: JUNE 1, 1993 | | | |
| PROJECT: CE-7893-S10-S0-R1.DWG | | | |
| SHEET: 28 OF 28 | | | |

2

7

**Report on Exterior Building Envelope
And
HVAC Conditions**

**Kansas City International Airport and
TRACON Base Building
Airport Traffic Control Tower**

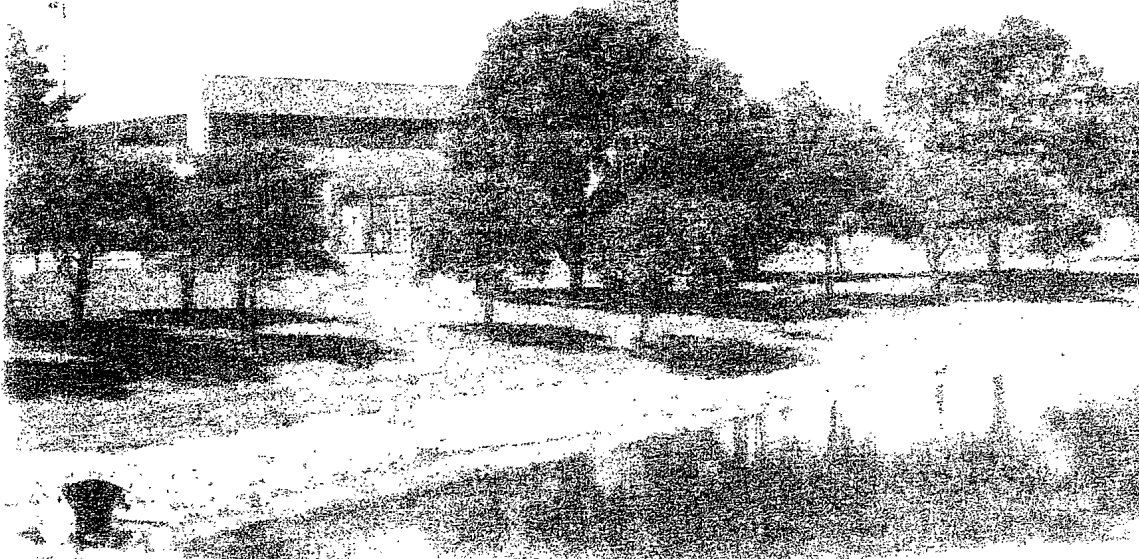

January 22, 2008

DMJM H&N | AECOM

**999 Town & Country Road
Orange, California 92868**

KANSAS CITY INTERNATIONAL AIRPORT
AIRPORT TRAFFIC CONTROL TOWER
AND
TRACON BASE BUILDING
REPORT ON EXTERIOR ENVELOPE AND HVAC CONDITIONS

Table of Contents

| <u>Section</u> | <u>Title</u> |
|------------------------|----------------------------|
| 1 | Purpose |
| 2 | Background |
| 3 | General Construction |
| 4 | Observations and Findings |
| 5 | Conclusions |
| 6 | Recommendations |
| | |
| <u>Appendix</u> | <u>Title</u> |
| A | Photographs |
| B | Catalog Cuts |
| C | Calculations |
| D | Estimate and Priority List |

1.0 PURPOSE

The Airport Traffic Control Tower and TRACON Base Building at Kansas City Airport (MCI) has been experiencing significant water infiltration problems as well as interior moisture issues that have led to mold growth. The subject of mold and its associated environmental concerns has been addressed in other recent reports and is not the subject of this study. DMJMHN visited the facility on July 9-12, 2007 to prepare a study that would assist the Federal Aviation Administration in determining potential causes for water infiltration and high interior humidity. It must be pointed out and noted that it was not raining at the time of the survey and DMJMHN observed no actual water infiltration or condensation on the interior of the control tower and base building. This study and report focuses on observed conditions, discussions with local FAA staff and makes professional architectural and engineering judgments based on those discussions and our observations. The TRACON Base Building and Link are included in this study. The site investigation findings and observation are noted in the sections of this report along with conclusions and recommendations.



MCI ATCT and TRACON Base Building Facility



2.0 BACKGROUND

The MCI-ATCT was constructed during 1994-1995, per the FAA's prototype standard design for a 300-foot Major Activity Level Airport Traffic Control Tower by Leo A. Daily of Omaha, NE. This tower at Kansas City is 15 stories with an overall height of 249'-0" to the top of the ASDE Penthouse. The Cab of the control tower is an 850 sq ft, 8-sided, major activity level Cab. The Tower shaft below the Cab is unoccupied, with the exception of an Electronics Equipment Room and a Mechanical Equipment Room on the Subjunction Level, and a Smoking Room, Office, Breakroom and mechanical Equipment Room at the Junction Level. The tower shaft is served by a 2,500 lbs geared traction elevator and a single, pressurized exit stairway.

The ATCT is connected to the Base Building via a 2-story Link structure.

3.0 GENERAL CONSTRUCTION

3.1 Architectural - Construction And Exterior Envelope

The tower shaft up to the Tenth Floor, at elevation 168'-0" above the Ground Floor, is constructed of a combination of load bearing pre-cast concrete panels and cast-in-place modules with interlocking structural reinforcing steel. Cast-in-place modules are faced with thin shell architectural pre-cast concrete panels with exterior finish to match adjacent structural panels. The basic shape of the structural shaft is 34' square with narrow slanted corners. The structural system above Tenth Floor transitions into steel frame construction that is clad on the exterior with architectural pre-cast concrete panels of concave shape flaring outwards, with the largest floor area at the Junction Level, 208'-0" above the ground floor. The Junction Level is an 8-sided shape derived from a 58' x 58' square with four 15'-6" deep 'shaved off' corners. There are four microwave antenna balconies at this floor. Access to these balconies is through a door in the Smoking Room and another door in the Men's Restroom. There are also four exterior walkways connecting the microwave balconies via hinged metal louver doors. As constructed, the walkways and microwave balconies share the same 4-inch thick concrete floor slab covered with some form of liquid applied waterproof coating. The exterior walkways have a 4" concrete topping over the 4" structural slab. The two south facing microwave balcony floor slabs have large triangular openings with steel grating. These grated openings are areaways for outside air for the HVAC equipment at Sub-junction Level directly below. All structural floor slabs with the exception of solid cast concrete at the Tenth Floor, are constructed of concrete topping over metal deck supported by steel beams. All structural steel framing and underside of metal decks are fireproofed with spray-on fibrous light-density fireproofing material.

The architectural pre-cast concrete panel cladding above Junction Level reverses its direction inward toward the Cab Floor which has a top of concrete elevation of 228'-0". These panels are wedge shaped to form the Cab Walkway enclosure that is 3 feet wide and parallel to the Cab exterior walls.

The Cab is faced with insulated metal panels of embossed finish, secured to the structural steel framing. The cab glazing and exterior fascia panels above the windows are sloped 15-degrees outward from the vertical plane. The glazing system is made up of 1.5" thick clear insulating glass units in an aluminum framing system attached

to and supported by the 4.5" by 8" (approximate) built-up steel Cab columns.

The ASDE Penthouse walls are clad with matching insulated metal panels over steel framing and sub-girts. The penthouse roof is constructed of 1/4" thick steel plate which is insulated on the inside. The method of insulating the ASDE Penthouse shown on the standard prototype drawings (walls on the outside and roof on inside) is not effective in insulating the Penthouse. There are areas around the entire perimeter where exterior temperatures are transmitted through the structural steel to the interior of the penthouse. On top of the Penthouse Roof is a 17" high steel collar on which the ASDE is mounted. The 17" collar is uninsulated as is the entire ASDE rotodome, therefore making it difficult to control the temperature and humidity inside the ASDE Penthouse.

Access to the ASDE Penthouse is through the Cab ceiling by pull down folding ladder and fixed steel ladder above. From the Penthouse there is an access door to the Cab roof which is surrounded by a 42" high parapet wall and steel tube raceway at elevation 246'-0". The steel raceway is for communication wiring and supports antenna mounts, obstruction lights and lightning protection air terminals.

3.2 Architectural - Exterior Finishes and Materials

All exterior facing concrete has an integral colored with a medium exposed aggregate finish. The entire ATCT shaft has been sealed/coated with an acrylic based Canyon Tone Stain. All joints between the structural pre-cast panels and the cast-in-place concrete below the Tenth Floor are solid grouted and sealed with silicone sealant. All joints between architectural pre-cast panels that are above the Tenth Floor Level are double sealed with silicone sealant over foam tube backer rods on the exterior and caulked on the interior.

Exterior walkways at Junction Level and Cab Walkway consist of a waterproofed membrane and concrete topping over the structural concrete slabs. These walkways as well as the microwave balconies have been treated with a liquid applied waterproofing membrane as described in section 3.1 above..

The microwave balconies at Junction Level are screened with large, tensioned fabrics that are UV and weather resistant designed to minimize microwave transmission loss.

Insulated metal panel cladding over the Cab and ASDE Penthouse is described in the Exterior Envelope section above.

3.3 Mechanical Systems Description

The outdoor design condition for this location is as follows:

- Summer design temperature is 96°F DB/ 74°F WB
- Winter design temperature is 6°F.

The tower is supplied with chilled and heating hot water from the base building. The main features of the existing HVAC system are:

- The Ground Floor has an elevator machine room, which is cooled by a ceiling mounted fan-coil unit. Building chilled water is used to cool the room. Elevator Lobby is served by a ceiling mounted fan coil unit with chilled and hot water pipes. The stair vestibule is heated by the ceiling mounted hot water unit heater.
- The Second Floor has finished space used as an office. The entire office area is air-conditioned by ceiling mounted fan-coil unit, using building chilled and hot water systems. The second floor also has unconditioned space in the electrical room (2TS4).
- The Third Floor Fire Pump Room (3TS5) is provided with outside air for ventilation during the summer and warmed with hot water heating coil (HWC-18) during the winter.
- The Fourth through Tenth Floors are unconditioned spaces. These floors are similar to that of the Third Floor.
- The Eleventh Floor is also similar to that of Third Floor, except rooms 11TS5 and 11TS5A are served by fan coil units.
- The Sub-junction, Junction and Cab levels are air-conditioned spaces, except for the mechanical rooms, which are heated by unit heaters.
- The stair shaft is an unheated space, stair vestibules are heated. The stair vestibule and stair itself are pressurized using pressurization exhaust fans and relief dampers. This pressurization system only works in the event of a fire/smoke condition.

4.0 OBSERVATIONS AND FINDINGS

4.1 General Exterior Envelope

The urethane sealant between architectural pre-cast panels of the tower and base building has been replaced. (See photos 4.1-1). This prevents rain water or melting snow to enter wall cavities and get inside the building structure. However, as the photos indicate, the new sealant had some lack of installation quality and appears to be already pulling away from the sides of the joints in some locations, thus creating voids in the sealed surface and potentially allows moisture intrusion into the building. Pre-cast panel interior caulking appears to be in good condition with no visible signs of excessive deterioration. This situation, however, make it's more difficult to trace water leaks, which are channeled to the inside of the structure between the two sets of seals.

The entire exterior surface of precast concrete on both the ATCT and Base Building has been coated with an opaque dampproofing coating. During a walk around the exterior of the Ground Floor, DMJMH&N observed several cracks on the surface of precast concrete panels at the base building (See photo 4.1-2).

The precast concrete panel exterior finish of both buildings is inherently susceptible to transmittance of water vapor if the exterior sealer has deteriorated beyond its useful lifetime. This requires professional advice from the manufacturer and could not be definitively addressed by DMJMH&N. The integrity of the exterior dampproof coating should be checked.

Additionally, there is concern at the vertical joints in the precast panels above the 10th floor. If water, either from the outside or inside, gets behind the sealant, it is trapped and can build up as a column of water. Installation of weeps at the bottom of the vertical sealant joints would allow trapped water to wick to the outside at the 10th floor, thus reducing potential for built-up water to run onto the floor at this level. A similar condition potentially exists at the grouted joints in the structural concrete below the 10th floor. These grouted joints have been covered with sealant in an effort to eliminate water infiltration. Build-up of water behind the sealant could be a problem similar to that described above. Installation of weeps at the bottom of the vertical sealant joints at the ground floor would allow trapped water to wick to the outside.

There are some metal louvers installed through the insulated panel wall that needed to be sealed. Unsealed gaps around louver perimeters are also a potential source of moisture and rain water intrusion

It is noted that the Cab walkway door has a gap on the latch side that allows water entry. In addition, the sill flashing tends to slope towards the threshold which also allows water infiltration (See photos 4.2.2-2 and 4.2.2-3).

Penetrations of the walkway present additional leak sources to the integrity of the waterproofing membrane (see photo 4.2.2-5). While not observed, it was noted by the FAA that water leaks into the Cable Access Level between one or more of the Cab Walkway drains and the floor slab, indicating a potential leak at the drain, or a leak somewhere else with the water traveling under the sandwiched waterproofing membrane then leaking at the drain.

A vent pipe exits at the cab walkway and moisture in the air coming from the vent pipe condenses and drips on to the walkway (See photo 4.2.2-6).

There are noticeable water stains on the wall and sloped ceiling of the cab stairs under the Cab sink area, apparently from previous leaks (See photo 4.2.2-7).

4.2.3 Cable Access Level

The perimeter wall of the Cable Access Room is comprised of metal studs and batt insulation faced with the kraft paper (vapor barrier) on the warm side of the wall. The outside of the wall is finished with water resistant gypsum wallboard. In several areas the vapor barrier has been compromised which will allow moisture to migrate to the cold side of the wall providing for the possibility of condensation. (See photo 4.2.3-1)

There are some metal louvers installed through the insulated panel wall that needed to be sealed. Unsealed gaps around louver perimeters and along the bottom of the insulated metal panels are also a potential source of moisture and rain water intrusion as evidenced by water stains on the steel behind the panels and louvers (see photo 4.2.3-2). It has also been observed by the FAA during the winter months that



observed. The gypsum board shaftliner panels had water streaks or stains at many locations (see photo 4.2.4-1). There were whitish stains on metal studs and tracks which could indicate possible water stains as a result of presence of moisture inside of the shaft. This could be caused by either condensation or a direct run of water over metal surface, under some extreme conditions. Since this shaft is located within the center of the tower and directly under the Cab, it doesn't seem to be possible that outside water would ever migrate directly to the top of the elevator shaft. Therefore, the most probable sources of moisture presence could be water leaking into the shaft at unoccupied floors below from melting frost or, possibly, from back draft from the elevator smoke relief which is ducted to the outside louver at Cab Walkway above.

4.2.5 Junction Level

It should be noted that the temperature and humidity in the corridor from the stairway to the lockers was unusually high at the time of this site visit.

DMJMHN started the inspection in room J10. The floor drain in this room has several drain lines emptying into it. The funnel for the floor drain was missing or never installed allowing water to splash and run across the floor and under the floor tiles, especially from the blowdown of the humidifier. As a result, the drain is very corroded and there are stains on the wall and floor. The water also finds its way down to the Sub-Junction level below as evidenced by the visual corrosion on pipes above the ceiling (see photos 4.2.5-1, 4.2.5-2).

J12 is a Mechanical Room with a partially clogged floor drain that requires cleaning to be able to support the four condensation lines emptying into it. The installed drain is not appropriate for accepting indirect waste lines. Also, there are leaking pipes in need of repair (see photo 4.2.5-3, 4.2.5-4). The leaks may also be caused by breaches in the vapor barrier jacket on the chilled water piping.

Door J8A head is missing the weather stripping which allows air and water leaks as noted by the staining on the door.

We accessed the Microwave balconies from both the Men's Restroom access door and the access door in the Smoking Room. This allowed for inspection of all four microwave

balconies and exterior walkways. The surfaces of the concrete slab at the exterior walkways and the balconies were treated with some form of a waterproofing coating that appeared to be in good condition; however, it has been observed by others that there are leaks in the sub-junction level below, especially in the area of Walkway #1 on the north side of the tower. Therefore, it must be assumed that there is a problem with the waterproofing membrane sandwiched between the structural concrete slab and the concrete topping on the walkways.

Along the exterior walkways are glazed guardrails mounted to the 3"x3" sq. steel tube posts which are spaced at 48-inch on center. At the top of these posts, there are holes approximately 5/8" in diameter on opposite sides of each post to act as vent holes. These posts are welded directly to the top flange of the I-beam below, which is supporting edge of walkway slab. The wind driven rain can cause water intrusion inside the tube and then to the inside of structure below (See Photos 4.2.5-5). However, it has been reported that these holes were plugged and sealed right after the site visit, thus not contributing to water intrusion anymore.

It was noted that in several places along the Junction Level Walkway that the gaskets for the storefront framing have deteriorated, creating gaps along the bottom of the insulating glass unites (See photo 4.2.5-6).

Janitor Room, #J11: Water damage to the floor adjacent to the service sink (see photo 4.2.5-7). It appears that water has leaked through the slab to areas below such as the Subjunction Level corridor ceiling and one of the light fixture lenses had water stains. Water may be getting under the service sink and leaking through at the penetration in the slab for the drain line or possibly getting under the wall and around the edge of the slab at the elevator opening or at a pipe penetration in the adjacent chase.

4.2.6 Sub-Junction Level

The Mechanical Room at the Sub-Junction Level is located directly below the Junction Level South Walkway and Mechanical Room J12. Photos clearly indicate rusted floor drain and leaking pipe causing leaking and staining at the 11th Level (See photos 4.2.6-1, 4.2.6-2, and 4.2.6-3).

room SJ1 will condense (and freeze) on the cold interior surface of the pre-cast panels. This condensation (or melting ice) will drain down the inside of the precast panels all the way to the 10th Floor. Inspection of this concealed space under the Junction Level walkways by others from interior of the Sub-Junction Level has revealed some water stains and moisture intrusion.

DMJMHN did not observe this but, it was brought to our attention that door SJ8 to the exterior air shaft apparently has a poor seal that has caused condensation and damage to the adjacent gypsum board wall.

4.2.7 Eleventh Floor

DMJMH&N accessed this level thru the stairway coming from Sub-Junction Level above. Stairwell walls appeared to be in good condition, no staining was observed at or above of the floor landing. The entire stairwell is enclosed with 2-hr fire rated walls and designed to be pressurized. Access to stair landings is through the 4-foot wide pressurized vestibules that are typical at all levels. Water stains and discoloration were found on the concrete floor and gypsum board wall of the stair vestibule. Apparently a fire sprinkler line leak had been repaired and it was assumed to be the cause of the stains. The stair vestibules at all levels are very warm apparently due to the continuous recirculation of hot water through the unit heaters.

At this level all interior spaces are surrounded by the shaft wall similar to the Sub-Junction Level above, creating a narrow void space between the exterior pre-cast concrete and the shaft wall. DMJMH&N accessed this void space through an access panel at the south wall of Corridor 11TS1. There was construction debris throughout this space that revealed evidence of moisture intrusion which has been cleaned out. The moisture was probably from the surface condensation or joints of the pre-cast concrete walls (see photo 4.2.7-1). This space was observed to have heavy condensation and frosting on the inside of the pre-cast walls during the winter months. Water stains have streaked the walls. The FAA noted that "the fire safing has heavy concentrations of mold and must be removed and replaced. The fire safing was repeatedly wetted and dried after exposure to leaks from building joints, leaks from the floor drain above and from condensation and melting frost on the interior face of

the precast panels” Investigating and mitigating mold issues is outside the scope of this study and report.

Due to this being a very narrow space with structural bracing at each end of the wall it was impractical to inspect the entire perimeter of the inside of the pre-cast panels. The west wall of room 11TS5 was known to have leaks. This could be attributed to the leaking floor sink above in the Sub-Junction Level under the raised flooring. The pipe insulation at the east wall fan coil unit is water stained and should be checked for leaks.

The Mechanical and Electrical rooms at the east side east of the elevator hoistway were inspected and both rooms were dry and very warm inside.

Room 11TS5 has water stains on the concrete slab along the bottom of the gypsum wallboard in the proximity of the column enclosure and visible rust on the diagonal bracings coming from under the sprayed-on fireproofing. There are two precast concrete wall connections which penetrate the shaft wall into the room and also have signs of corrosion probably the result of condensation (See photos 4.2.7-2).

Frost and ice were seen on the walls and floors in the area outside the shaft wall on the 11th floor (see photo 4.2.7.3) on January 18, 2007.

4.2.8 Tenth Floor

The Tenth Floor interior wall configuration is almost identical to the Eleventh Floor above; with all interior spaces surrounded by a shaft wall, creating the narrow void space between the shaft wall and the exterior pre-cast wall. Moisture condenses on the inside of the pre-cast panels similar to the 11th floor above.

The stair vestibule 10TS6 (typical for all levels from 2nd to 11th) is very warm due to the hot water recirculation piping for the unit heater.

Typical for all mechanical chases at levels from 3rd to 11th are very warm, likely due to the uninsulated hot water piping in the plumbing chase.

The top of the floor slab at this level also signifies the top of the straight and vertical tower shaft below. At this level the transition is made to the concave shaped architectural pre-

cast panel exterior enclosure. Therefore, a conclusion can be drawn that there is a first horizontal joint with sealant and caulking along bottom of these panels. Since interior walls are completely closed, DMJMH&N could not make visual observation of these joints; however, there were several water stains on top of concrete slab in the proximity of the perimeter walls. This is not a conclusive statement that water may be leaking from the bottom of exterior pre-cast panels, just a possibility, as water and moisture could also permeate down from the levels above. One of the potential problems is with water getting behind the sealant at the vertical joints which is described in more detail in paragraph 4.1.

Following inspection of the stairway at this floor, DMJMH&N entered Room 10TS5 which is an unoccupied space in the northwest portion of the Tower shaft. There was a noticeable difference in the air temperature between this room and the Elevator Vestibule. Unoccupied Room 10TS5 was cool, since it is not conditioned, while the adjacent elevator vestibule was warm. Room 10TS5 has full height interior walls covered with painted gypsum wallboard and exposed structural framing with metal deck above covered with sprayed-on fireproofing.

In Room 10TS5 there were water stains on the concrete slab along the bottom of the gypsum wallboard in the proximity of the column enclosure (See photo 4.2.8-1). Additionally, Room 10TS5 has water damaged to the gypsum board at several locations along the base.

Room 10TS5, observations by others noted that after warmer outside temperatures on January 19, 2007, frost on the precast panels began to melt and water began to accumulate on the floor slab at the north wall (see photo 4.2.8-2). Observations have also shown entire surfaces of the interior side of precast panels at this level and above (as well as several levels below) covered in frost or condensation to the point where water runs off the panels and causes building materials to get wet. Any leaks from above and the majority of water from frost melting accumulate on the 10th floor because the slab caps off the straight section of the tower levels.

4.2.9 Ninth Floor

The Ninth Floor is the first Tower shaft floor (counting from the top down) that has uninsulated and unfinished exterior

concrete walls. This is a double height floor with the intermediate beams at elevation approx. 12 feet above floor and steel grating in the upper portion of the Electrical Chase.

The west end of room 9TS1 has very visible water stains on the perimeter of the corridor ceiling. The west wall is the exposed exterior pre-cast concrete wall. The floor tile at the west end of the corridor has water stains and white residue at the joints. (See photos 4.2.9-1 and 4.2.9-2)

A visual inspection was made by others through the ceiling access panel in the 9TS6 stair vestibule that showed water stains on the north, east, and west walls above the ceiling. The worst condition was in the northeast corner.

In Room 9TS4, others had observed melting frost and condensation on the north and east walls January 19, 2007 (see photo 4.2.9-3).

4.2.10 Eighth Floor

A visible inspection was made through the access panel in the 8TS1 corridor ceiling. There was visible water stained fireproofing on the underside of the 9th floor metal deck.

There was some indication of moisture intrusion observed on the south wall above the fireproofed beam in the same space above the ceiling. In the stair vestibule 8TS6, through the access panel a large area of discoloration (moisture intrusion) was observed on the west wall gypsum board.

Electrical Chase, Room 8TS4 was generally warm but dry. There was some evidence of deposit of efflorescence along the grouted joints and water stains. This is typical in all of the Electrical rooms floors Nine through Three (See Photo 4.2.10-1).

It was noted by others that condensation and frosting were seen on the west wall of room 8TS5, on January 18, 2007 (see photo 4.2.10-2).

4.2.11 Seventh Floor

This level has been constructed almost identical to Eight Shaft Level above, with fireproofing applied to its underside.

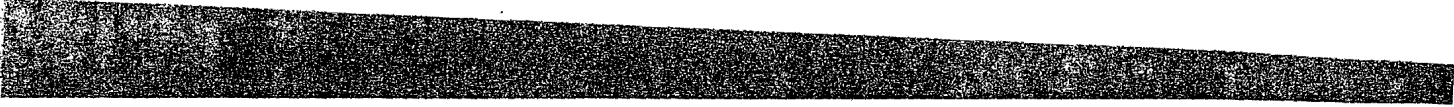

The interior air was hot and humid, and there were stains on fireproofed beams and floor deck above, possibly caused by moisture coming from above.

4.2.12 Sixth Floor

Floor layout and wall construction the same as the Seventh Floor. This floor was hot and similar moisture related problems.

In room 6TS3, the end caps of the hot water pipes are dripping (see photo 4.2.12-1).

4.2.13 Fifth Floor

The Fifth Floor layout and wall construction is the same as the Sixth Floor above.

There were visible water stains on the vertical concrete walls (See photo 4.2.13-1).

4.2.14 Fourth Floor

This floor is dedicated to the stair pressurization fan, outside air intake louver and related ductwork.

Wind driven rain spills over the intake louver and migrates down to (2) 20"x8" outside supply air ducts (see photo 4.2.14-1, 4.2.14-2). Water stains appear on the 2nd floor level and ground floor level (see photo 4.2.14-3).

4.2.15 Third Floor

This floor has the fire pump in 3TS5, yet is very similar in layout to the Fourth Floor above.

Room 3TS5, has a badly corroded floor drain too small for the use. Three pipes drain to floor drain and probably cause overflow of water which leaks through the slab to ceiling of floors below (see photo 4.2.15-1).

Information gathered by the FAA inspection indicated that the water damage was caused by the discharge of water in room 3TS5 during maintenance and testing of the fire pumps. This room has multiple cracks in the concrete slab which have allowed water to leak to the floor below or into the elevator shaft.

4.2.16 Second Floor

The Second Floor of the ATCT is connected to the Base Building Second Floor thru the Link structure at its east facing wall. This level had a functioning office space in Room 2TS5. This same space is typically unoccupied at upper floors. There were several moisture related problems on this level. In the office there were several large water stains on the acoustical ceiling tiles on the west side of the elevator shaft and water streaks and stains on the elevator shaft walls (see photo 4.2.16-1). Information gathered by an FAA inspection indicated water damage to the ceiling tiles and interior walls were caused by discharge of water in room 3TS5 during maintenance and testing of fire pumps.

Also, stains can be seen on the west wall in Room 2TS5 from water infiltration at the 4th Floor outside air intake louver.

4.2.17 Ground Level

At this level there is an elevator lobby directly accessible from the Ground Floor level of the Link. The tower stairway provides direct discharge to the outside and is not accessible from the elevator lobby.

We accessed the Ground Floor Electrical Room, GTS3, from the elevator lobby. The north and east walls of this room were uninsulated with exposed concrete and the room was unpainted with a bare concrete floor.

In Room G4, chilled water pipes at AHU-16 are dripping (See photo 4.2.17-1, 4.2.17-2).

Apparent water damage at west wall is from the fourth floor outside air intake louver leaks that have migrated to the first floor (see photo 4.2.17-3).

4.2.18 Excessive Interior Humidity – General Discussion

Moisture and humidity in the ATCT are the result of several factors:

- Moisture infiltration from the exterior environment
 - Humidity through walls
 - Leaks in exterior envelope
- Water leaks within the building
 - Pipe leaks

- Poorly functioning drains
- Building occupants
 - Moisture from breathing
 - Cooking
- Moisture added via humidifiers

Since the tower has been sealed on the outside (both the joints and the concrete surface) we believe that actual water infiltration is not a likely cause for the moisture on floors 11 and below. Also, while there have been pipe leaks of various types that have caused problems on the upper floors, again, we do not believe this to be a significant contributing factor to the moisture, condensation and frost (in the winter) on floors 11 and below. Finally, with the limited number of staff in the tower, people are not seen as a major source of humidity. This leaves us with water vapor (from the exterior environment and internally from humidifiers) in the air as the prime contributing factor to the moisture and condensation problems on floors 11 and below

There are humidifiers on the Junction and Sub-junction levels and the water vapor will tend to equalize itself between different areas just as air pressure will do. This means that the moisture in the Junction and Subjunction levels will tend to migrate down (or out of) the shaft, gradually dissipating to the floors below. This conclusion is consistent with the conditions in the tower because the condensation (and icing) gradually decreases below the 11th floor (Sub-junction Level) and below the 7th floor is almost non-existent. In the warmer months, when the outside air contains a lot of moisture, this compounds the problem of the humidifiers. The result of the excessive moisture in the tower is mold growth when the temperatures are warm and condensation when the temperatures are cold.

During the warm humid months, when the air is capable of holding large amounts of moisture, dehumidification is recommended. However, during colder months, when the air holds less moisture, heat and ventilation are recommended. As an example, if it were 32-degrees outside with a relative humidity of 80%, when that same air is warmed to 70-degrees, the relative humidity is only 17%. The exchange of high humidity air with low humidity air will lower overall humidity in the tower shaft. However, the practicality of installing supply and return air ducts throughout the tower shaft is

questionable. As a result, heating and/or dehumidification will be the recommend year round solution to the problems experienced on floors 3 through 11.

4.3 Link and Base Building

4.3.1 Exterior Conditions

Inspection of the exterior elevations of the Link and Base Building revealed numerous water stains at and around building aluminum storefront framing. Typically stains and visible streaks originated at the glazing head at interface with pre-cast concrete panels. At the time of this inspection all glazing panes along the exterior perimeter had received a continuous bead of sealant, applied over existing gasketing. According to the user statements, wet sealing of windows stopped the majority of water leaks to the interior. There are still visible stains on the surface of the aluminum framing caused by water running down the pre-cast panels and toward the window, along slanted portions of the pre-cast concrete panels. There is a kerf at the bottom of the pre-cast panels, intended to prevent the flow of water toward the windows. However, the main cause for concern are the corners of the mitered and sloped pre-cast panels below second floor overhang. This panel configuration channels rainwater directly toward the aluminum corner posts of the first floor window frames (see photos 4.3.1-1, 4.3.1-2 and 4.3.1-3). The second floor window framing appeared to be in much better condition.

There is also concern with the direct attachment of clamping rings for support of down conductor conduits. If they are not properly sealed and/or gasketed, this may be a source of water intrusion to the inside of the storefront framing, thus to the interior of the building envelope (see photo 4.3.1-4). Similar attachment of clamps to the face of the pre-cast, if left unsealed, can cause water intrusion into the concrete, and during the winter season may eventually cause deterioration due to a freeze-thaw cycle (see photo 4.3.1-5). We also noticed numerous unsealed penetrations through the pre-cast panels, such as unused bolts (see photo 4.3.1-6), telephone boxes (see photo 4.3.1-7), and electrical outlets (see photo 4.3.1-8).

Other areas of concern on the exterior are deteriorating weatherstripping on the hollow metal doors along the north



elevation and equipment yard, some double doors that lacked astragals at the meeting stiles (see photo 4.3.1-9), and gathering debris at the bottom of the first floor pre-cast panels (see photo 4.3.1-10) which may prevent water flow away from the building and its eventual intrusion into the building interior. At several exterior doors along the north elevation, improper threshold types and installation as well as deteriorated door weatherstripping have been the cause of major intrusion of rain water and melting snow into the building interior (see photos 4.3.1-11 and 4.3.1-12).

Inspection of the Link exterior curtain wall revealed missing and/or deteriorated gasketing at glazing corners, which may cause water intrusion into the interior and eventual deterioration of insulating glass units (see photos 4.3.1-13 and 4.3.1-14). Open and unsealed joints between snap-on covers and vertical mullions were observed, through which rain-driven water and melting snow will find its way into the interior (see photos 4.3.1-15 and 4.3.1-16). There is also evidence of water intrusion through the storefront entrance doors at Link (see photos 4.3.1-17 and 4.3.1-18). A possible cause for this is the construction of the entrance canopies where there is an open gap between the Link's curtain wall and the back of the canopy structure (see photo 4.3.1-19).

4.3.2 Roof

The DMJMHN team accessed the low roof over the mechanical wing from the exterior steel ladder. Surface inspection of this roof indicated that there were no major problems, with some minor exceptions. The sealant between pre-cast panels along the east wall of the high bay is punctured in several places (see photos 4.3.2-1 and 4.3.2-2). This condition may allow water intrusion to the inside of the high bay wall structure and subsequently damage the interior wall finishes and ceilings. It was not possible to assess the conditions of the roof membrane under the concrete pavers. However, an area of concern is the visible occurrence of moss and/or some sort of organic matter along roof parapets and corners (see photo 4.3.2-3).

Following inspection of the low roof, the DMJMHN team accessed the high roof via the stair ladder and roof access hatch. This roof has many problems where there is potential for deterioration of the single-ply EPDM roofing membrane that is covered with concrete pavers. In many areas the roof



pavers were bent, broken and crumbling with some sort of visible, moss-like, organic growth under the pavers. This situation prevailed along the roof parapets and corners (see photos 4.3.2-4 and 4.3.2-5). These conditions were also apparent at and around almost every roof drain (see photos 4.3.2-6 and 4.3.2-7). Removal of some of the roof pavers revealed a deteriorated protection layer, with debris and organic matter visible under the pavers (see photo 4.3.2-8). This situation raises questions of the integrity of the single-ply roofing membrane, which is significant when combined with documented leaks at the second floor ceiling coming from the roof above. Removal of the pavers and inspection of the entire roof membrane was beyond the scope of this project. However, there is enough evidence to suggest roofing membrane failure in some areas.

Some other areas of concern included conditions along parapet walls that are covered with EPDM flashing membrane. There are numerous points where plastic clips were installed along the parapet wall on the side that is facing the roof. Most of the clips are no longer used and are crumbling (see photo 4.3.2-9) or pulled out together with mastic and the parapet flashing, thus creating points of water and moisture intrusion under the roofing membrane below (see photo 4.3.2-10). At many pipe-thru roof penetrations, the rubber flashing is inadequate because it was installed too short. Typical EPDM boot flashing should extend a minimum of 8 inches above the top of the adjacent roofing surface before clamp and sealant can be installed (see photos 4.3.2-11 and 4.3.2-12).

At the southwest portion of the high roof there is a skylight with a group of nine plastic domes (see photo 4.3.2-13). There is some evidence of sealant failure along the skylight perimeter flashing (see photo 4.3.2-14), as well as water stains at the low point of the skylight domes. This may cause water leaks to the building interior if seals and/or gasketing failure occurs at intersections of skylight frame and top pressure plates (see photo 4.3.2-15). The curb around the skylight has a relatively low profile, and its height above the roof membrane is further reduced by the depth of the concrete pavers. In the winter season the snow may build up along the sides of the curb and over the low points of the skylight domes. Along the top of the curb flashing there are drip holes which may allow

uncontrolled water intrusion while snow build-up starts to thaw (see photo 4.3.2-16).

Inspection of the Link roof did not reveal any major problems, yet there is a concern of possible improper slope on the portion of the Link roof adjacent to the tower structure. Photo 4.3.2-17 appears to show a slight roof line depression along the curb at the expansion joint between the Link and the ATCT. There should be a uniformly continuous high point across the entire width of the Link, forming a cricket which should slope toward the roof drain. This may cause ponding of water under the pavers and potential failure of the roofing membrane.

Another typical problem which occurs at all other roof areas is deterioration and build-up of organic matter around roof drains (see photo 4.3.2-18).

4.3.3 Second Floor

Following the inspection of the roof, the team investigated the interior of the second floor. Since there was evidence of water stains on the suspended ceiling panels at the first floor corridor along grid line 3, the second floor inspection began with the Radar, TRACON and Communication Rooms, where there is an access floor panel system. There are two floor sinks under the raised floor in proximity to CRAC units in the Radar Room, #204. After lifting of floor panels we discovered major water stains on the concrete slab due to leaking pipes and clogged drains. (see photos 4.3.3-1, 4.3.3-2 and 4.3.3-3). Also in Radar Room #204 there were water stains on the suspended ceiling panels in proximity to grid line D & 5.

Following inspection of the Radar and TRACON Rooms, the DMJMHN team entered Room #221 AF Communication Workshop where there was extensive water staining on the suspended acoustical ceiling panels (see photo 4.3.3-4). When the ceiling panels were removed for further inspection of the space above there was no direct evidence of water dripping on the acoustical ceiling; however, there was noticeable rusting along the roof metal deck perforated flutes (see photos 4.3.3-5 and 4.3.3-6). Since there was no other source of water leakage in the immediate proximity to the stained ceiling panels, it is reasonable to suspect that rust on the metal deck could be a result of the roofing failure above. It should be noted that perforations along the metal deck

flutes are meant to facilitate curing of the insulating concrete fill above the deck. While most of the perforations were whitish and relatively clean, the visible rust on some flutes could only be caused by the water migrating from above. There were similar water stains over the 24 x 24 acoustical ceiling panels along Corridor #225 between the Women's Restroom #220 and above the entrance to the Locker Room #218 (see photos 4.3.3-7 and 4.3.3-8).

There were also water stains over the gypsum board ceiling in the Breakroom #217 and around recessed "can" light fixtures (see photos 4.3.3-9 and 4.3.3-10). According to the FAA these stains were caused by the leaking skylight above, which was subsequently repaired and the leaks eliminated.

During inspection of all perimeter offices, it was noted that in almost every room with exterior windows the gypsum wallboard at the bottom of the window jambs was soft and deteriorated, and plastic laminate window stools and wallcoverings were delaminating due to moisture (see photos 4.3.3-11 through 4.3.3-16). All window framing was displaying water stains due to rain water intrusion, which were common prior to wet sealing of glazing from outside.

4.3.4 First Floor

First floor inspection revealed numerous and multiple water stains on gypsum walls, over acoustical ceiling panels, and on floors. The DMJMHN team commenced inspection of this floor with AMT Room #126 where there is a cable tray penetration to the second floor above. The north wall of Room #126 displayed water stains coming from the cable tray opening above (see photo 4.3.4-1). Subsequent inspection of the second floor revealed a path of water from the nearby floor sink, which found its way to the floor opening for the cable tray (see photos 4.3.4-2, 4.3.4-3 and 4.3.4-4).

Inspection of the space above the ceiling in Corridor #128 in the proximity of Room #126 revealed corroded and leaking pipe connections (see photo 4.3.4-5).

Inspection of the rooms dedicated to building services revealed numerous leaking and corroded pipes, valves and connectors, water stains on the floor, corroded floor sinks, etc. (see photos 4.3.4-6 through 4.3.4-9). Most of the leaks were occurring within Mechanical Room #101.



directly below the Tracon and Communication rooms on the second floor. There are multiple duct and pipe penetrations through the recessed floor slab above. When leaking water and other liquid substances evaporate, moisture will permeate up the floor and through unsealed openings, thus contributing to the overall level of humidity within the building.

After inspection of building services areas, the team visited perimeter offices beginning with the A.F. Manager Room #110. There were numerous water stains on the carpet at and around the column enclosure at the southeast corner of the room (see photo 4.3.4-10). In addition there were large stains and oxidation on the vertical window mullions running down from the window head above (see photos 4.3.4-11 and 4.3.4-12). Water infiltration into the gypsum board at exterior walls caused delamination of plastic laminate and fabric wallcovering at window sills (see photo 4.3.4-13). According to the FAA, water leaks through the window framing stopped after the wet sealing of the exterior glazing. However, there is still evidence of moisture at the bottom of corner columns. This may be due to the configuration of the mitered corner pre-cast concrete panels at slanted soffits above window heads. It is very apparent that this configuration channels rain water from above into the upper corner of the window framing below.

Further inspection of the perimeter office areas revealed similar problems with water stains on the window framing and delamination of wall coverings and plastic laminate at almost all intersections of window jamb and wood stools at window sills (see photos 4.3.4-14 and 4.3.4-15).

Janitor Room, #134: Water damage was noted on the tile floor in front of the service sink as well as water stains on the gypsum board walls adjacent to the ceramic tile wainscot. The service sink has cracks on the front and an adjacent electrical receptacle was damaged and water stained (see photo 4.3.4-16).

5.0 CONCLUSIONS

The timing of the site visit did not allow for first hand verification of water and moisture intrusion. However, the residual signs and damage of materials still present provided evidence of significant problems which have occurred. A combination of existing construction and Kansas City weather conditions provide opportunities for water and moisture intrusion to the interior of the tower shaft and base building. A major contributor to excessive moisture problem would be through the exterior envelope at roof areas and sealed joints between architectural pre-cast panels, and to a lesser degree through grouted joints between pre-cast and cast-in-place concrete walls. The tower was recently resealed and generally joints appear to be in very good condition. The tower humidity levels during the winter months are a result of internal moisture sources. Even moderate humidity inside buildings can produce wetting by condensation on exterior walls and on the building structure because of moist air contacting surfaces below the dew point. Internal sources of moisture in the tower are

- Personnel
- Building humidification systems
- Poorly functioning floor drains
- Water from snow melt leaking into the buildings

The floor drains in Junction Level room J10 and Subjunction Level SJ1 do a poor job of draining the pipes directed at them. These drains flooded multiple times and caused water infiltration at several floors below causing deterioration of building materials. In general, we also noticed leaking in piping systems to some degree in both tower and base building. Many of the plumbing lines to the floor sinks were not located properly and end up splashing water to the surrounding areas or they miss the sink entirely.

The most dramatic effect of moisture in the tower is during the winter when condensation creates a build-up of frost on the concrete panels at the inside spaces. The worst problem at the base building is evidenced by the water leaks at the window frames. The impact of this moisture intrusion and damage is illustrated in the base building from moisture condensation behind the impermeable wallcoverings like the vinyl and rubber base. The occurrence of condensation places limits on the humidity that can be carried in the buildings in winter. Other consequences of water and moisture intrusion are mold and deterioration of materials.

Likely contributing factors were as follows:

- Poor maintenance of exterior envelope. This issue has been addressed by the FAA resealing the exterior joints of the pre-cast panel system at the Tower and Base building.
- Roofing and flashing deterioration (especially at the Base Building).
- Inappropriate insulation
- Lack of insulation
- Insufficient mechanical circulation of warm air in unconditioned spaces.
- Mechanical humidification.
- Fan induced pressure differences. Significant pressure imbalances between adjacent rooms forces warm moist air into unconditioned spaces where it condensed.
- Improperly sealed wall penetrations, which acted as conduits for air transported moisture movement into cold cavity spaces.
- Plumbing leaks
- The rate at which moisture is supplied to the air within the building by conditions such as plumbing leaks, overflow at floor drains, and roof leaks, etc.

In addition to maintenance related items, there are also problems related directly to the design prototype used as a basis for construction of this tower and base building.

- Configuration of architectural pre-cast panels at the top of the tower makes it difficult to identify failed joints and then to repair any failed sealant at joints.
- Fascia to soffit transition configuration of architectural pre-cast panels at the base building creates a challenging joint to prevent leaks. Lack of a good drip edge directs water from the fascia to this joint or down the soffit surface to the top of the window frame, which lacks a metal drip, then depends on good sealant to prevent water and moisture entering the framing system and wall cavity.
- Raised concrete curbs along walkways are of profile that is too low to stop rainfall water from overflow and finding its way to the interior of structure.

- The balcony handrails juxtaposition to the pre-cast panels does not allow for proper roofing and flashing conditions.
- There are many exterior concrete walkways and microwave balconies which constitute a roof over interior spaces, therefore, potential for leakage to interior is greatly enhanced.
- Lack of waterproof floors in the mechanical rooms
- Installation of drain lines and traps in unconditioned spaces.
- Lack of access to concealed spaces especially those with plumbing lines.
- Size, shape and use of pre-cast panels and joints leads to cracking, and joint failure contributing to moisture infiltration.
- Very cold weather during the period with some intermittent warm days producing freezing and thawing. This action causes cracks and pockets in pre-cast panels. This same weather condition combined with high humidity levels and low surface temperature of pre-cast panels in unconditioned spaces produces condensation on interior tower panels.

Design of the tower shaft was based on the assumption that most floors will be unoccupied; therefore exterior walls at levels up to the Ninth Floor were specified as uninsulated and not provided with mechanical conditioning or ventilation. This approach, while reducing the initial construction cost, did not consider the long term and environmental impact of these decisions.

6.0 RECOMMENDATIONS

This section on recommendations is formatted similar to Section 4, OBSERVATIONS AND FINDINGS AS FOLLOWS:

- General Exterior Envelope
- ATCT
- Base Building

6.1 General Exterior Envelope

6.1.1 Repair Joints Between Pre-cast Concrete Panels

Maintain the recently resealed joints at the Tower and Base Building. Provide continuous examination of joints for drying, cracking and pulling away from the surface of the joints. Install wicks at the bottom of each vertical joint (10th Floor) between pre-cast panels to drain any build-up of water to the outside. Weeps should also be installed at the ground level at the bottom of each vertical sealed joint.

6.1.2 Waterproof Exterior Concrete

The Control Tower and Base Building were originally coated with Canyon Tone Stain by United Coatings. This is a water-based acrylic penetrating pigmented sealer with a 5-year manufacturer's warranty. It is recommended that the FAA contact the manufacturer's representative and have the exterior of the control tower and base building evaluated for its current integrity and to provide recommendations for the possible cleaning of the existing surface with reapplication of another coat of sealer. Our cost section will have these costs included in the event that the manufacturer makes such a recommendation.

6.2 Control Tower

6.2.1 Cab Roof and ASDE Penthouse

Install rigid insulation to the exterior of the bent steel curb to and tapered insulation (R-30) on the roof of the Penthouse and then wrap the insulation over the corner of the roof down to the insulated metal panel walls. Cover new vertical and horizontal insulation with single-ply membrane roofing.

Provide extended shroud at ASDE rotodome and, if possible, provide a seal between the rotodome and the curb with overlapping rubber flaps or a continuous brush strip.

Reseal penetrations in the Penthouse siding and around louvers.

Verify capacity of the electric unit heater (68,300 BTU) and verify that it is working properly. Thermostat should be set at a minimum of 45-degrees F. during the winter.

In Room PH1, verify that the control damper (CD-128) of exhaust fan EF-12 is a low leakage damper with insulated blades. If it is, verify proper operation. If not, it is recommended to replace it with a low leakage damper with insulated blades.

Properly repair all patches in the cab roof single-ply membrane in accordance with the manufacturer's instructions. An option would be to completely replace the single-ply roofing membrane. Provide and install walkway pads as approved by the membrane manufacturer. A roofing consultant should be retained to inspect the integrity of this roofing and flashing.

Install a recirculation fan in the space above the cab ceiling with supply and return air grilles. See Catalog Cut.

Replace damaged or stained ceiling tiles in cab.

6.2.2 Cab Walkway

Remove concrete topping/walking surface and waterproof membrane on the entire cab walkway. Remove and replace walkway area drains with new drains. Clean and prepare concrete surface for new single-ply PVC roofing. Install tapered insulation and single-ply PVC roofing with proper flashing at base of insulated metal panels and louvers around the inside and outside perimeter. Install continuous sheet of walkway surface to protect roofing membrane.

Properly secure unistrut for lightning protection down conductors to the insulated metal panel walls to eliminate bolts in the surface of the walkway.

The walkway floor drains may be freezing allowing water to

recommend that heat tape be applied to these drain pipes to keep the drains operational and to eliminate water intrusion at the drains.

The walkway door sill should be removed and adjusted to slope to the outside. Reinstall the sill in a full bed of mastic and sealed at the door frames with silicone sealant. Provide larger weatherstripping at the gap between the latch side of the door and adjacent frame. If necessary a flashing strip could be added to the exterior of the door to cover the gap.

Inspect, clean and close openings around and in all louver frames and all insulated metal panels, with continuous bead of silicone sealant.

Provide splash pan/block under the sanitary sewer vent then clean and repaint perimeter metal as necessary.

Repaint walls and ceiling of cab stairway.

6.2.3 Cable Access Level

Repair all damaged vapor barrier on the inside of the perimeter wall of the Cable Access Room, CA1.

Clean up and check for proper drainage at area drains around outer perimeter concrete slabs.

Verify that the control damper (CD-124) for the elevator shaft ventilation is a low leakage damper with insulated blades. If it is, verify proper operation. If not, it is recommended to replace it with a low leakage damper with insulated blades.

Verify that the control damper (CD-127) for the cab smoke exhaust system is a low leakage damper with insulated blades. If it is, verify proper operation. If not, it is recommended to replace it with a low leakage damper with insulated blades.

Repair insulation on elevator smoke relief duct and other ductwork as required.

6.2.4 Elevator Shaft

There are no recommendations for the interior of the elevator shaft. Recommendations on the exterior of the shaft are addressed on the individual floors as necessary.

6.2.5 Junction Level

Verify proper operation of HVAC system to eliminate the unusually high temperature (and humidity) in the area of the cab stairs and Locker Room.

In Room J10, replace the floor drain with a floor sink and properly direct all drain lines into the floor sink to prevent water from running onto the floor. Remove vinyl tile, clean floor and seal concrete floor with an epoxy type floor coating

In Room J12, replace floor drain with a floor sink (see catalog cut) and properly direct all drain lines into the floor sink to prevent water from running onto the floor. Identify and repair leaks in piping systems. Remove and replace insulation jacket on chilled water piping where exposed piping is subject to water condensation. Clean concrete floor and seal with an epoxy type floor coating

Room J14, Verify that the control damper in the stairwell is a low leakage damper. If it is, verify proper operation. If not, it is recommended to replace it with low leakage damper.

In the Smoking Room, provide proper weather-stripping and seals at Door J8.

Remove concrete topping/walking surface and waterproof membrane on all 4 walkways. Remove and replace walkway area drains with new drains. Clean and prepare concrete surface for new single-ply PVC roofing. Install tapered insulation and single-ply PVC roofing with proper flashing at base of insulated metal panels, storefront framing, and curbs at exterior and louver doors to microwave balconies. Install continuous sheet of walkway surface to protect roofing membrane. Provide proper flashing and waterproofing of the base of each guardrail post. Replace the narrow strip of sealant between the face of post and concrete curb with PVC compatible pitch pockets.

Based on FAA reports since the site visit we are assuming that the holes at the balcony guardrail posts have been sealed and do not contribute to water leaks any more.

Inspect entire storefront system on the Junction level and replace/repair all missing or damaged gaskets.

In Janitor Room #J11: provide the following:

- Remove vinyl tile flooring, clean concrete floor and seal concrete floor with an epoxy type floor coating with integral cove up to 4-inches AFF.
- Remove and replace service sink.
- Remove ceramic tile wainscot and gypsum wallboard on all 3 sides surrounding the service sink. Replace with cementitious backer board and new ceramic tile wainscot up to 7'-0" AFF.
- It is also recommended that a waterproof membrane be installed up to 48-inches minimum AFF over the metal studs in accordance with TCNA installation method W244.

6.2.6 Sub-Junction Level

Heat trace and insulate exposed drain pipes (from the Junction Level) in the unconditioned spaces where they are subjected to freezing temperatures. Reference photo 4.2.6-3.

Maintain cleanliness of floors in SJ6 and SJ8 to insure proper drainage to floor drains.

Rooms SJ6 and SJ8, install protective coating similar to Cafco Top-Cote by Isolatek International, applied per manufactures instructions and UL guidelines over existing fireproofing to help protect it from exposure to the elements due to being in the areas below grating on the Junction Level.

Room SJ7, verify that the control damper for SVF-1 is a low leakage damper with insulated blades. If it is, verify proper operation. If not, it is recommended to replace it with a low leakage damper with insulated blades. Clean and seal concrete floor with an epoxy type floor coating.

Room SJ1, replace floor drain below the raised floor with a floor sink (see catalog cut) and properly direct all drain lines into the floor sink to prevent water from running onto the floor. Since this is a concealed area we would also recommend the installation of a water/moisture sensor to detect any moisture on the area adjacent to the new floor sink.

To help insure that humidity levels are kept at the minimum levels required, it is recommended to install humidity sensors in

Room SJ1 with associated controls that will prevent the humidifier from operating above required levels.

To help minimize transmitting moisture vapor outside of Room SJ1, we recommend sealing all holes and penetrations in the walls below the raised floor, within the room and above the ceiling. All of these surfaces should then be painted with a good quality semi-gloss paint to help act as a vapor barrier.

Provide proper seals on access door SJ8.

Install access panel in ceiling of vestibule SJ4 to allow access to the plumbing for service sink on the Junction Level.

Due to the humidification that is added to the air on this level, it is a challenge to prevent that moist air from contacting the cold exterior concrete wall during the winter months. It is recommended that the perimeter area be heated to help raise the temperature of the concrete wall above the dew point and to install dehumidifiers to reduce the humidity in the air. We recommend the installation of 2 unit heaters on opposite sides of the tower and oriented to help circulate the heated air around the perimeter space. The dehumidifier has a built-in condensate pump which should be connected to the sanitary sewer line. See Appendix B for catalog cuts. The recommended locations for the unit heaters would be on the east and west sides of the tower, gaining access to the perimeter space through the recently installed access panels.

6.2.7 Eleventh Floor

Heat trace and insulate exposed drain pipes (from the Sub-Junction Level) in the unconditioned spaces where they are subjected to freezing temperatures. (Reference photo 4.2.6-8).

The preference would be to open this floor up by removing all of the walls. However, due to the requirement for floor-to-floor fire rating, it is not recommended to remove the perimeter shaft walls. Similarly, the functions in the various rooms do not allow for the 2-hour rated partition wall to be removed.

To prevent warm moist air from contacting the cold exterior pre-cast concrete walls, it is recommended that the perimeter area be heated to help raise the temperature of the concrete wall above the dew point and to install dehumidifiers to reduce the humidity in the air. The dehumidifier has a built in

sanitary sewer line in the plumbing chase. See Appendix B for catalog cuts. The recommended locations for the units would be on the south side of the stairway where there is approximately 6-feet between the shaft wall of the stairs and the exterior concrete wall.

6.2.8 Tenth Floor

As with the 11th Floor, the preference would be to open this floor up by removing all of the walls, but due to the requirement for floor-to-floor fire rating, it is not recommended to remove the perimeter shaft walls. However, since there are no functions in any of the rooms, it is recommended to remove all of the partitions and associated doors between Rooms TS1/TS3, TS3/TS4, TS4/TS5 and TS5/TS1. Additionally, the ceiling in the elevator lobby should be removed in conjunction with the removal of the walls. This will help improve air circulation and prevent stagnation between different spaces.

A rated enclosure with access doors would be required around the cable chase, extending from slab to slab. Verify that the integrity of the plumbing chase is maintained.

To reduce humidity, and therefore condensation on the walls, it is recommended to install a unit heater and dehumidifier in the newly created large open space. The dehumidifier has a built-in condensate pump which should be connected to the vertical sanitary sewer line in the plumbing chase. See Appendix B for catalog cuts.

Remove and replace sections of damaged drywall and wall base.

Provide control valve at the unit heater in stairway vestibule to prevent unnecessary hot water recirculation.

6.2.9 Ninth Floor through Fifth Floor

All of these floors are double height floors (23'-6"). It is recommended to remove all walls and doors creating rooms TS03, TS04 and TS05. To open up the remainder of the floor, the extension of the rated walls from the corners of the Stair Pressurization Shaft and the Smokeproof Vestibule Shaft to the concrete walls should be removed. A new 2-hour wall (Type-B) is required on the west side of the Smokeproof Vestibule

must be upgraded to a 2-hour wall. The Stairway Pressurization Shaft is already a 2-hour (Type B) rated enclosure. The only remaining walls would be the elevator shaft and the walls around the stairs and ventilation shafts. Finally, the ceiling in the elevator lobby should be removed in conjunction with the removal of the walls.

A rated enclosure with access doors would be required around the cable chase, extending from slab to slab. Verify that the integrity of the plumbing chase is maintained.

To prevent warm moist air from contacting the cold exterior pre-cast concrete walls, it is recommended that this newly created large open space be heated to help raise the temperature of the concrete wall above the dew point and to install dehumidifiers to reduce the humidity in the air. The dehumidifier has a built-in condensate pump which should be connected to the vertical sanitary sewer line in the plumbing chase. See Appendix B for catalog cuts.

Provide control valve at the unit heater in stairway vestibule to prevent unnecessary hot water recirculation.

In Room 6TS3, repair leaking end caps on hot water piping.

6.2.10 Fourth Floor

Replace the 4' x 7' louver in west wall with new storm resistant louver (see catalog cut). Install a metal pan below louver.

Repair the damaged access door to the intake louver to prevent air leakage. Seal gaps and insulate the access door

Remove wall between Rooms TS4 and TS5. Construct a rated enclosure with access doors around the cable chase, extending from slab to slab.

To reduce humidity, and therefore condensation on the walls, it is recommended to install a unit heater and dehumidifier in the newly created Room TS4/TS5. The dehumidifier has a built-in condensate pump which should be connected to the vertical sanitary sewer line in the plumbing chase. See Appendix B for catalog cuts.

Provide control valve at the unit heater in stairway vestibule to prevent unnecessary hot water recirculation.



Verify that that the control dampers (CD-120, CD-121, and CD-105) on the outside air intake louver are low leakage dampers. If they are, verify proper operation. If not, it is recommended to replace them with low leakage dampers.

6.2.11 Third Floor

Replace floor drain with a floor sink (see catalog cut) and properly direct all drain lines into the floor sink to prevent water from running onto the floor.

Seal concrete floor with an epoxy type floor coating.

Remove wall between Rooms TS4 and TS5. Construct a rated enclosure with access doors around the cable chase, extending from slab to slab.

Install a dehumidifier and connect the condensate pump drain to the new floor sink.

Provide control valve at the unit heater in stairway vestibule to prevent unnecessary hot water recirculation.

Room 3TS3, verify that control dampers (CD-104 and CD-115) for SVF-2 are low leakage damper with insulated blades. If they are, verify proper operation. If not, it is recommended to replace them with low leakage dampers with insulated blades.

6.2.12 Second Floor

In Room 2TS5, repaint the walls with water stains and replace stained or damaged ceiling tiles.

Provide control valve at the unit heater in stairway vestibule to prevent unnecessary hot water recirculation.

6.2.13 Ground Floor

Repair leaking pipes or valves at AHU-16. Check for condensation on exposed chilled water piping and replace insulation jacket if required.

6.3 Base Building

6.3.1 Exterior Conditions

Install a continuous metal flashing around the perimeter of the Base Building at the bottom of the sloped pre-cast panels to divert water away from the window at the head condition. It is especially important for this flashing to run continuously at the corners.

Since the FAA provided wet seals on all of the exterior windows, multiple leaking conditions appear to have been resolved. However, it is recommended that the FAA contact a specialty window/storefront consultant to evaluate the existing framing system and provide opinions and possible recommendations for the FAA's consideration.

All clamp attachments penetrating the storefront framing (e.g. down conductor conduits, antennas, etc.) should be tightened and properly sealed with silicone sealant. Additionally, penetrations/attachments to the pre-cast panels should be properly sealed with silicone sealant (e.g. bolts, telephone boxes, electrical outlets, etc.)

All exterior doors should receive new weather-stripping, seals and astragals (at double doors), with all door thresholds also being replaced. Care should be taken during the winter to prevent the build-up of snow against the doors. Examples of thresholds are located in Appendix B.

Replace missing or deteriorated gaskets at the Link storefront framing.

Provide proper seals between the entrance canopies and the Link curtain wall.

6.3.2 Roof

Fully inspect and replace/repair any fractured or deteriorated sealant in the pre-cast panels.

For both the high and low roof areas, it is recommended to remove all of the concrete pavers and the associated protection fabric. It is then recommended that the FAA contact a roofing consultant to conduct a thorough evaluate the exposed single-ply membrane and provide

is recommended, we suggest that the FAA consider the use of a PVC single-ply membrane in lieu of the EPDM single-ply membrane.

Repair and/or replacement of the roofing should also include the single-ply parapet flashing and removal of unused attachment clips.

We would recommend that the FAA consider only replacing the concrete pavers on the Link, which is the area most susceptible to falling ice and debris from the control tower.

Clean and reseal all roof drains. Repair/replace as recommended by the roofing consultant.

Provide new flashing boots at roof penetrations to extend a minimum of 8" above the roof surface.

We recommend increasing the curb height at the skylight to a minimum of 12" above the roof surface. Remove cover plates at skylight, reseal domes and reinstall metal cover plates.

Where the Link joins the control tower, after removal of concrete pavers, verify proper roof slopes and crickets for drainage.

6.3.3 Second Floor

Properly route pipes to floor sink under the raised floor in Room 204 to prevent the water from splashing/migrating onto the concrete floor. Since this is a concealed area we would also recommend the installation of a water/moisture sensor to detect any moisture on the area adjacent to the floor sink.

Replace stained ceiling tiles throughout Second Floor.

Repaint ceiling in Break Room due to numerous water stains.

As necessary in perimeter offices, remove and replace:

- Damaged gypsum wallboard. Replace with glass-matt faced gypsum wall board.
- Vinyl wall coverings. Replace with fabric wall covering.
- Plastic laminate window stools.
- Wall base.

6.3.4 First Floor

Replace stained ceiling tiles throughout First Floor.

Repair leaking pipes/valves above corridor near Room #126.

In Mechanical areas, globally inspect for and replace leaking pipes and valves. Additionally, provide or replace insulating jackets at areas of condensation.

As necessary in perimeter offices, remove and replace:

- Damaged gypsum wallboard. Replace with glass-matt faced gypsum wall board.
- Vinyl wall coverings. Replace with fabric wall covering.
- Plastic laminate window stools.
- Wall base.

In Janitor Room #134 provide the following:

- Remove vinyl tile flooring, clean concrete floor and seal concrete floor with an epoxy type floor coating with integral cove up to 4-inches AFF.
- Remove and replace service sink.
- Remove ceramic tile wainscot and gypsum wallboard for the entirety of the 2 walls adjacent to the service sink (approximately 10 lineal feet). Replace with cementitious backer board and new ceramic tile wainscot up to 7'-0" AFF.
- It is also recommended that a waterproof membrane be installed up to 48-inches minimum AFF over the metal studs in accordance with TCNA installation method W244.
- Relocate electrical receptacle around corner, closer to the door.

2

8

**Corpus Christi, Texas
Airport Traffic Control Tower
(CRP ATCT)**

Mold and Moisture Assessment

Conducted: November 14-15, 2007

Report Prepared By: Barbara Hebert, NISC CIH
Texas Department of State Health Services
Mold Assessment Consultant
License Number: MAC1025
Expiration Date: 9/20/2009

INTRODUCTION:

A mold and moisture assessment was conducted in the CRP ATCT, associated Base Building, and Environmental Services Unit (ESU) Building on November 14-15, 2007, as requested by Michelle Lott, Program Implementation Manager for Occupational Safety and Health (OSH) Compliance Programs. The assessment was performed jointly with Mr. Ed Winkler, Civil Engineer, Engineering Services.

Water damage and visible mold growth were discovered in various rooms of the ATCT, Base Building, and ESU Building, primarily caused by moisture infiltration through building panel sealants and/or window systems; condensation on chilled water pipe insulation and heating, ventilation, and air conditioning (HVAC) system ductwork; air infiltration; possible HVAC system deficiencies; and miscellaneous building leaks.

The evaluations conducted in the Base and ESU Buildings were limited in scope and were primarily a review of areas previously inspected and identified by All Points Environmental, LLC, Corpus Christi, Texas, during their September 12, 2007 assessment.

The evaluation was also limited in scope in that the investigation relied on visual observations made during a walkthrough of the facility and it focused on known problem areas or typical areas where problems have been found in similar facilities. Destructive or intrusive methods such as the large-scale removal of vinyl cove base, or core drilling and removing sections or various layers of gypsum board, were not utilized. At several suspect locations, the bottom of the vinyl cove base was pried loose enough to allow visual inspection yet not cause any cosmetic damage to the facility. In most cases, the gypsum board was found to be elevated slightly up from the floor slab, which generally eliminated the possibility of wicking up water.

Bulk samples were collected from suspect materials in two locations of the ATCT. Direct examination fungal analysis was performed by EMSL Analytical, Inc. This laboratory is accredited by the American Industrial Hygiene Association under the Environmental Microbiology Laboratory Accreditation Program (EMLAP). It is additionally accredited by the Texas Department of State Health Services (TDSHS).

As required by the TDSHS regulations, the findings from this document will be used to prepare a mold remediation protocol, whereby remediation methods, personal protective equipment, engineering controls, project layout, and post-remediation clearance evaluation methods and criteria will be specified.

FINDINGS:

The assessment findings are summarized as follows:

CAB LEVEL

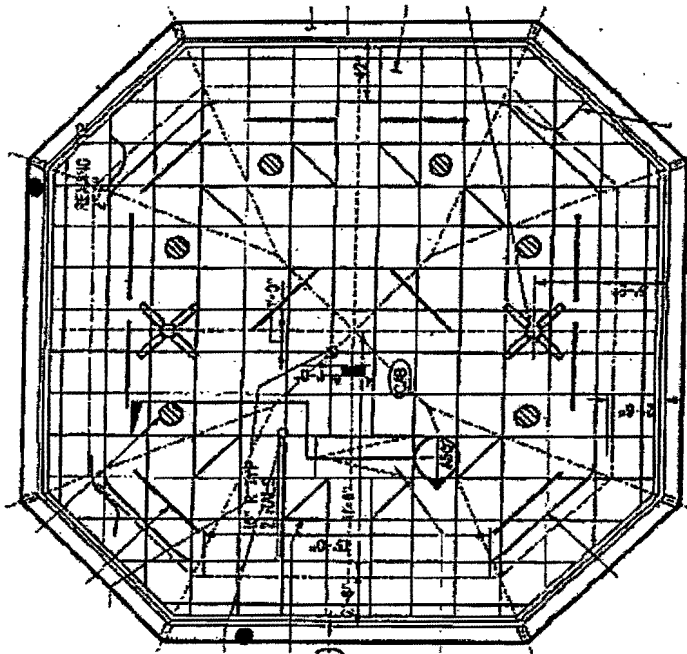

Contractor Action Required: •

Housekeeping Action Required: •

CABLE ACCESS LEVEL

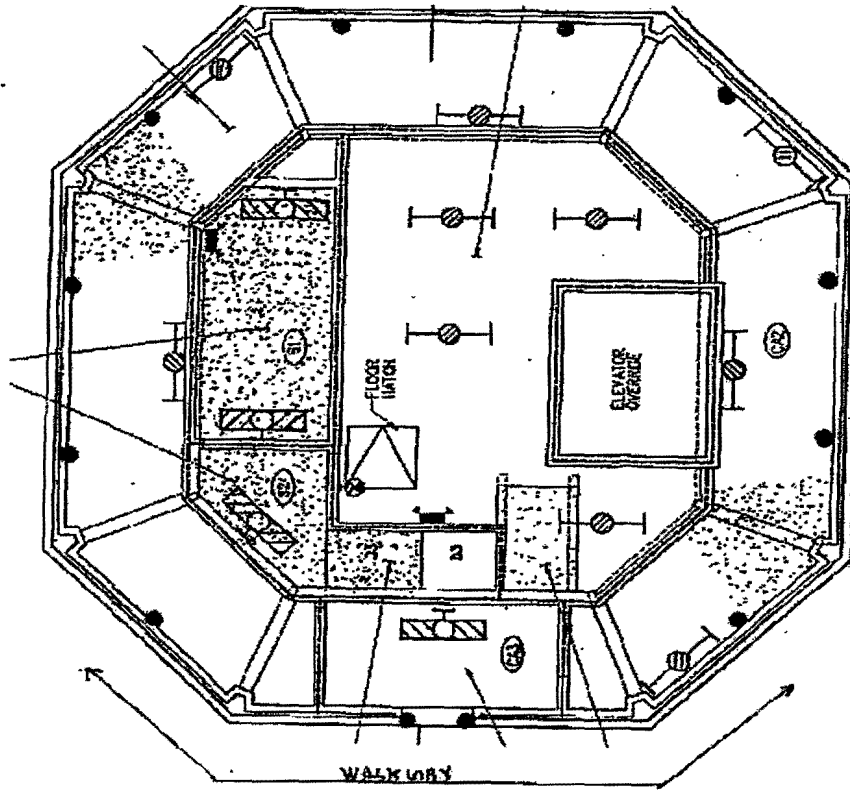

Contractor Action Required: •

Housekeeping Action Required: •

JUNCTION LEVEL

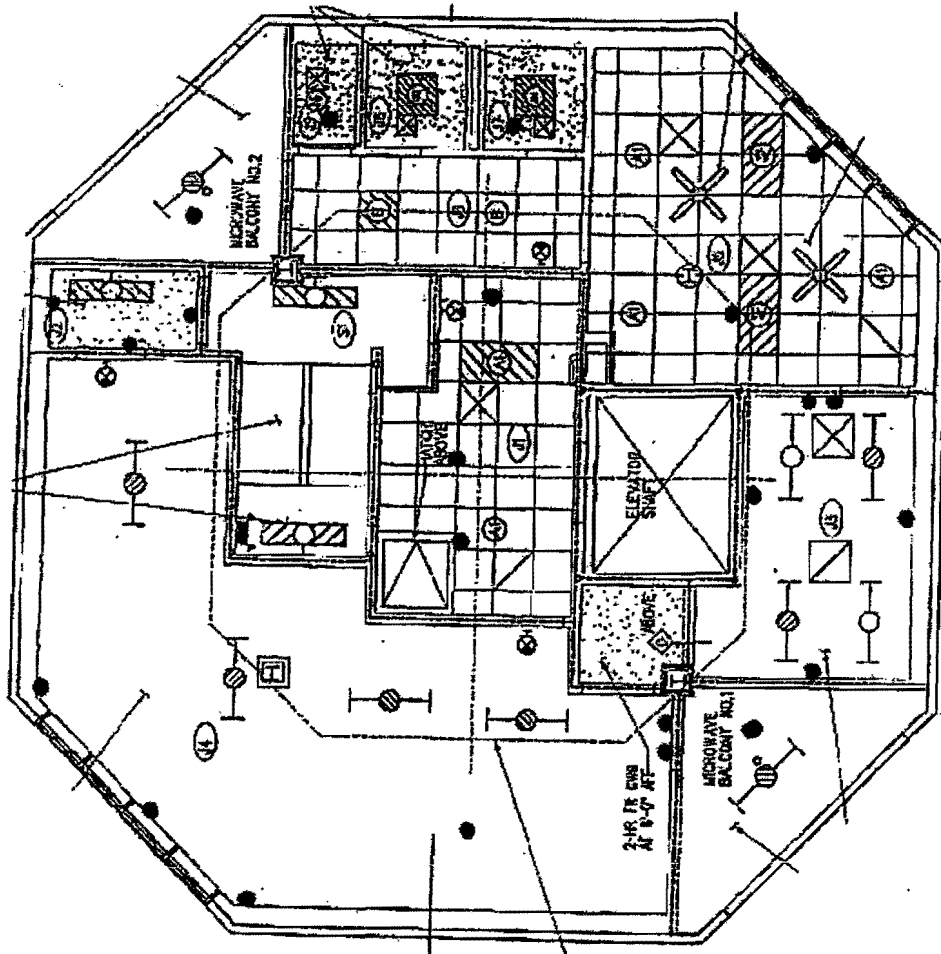

Contractor Action Required: •

Housekeeping Action Required: •

INTERMEDIATE LEVEL 3

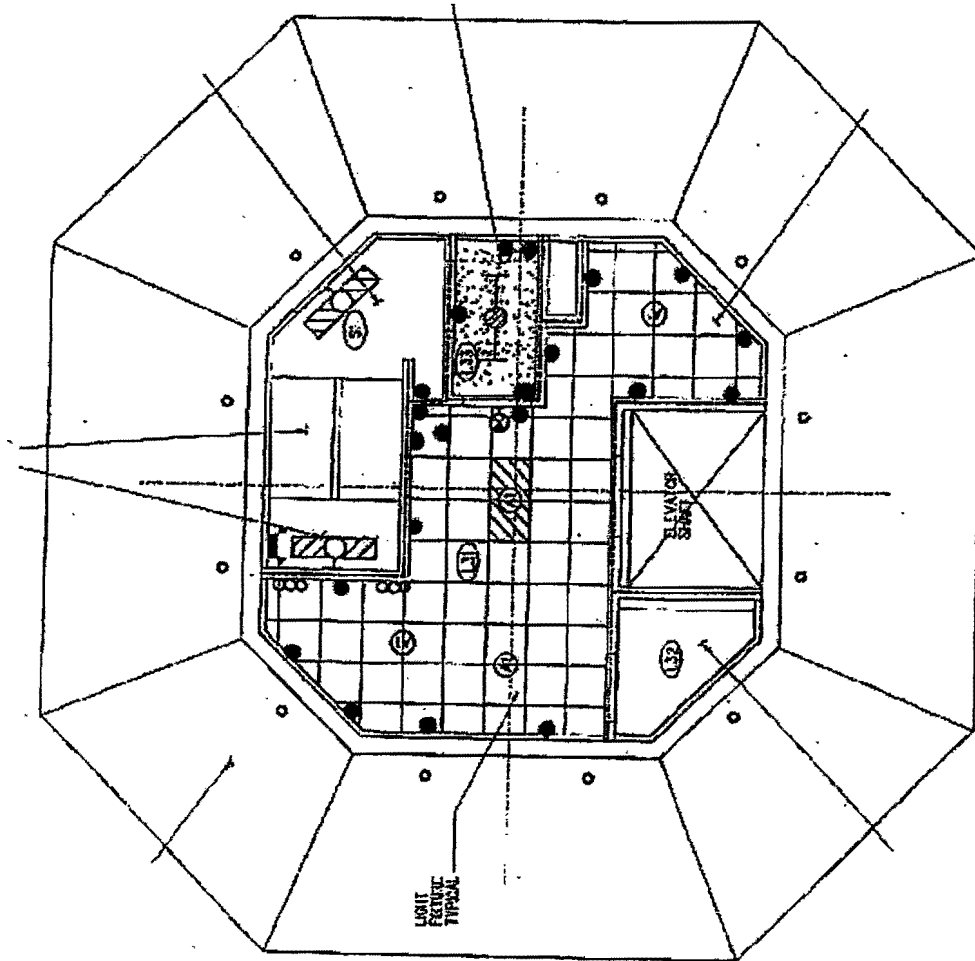

Contractor Action Required: •

Housekeeping Action Required: •

INTERMEDIATE LEVEL 2

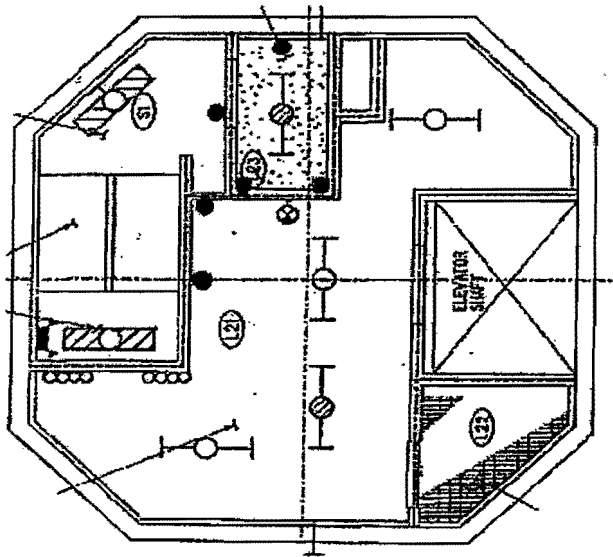

Contractor Action Required: •

Housekeeping Action Required: •

INTERMEDIATE LEVEL 1

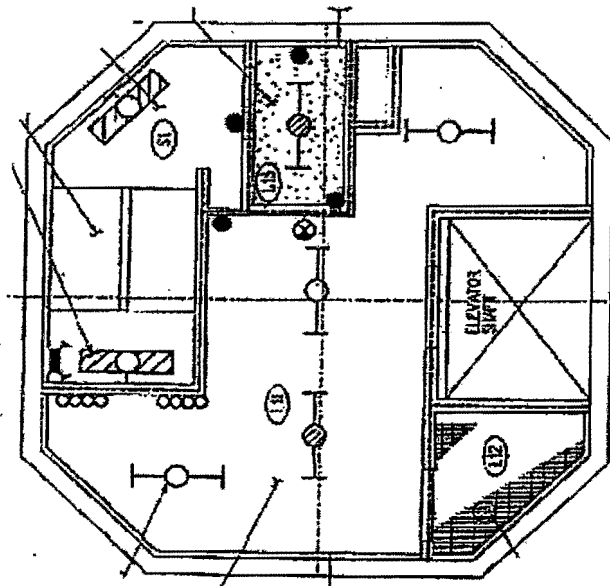

Contractor Action Required: •

Housekeeping Action Required: •

ROOF ACCESS LEVEL

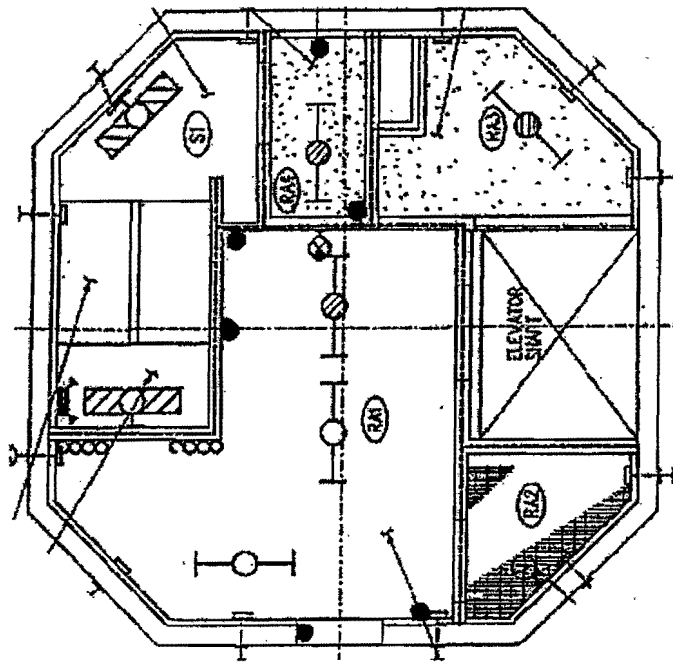

Contractor Action Required: •

Housekeeping Action Required: •

GROUND LEVEL

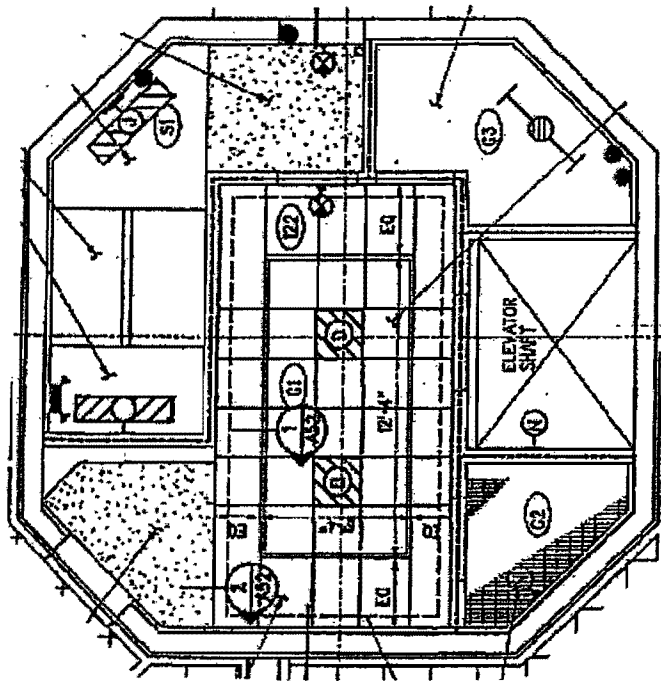

Contractor Action Required: •

Housekeeping Action Required: •

ATCT FINDINGS:

Control Cab Roof - All sealant at joints in the metal cap flashing at the roof perimeter showed signs of excessive deterioration such as cracking. Sealant failure at this location could contribute to leaks in the control cab wall system. Sealant at the perimeter of the through wall hood at the penthouse showed signs of failure. The joint between the bottom of the insulated metal panels and the base flashing was filled with sealant. Typically this joint is open to direct water in the panel seams to the exterior. As installed, water could be trapped in the wall system.

Control Cab - Staining was observed on Window #10 mullions. Air Traffic personnel reported that repeated water leaks have occurred in this area for six or more months and the Break Room on the Junction Level has had leaks for at least the past two years. Staining was observed on the glass by Window #7 and Window #8 mullions.

Room CA1 - No moisture related issues or mold were observed in this room.

Room CA2 - Water stains and mold were observed on the walls and behind the vinyl cove base throughout this area, with the heaviest damage noted by the column enclosures. In the unfinished/unconditioned space around the exterior perimeter, significant mold, water damaged insulation, and rust and water corroded metal studs were observed.

Room CA3 - Water stains and mold were observed on the walls and behind the vinyl cove base throughout this area. In the unfinished/unconditioned space around the exterior perimeter, significant mold, water damaged insulation, and rust and water corroded metal studs were observed. Water damage was observed on both sides of the door to the outside walkway.

Cable Access Level Exterior Walkway - Severely deteriorated sealant was observed in all joints between all precast panels. The lightning protection cables penetrated vertical caulk joints between precast panels at the surface of the walkway in two places. A pipe or conduit cast into the walkway was cut off flush with the walkway and the waterproof coating was peeling at this location and others on the walkway. Cracks were observed where the walkway surface intersected the vertical parapet wall. Penetrations of the interior walkway wall, such as junction boxes, were not adequately sealed along the top or sides. The threshold did not appear to have adequate sealant between it and the concrete below or at the intersection with the doorframe outside the stops. The slope of the threshold toward the exterior appeared minimal. These items all contribute to the leaks at this level and below.

Cab Level Stairs - Heavy dust was observed on the return air vent.

Room J1 Lobby - Five stained ceiling tiles were observed in this room. The source of the moisture may have been from condensation on HVAC ductwork or a water leak from the floor above that dripped onto the ductwork and down to the ceiling. Two stained egg-crate panels were observed in this room. The source of the staining was determined to be oil from a hydraulic hatch above.

Dirty supply and return air diffusers and grilles were observed in this room.

Room J2 - Yellow staining and mold were observed on the entire west wall and a portion of the gypsum board ceiling in the southwest corner of the room. A small band of mold was found on the east wall on both sides of the doorframe. Mold was observed on chilled and heating water supply and return pipe insulation; on fan coil unit #8; and on the door to Room J4.

Room J3 - Heavy water stains and mold were found on the east wall, behind the vinyl cove base, and below the raised floor. Water stains and discoloration were found on the floor covering near the door to Room J5 and the doorframe showed some rusting at the floor line from water exposure. Discolored and spotted areas were observed on the south, west, and north walls below the raised floor and a bulk sample was collected. A minor trace of mold was detected. Mold was found on the chilled water pipe insulation below the raised floor.

Room J4 - Mold was observed on the chilled water supply and return pipe insulation; HVAC units #2 and #3 and ductwork; and on the east door to Microwave Balcony #1. Mold and dust were observed on fan coil units #12 and #13. Mold was observed on the entire east wall on both sides and above the door. Mold was observed on the southwest wall behind the vinyl cove base below the outside louver panels. The lockset on the door to the Microwave Balcony #1 was broken and

did not latch, which allows outside air into the room.

Microwave Balcony #1 - Excessive amounts of nesting materials and bird droppings were observed. These items can be food sources for mold and can cause other health problems.

Microwave Balcony #2 - Excessive amounts of nesting materials and bird droppings were observed. These items can be food sources for mold and can cause other health problems.

Room J5 - Water stains and residue were found on the east window mullions, framing, and wooden sill. Two stained ceiling tiles were observed in this room. The source of the moisture may have been from the fire protection water line above or condensation from the HVAC ductwork. Numerous ceiling tiles had been removed apparently due to past leaks and several trash cans were in place to catch leaks. The hot and cold water shut off valves in the sink base cabinet showed signs of corrosion and past leaks.

Room J7 - All walls and floor in this room are ceramic tile. Water stains and puckering were observed on the gypsum board ceiling between the supply and return air vents.

Room J8 - All walls and floor in this room are ceramic tile. No damage was observed on the gypsum board ceiling.

Room J9 - All walls and floor in this room are ceramic tile. Puckering was observed on the gypsum board ceiling between the supply and return air vents.

Room L31 - Water stains were observed on the west wall and on the portion of the north wall between the west wall and the door to Room L33. A small amount of surface mold was found on the west wall, on top of and on the sides of, the fire extinguisher panel. Spotted areas were observed on all of the walls below the raised floor except the east side at the cable chase and elevator shaft. A bulk sample was collected of this spotted material on the west wall below the raised floor, directly below the fire extinguisher panel. A small amount of mold was detected. Three stained ceiling tiles were observed in this room. Based on information provided by local facility personnel, the source of the moisture was due to a past leak that had since been repaired.

Room L33 - A stripe of mold was observed on the south wall on the east side of the door to Room L31, which extended onto the east wall for the entire height of the door. Mold was found on the south, east, and north walls below the raised floor. Mold was found on the door to the stairwell lobby and on fan coil unit #7.

Level 3 Stairwell Landing - Mold was found on the wall and behind the vinyl cove base in the recess south of the door to Room L33.

Level 2 Stairwell Landing - Mold was observed on the door and frame to Room L23.

Room L23 - Spots of mold were observed on the south wall above and on both sides of the door to Room L21. The mold on the wall extended onto the adjacent east and west walls. Mold was found on the door to Room L21. Mold was observed on the chilled water supply and return pipe insulation. Mold was found on fan coil unit #6.

Room L21 - Yellow rust stains were observed on the west wall and the portion of the north wall between the west wall and the door to Room L23. Peeling paint was observed on the west wall. Mold was observed on the chilled water supply and return pipe insulation.

Level 1 Stairwell Landing - Mold was observed on the door and frame to Room L13.

Room L13 - A stripe of mold was observed on the south wall on the east side of the door to Room L11, which extended onto the east wall. Mold was observed on the chilled water supply pipe insulation. Dust was found on fan coil unit #5.

Room L11 - Water stains were observed on the north wall between the west wall and the door to Room L13. Mold was observed on the overhead portions of the chilled water supply and return pipe insulation.

Room RA1 - Yellow stains and mold were found on the west wall from the vinyl cove base up to the fire extinguisher cabinet. Water stains and mold were observed on the portion of the north wall between the west wall and the door to Room RA4. Water stains and peeling paint were observed on the portion of the west wall in the recess at the door to the roof. Rust debris was present on the floor and a small amount of mold was observed behind the vinyl cove base on the portion of the

south wall by the door to Room RA2. Mold was observed on the chilled water supply and return pipe insulation.

Room RA4 - A stripe of mold was observed on the south wall on the east side of the door to Room RA1, which extended onto the east wall for the entire height of the door. Mold was observed on the chilled water supply and return pipe insulation. Mold was found on fan coil unit #3.

Ground Level Stairs - Mold was observed on the west wall in the recess to the outside door #105, on the adjacent north wall, and on the entire northwest wall.

Pump Room G3 - Mold was observed on the east wall and behind the vinyl cove base. Yellow stains and mold were observed on the northeast wall and behind the vinyl cove base.

ATCT Stairs S1 - Dust was observed on all of the stair stringers throughout the stairwell.

ATCT ACTION:

Contractor: •

Control Cab and Room J5 - Evaluate and determine the source of the moisture infiltration by the windows.

Room CA2 - Remediate and restore approximately 480 square feet of gypsum board along the entire perimeter of this room.

Room CA3 - Remediate and restore approximately 60 square feet of gypsum board along the entire perimeter of this room. Remediate and restore approximately 6 square feet of gypsum board on both sides of the door to the outside walkway.

Cab Level Stairs - Clean return air vent by high efficiency particulate air filter (HEPA) vacuuming followed by damp wiping with a detergent solution.

Room J2 - Remediate and restore approximately 29 square feet of gypsum board on the entire west wall. Remediate and restore approximately 25% of the gypsum board ceiling in the southwest corner of the room near the chilled water and heating water pipe insulation. This ceiling has a 2-hour rating. The removal of multiple layers of gypsum board may be required. Remediate and restore approximately 5 square feet of gypsum board on both sides of the door to S1. Remediate and restore all contaminated chilled and heating water supply and return pipe insulation. Clean the surface of fan coil unit #8 by HEPA vacuuming followed by damp wiping with an approved cleaning solution. Clean the surface of the door to Room J4 by damp wiping with an approved cleaning solution.

Room J3 - Remediate and restore approximately 140 square feet of gypsum board on the east wall, from the floor to the underside of the beam. Clean the surfaces on the south, north, and west walls below the raised floor by damp wiping with an approved cleaning solution. Remediate and restore all contaminated chilled water pipe insulation.

Room J4 - Remediate and restore approximately 68 square feet of gypsum board on the east wall (surface layer) on both sides and above the door to Microwave Balcony #1. Inspect concealed layer or assume an additional quantity is also contaminated. Remediate and restore approximately 8 square feet of gypsum board on the southwest wall below the outside louvers. Remediate and restore approximately 0.25 square feet of gypsum board on the south wall behind the vinyl cove base next to fan coil unit #13. Remediate and restore all contaminated chilled water supply and return pipe insulation. Clean the surfaces of HVAC units #2 and #3 and approximately 30 linear feet of ductwork by damp wiping with an approved cleaning solution. Clean the surfaces of fan coil units #12 and #13 by HEPA vacuuming followed by damp wiping with an approved cleaning solution. Clean the east door to Microwave Balcony #1 by damp wiping with an approved cleaning solution.

Microwave Balcony #1 - Clean floors by HEPA vacuuming followed by damp wiping with an approved cleaning solution. Initiate bird exclusion measures.

Microwave Balcony #2 - Clean floors by HEPA vacuuming followed by damp wiping with an approved cleaning solution. Initiate bird exclusion measures.

Room J7 - Repair or replace water damaged gypsum board ceiling.

Room J9 - Repair or replace water damaged gypsum board ceiling.

Room L31 - Clean the entire west wall, both above and below the raised floor, by damp wiping with an approved cleaning solution. Clean the north wall, between the west wall and door to Room L33, by damp wiping with a detergent solution.

Room L33 - Remediate and restore approximately 5 square feet of gypsum board on the entire south wall below the raised floor. Inspect concealed layer or assume an additional quantity is also contaminated. Remediate and restore approximately 4 square feet of gypsum board on the east wall below the raised floor, beginning in the southeast corner and extending to the west. Inspect concealed layer or assume an additional quantity is also contaminated. Remediate and restore approximately 1.5 square feet of gypsum board on the north wall below the raised floor, beginning in the northeast corner and extending from the corner joint to stud. Remediate and restore approximately 0.7 square feet of gypsum board on the south wall on the east side of the door to Room L31 above the raised floor, between the southeast corner and doorframe. Inspect concealed layer or assume an additional quantity is also contaminated. Remediate and restore approximately 10 square feet of gypsum board on the east wall above the raised floor, from the southeast corner to next stud. Inspect concealed layer or assume an additional quantity is also contaminated. Clean the surface of fan coil unit #7 by HEPA vacuuming followed by damp wiping with an approved cleaning solution. Clean the door to the stairwell lobby by damp wiping with an approved cleaning solution.

Level 3 Stairwell Landing - Remediate and restore approximately 25 square feet of gypsum board in the recess south of the door to Room L33.

Level 2 Stairwell Landing - Clean the contaminated surfaces on the door and frame to Room L23 by damp wiping with an approved cleaning solution.

Room L23 - Remediate and restore approximately 1.4 square feet of gypsum board on the south wall above and on both sides of the door, between the southeast corner and doorframe, the southwest corner and doorframe, and between the ceiling and doorframe. Inspect concealed layer or assume an additional quantity is also contaminated. Remediate and restore approximately 10 square feet of gypsum board on the east wall, floor to ceiling from the southeast corner to next stud. Inspect concealed layer or assume an additional quantity is also contaminated. Remediate and restore approximately 10 square feet of gypsum board on the west wall, floor to ceiling from the southwest corner to next stud. Inspect concealed layer or assume an additional quantity is also contaminated. Remediate and restore all contaminated chilled water supply and return pipe insulation. Clean the surface of fan coil unit #6 by HEPA vacuuming followed by damp wiping with an approved cleaning solution. Clean the contaminated surface on the door to Room L21 by damp wiping with an approved cleaning solution.

Room L21 - Clean the entire west wall and portion of the north wall between the west wall and door to Room L23 by damp wiping with a detergent solution. Remediate and restore all contaminated chilled water supply and return pipe insulation. Remove peeling paint on west wall, patch and repaint.

Level 1 Stairwell Landing - Clean the contaminated surfaces on the door and frame to Room L13 by damp wiping with an approved cleaning solution.

Room L13 - Remediate and restore approximately 0.7 square feet of gypsum board on the south wall on the east side of the door to Room L11 between the southeast corner and doorframe. Inspect concealed layer or assume an additional quantity is also contaminated. Remediate and restore approximately 10 square feet of gypsum board on the east wall, floor to ceiling, from the southeast corner to next stud. Inspect concealed layer or assume an additional quantity is also contaminated. Remediate and restore all contaminated chilled water supply pipe insulation. Clean the surface of fan coil unit #5 by HEPA vacuuming followed by damp wiping with a detergent solution.

Room L11 - Clean the portion of the north wall between the west wall and door to Room L13 by damp wiping with a detergent solution. Remediate and restore all contaminated chilled water

supply and return pipe insulation.

Room RA1 - Remediate and restore approximately 28 square feet of gypsum board on the entire west wall. Inspect concealed layer or assume an additional quantity is also contaminated. Remediate and restore approximately 9 square feet of gypsum board on the north wall between the west wall and the door to Room RA4. Inspect concealed layer or assume an additional quantity is also contaminated. Remediate and restore approximately 2 square feet of gypsum board on the portion of the south wall between the door to Room RA2 and the door to the roof. Clean the portion of the west wall in the recess at the door to the roof with a detergent solution. Remediate and restore all contaminated chilled water supply and return pipe insulation.

Room RA4 - Remediate and restore approximately 0.7 square feet of gypsum board on the south wall on the east side of the door to Room RA1 between the southeast corner and doorframe. Inspect concealed layer or assume an additional quantity is also contaminated. Remediate and restore approximately 10 square feet of gypsum board on the east wall from the southeast corner to next stud. Inspect concealed layer or assume an additional quantity is also contaminated. Remediate and restore all contaminated chilled water supply and return pipe insulation. Clean the surface of fan coil unit #3 by HEPA vacuuming followed by damp wiping with an approved cleaning solution.

Ground Level Stairs - Remediate and restore approximately two square feet of gypsum board on the west wall in the recess to the outside door #105, approximately 11 square feet on the adjacent north wall, and approximately 19 square feet on the entire northwest wall.

Pump Room G3 - Remediate and restore approximately 7 square feet of gypsum board on the east wall. Remediate and restore approximately 33 square feet of gypsum board on the northeast wall.

ATCT Stairs - Clean all stair stringers by HEPA vacuuming followed by damp wiping with a detergent solution.

Housekeeping: •

Room J1 - Remove and replace damaged ceiling tile. Additional investigation is required to determine the source of the moisture. Clean oil stains from egg-crate panels by damp wiping with a detergent solution. Clean supply and return air diffusers and grilles by damp wiping with a detergent solution.

Room J3 - Clean floor covering near the door to Room J5 by damp wiping with a detergent solution.

Room J4 - Repair lockset on east door to Microwave Balcony #1.

Room J5 - Remove and replace damaged ceiling tile. Additional investigation is required to determine the source of the moisture.

Room L31 - Remove and replace damaged ceiling tile. Local facility personnel reported that the cause of the moisture has been corrected therefore, no further Contract repair is required.

ATCT - Clean all windows and framing to remove staining and verify if leaks still exist.

BASE BUILDING

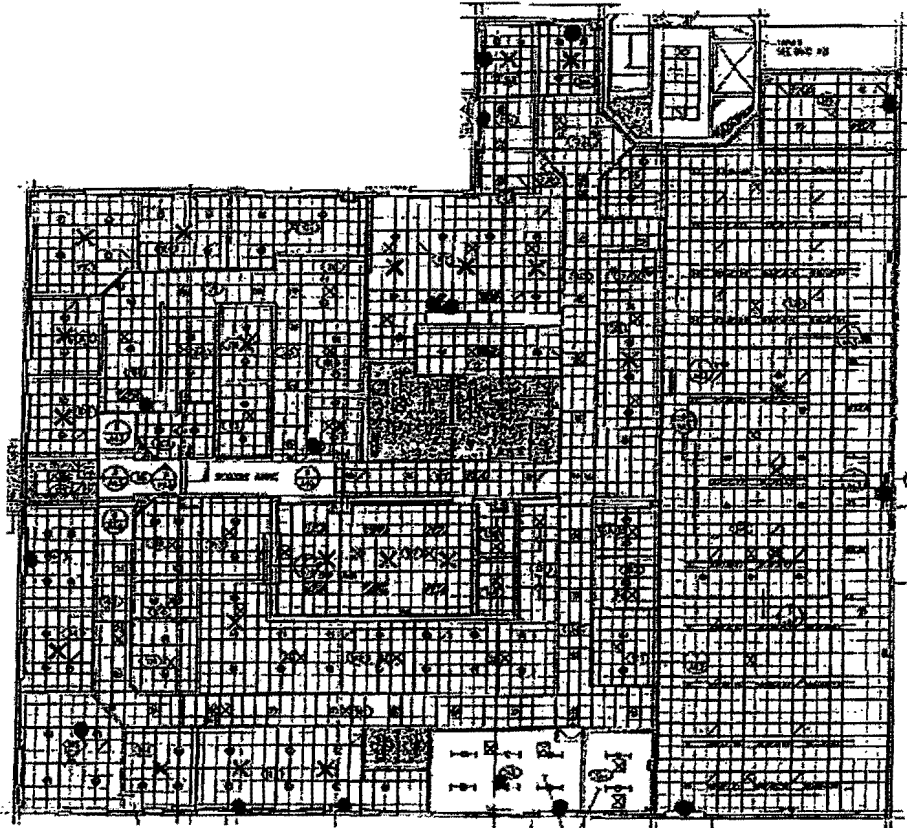

Contractor Action Required: •

Housekeeping Action Required: •

BASE BUILDING FINDINGS:

By entrance to Room 102 - Four stained ceiling tiles were observed in this area. The source of the moisture may have been from building leaks into the skylight.

Room 112 - Two stained ceiling tiles were observed in this room. The source of the moisture may have been from condensation from the HVAC ductwork.

Room 122 - An active water leak was found under the sink in this room. Water was standing on the base of the cabinet and mold and water damage were visible on the bottom and back of the cabinet. Items stored under the sink were wet. The drain and water lines were inspected. The leak was traced to the sprayer and flexible hose attached to the faucet. The leak was at the base of the sprayer and water was found to drip at this connection any time the water was turned on to the faucet. Facility personnel were informed of the problem and the need for immediate attention.

Room 124 - Water stains were observed on the north window glass and framing.

Room 129 - Water stains were observed on the west window mullion and framing.

Room 131 - Water stains and mold were observed on the south and east outside doors.

Room 132 - Water stains and mold were observed on the east outside door. Mold was observed on the doorframe where the weather stripping seal had deteriorated and left gaps.

Room 142 - Water stains and mold were observed on the south outside door and on the ductwork for air handling unit (AHU) #1. Mold was observed on the chilled water supply and return pipe insulation. Water stains were found on drain pipe insulation.

Room 143 - Mold was observed on both exterior doors and frames.

Room 145 - Two stained ceiling tiles were observed in this room, one of which was very large and one was very small. The source of the moisture for the large stain was a leak on the heating water piping. The source of the moisture for the small stain appeared to be condensation where the ductwork transitions from being insulated on the outside to being internally insulated.

Room 147 - Water stains were observed on the carpet under the plants.

Room 156 - Water stains were observed on the west window glass and framing and on the outside door glass and framing.

BASE BUILDING ACTION:

Contractor: •

Rooms 124, 129, and 156 - Evaluate and determine the source of the moisture by the windows.

Room 122 - Remove the back and bottom of the cabinet to inspect the concealed gypsum board. If contamination is found, remediate and restore approximately four square feet behind the sink on the south wall. If visible mold is found on the underside of the bottom and/or rear of the back panel of the cabinet, remove contaminated components and replace if the vast majority of the cabinet can be salvaged. Otherwise, discard the cabinet and replace in its entirety.

Room 131 - Clean the contaminated surfaces on the south and east outside doors by HEPA vacuuming followed by damp wiping with an approved cleaning solution. Replace and add additional weather stripping.

Room 132 - Clean the contaminated surfaces on the east outside door and frame by HEPA vacuuming followed by damp wiping with an approved cleaning solution. Replace weather stripping.

Room 142 - Clean the contaminated surfaces on the south outside door and AHU #1 ductwork by HEPA vacuuming followed by damp wiping with an approved cleaning solution. Remediate and restore all contaminated chilled water supply and return pipe insulation. Remove and replace stained drain pipe insulation.

Room 143 - Clean the contaminated surfaces on the exterior doors and frames by HEPA vacuuming followed by damp wiping with an approved cleaning solution.

Housekeeping: •

By entrance to Room 102 - Remove and replace damaged ceiling tile. Cause could not be determined, however, roof leak on skylight could be the source of the moisture. Check skylight for leaks during rains (especially heavy or driving rains) or water test and inspect. After replacement of tiles, observe for signs of leaks and if any appear, inspect ductwork, roof, etc., for cause.

Room 112 - Remove and replace damaged ceiling tile. Cause could not be determined. After replacement of tiles, observe for signs of leaks and if any appear, inspect ductwork, roof, etc., for cause.

Room 122 - Repair active leak on spray attachment for the Break Room faucet.

Room 145 - Remove and replace damaged ceiling tile. The source of the moisture has been corrected for one of the areas. Repair leaks in heating water piping. Observe ductwork and determine if condensation occurs where there is a transition from an externally insulated duct to an insulated duct.

Room 147 - Steam clean carpet and install drip pan under plants. Minimize water usage.

Base Building - Clean all windows and framing to remove staining and verify if leaks still exist.

ESU BUILDING

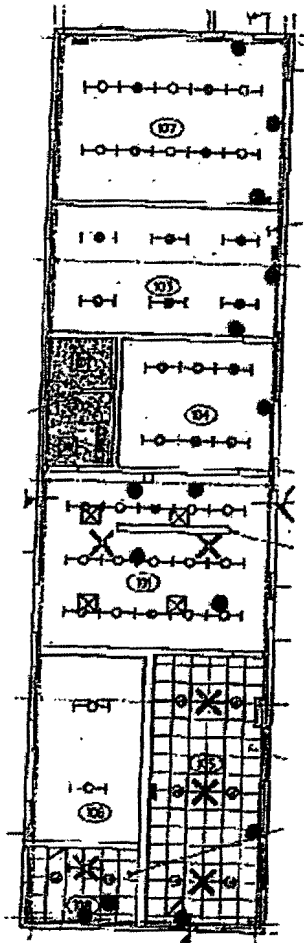

Contractor Action Required: •

Housekeeping Action Required: •

ESU BUILDING FINDINGS:

Room 101 - Mold was observed on the air diffusers, on HVAC ductwork, on the door to Room 104, and on the left side and below the sink. Mold was observed on the chilled water supply and return pipe insulation. Mold was observed on the heating water supply and return pipe insulation near the entrance to Room 104.

Room 103 - A small amount of mold was observed on the east outside door and on the door to Room 104. Mold was observed on all of the chilled water supply and return pipe insulation.

Room 104 - A small amount of mold was observed on the east outside door. Mold was observed on the chilled water return pipe insulation above CRU #5.

Room 105 - Water stains were observed on the south window glass and framing. One window insulated glass unit was broken. The wallpaper was puckered in the southwest corner by the window frame near the floor. Mold was observed on three air diffusers by perimeter walls. Mold was observed on the chilled water supply and return pipe insulation.

Room 107 - A small amount of mold was observed on the east and north outside doors. A water stain was observed on the door to Room 103.

Room 108 - Mold was observed on the air diffusers by the south and west walls. A stained ceiling tile was observed in this room. The source of the moisture may have been from condensation from the mold-contaminated chilled water return pipe insulation directly above this area.

ESU BUILDING ACTION:

Contractor: •

Room 101 - Clean the contaminated surfaces on the air diffusers, on the HVAC ductwork, on the door to Room 104, and surrounding the sink by HEPA vacuuming followed by damp wiping with an approved cleaning solution. Remediate and restore all contaminated chilled and heating water supply and return pipe insulation. Inspect heating water insulation at through wall penetration and seal penetration to prevent air movement from Room 104 to Room 101.

Room 103 - Clean the contaminated surfaces on the east outside door and on the door to Room 104 by HEPA vacuuming followed by damp wiping with an approved cleaning solution. Remediate and restore all contaminated chilled water supply and return pipe insulation.

Room 104 - Clean the contaminated surface on the east outside door by HEPA vacuuming followed by damp wiping with an approved cleaning solution. Remediate and restore all contaminated chilled water return pipe insulation. Fully insulate valve to prevent condensation. Allow reentry to access balancing valve.

Room 105 - Clean the contaminated surfaces on the air diffusers by HEPA vacuuming followed by damp wiping with an approved cleaning solution. Remediate and restore all contaminated chilled water supply and return pipe insulation. Evaluate and determine the source of the moisture by the window. Since it is likely that additional contamination will be found after the wallpaper is removed, replace all gypsum board in contact with the window framing with a paperless gypsum board, and terminate it with J molding and a gap at the window framing filled with sealant. Replace broken insulated glass unit in window.

Room 107 - Clean the contaminated surfaces on the east and north outside doors by HEPA vacuuming followed by damp wiping with an approved cleaning solution. Clean the water stained surface on the door to Room 103 by damp wiping with a detergent solution.

Room 108 - Clean the contaminated surfaces on the air diffusers by HEPA vacuuming followed by damp wiping with an approved cleaning solution. Remediate and restore all contaminated chilled water supply and return pipe insulation. Remove all of the wallpaper on the exterior walls and evaluate for mold and moisture.

Housekeeping: •

Room 108 - Remove and replace damaged ceiling tile. Additional investigation is required to

determine the source of the moisture.

ESU Building - Clean all windows and framing to remove staining and verify if leaks still exist.

CONCLUSIONS/RECOMMENDATIONS:

Water damage and visible mold growth were discovered in various rooms of the ATCT, Base Building, and ESU Building, primarily caused by moisture infiltration through building panel sealants and/or window systems; condensation on chilled water pipe insulation and heating, ventilation, and air conditioning (HVAC) system ductwork; air infiltration; possible HVAC system deficiencies; and miscellaneous building leaks.

It is recommended that sealant repairs be made to the exterior concrete panels and that, windows, window systems, and door seals be evaluated in order to eliminate future moisture intrusion issues.

It is recommended that the contaminated areas found during this evaluation be remediated in accordance with the guidelines established by the New York City Department of Health for the Assessment and Remediation of Fungi in Indoor Environments (GARFIE), the Central Service Area Guidelines for Managing Mold in FAA Facilities, issued June 13, 2006, and "FAA Guidance for Mold in FAA Facilities", issued September 25, 2006.

Attachment 1

**EMSL Analytical, Inc. Mold Spore Bulk Analysis
Report**



EMSL Analytical, Inc.

2501 Central Parkway, Suite C-17 Houston, TX 77092
Phone: (713) 686-3625 Fax: (713) 686-3645 Email: hn.stambaugh@emsl.com

Attn: Barbara Hebart
Federal Aviation Administration
901 Locust
Room 200-A
Kansas City, MO 64138
Proj: CRP ATCT Wood

EMSL Order: 150708538
Customer ID: FAAM78
Received: 11/20/17
Analyzed: 11/27/17
Reprint Date: 11/27/17

Microscopic Examination of Fungal Spores, Fungal Structures, Hyphae, and Other Particulates from Bulk Samples (EMSL Method: M041)

Table with columns for Lab Sample Number, Client Sample ID, Sample Location, Spore Types, and Category. Rows include various fungal species like Alternaria, Aspergillus, and Penicillium.

Category Counts: None 1 to 10 Low 11 to 100 Medium 101 to 1000 High >1000

No discernable field blank was submitted with this group of samples.

* Sample contains fruiting structures and/or hyphae associated

Melanie Rich

APPENDIX 2 - MICROSCOPIC METHODS

This document contains the procedures used for the microscopic examination of bulk samples. The procedures are subject to change without notice. The procedures are subject to change without notice. The procedures are subject to change without notice.

Document 7.7.3

For information on the fungi listed in this report please visit the Resources section at www.emsl.com

29

CORPUS CHRISTI ATCT MOLD & MOISTURE ENGINEERING ANALYSIS

From: Ed Winkler, Civil Engineer, Infrastructure Support center – Kansas City
To: Richard Beyer, Acting Supervisor, Infrastructure Support center – Kansas City
Date: December 18, 2007
Subject: Trip to CRP ATCT to evaluate mold and moisture problems at the facility.

EXECUTIVE SUMMARY

A mold and moisture assessment was conducted at the Corpus Christi, TX (CRP) ATCT on November 14 – 15, 2007. The inspection included the ATCT, Base building, and ESU Building. The inspection focused primarily on areas with known problems that had been identified in a report prepared by All Points Environmental, LLC, based on their September 12, 2007 inspection and assessment of the facility. This inspection also focused on areas of the facility where it seemed likely to find problems based on previous inspections of similarly constructed facilities.

The inspection was limited to a visual inspection and observation of surfaces, building materials, and conditions visible throughout the facility. Due to time constraints, the inspection in the Base Building focused on problem areas identified in the All Points Environmental report.

Destructive or intrusive inspection methods such as core drilling or removing sections or various layers of gypsum board or extensive removal of vinyl cove base were not utilized. This will require some assumptions to be made regarding the quantity of affected materials requiring remediation.

The FINDINGS AND CONCLUSIONS section provides a summary of the more significant or typical problems found. It does not provide a detailed description of the findings on a room by room basis. This information is contained in the assessment report included in the appendix (Attachment 1). Photographs taken during the inspection and a narrative of the findings are included in the appendix (Attachment 2). The RECOMMENDATIONS section provides a listing of the actions required to address the more significant items on an individual basis. Additional resources will be required to fully evaluate the extent of the problem, to determine all the causes for moisture related problems, and to identify the best and most cost effective methods to address the problems. For example, it is recommended that outside consultants be utilized to perform various tasks, such as to document problems with existing window systems or to document problems with the design, performance, and operation of the HVAC system and controls. This analysis provides recommendations and rough order magnitude costs based on the inspection teams on site observations and knowledge of the problems.

The following rough order magnitude costs are provided for preliminary budget figures. The actual cost may vary based on the findings of the various consultants the report recommends using to address specific problem areas and based on the engineering designs utilized to correct the problems. The number in parentheses after the description refers to the number listed in the RECOMMENDATIONS section. It may be practical to include several of these items together under the same contract, such as combining replacing pipe insulation (11) and making piping

repairs (12) with the remediation and restoration (1) work. Items 27 and 28 were not estimated since they are primarily FAA costs and item 27 would have a minimal impact on the sealant replacement cost if work is required. Items 20, 21, and 26 were not estimated as they are routine operational maintenance issues. Items 29 and 30 were not estimated as they are typical operational maintenance costs and the items are not related to the moisture or mold. They were noted since they were found during the inspection.

| | |
|---|------------------|
| Remediation and restoration (1) - includes recommendations (16) and (17) | 312,000 |
| Sealant replacement (2) | 72,000 |
| Relocate/reroute lightning protection (4) | 4,500 |
| Temporary repairs to Cable Access walkway coating (5) | 5,000 |
| Membrane walkway and standing seam roof, long term repair (6) | 90,000 |
| Window consultant inspection (7) and minimal repairs | 6,000 |
| Clean precast concrete panels and apply sealer (8) | 45,000 |
| Junction Level louver repair/replacement (9) | 20,000 |
| HVAC/mechanical review by A/E firm or consultant (10) | 22,000 |
| Replace contaminated/damaged pipe insulation (11) | 30,000 |
| Correct any leaks or problems found during insulation replacement (12) | 5,000 |
| Clean ductwork, coils, HVAC equipment, etc. (13) | 5,700 |
| Replace/repair door weather stripping (14) | 4,100 |
| Repairs at door 707 (15) | 350 |
| Remove vinyl wall coverings and paint, ESU Building (16) - Included in item 1 | |
| Repair/repaint ceilings in J7 and J9 (17) - Included in item 1 | |
| Install insulated doors 107 and 109 in UPS Room 104 (18) | 2000 |
| Replace broken insulated glass unit, ESU Building (19) | 200 |
| Repair/modify duct insulation and vapor barrier (22) | 1000 |
| Clean windows and framing to remove stains (23) | 1100 |
| Replace water stained ceiling tiles (24) | 3200 |
| Replace shut off valves (25) | 150 |
| Clean microwave balconies, prevent bird entry (31) | 2500 |
| TOTAL | \$631,800 |

COST SUMMARY

It is recommended that funding in the amount of \$665,000 be allocated to complete the work identified. The additional funding above the \$631,800 total will support minor changes likely to be required once work has begun. The cost estimates assume that the project will be designed, managed, and procured by FAA personnel except where it is indicated consultants will perform the work. This budget figure includes an allowance of \$3000 for minimal corrective work that may be recommended by the window consultant. No allowance was made to address HVAC system or controls problems, deficiencies, or required upgrades that may be identified during the system review performed per recommendation 10 as the cost could vary significantly based on the actual findings and recommendations. The HVAC system has not been evaluated by a Mechanical Engineer and the corrective work that may be required represents a large unknown at this time. The cost of recurring sealant inspections per recommendation 3 is \$5,000 every two or three years.

BACKGROUND

In October 2007, a request was made by Central Service Area Operations Engineering to visit the facility and investigate water infiltration issues at the facility. Michelle Lott, Program Manager for Occupational Safety and Health Compliance Programs, had also requested Barbara Hebert, Certified Industrial Hygienist, investigate mold problems at the facility and validate reports and assessments of the facility that had been previously prepared. Barbara Hebert and Ed Winkler, Civil Engineer – Operations Engineering, made a joint trip to the facility to assess the mold and moisture related problems, to identify the source of moisture at the problem areas, and to identify corrective action required. After the inspection, the findings were reviewed and budgetary cost figures were prepared. Barbara Hebert is a Texas licensed Mold Assessment Consultant. In order to ensure compliance with Texas regulations, a joint report is being issued and the detailed findings are included in the Mold and Moisture assessment report in the appendix.

Copies of facility as-built drawings were printed and reviewed prior to the site visit to gain familiarity with the site, to identify areas likely to allow water infiltration, and to identify potential problem areas in advance that might require additional on site inspection or review. The facility drawings indicate the building construction was completed in March of 2002. The exterior building envelope consists of precast concrete panels and relies on joint sealant between the various panels to prevent water infiltration. The ATCT design appears to be based on a modification of the Radian standard tower design.

FINDINGS AND CONCLUSIONS

The inspection began with a preliminary walkthrough of the interior of the ATCT, Base Building, and ESU Building as well as the building exteriors in order to gain an understanding of the scope and extent of the problems. After the walkthrough, a detailed investigation began on a room by room basis. The detailed findings list each specific area and actions required and are included in the assessment report in the appendix. This section will identify the major sources of water infiltration found and list any observations made or conclusions drawn related to the cause or corrective work required.

The exterior building inspection showed that the original application of the penetrating stain/sealer on the surface of the precast panels did not provide sufficient or uniform coverage. The color variation and coverage could be seen at many locations. Areas on the east wall of the Base Building appeared to have no coverage of sealant. A distinct line could be seen where it appeared the sealer application simply stopped. The top portion of many panels appeared to lack sealant and the aggregate pattern in the precast panel could be seen (photo 43). A close inspection of the panel surface revealed numerous small holes and voids lacking the sealer coverage and there were numerous areas where debris such as small pieces of wood appeared to be cast into the panel and the thin concrete covering spalled off (photo 42). The poor condition of the sealer contributes to moisture problems in the buildings as moisture is able to migrate through the precast panels into the building. The existing design or construction methods resulted in a poor joint at building corners where the edges of the panels are tapered to a point to locate the sealant joint at the building corner. This edge detail, instead of a chamfered edge, is much more likely to crack or deteriorate and at several locations had done so (photo 51).

Joint sealant at many locations showed signs of failure or poor installation quality (photos 2, 3, 4, 5, 41, 50, 51, and 52). The use of the word "sealant" in this report implies a material used to fill and seal an opening such as caulking. Leaks at sealant joints are a major source of water infiltration. Sealant failure and building joint leaks caused damage throughout the facility such as level 3 (photos 24 and 25) and the Ground level (photos 31 and 32). This is particularly true at the Cable Access level where the sloped precast panels below the cab windows and the exterior walkway form the roof over the building areas below. At these locations, the waterproof integrity of the building envelope relies exclusively on the caulk joints. It appears that some sealant repair/replacement was done around the perimeter of Base Building windows. However, it appears no sealant replacement was done at the top or head of the windows. This may be due to the fact that the existing storm screen housing makes it difficult to reach this joint.

The existing building design and shape or contour of precast panels at the top of openings is poor. The edge of the precast panel is chamfered as it should be for appearance and to minimize cracking, but there is no drip or flashing to slow down water running down the surface of the panels or cause it to drop off and direct it away from the opening and the sealed joint. As built, water is allowed to run down the precast panels and is directed at the sealant joint at the head of the openings (windows, louvers, doors, etc.). Any failure of the sealant joint at the head of openings will likely cause water to enter the building.

As indicated in the paragraph above, the existing ATCT design and construction rely exclusively on joint sealant or coatings to prevent water infiltration, especially at the top of the tower on the

Cable Access and Junction Levels. The appendix contains a sheet titled LEAK PRONE AREAS AT THE CABLE ACCESS AND JUNCTION LEVELS (Attachment 3). The joints or areas prone to leaks are highlighted in green. The design of the exterior walkway appears prone to water leaks, especially where the walkway was cast against the exterior precast panel or parapet wall. The waterproof coating is terminated against the vertical surface of the concrete parapet wall. A gap has formed at this location due to shrinkage of the slab and differential movement of the walkway and precast panel. Using a sealant would help some, but this location provides poor conditions for an effective seal and long sealant life. The coating is in relatively poor condition and items such as the cut off/abandoned pipe provide another possible entry point for water (photo 1). The "waterproof coating" used on the walkway surface appears to have been utilized in an application beyond its intended use since it is typically used as part of a system in combination with a waterproofing membrane. It is not intended to provide a permanent seal against vertical wall surfaces such as the exterior precast or parapet wall (photos 2 and 6). Evidence of leaks at this location can be seen in photo 9. As constructed, it will be difficult to prevent water entry into the building at these locations.

At two locations, the lightning protection was routed through the joint between precast panels at the surface elevation of the walkway (photo 2). This is the worst location to breach the sealant joint and this situation ultimately results in water entering the building. Utilizing sealants only, will require recurring maintenance and continual vigilance to ensure no leaks have developed.

The use of separate precast panels for the sloped panel below the cab windows and the vertical panel on the interior wall of the walkway instead of a single one piece "L" shape panel introduce a caulk joint around the entire perimeter of the Cable Access Level that must be maintained to prevent water entry (photo 5). Failure of this joint and the joints between the sloped panels allowed the vast majority of water infiltration that caused the damage on the Cable Access Level seen in photos 10 - 15.

During construction, it is often difficult to perfectly align the precast concrete panels to provide a uniform joint width or to control the exact width of the joint. As shown in photo 5, the vertical panel at times sits too high and can trap water on the joint sealant. Variation of the joint width can often lead to early sealant failure as the width to depth ration of the installed sealant is critical to its performance. It is not known if the joints and subsequent sealant width were designed to accommodate the anticipated movement, but the joint width and the amount of movement can lead to joint failure if they are not taken into consideration. A more permanent and long term solution than sealants and coatings to waterproof this area is recommended. The use of sealants and coatings will require recurring maintenance and frequent inspection and any leaks will not typically be seen until building materials are damaged and costly repairs become necessary.

Electrical components and controls for HVAC equipment are located on the east wall in room J4 where extensive gypsum board removal must take place during remediation (photo 22). These items will require temporary relocation to perform the work. Additional engineering analysis will be required to identify how to best accomplish this and how to sequence the work. Relocation of the CPME racks in room J3 will be required to perform the remediation and restoration in this area (photo 19). This would best be performed by the FAA in advance of the

contract work. These two locations provide unique complications to the project and resulted in a higher cost estimate to perform the work at these locations.

Several leaks in the Control Cab windows were noted by controllers during the investigation and signs of water leaks were present on the window framing in the cab. Inspection of the cab roof showed all the sealant on the cap flashing at the top of the cab wall system was checked and cracked and showing signs of failure. Leaks at this location could enter the cab wall system or windows. Due to the geometry and construction of the tower, it was not possible to perform an up close inspection of the cab glass. Since there are active leaks here, as well as the Junction Level window (also inaccessible) and several Base Building windows, a consultant should be utilized to inspect the existing installations, including pressure plates and internal weeps below the covers to determine any problems or deficiencies with the installation and to determine any corrective work required.

Inspection of the two microwave balconies found excessive amounts of nesting materials and bird droppings. These items can be food sources for mold and can cause other health problems. Additional measures such as bird exclusion netting are required to prevent bird entry.

Extensive evidence of water damage was found on the Cable Access Level (photos 9 through 16) and Junction level (photos 17 and 18). Multiple ceiling tiles had been removed from the Junction Level Ready Room ceiling apparently due to water stains and damage and several trash cans were positioned throughout the room to collect leaks, making the room virtually unusable. Controllers indicated that there had been leaks in this room for at least two years. The primary source of water infiltration is the failed sealant in building joints identified above and the design and construction of the exterior walkway.

During the walkthrough of the space on the Cable Access Level below the walkway, the flashlight being used was turned off to inspect the sealant behind the structural steel at building corners. At four of the eight corners, daylight could be seen along the vertical joint where the precast panels meet. Wind noises were also observed in this space providing another indicator of the failed joint sealant. The failed sealant allows moisture into the building both in the form of water during rains and as vapor in the outside air that enters the tower through the failed sealant joints. This additional moisture likely migrates to other areas of the tower and causes higher humidity levels as a result.

The outer wall of the Cable Access Corridor coincides with the bottom edge of the sloped precast panels below the cab windows. The water damage and mold growth on this wall were extensive. All of the gypsum board on this wall around the full perimeter of the ATCT will have to be replaced to a height of 4'. At that time, a visual inspection will need to be made to determine if any mold continues up the back side of the gypsum board, especially at the column enclosures as this point is located below the joints between the sloped precast panels. At one location in the Cable Access Corridor, two water streaks were visible running down the sloped gypsum board ceiling and outer perimeter wall. The source of this water appears to be from a leak near the cab windows.

The inspection of the facility showed mold on many surfaces such as walls, doors, walls in stair vestibules (photo 30), ductwork (photo 36), diffusers (photo 44), pipe insulation, the surface of

air handling units and fan coil units. Water leaks at building joints contribute to this problem but it also appears that environmental conditions in the tower and the design and operation of the HVAC system contribute to the problem. In room J3, the display on Computer Room Unit, CRU-10, showed a relative humidity of 65%. It is not known if the existing HVAC system and controls can remove sufficient quantities of moisture from the air during cooling to maintain the humidity level in the facility low enough to avoid contributing to mold growth on surfaces in the facility. Additional cooling and reheat may be required to satisfy building occupants and reach this point. This would increase operating costs.

Reports were made of condensation on ductwork causing water stained ceiling tiles. Condensation was also identified as a source of water in the All Points Environmental report. No condensation was observed on ductwork or HVAC equipment during this inspection. Mold was found on the exterior of some ductwork at seams and appeared to be the result of condensation caused by air leakage (photo 45). Additional evaluation and observation will be required to identify and address condensation problems with ductwork or HVAC equipment. It should be verified that the buildings are maintained under positive pressure in relation to the exterior under all operating conditions. At times, opening the door between the Junction Level Mechanical Room and Microwave Balcony #1 caused a noticeable amount of air to be pulled into the Mechanical Room.

Heavy mold growth was found on chilled water piping insulation in many areas of the facility (photos 17, 26, and 48). The majority of the pipe insulation consisted of a canvas or mesh-like jacket that does not appear to provide an adequate vapor barrier jacket as installed. In general, the surface of the pipe insulation appeared too porous to provide a tight vapor barrier. Breaches in the vapor barrier jacket or a poor vapor barrier will result in condensation on the piping or fittings. The heaviest water damage and mold growth were found on horizontal pipe sections where moisture would tend to accumulate and keep the insulation wet for longer periods of time. Approximately 60% of the chilled water piping insulation showed signs of mold or water damage. A small amount of hot or heating water pipe insulation had mold. In stair vestibule J2, the mold on the pipe insulation appeared to be caused by building leaks wetting the ceiling and the pipe insulation. Mold on the heating pipe insulation near room 104 in the ESU Building appears to be caused by condensation from cold air leaks from the UPS room contacting the warm pipe or warmer more humid air in room 101. All of the insulation will need to be replaced if it does not provide an adequate vapor barrier.

The majority of exterior steel doors had mold on the surface that appears to be caused by condensation due to air infiltration and the temperature differences between the surface, inside air, and outside air. This air infiltration can also raise the humidity level in the facility. This was also found to be a problem at door 603 in room J4 which had a broken lockset and did not latch properly. Double doors with the removable center post appeared to be in the worst condition since they lacked weather stripping at the center post. The existing weather stripping provided minimal surface area contact and in many cases did not make contact with the door (photos 34, 35, and 37).

In many locations with water damaged ceiling tiles, it was difficult to determine the exact source of the water. The causes may vary among building leaks, roof leaks, pipe leaks, condensation on piping or ductwork, etc. These areas will require additional observation. It is recommended to

replace all the ceiling tiles with water stains and investigate the source as soon as any stains or wet spots appear on the ceiling tile.

Several Air Traffic rooms in the base building were locked by the time the inspection proceeded to those locations. Facility personnel were not able to open the doors. The conditions in these rooms could not be evaluated. The analysis by All Points Environmental should be used to evaluate work required in these rooms. This includes rooms 104 and 107.

Items requiring immediate action were brought to the attention of local personnel. These included the following: repair of the faucet sprayer leak in room 122, repair of corridor drinking fountain drain leak, and repair of broken lockset on door 603.

RECOMMENDATIONS

The recommendations apply to all buildings (ATCT, Base Building, and ESU Building) unless noted otherwise. The order does not represent any prioritization of the recommendations.

1. Remove all contaminated building materials and replace as indicated in the attached Mold and Moisture Assessment Report. Replace and restore all building finishes. Utilize mold resistant materials such as paperless gypsum board. Clean contaminated surfaces and make repairs indicated in the report. All signs of water damage must be repaired or cleaned in order to determine if the corrective work was successful in preventing water infiltration. The more significant repairs are listed as line items in the recommendations.
2. Replace all exterior sealants. This includes all joints between precast panels, joints around the perimeter of building openings (doors, windows, louvers, etc.), flashing (cap flashing, splices, laps, reglets, etc.), and building penetrations (conduits, pipes, junction boxes, receptacles, etc.). Some Base Building window perimeters appeared to be resealed except for the head or top of the opening apparently due to the storm screen housing blocking access. Sealing the top of the window perimeters is critical to preventing water infiltration. The head of all openings lack an integral drip or other feature to cause the water to run off and prevent it from running down the face of the wall and following the wall surface around the panel edge at the opening and running to the caulk joint. The repairs should address ways to compensate for this deficiency. The lightning protection cables must be routed overhead and out of the joint between precast panels prior to performing the sealant replacement.
3. Implement a recurring sealant inspection and maintenance program to physically inspect all joints every two or three years. This will require the use of a bucket truck or crane to access and inspect all areas of the tower.
4. Relocate/reroute existing lightning protection at the Cable Access Level exterior walkway overhead so that it does not penetrate the parapet wall or existing joint sealant nor create a trip hazard on the walkway. This must be accomplished before walkway repairs or sealant replacement.
5. Repair/reseal the concrete surface of the exterior walkway at the Cable Access Level, especially the joint between the walkway and exterior precast/parapet wall. Grind or cut off the abandoned pipe sufficiently below the surface of the walkway and patch. Water test all drains in the walkway for leaks into the building area below, especially the east drain where a bucket was found placed under the drain and piping with damaged insulation was observed. Obtaining a long term repair will be difficult due to the existing design. This recommendation only provides a quick short term fix until more extensive work can be done. A more permanent and long term fix is recommended as indicated below.

6. The existing building design relies exclusively on sealant or a waterproof coating on surfaces that form roofs over areas of the ATCT such as the joints between the sloped panels below the Control Cab Windows, joints in the parapet wall at the perimeter of the walkway, or the waterproof coating over the concrete walkway at the Cable Access Level. Recurring maintenance, inspection, and repair will be necessary to prevent water damage and mold growth similar to what has occurred. Recommend designing and installing a waterproofing system that will be more reliable and less recurring maintenance. This could include the installation of a waterproof membrane roofing system to eliminate reliance on caulk joints. The recommendation includes covering all sloped precast panels from the cab windows, the interior walkway wall, the walkway, the exterior walkway/parapet wall, and the top of the parapet wall with a membrane system that would include metal cap flashing on the top of the parapet wall. This would require removal of the existing parapet wall and increasing the height of the wall to maintain the required OSHA handrail height of 42". It would also require replacing the existing drains with a drain that can be used on a membrane roof. The evaluation of the roof repairs should address the lack of overflow scuppers or drains that would prevent overloading the roof if the drain line became blocked. The overflow drains typically accept flow at a point two inches above the roof surface. It is further recommended to use a standing seam metal roofing system over the sloped precast panels and interior walkway wall to maintain an acceptable finished appearance for the facility and to reduce maintenance and reliability of the roof over this difficult to access area.
7. Utilize/hire a window consultant to inspect all existing window systems and installations to identify any existing defects or problems with the existing installation and to make recommendations for repairs and needed corrective actions. Include the skylight in the inspection. Consider utilizing a water test to identify all active leaks. Make repairs recommended by the consultant.
8. Clean, prepare, and seal all precast concrete panels. The existing sealer application coverage is not uniform, does not appear to be holding up to the environmental exposure, and is not effective in preventing the migration of moisture into the building. Repair all damaged, broken, cracked, or spalled sections or edges of panels prior to the sealer application.
9. Inspect the Junction Level Mechanical louver. Due to the location and height, the louver could not be closely inspected as is necessary. The drawings identify it as a storm proof louver, yet water infiltration appears to be a problem. The current louver is oversized and the majority is blanked off on the interior and not used. Some of the water infiltration may be due to leaks at the perimeter of the building opening. Consider the use of a wind driven storm proof louver. It may be more economical to fill in the existing opening and utilize the correct size new louvers versus installing a full size louver to fit the opening and blanking off the unused portions.

10. Conduct a complete analysis of the existing HVAC system to verify that the original design and existing equipment and controls are capable of maintaining the desired conditions within the building including keeping the humidity at acceptable levels that do not support mold growth. This includes an engineering analysis of the design, sequence of operations, set points, and current operating parameters. The analysis should include testing and balancing of all systems and should verify the extent of duct air leakage. The investigation should also focus on reported problems of condensation from ductwork or HVAC equipment causing water damage to building finishes such as ceiling tiles and verify the adequacy of existing duct insulation (internal and external). Verify that the buildings are maintained under positive pressure with respect to the outside under all operating conditions. Existing temperature and humidity levels should be monitored, recorded, and analyzed as part of this effort. It appears that the existing HVAC system is not removing enough moisture from the air during cooling and this contributes to mold growth throughout the facility. Verify that humidity levels are maintained no higher than 50% and ideally lower. The investigation also needs to address the extensive problems with condensation and mold on chilled water piping and the adequacy or effectiveness of the existing pipe insulation installation and the vapor barrier jacket.
11. Replace contaminated or water damaged pipe insulation.
12. Correct any leaks or piping deficiencies found during the insulation replacement.
13. Hire a contractor to perform internal cleaning of all ductwork, coils, HVAC equipment etc. HEPA vacuum all supply air diffusers, return air grilles, exhaust grilles, etc. to remove dust and clean as recommended to remove mold.
14. Replace, improve, and add additional seals and weather stripping at all exterior doors to prevent air infiltration, increased humidity levels in the facility, condensation, and mold growth on adjacent surfaces. Add weather stripping where none exists such as at the removable center post on double doors. Consider weather stripping with additional contact surface area to provide a better seal.
15. Correct water infiltration at door 707 on the Cable Access Level exterior walkway. Replace or reseal threshold in sealant and ensure slope to exterior. Seal between threshold and door frame. Verify adequacy of perimeter seals/weather stripping.
16. Remove vinyl wall coverings from exterior walls in rooms 107 and 108 in the ESU Building and perform any remediation required and paint exterior walls similar to the work performed in the Base Building.
17. Repair and repaint water damaged gypsum board ceilings in rooms J7 and J9.
18. Replace uninsulated steel doors 107 and 109 in UPS Room 104 with insulated steel doors to prevent condensation caused by the large temperature differences between the UPS Room and adjacent rooms.
19. Replace one broken insulated glass unit in the window of room 105 of the ESU building.

20. Replace or repair the leaking spray nozzle on the faucet in the Base Building Break Room (room 122).
21. Repair existing lockset on door 603 in Mechanical room J4. The door does not latch and seal which allows air infiltration from the outside (Microwave Balcony #1).
22. Repair external duct insulation damaged from opening door 603 at Microwave Balcony #1. Modify insulation installation, duct, or door to prevent recurring damage to the insulation and vapor barrier jacket.
23. Clean all windows and window framing after repairs and resealing to help verify the adequacy of the corrective work so that any stains, streaks or residue found will indicate a remaining leak or a new leak that must be addressed.
24. Replace water stained ceiling tiles throughout the facility and conduct routine inspections to investigate any water stains as they recur. This needs to be done on an ongoing basis to identify problems such as condensation on piping or ductwork that may only appear under certain conditions or at a particular time of the year. This provides the opportunity to investigate any new stain as it occurs and improves the likelihood of finding the cause. Particular attention should be given during heavy or driving rains to locate the source of any roof leaks.
25. Replace shut off valves under the sink in Ready Room J5 to ensure reliable leak free operation.
26. Repair a drip in the drain pipe connection apparently caused by an impact to the drinking fountain across from room 128.
27. Investigate the insulated metal panel (IMP) installation at the penthouse for a correct installation. The void between the bottom of the panels and the base flashing was filled with sealant. This space is typically left open to allow water in the vertical panel seams to weep out of the system. Verify the current IMP system is installed correctly and does not trap water.
28. Recommend that the FAA temporarily relocate CPME 1 and CPME 2 to provide adequate work space for the remediation contractor to perform the required work in room J3.
29. Replace lamps or repair light fixtures in the following areas that did not have adequate lighting during the inspection: RA4, L22, L23, and L33.
30. Repair oil leaks at the Junction Level and Cable Access Level floor hatches.
31. Clean microwave balconies. Remove bird droppings and nesting materials. Install bird exclusion netting or other measures to prevent bird entry.



Photo 1: Cable Access Level Walkway.

This photo shows the concrete walkway and the interior precast concrete wall below the Control Cab at the Cable Access Level. The walkway also serves as a roof over the Cable Access level and the Junction Level below. Facility drawings indicate that the walkway consists of a “waterproof sealer on top of concrete slab”. A pipe or conduit cut off near the surface can be seen. The “waterproof sealer” has spalled off at this location and can be seen flaking off the concrete deck near the left of the photo. The walkway has an integral concrete curb (shown on the right side) along the interior perimeter of the walkway, which helps prevent water entry into the facility. Ideally the top of the curb should be higher above the surface of the walkway to ensure water cannot enter the building in the event of extremely heavy rains that overwhelm the drains or if water builds up due to a plugged drain line. The walkway lacks overflow drains or scuppers typically required/installed on roofs to prevent the accumulation of excessive amounts of water on the roof.



Photo 2: Cable Access Level Walkway.

This photo shows the concrete walkway and the exterior perimeter precast concrete wall at the Cable Access Level. The precast concrete wall serves as a parapet wall or guardrail for the walkway and continues below the walkway forming the exterior building wall for the Cable Access Level and Junction Level. The waterproof integrity of the caulk joint at the corner where the precast panels meet is critical as any failure along the interior side of the panels at the walkway, across the top edge of the panels, or along the exterior side of the panels down to the Junction Level, will allow water penetration into the building. The existing caulk joints are in poor condition. Routing the lightning protection conductor through the caulk joint at the level of the walkway surface is a poor practice as it creates a condition extremely likely to allow water entry into the building. The rusting fastener in the surface of the walkway also provides a point for water entry. A small crack can be seen where the waterproofed concrete walkway slab terminates against the precast panel. Differential movement of the walkway slab and precast wall panels, combined with a waterproof coating that is not flexible enough, will cause this joint to open. This joint is highly susceptible to water infiltration.

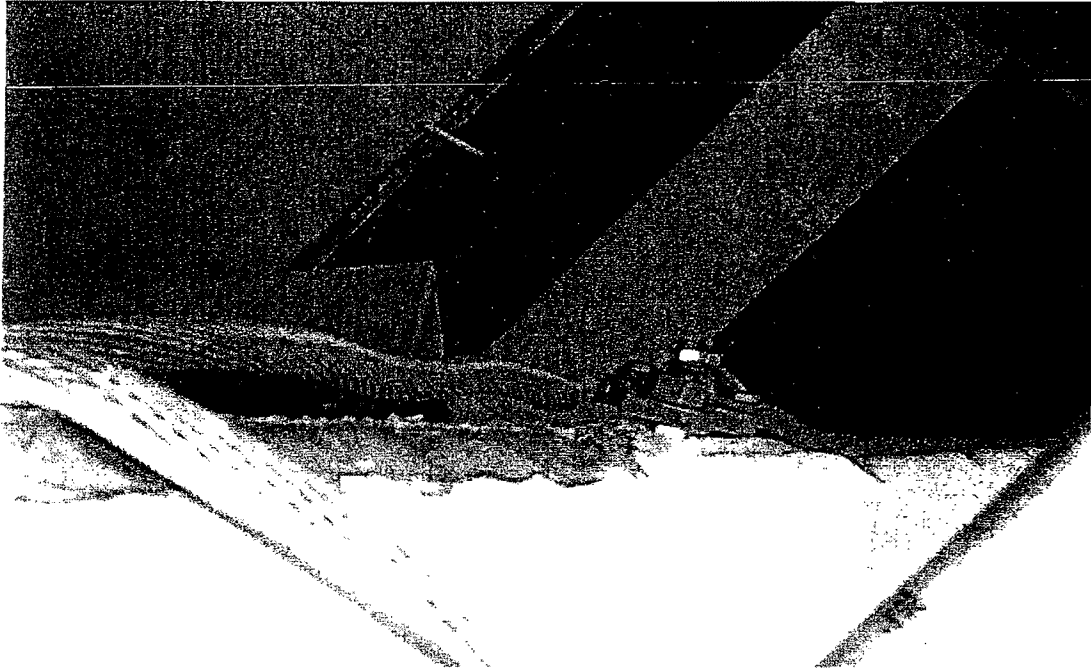

Photo 3: Cable Access Level Walkway.

This photo shows the lightning protection conductor seen in photo 2 penetrating through the exterior side of the caulk joint between precast panels along the exterior perimeter of the walkway. The caulk joint is in poor condition and shows signs of deterioration.

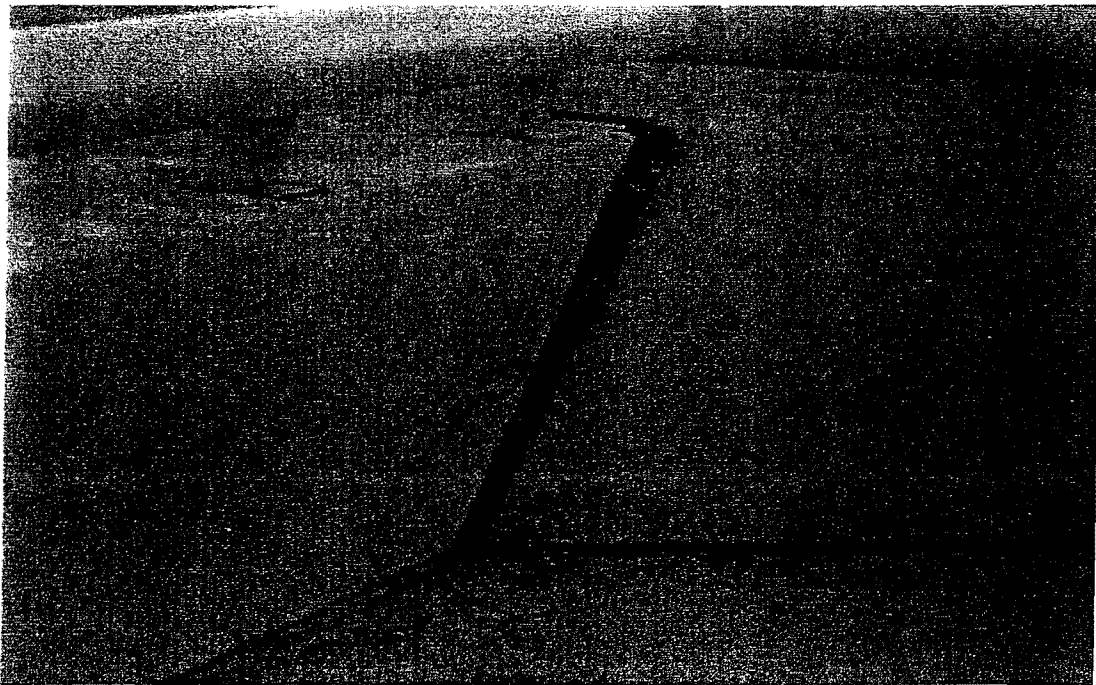

Photo 4: Cable Access Level Walkway.

This photo shows one of the caulk joints where precast panels meet at the exterior corners of the concrete walkway at the Cable Access Level. The caulk joint is in poor condition. Any failure of this joint will allow water entry into the building.

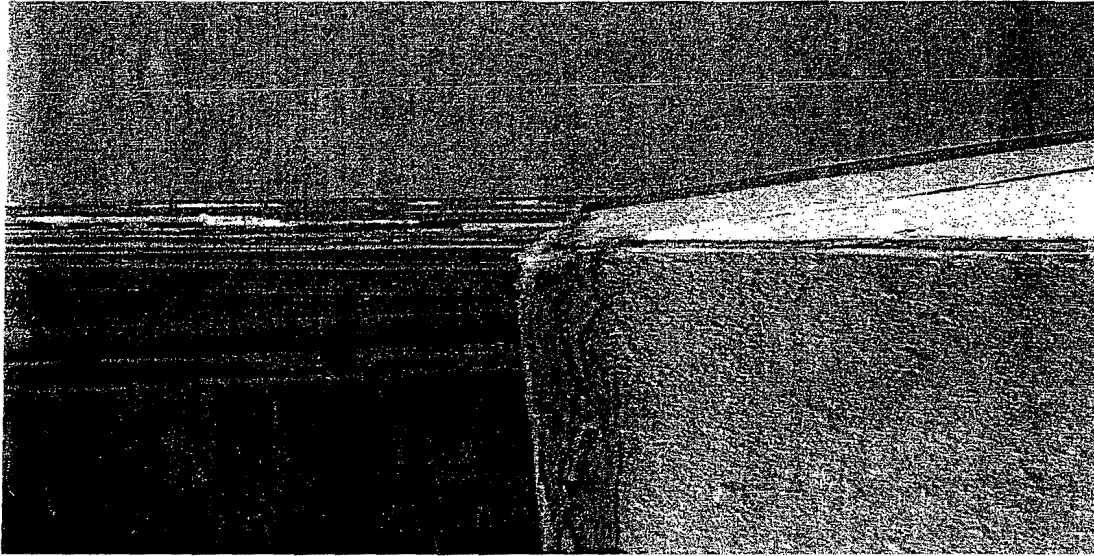

Photo 5: Cable Access Level Walkway.

This photo shows multiple caulk joints in the precast panels forming the interior perimeter wall of the walkway that forms the exterior wall of the Cable Access Level and the sloped precast panels forming the roof over the Cable Access Level. The joints are in poor condition and some attempt was made to provide a temporary fix for water leaks. Variation in the joint width makes it more difficult to obtain a good seal as variations in the width and thickness of the sealant can lead to premature failure of the joint. The use of separate precast panels for the sloped and vertical sections leads to a caulk joint around the perimeter of the building. The contaminated wall in the Cable Access Level (see photos 9 through 15) is located directly behind the vertical precast panels. The worst damage is located below the corners.

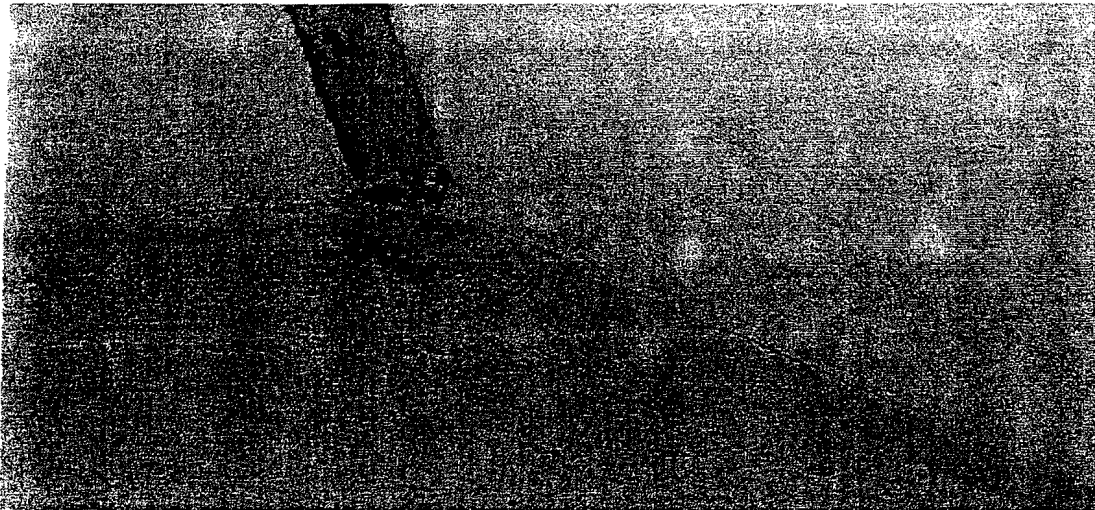

Photo 6: Cable Access Level Walkway.

This photo shows a portion of a deteriorated caulk joint between precast panels on the exterior perimeter of the walkway. The separation and crack between the waterproof coating on the concrete walkway deck and the precast wall panel can be seen to the right of the photo. Both items contribute to water infiltration into the facility.

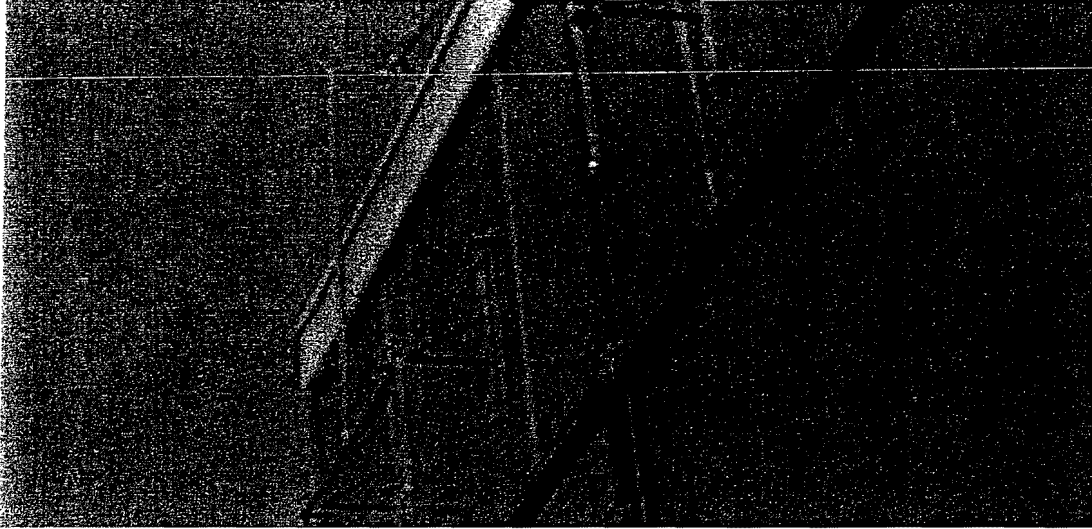

Photo 7: Cable Access Level Walkway.

This photo shows the insulated metal panels and framing system above the Control Cab glass. Some sealant can be seen on framing members. Streaks on the interior of portions of the glazing system in the Control Cab show signs of past water leaks. Several recurring leaks were reported by controllers during the inspection of the Control Cab. It is not possible to access, adequately view, or inspect the window system from the Control Cab roof or the Cable Access Level Walkway.

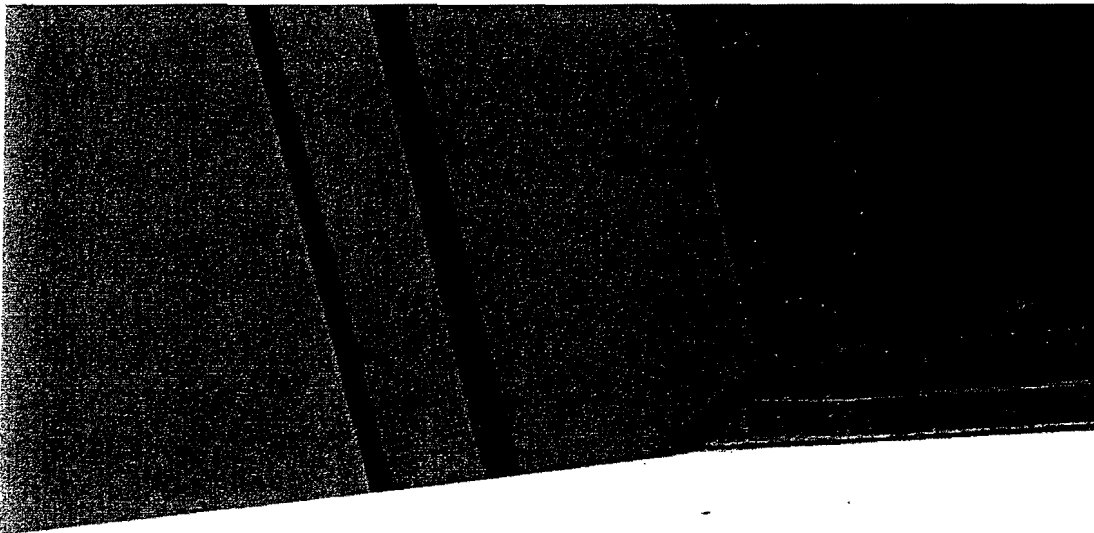

Photo 8: Cable Access Level Walkway.

This photo shows the sill condition at one corner of the Control Cab. It is not possible to access, adequately view, or inspect the window system from the Control Cab roof or the Cable Access Level Walkway. Evidence of or reports of leaks were only observed or reported at the tops of the windows. There is a possibility that some of the water damage at the Cable Access Level could originate from the window system. All of the interior surfaces below the windows were covered with gypsum board so it was not possible to see any evidence of water stains or streaks on the concealed precast.

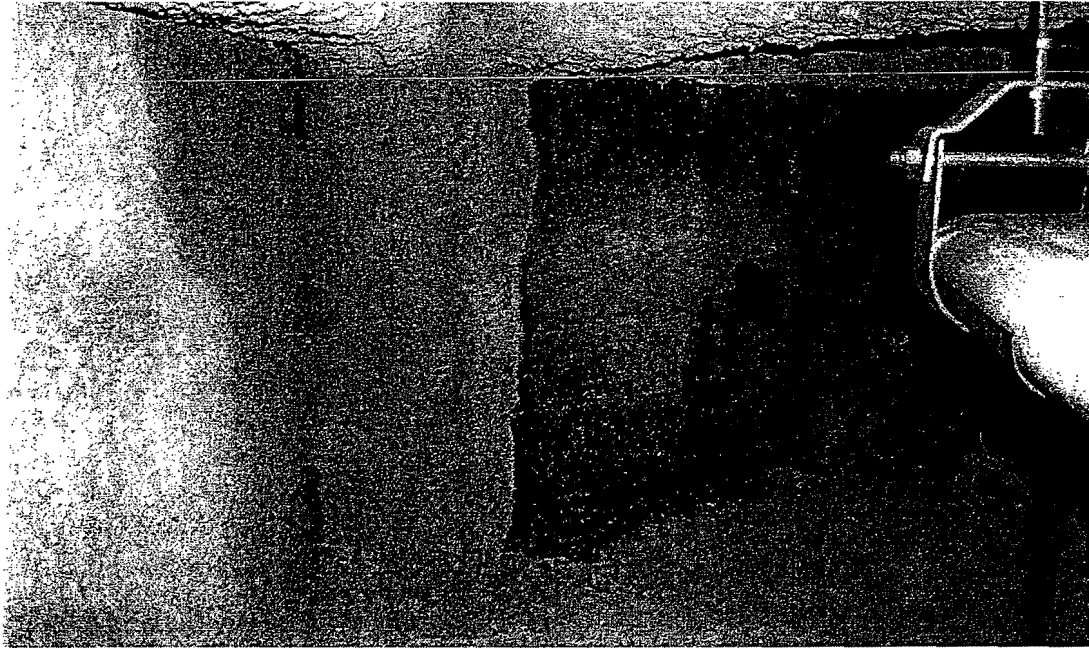

Photo 9: Cable Access Level, Unfinished Space Beneath Walkway.

This photo was provided by Jesse Lopez (I90 District). The extent of wet concrete and fireproofing overspray on the exterior concrete wall shows evidence of leaks at the intersection of the walkway surface and precast parapet wall.



Photo 10: Unfinished Side of Wall, Room CA2.

Insulation was removed to expose this area to view. This photo shows water damage and mold on the back side of the gypsum board wall separating the Cable Access Corridor (Room CA2) from the unfinished/unconditioned space beneath the walkway. The white residue and rusting of the metal studs and runner show that there has been significant water infiltration on a recurring basis. This wall is located directly behind the vertical precast panel on the interior perimeter of the exterior walkway shown in photo 5.

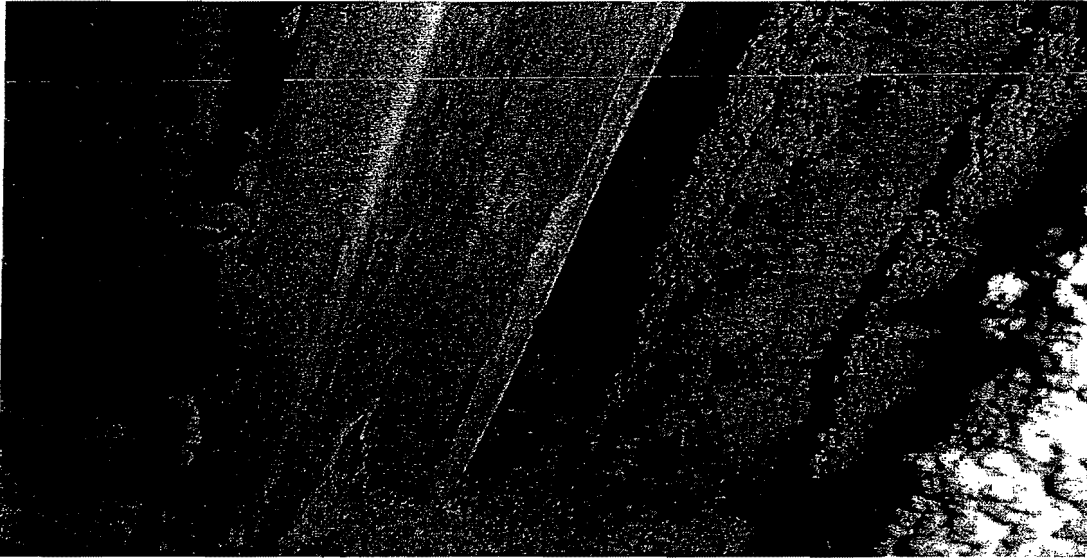

Photo 11: Unfinished Side of Wall, Room CA2.

This photo shows water damage and mold on the back side of the gypsum board forming the column enclosures in the wall separating CA2 from the area beneath the exterior walkway. The worst damage was typically near the columns, which are located at the corners of the building and are directly below the caulk joint between the sloped precast panels forming the roof of the Cable Access Level.

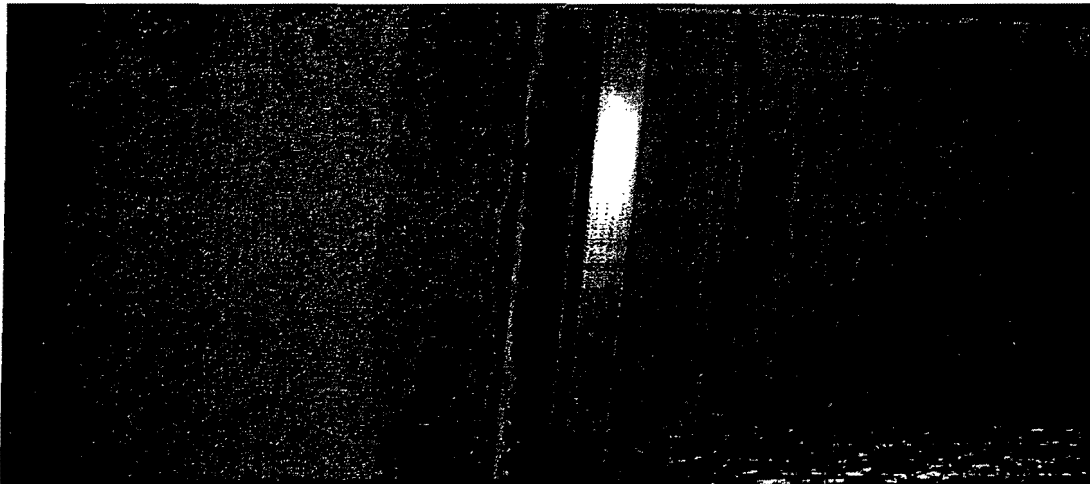

Photo 12: Unfinished Side of Wall, Room CA2.

Mold and water stains are visible on the back side of the gypsum board wall separating CA2 from the unfinished/unconditioned space below the exterior walkway. It is likely that the fireproofing has also gotten wet due to the evidence of visible rusting.

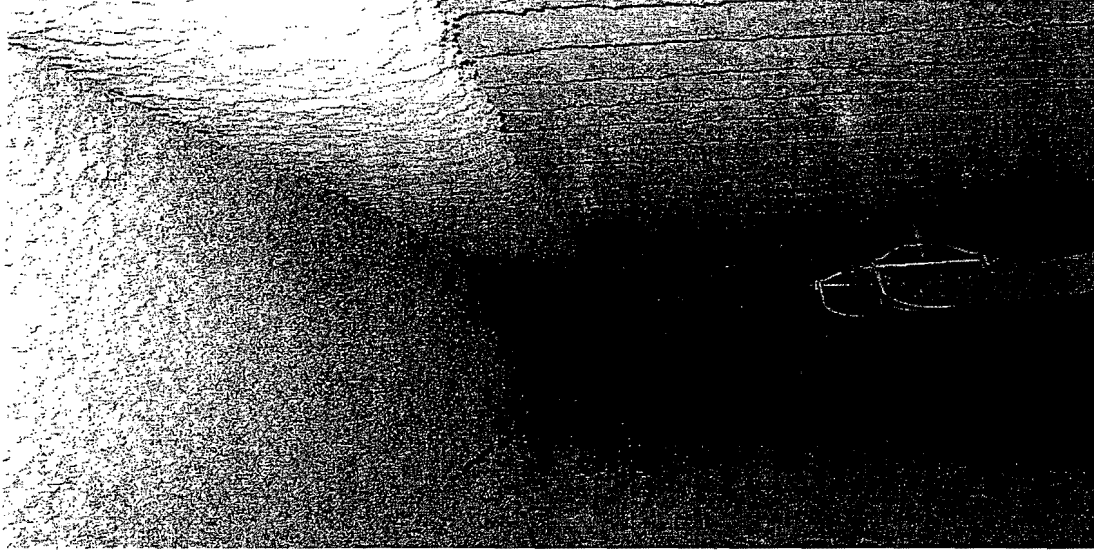

Photo 13: Unfinished Side of Wall, Room CA2.

This photo was taken in the unfinished/unconditioned space around the exterior perimeter of the Cable Access Level. It shows the underside of the exterior concrete walkway and the interior face of the precast panels that form the exterior wall of the Cable Access Level and Junction Level. The edge of the walkway is supported by the structural steel adjacent to the precast wall. With the flashlight turned off and no source of light in this space, significant amounts of daylight could be seen behind the structural steel in four of the eight corners on the east side of the Cable Access Level. Wind noises were also very noticeable in this area. These findings show evidence of significant failure of the sealant joints at the corners of the precast panels at the flared out section of the tower at the Cable Access Level and Junction Level.

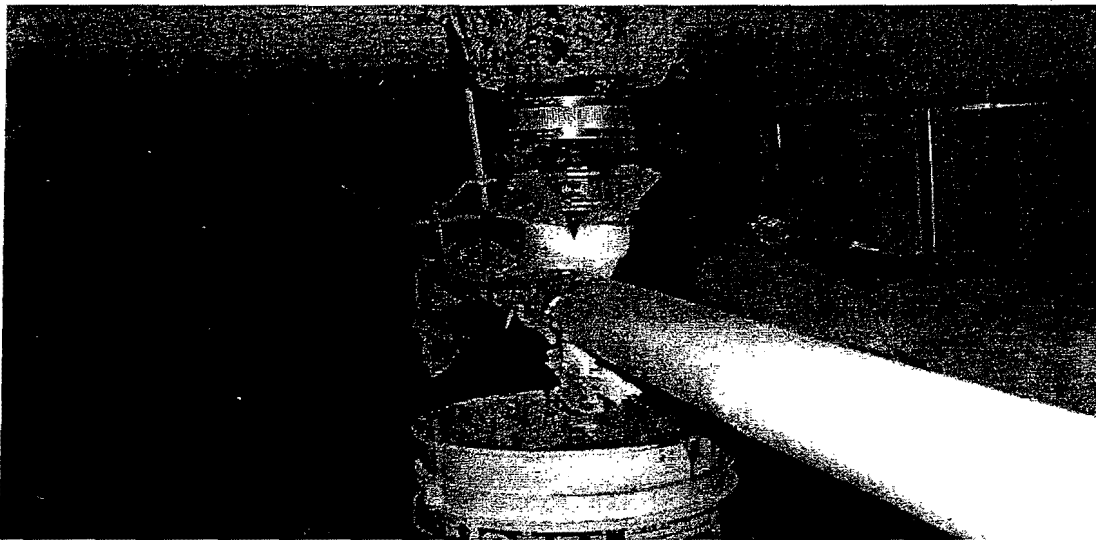

Photo 14: Unfinished Side of Wall, Room CA2.

A five gallon bucket was found under the drain on the east side of the exterior walkway at the Cable Access Level. Pipe insulation had been removed apparently to inspect the piping or connection. No evidence of an active leak was found.

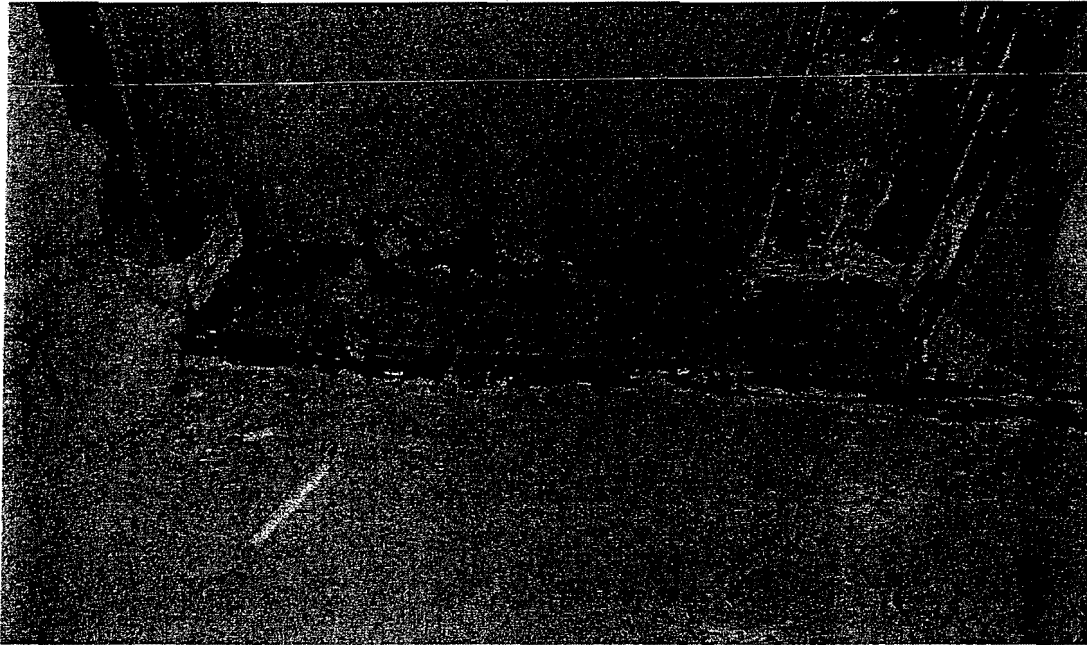

Photo 15: Unfinished Side of Wall, Room CA2.

This section of heavily rusted metal runner at the base of the wall on the south side of the Cable Access Level provides evidence of significant amounts of recurring water infiltration over an extended period of time.

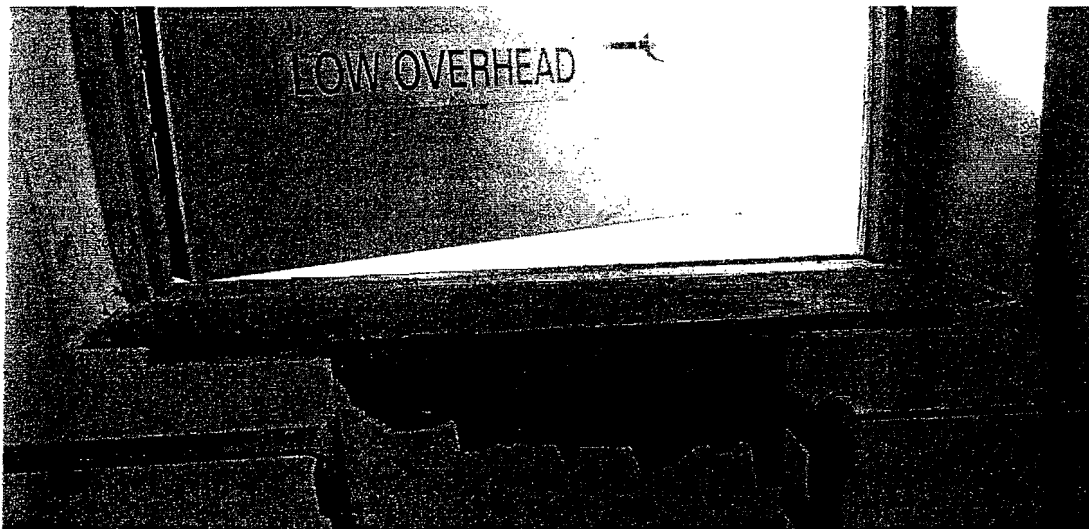

Photo 16: Room CA3, walkway door threshold.

Evidence of water infiltration can be seen by the rust on the bottom of the door frame and by the damaged gypsum board on both sides of door 707 between CA3 and the exterior walkway.



Photo 17: Room J2, West Wall.

The west wall and ceiling of the Stair Vestibule showed extensive signs of yellowing and mold contamination from recurring water exposure. Mold was found on both the chilled and heating water pipe insulation. Mold was not typically found on hot water piping in other areas of the facility. It is likely that the pipe insulation was wet due to building leaks. The room likely has high humidity as mold was also found on the fan coil unit, door 604, and both sides of door 605.

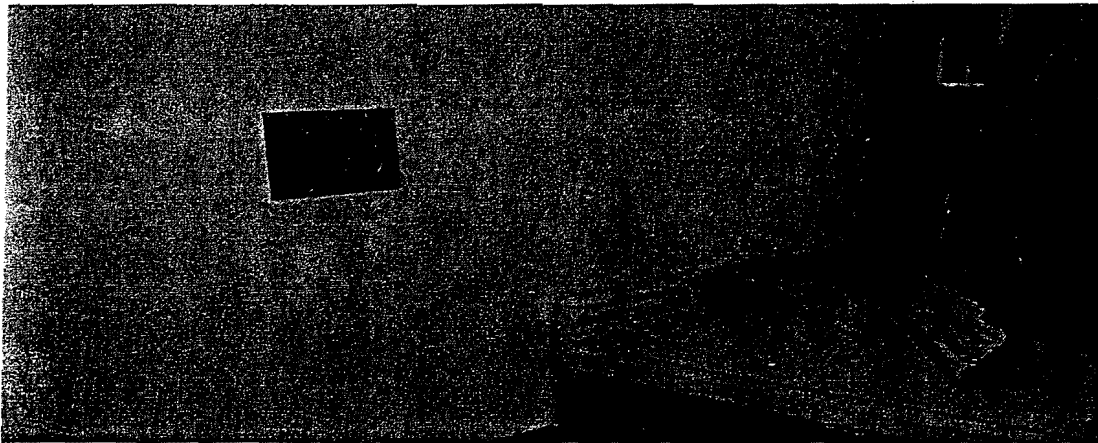

Photo 18: Room J3, East Wall.

Extensive water damage, yellow stains, and mold were found on the east wall. This area was not identified as a problem in prior assessments conducted at the facility. The majority of the gypsum board will have to be replaced. The stains, deposits left around the receptacles, and the streaking below the device plate show the magnitude of the problem. The source of water is likely a combination of leaks from the Cable Access Level Exterior walkway and the failure of the horizontal joint sealant between precast panels on the exterior wall behind. A section of wall base was pulled loose to confirm the extent of the problem.

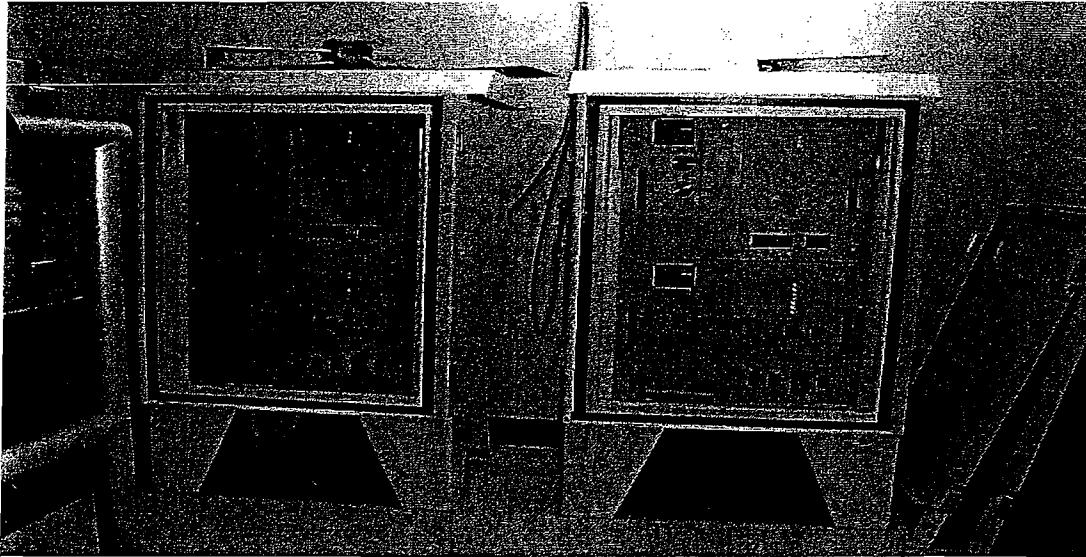

Photo 19: Room J3, East Wall Receiver and Transmitter Racks.

As indicated in photo 18, the wall behind the CPME racks and below the raised floor is water damaged or contaminated other than near the top of the wall. It will be necessary to relocate the CPME racks and remove the raised floor along the wall to perform the remediation and restoration work. The raised floor and the CPME equipment racks will complicate the remediation and add to the cost.

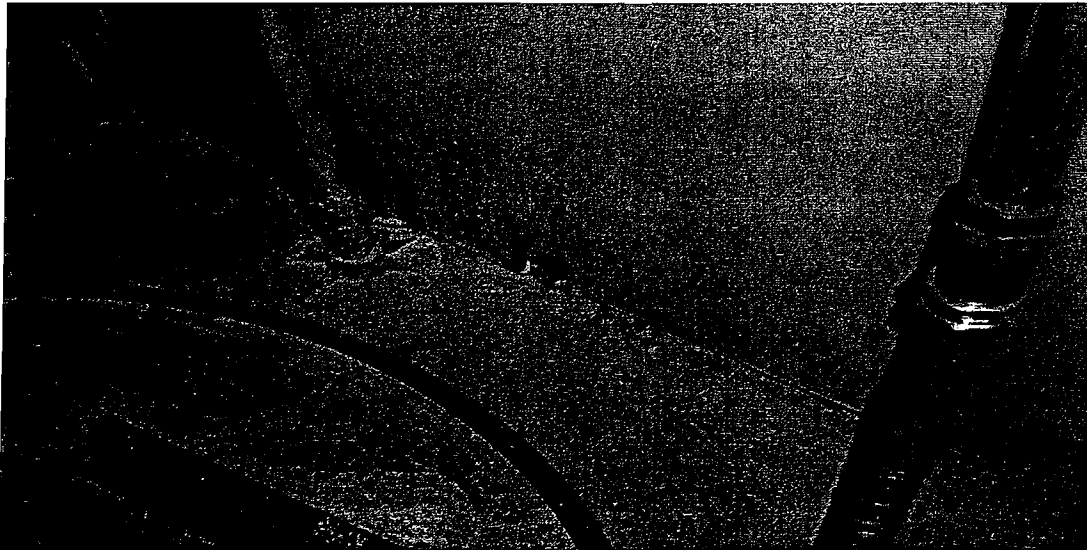

Photo 20: Room J3, North Wall under Raised Floor.

The gypsum board below the raised floor was unfinished and unpainted leaving the paper facing exposed. It was spotted throughout the area under the raised floor as shown in the photos. A small section of the paper was pulled off the face of the gypsum board at the edge of the panel to the right of the raised floor pedestal to provide a bulk sample for laboratory analysis. The sample confirmed the presence of mold. Cleaning may address the problem.

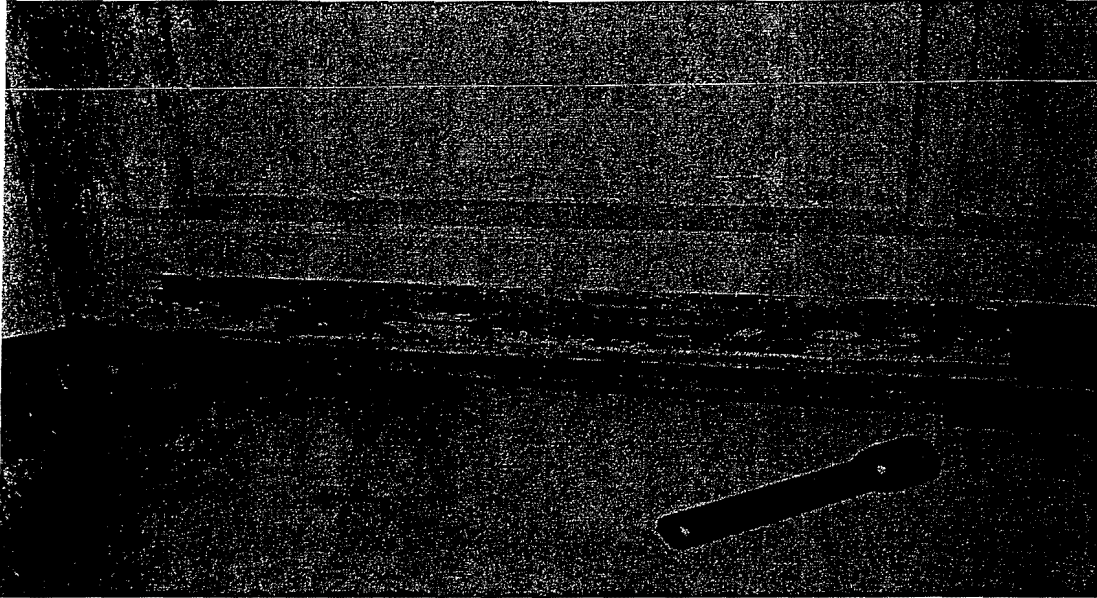

Photo 21: Room J4, South Wall under Outside Louver Panels.

Yellow water stains and mold were visible on the surface of the gypsum board below the opening in the precast wall for the louvers. Removal of a section of wall base showed additional contamination. The majority of the louvers were blanked off and not used. The drawings indicate storm proof louvers, but it was not possible to get close enough to the louvers to inspect them due to their height. The louvers and perimeter sealant likely allow water infiltration.



Photo 22: Room J4, East Wall.

Mold and discoloration were visible on this wall and door and frame 603 to Microwave Balcony 1. The latch on this door was inoperable and was stuck inside the door causing the door to not seal tightly. This allows excessive outside air entry into the building. The HVAC controls and electrical equipment on the wall will increase the complexity and cost of the remediation and restoration in this area.

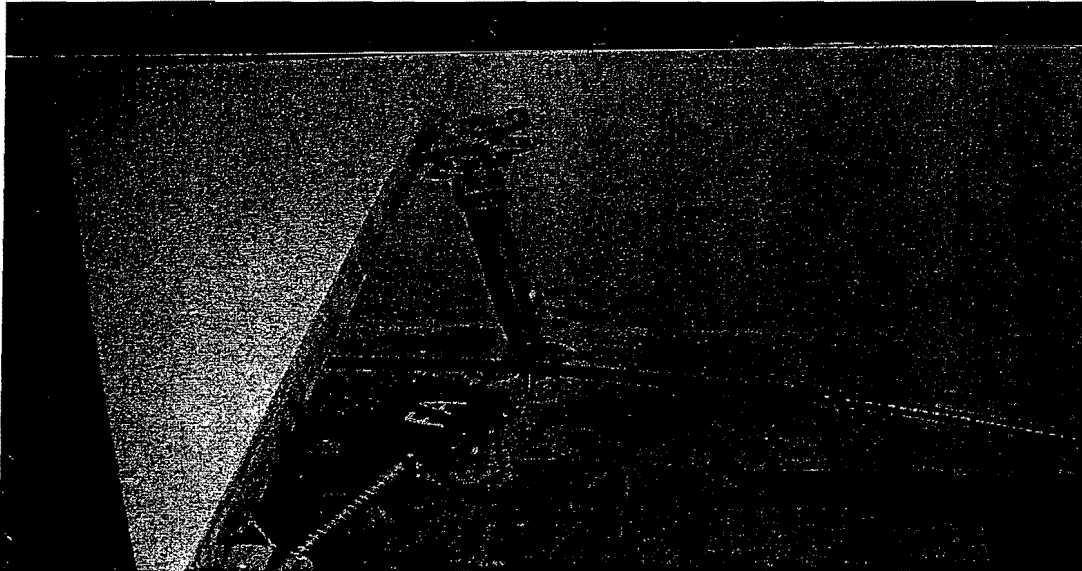

Photo 23: Room L31, West Wall under Raised Floor.

The gypsum board below the raised floor was unfinished and unpainted leaving the paper facing exposed. It was spotted throughout the majority of the area under the raised floor as shown in the photos. A small section of the paper was pulled off the face of the gypsum board at the edge of the panel to the right of the raised floor pedestal to provide a bulk sample for laboratory analysis. The sample confirmed the presence of mold. Cleaning may address the problem.

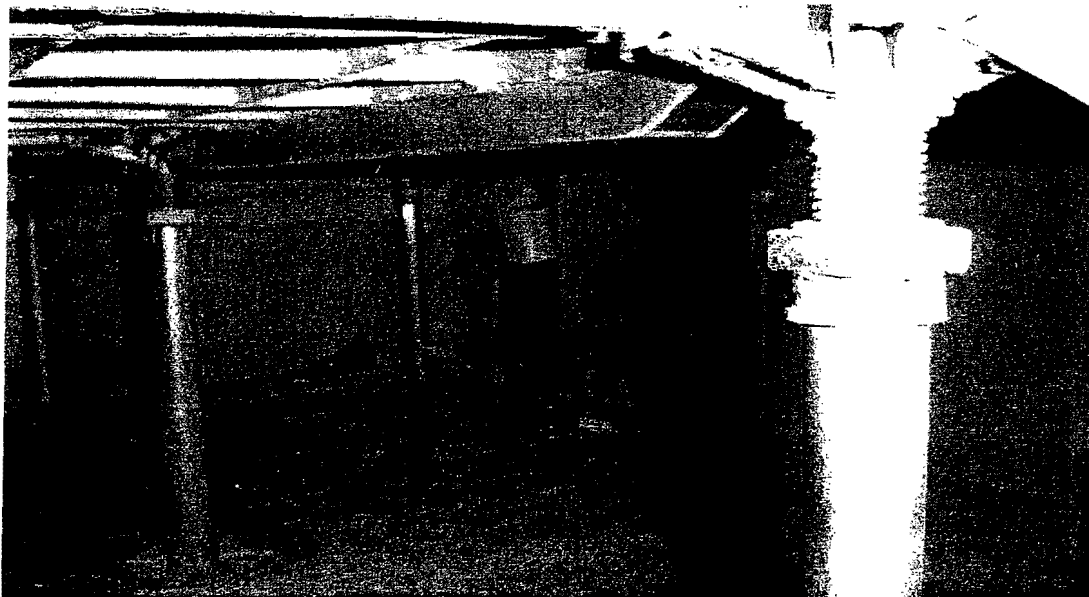

Photo 24: Room L33, North Wall under Raised Floor.

Mold can be seen at the bottom of the gypsum board at the concrete slab under the raised floor in Stair Vestibule L33. This is an outside wall. The source of water is likely building leaks due to failed caulk joints between precast panels.

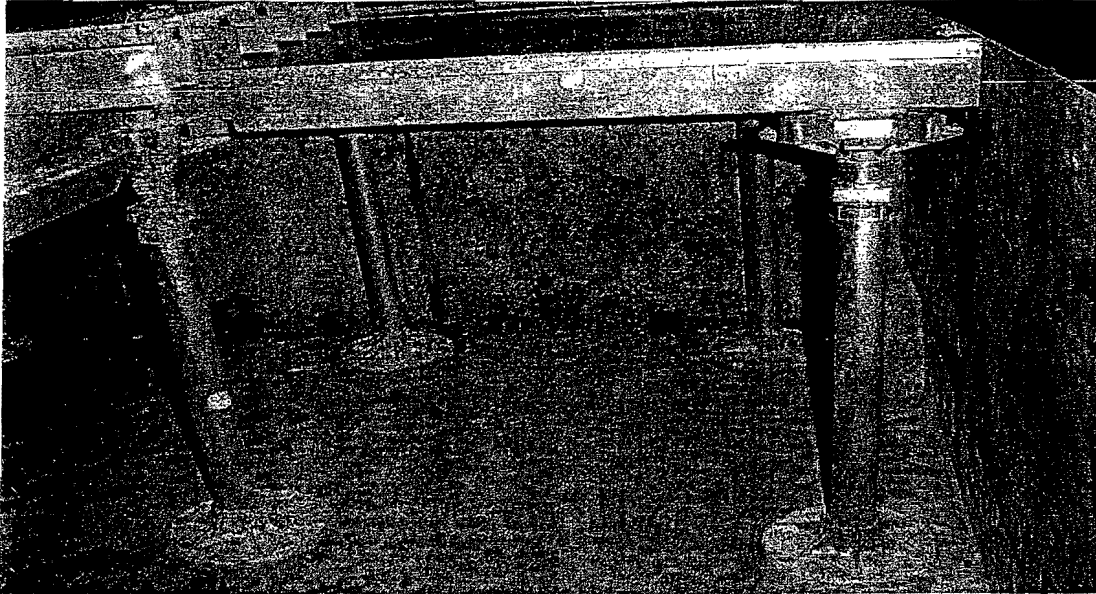

Photo 25: Room L33, South Wall under Raised Floor.

Heavy amounts of mold were found on the south wall and portions of the east wall under the raised floor in Stair Vestibule L33. The mold could be caused by the accumulation of water under the raised floor from building leaks or from high humidity levels in the facility.

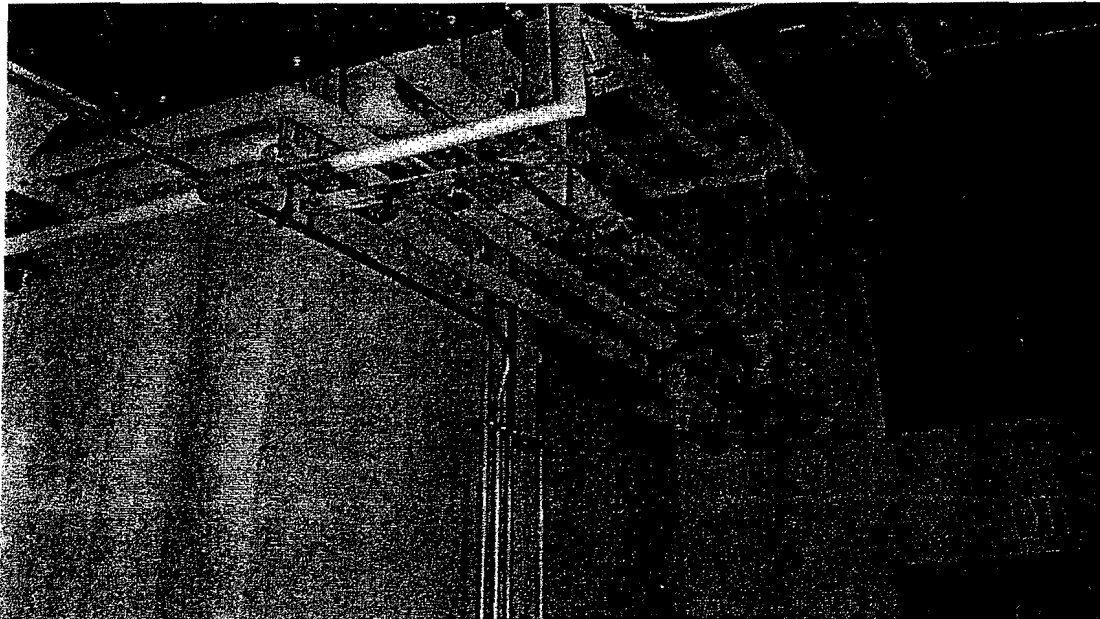

Photo 26: Room RA1, Moldy Chilled Water Piping.

Mold growth and discoloration was common on the majority of chilled water piping in the facility. The problem was more pronounced on horizontal piping insulated with the canvas type vapor barrier jacket as opposed to piping with the all-service vapor retarder jacket (ASJ). This may be due to the fact that the field applied vapor barrier is not as tight as that on the piping with the ASJ and the moisture appears more likely to accumulate in the horizontal sections of piping.

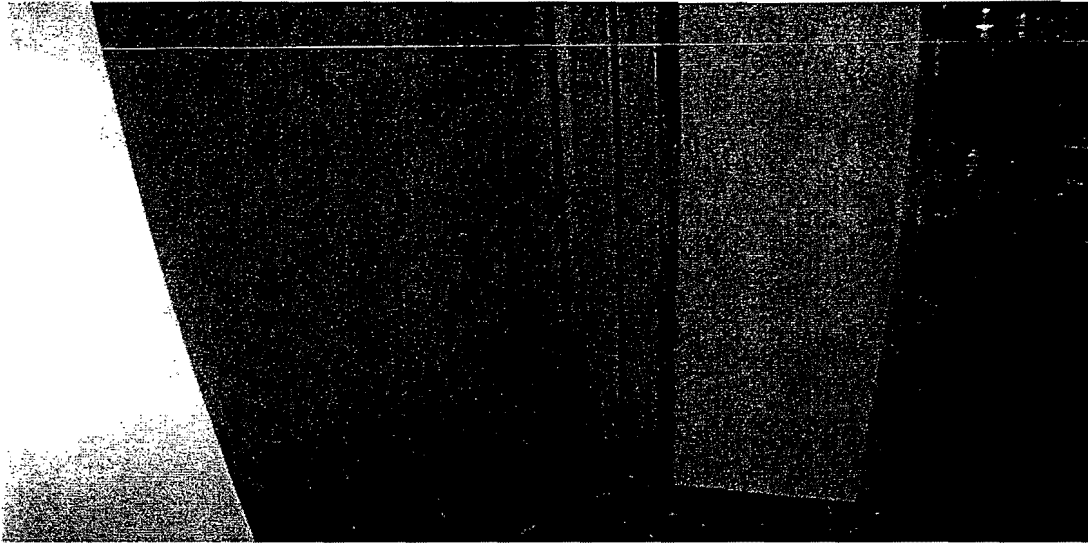

Photo 27: Room RA1, South Door to Roof.

Water damage and staining are visible on the gypsum board return adjacent to door 204 to the Base Building Roof. The source of water is likely building joint leaks due to sealant failure. Condensation on the steel door frame may have also contributed to the problem.

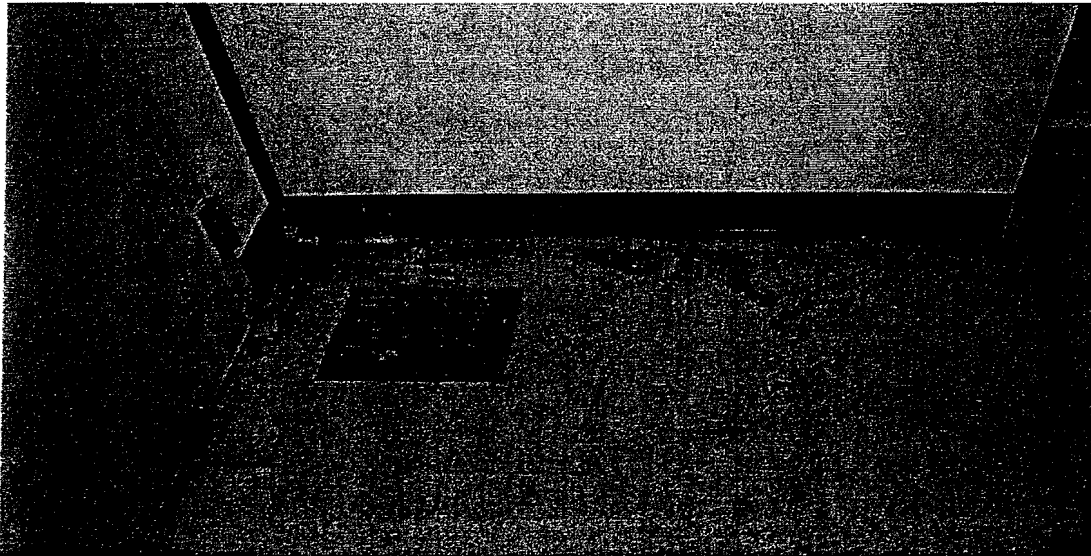

Photo 28: Room RA1, Southeast Corner of Room.

Staining of the wall, vinyl base, and floor tile was visible from splashing or the backup of water discharged from the drain line at this floor drain. The bottom edge of the base was pried up without removal to expose the bottom of the gypsum board. It was held up above the finished floor and did not appear to absorb or wick up any water from the drain. The walls and floors should be cleaned, the drain routinely inspected to ensure it is operational and not draining slow, and the drain line and/or floor drain modified to prevent splashing and wetting the wall or allowing water to accumulate and migrate to other areas such as under adjacent door 202 and into the cable chase.

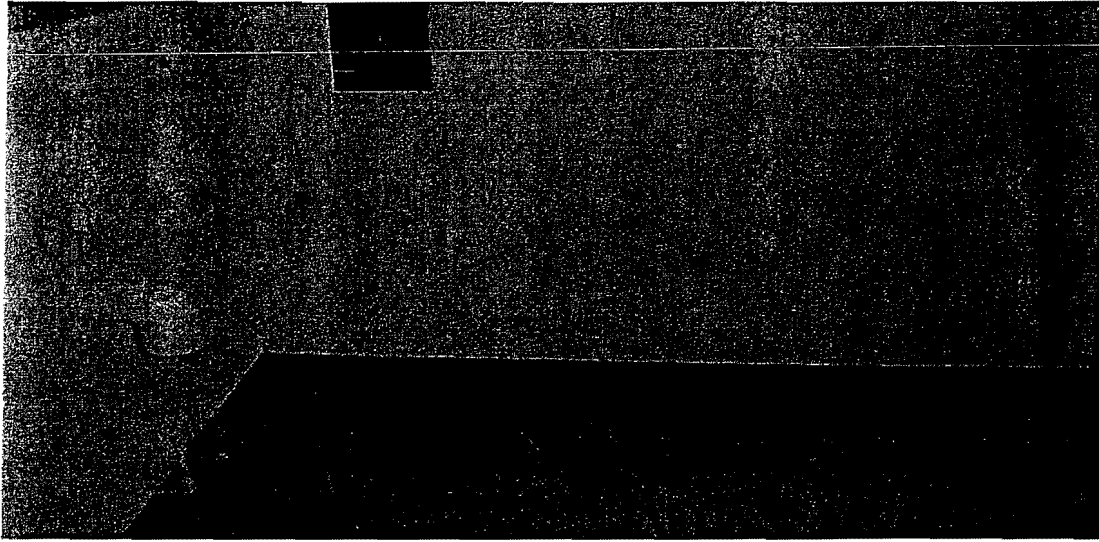

Photo 29: Room RA1, West Wall.

This photo shows discoloration and mold growth on the lower portion of the wall between room RA1 and the stairs.

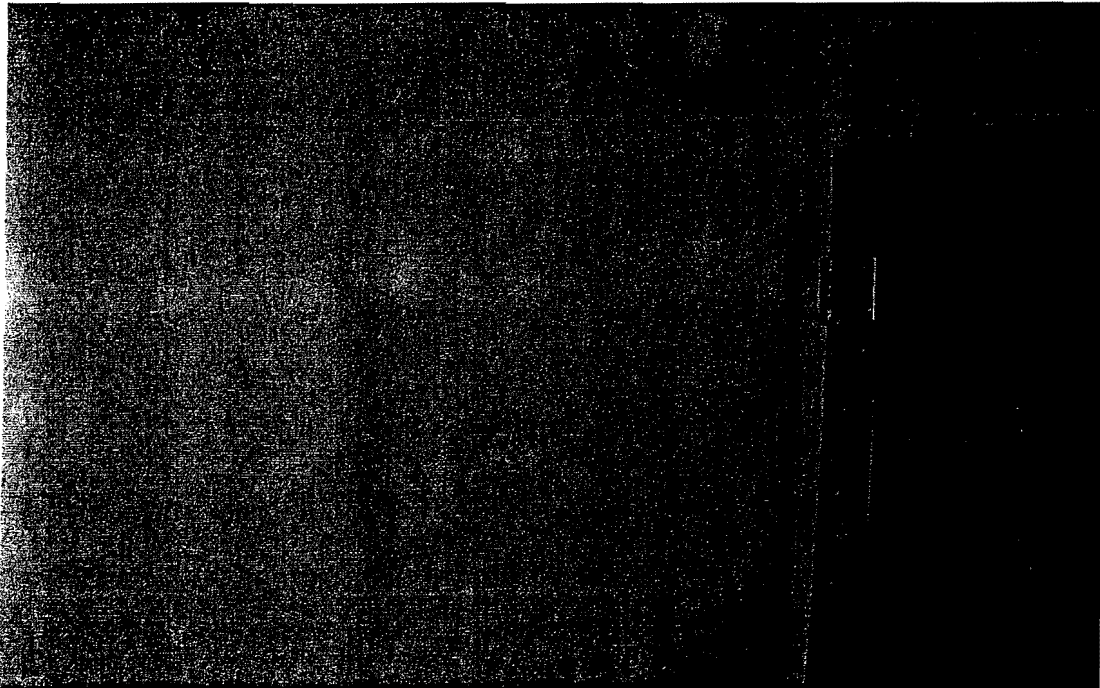

Photo 30: Room RA4, Moldy Stripe on Southeast Side of Door.

Mold was found at the intersection of the two walls in the southeast corner of Stair Vestibule RA4 adjacent to door 205 to room RA1.

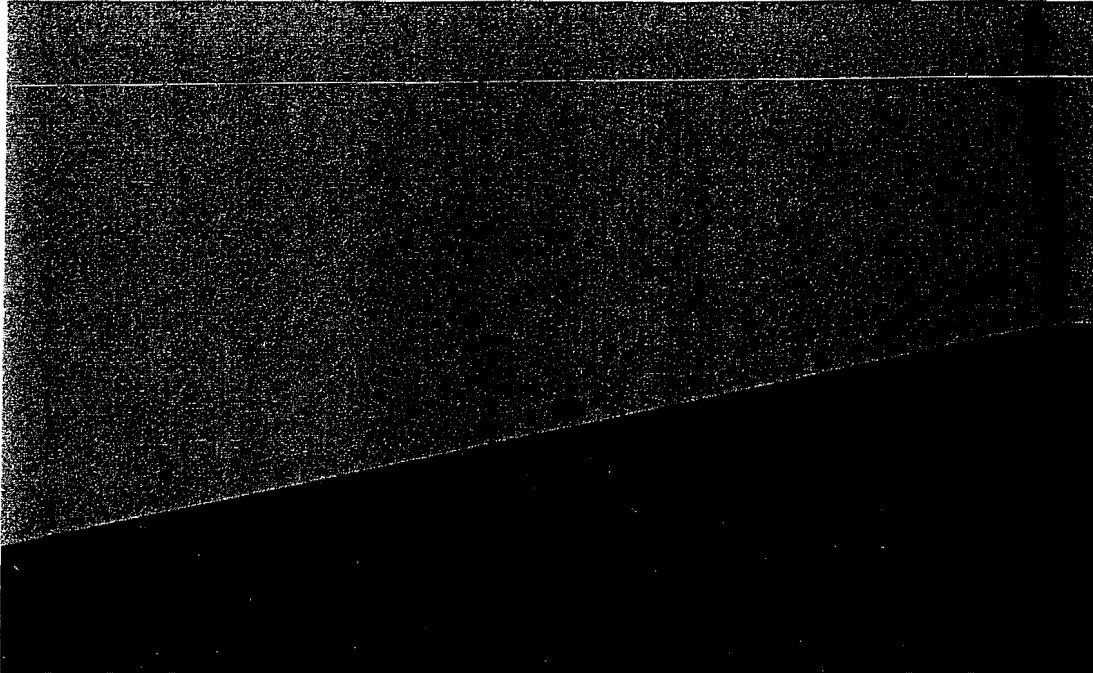

Photo 31: Ground Floor Stairs, Northwest Wall.

Mold and discoloration were found along the bottom of the gypsum board wall. The source of water appears to be leaks through failed caulk joints between precast panels. This area was not documented in previous assessments of the facility.

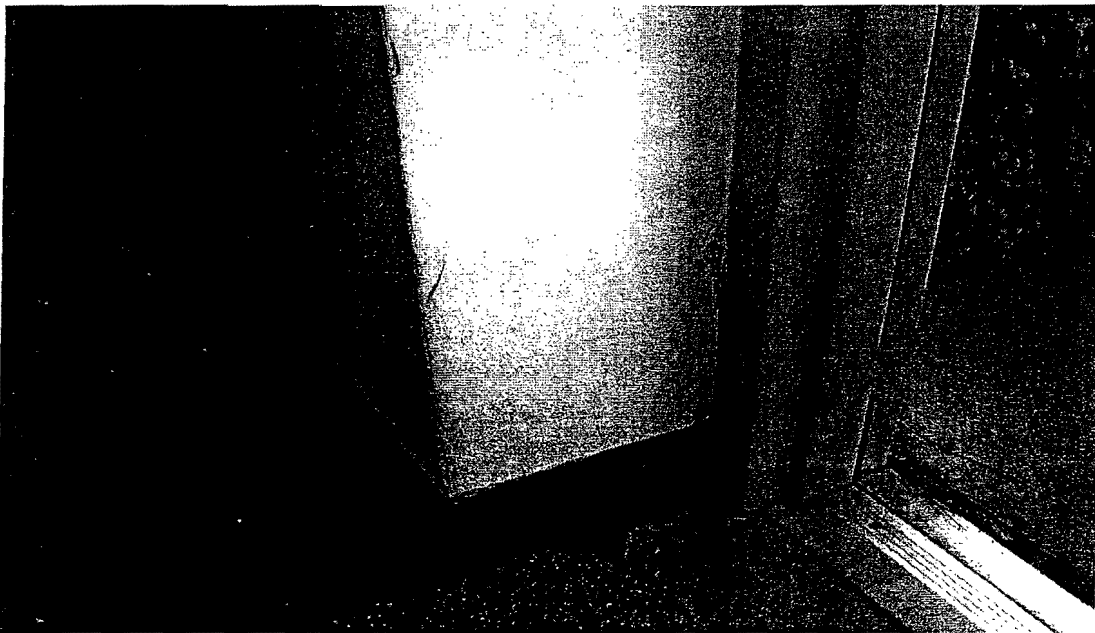

Photo 32: Ground Floor Stairs, West Side of Door.

Mold was found on the gypsum board adjacent to door 105 to the exterior. In addition to building joint leaks, condensation and air infiltration may also be an issue. A section of damaged/missing weather stripping can be seen on the door frame.

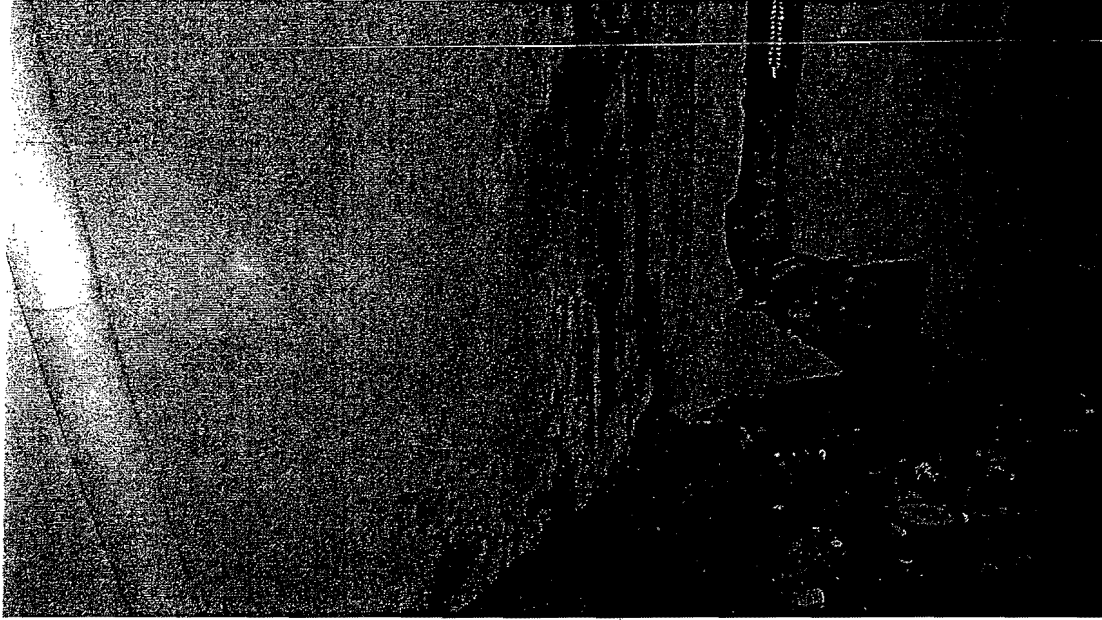

Photo 33: Room G3, East and Northeast Walls.

Extensive water damage and mold were visible on the gypsum board in the Pump Room. A piping problem was responsible for the damage.



Photo 34: Base Building Room 131, South Door.

Mold was found on the interior surface of door 131. The problem was more pronounced where a good seal is not provided allowing inside and outside air to mix and condense on the surface of the door. The location shown allows wiring for the magnetic door lock to pass between the door and frame and allows more air infiltration than other areas of the door/frame interface. This is typical of the majority of the doors in the facility.

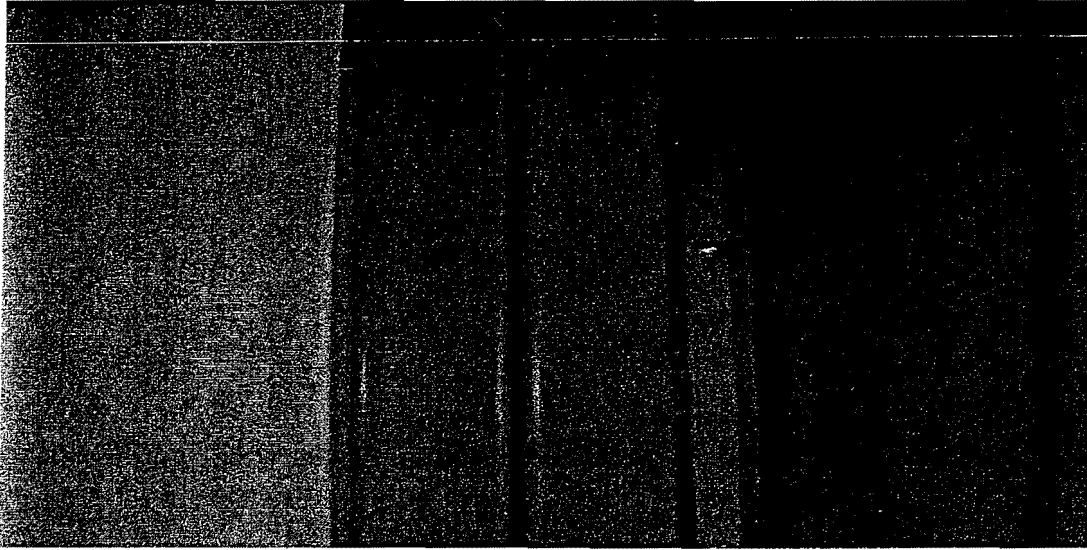

Photo 35: Base Building Room 132, East Door.

The weather stripping shown on the door frame of door 123 provides minimal surface area contact with the face of the door and at many locations there are gaps between the weather stripping and the door. The mold was typical along the edges of the door where it meets the weather stripping but was heavier where the weather stripping and door did not make good contact.

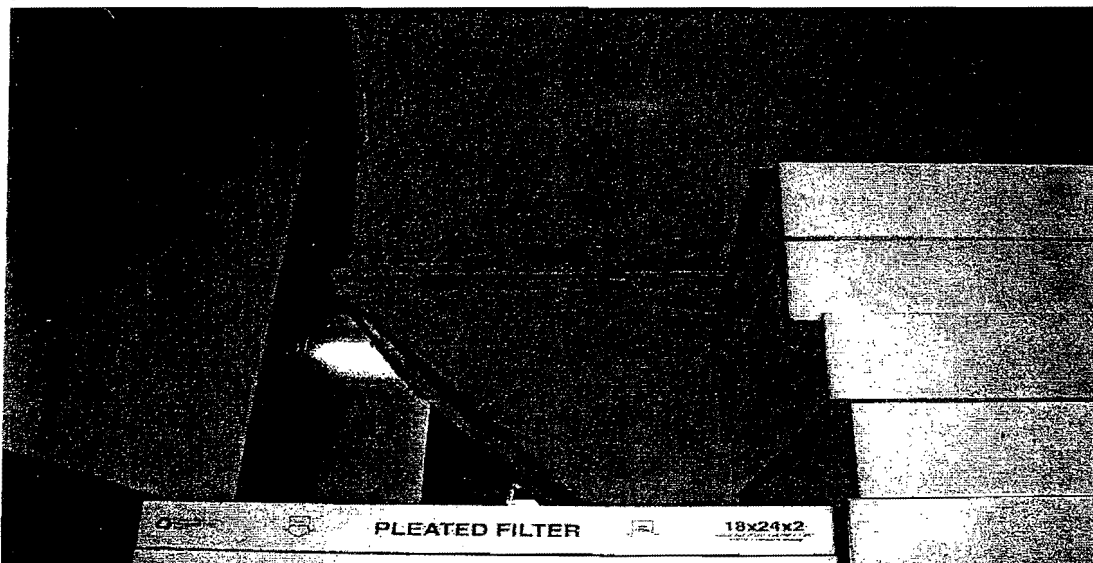

Photo 36: Room 142, Mold on HVAC Ductwork.

Mold was visible on the surface of the duct. The air filters appear to have minimal water staining on the edges. It is recommended that the air filters be kept in the box in a dry area away from any active mold growth.

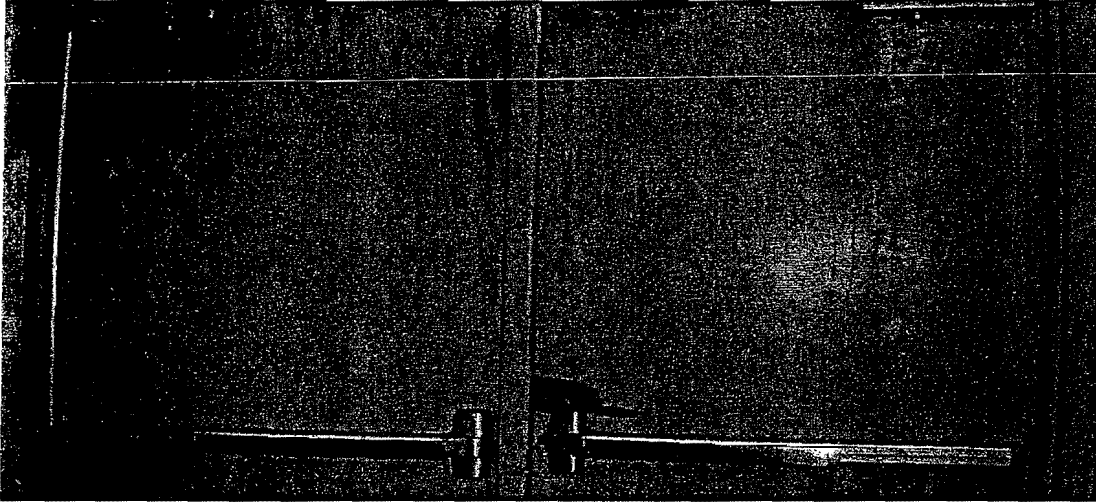

Photo 37: Room 142, South Outside Door.

Streaking from condensation or water infiltration was visible on door 132. The removable center post or the doors do not have weather stripping to prevent air infiltration or mixing of the inside and outside air, which are at significantly different temperatures and humidity levels. The perimeter weather stripping provides minimal surface area of contact to seal against the door and often has gaps allowing air infiltration.

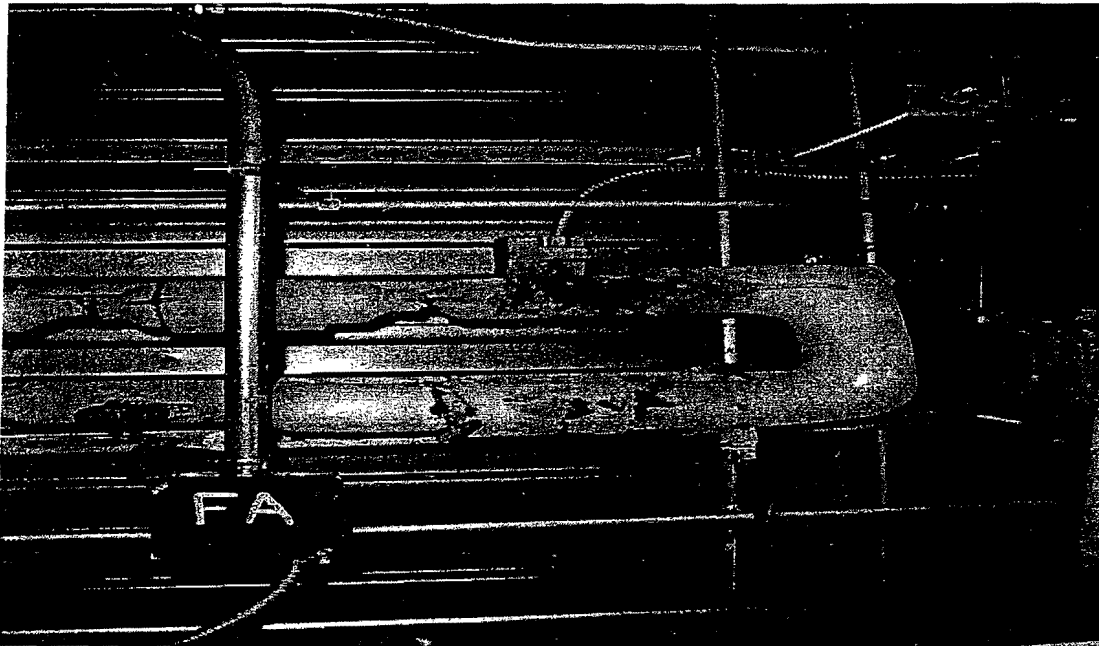

Photo 38: Room 145, Leaking Pipe above Ceiling.

The damaged pipe insulation provides evidence of leaks in the hot water (heating) supply and return piping. It was above the ceiling where a new stain was found on the ceiling tile shown in photo 39.

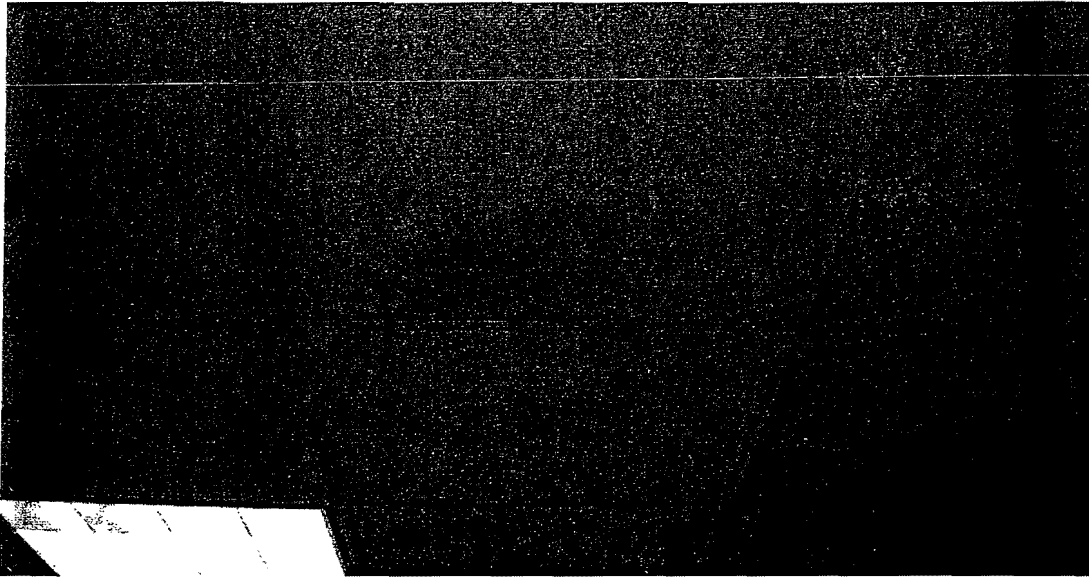

Photo 39: Room 145, Stained Ceiling Tile below Pipe in Photo 37.

The ceiling tile shown was wet during the inspection. This area was inspected since the previous assessment showed a small water stain on a ceiling tile in this office. The cause is seen in photo 38. Action had been taken to isolate the piping until repairs could be made.

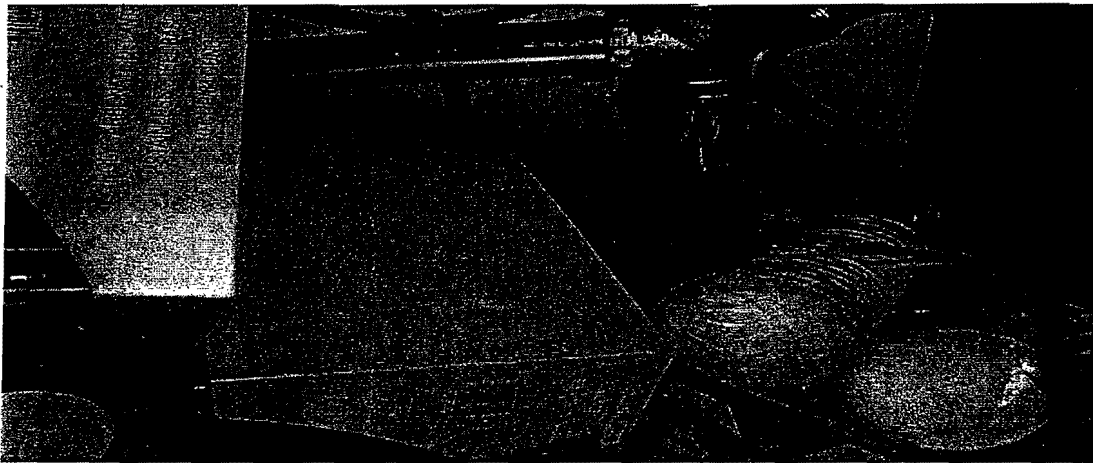

Photo 40: Room 122, Mold Under Sink.

An active water leak was found under the sink in the break room. Water was standing on the base of the cabinet and mold and water damage were visible on the bottom and back of the cabinet. Items stored under the sink were wet. The drain and water lines were inspected. The leak was traced to the sprayer and flexible hose attached to the faucet. The leak was at the base of the sprayer and water was found to drip at this connection any time the water was turned on to the faucet. Facility personnel were informed of the problem and the need for immediate attention.

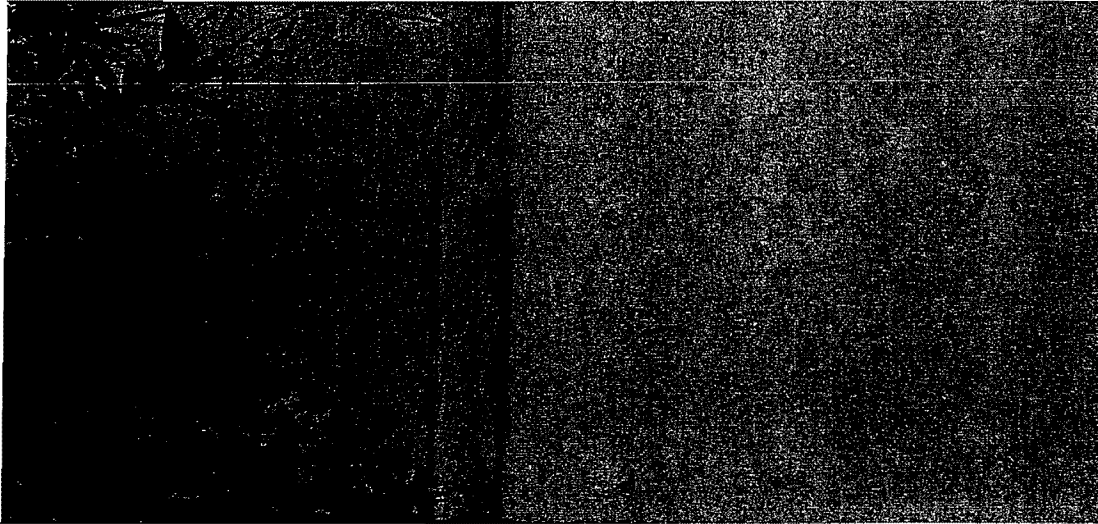

Photo 41: Base Building, Southeast Corner.

This photo shows a failed caulk joint between precast panels on the south wall of the base building near the southeast corner. At the tear, the caulking did not appear thick enough. Small cracks and checking can be seen in the caulk above the tear indicating the poor condition of the sealant. A hairline crack is visible to the right side of the joint and numerous voids in both panels indicate a porous surface and provide evidence of the need to apply a sealer to the concrete panels to prevent damage to the panels and moisture infiltration into the building.

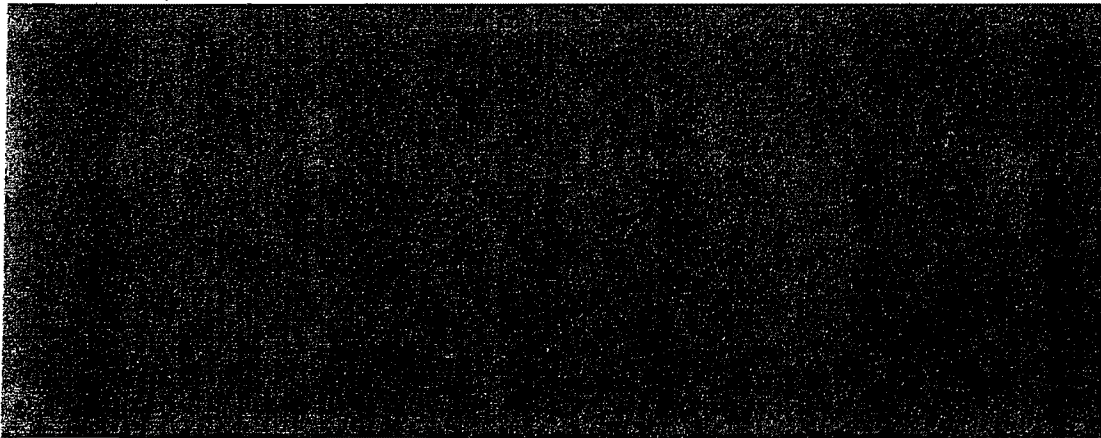

Photo 42: Base Building East Wall.

This photo is a close up of a precast panel on the east side of the base building. The precast panels appear to lack some quality control during the fabrication process as evidenced by numerous pieces of debris or impurities cast into the panel such as the piece of wood shown. The existing sealer is chalking and leaves residue on your hand after wiping the panel. The numerous voids allow water and moisture infiltration into the panel and likely allows higher humidity moist air into the building.

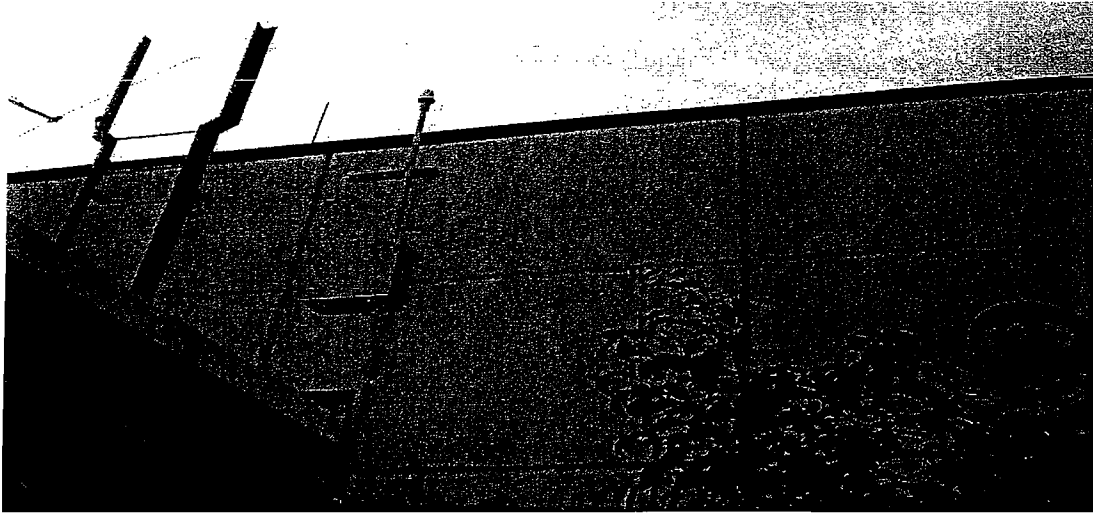

Photo 43: Base Building East Wall Above Canopy Door.

This photo shows the lack of a uniform application of sealer on the precast panels. The exposed aggregate is visible in the sections of the panels across the top of the wall. A line can be seen between the canopy roof and the surface mounted junction box where the application of sealer appears to stop again leaving exposed aggregate visible at the face of the panels. The sealer provides a uniform appearance of the panels but more importantly prevents the migration of moisture into the panels and into the building. The existing sealer is in poor condition and the quality and uniformity of the original application appears questionable.

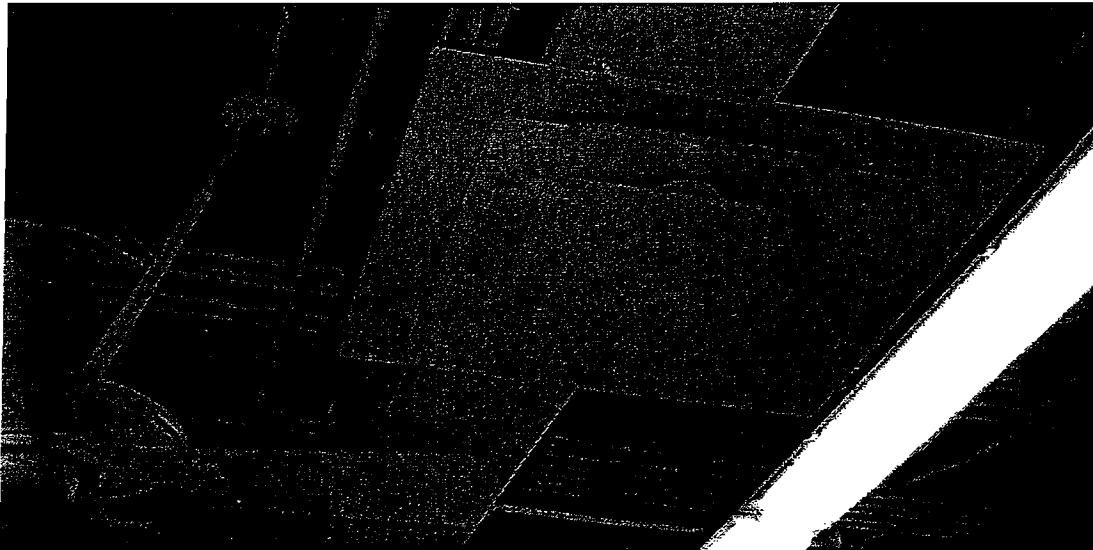

Photo 44: ESU Building Room 101, Moldy Air Diffuser.

Mold and dust were visible on the supply air diffuser. A regular maintenance schedule should be implemented to HEPA vacuum and wet wipe supply, return, and exhaust diffusers and grilles.

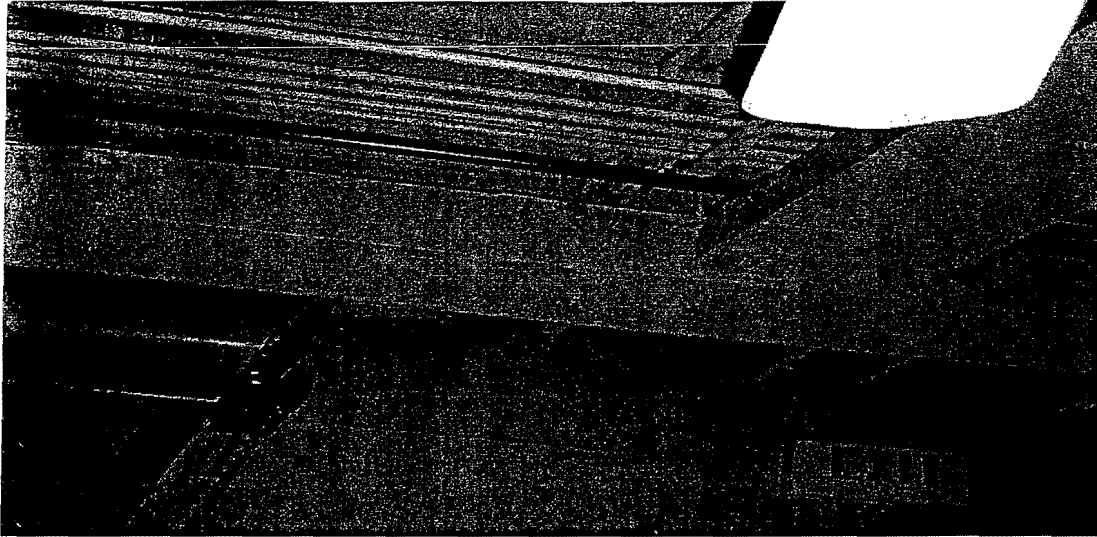

Photo 45: ESU Building Room 101, Mold on HVAC Ductwork.

Mold is visible on this section of ductwork. Air leakage at the Tee connection likely causes condensation on the duct providing moisture for the mold growth. Leaving the garage door seen in the background open for extended periods with warm/humid exterior conditions while the HVAC system is operating may contribute to the problem.

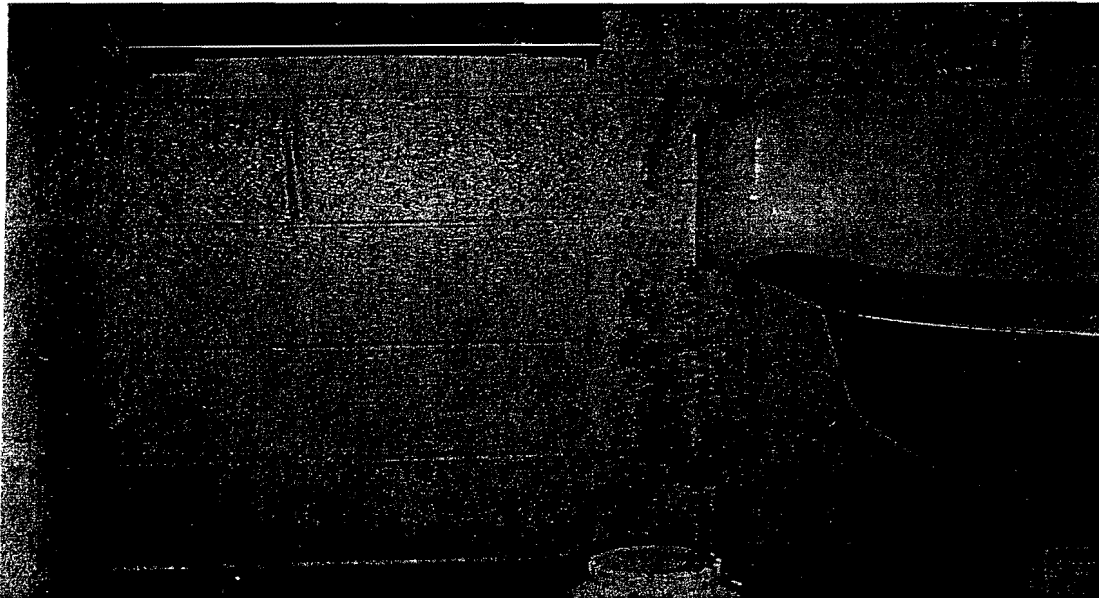

Photo 46: ESU Building Room 101, Mold on Wall by Sink.

Mold and dirt were visible on the wall below the soap dispenser at the janitor sink.

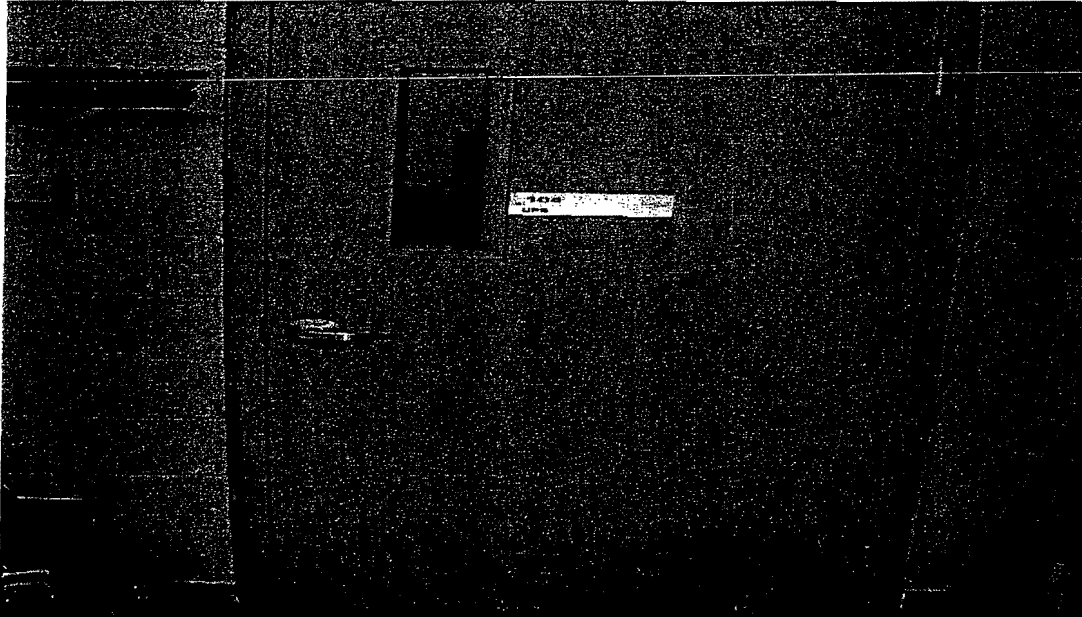

Photo 47: ESU Building Room 101, Mold on Door to Room 104.

Mold was visible on the surface of door 107 from the Work Room (101) to the UPS Room. The door is a standard non-insulated door with honeycomb fill. The PCS room on the opposite side of the door is maintained at a much lower temperature. This temperature difference, or possibly opening the garage door and exposing this door to warm humid outside air, causes condensation on the surface under the right conditions and this source of water supports the mold growth.



Photo 48: ESU Building, Room 104, Mold on Chilled Water Piping above CRU 5. Mold is visible on this section of chilled water piping at the valve. The vapor insulation and vapor barrier at this location are not continuous and result in condensation forming on the cold metal valve.

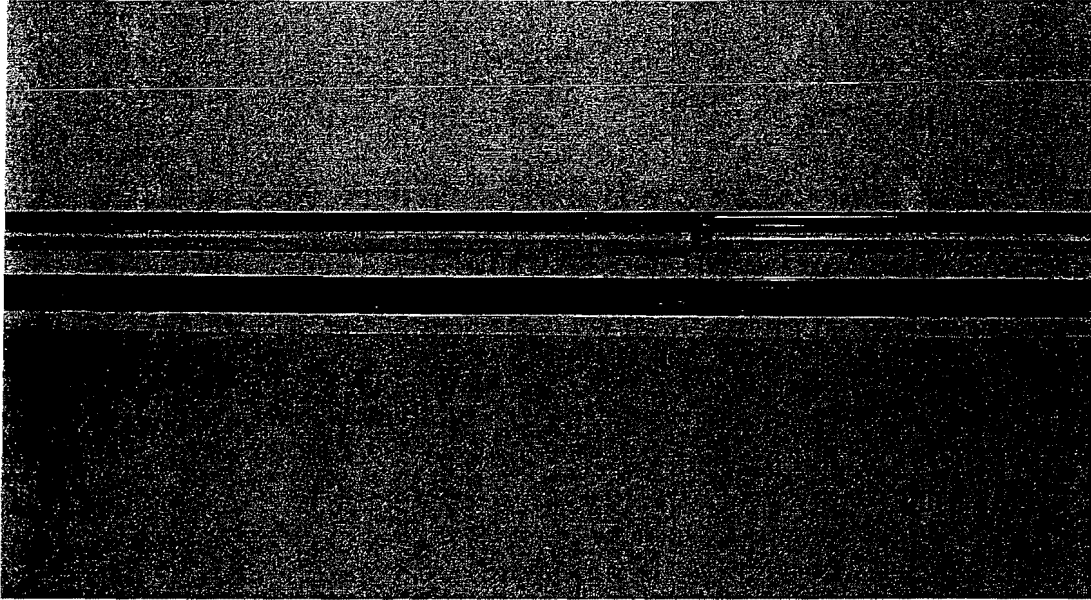

Photo 49: ESU Building Room 108, Mold on Ceiling Supply Air Diffuser. Mold can be seen on the perimeter supply air diffusers in the ESU building. Mold is also visible on the vinyl wall covering. Vinyl wall coverings were removed from exterior walls in the Base Building. It is recommended that all vinyl wall coverings be removed from the exterior walls in the ESU building.

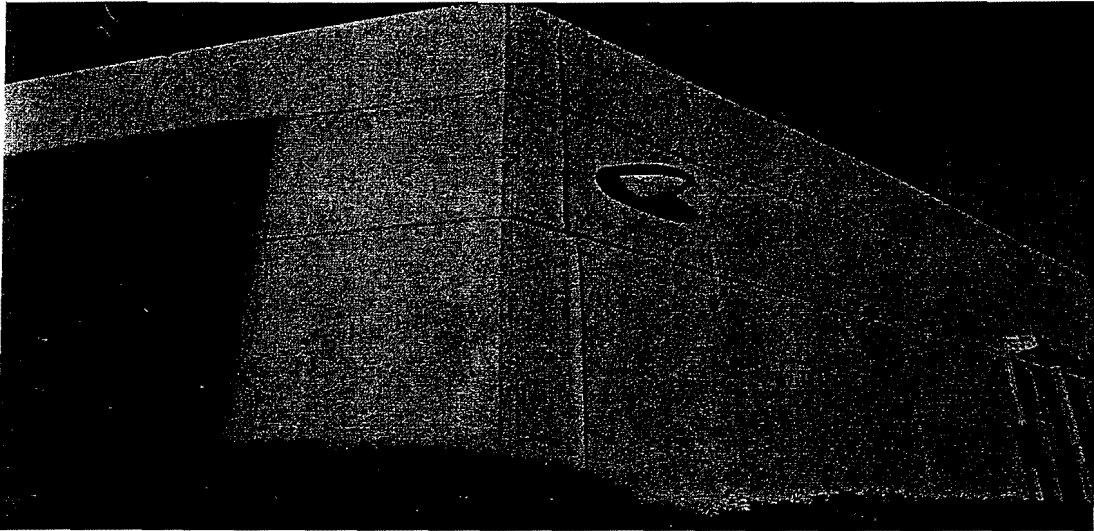

Photo 50: ESU Building, Southwest Corner. The caulk joint at this corner of the building as well as the southeast corner has failed. The caulk is becoming brittle and has cracked. The lack of uniformity of the original sealer can be seen across the precast concrete panels. It can also be seen that the panels are very porous and need to be sealed.

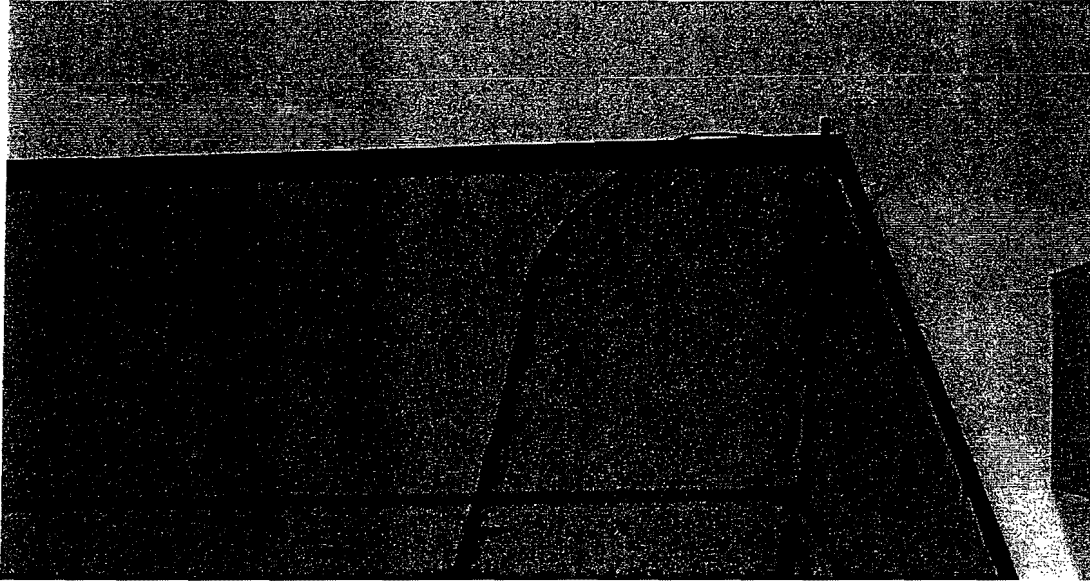

Photo 51: ESU Building, Northeast Corner.

The precast panels have cracked at the edges of corner panels at several locations. This provides an opening for water entry at the crack and will likely cause the sealant to fail at the cracked section providing a second point for water entry. Once the damaged concrete is removed, it will make it difficult to seal the joint since the face of the joint will vary with the remaining sound concrete. Tapering the edges of precast panels to a point similar to this detail will typically fail and crack.

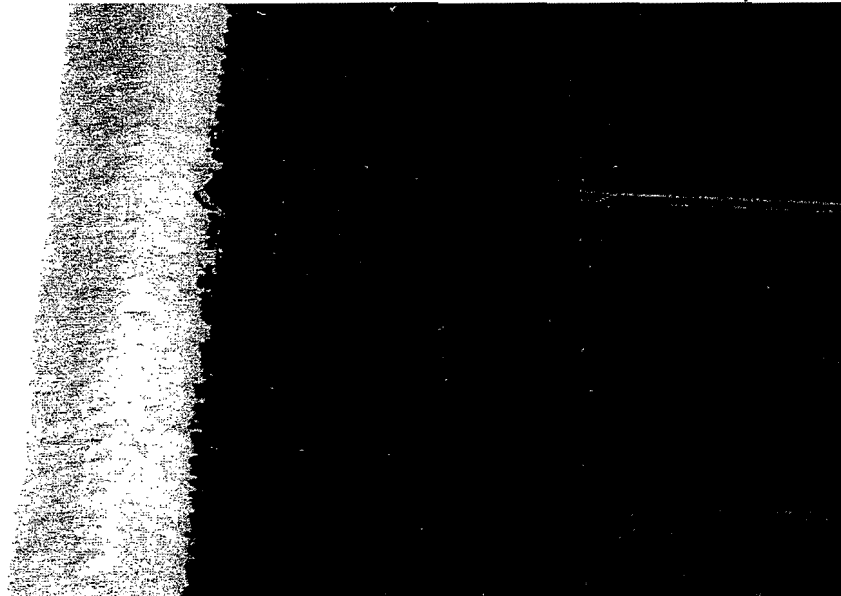

Photo 52: ESU Building East Wall, North side of South Window.

The sealant between the window and precast panel is obviously deteriorated and must be replaced.

30

TRIP REPORT

From: Ed Winkler, ACE-472

To: Steve Rethmeyer, Supervisor, Engineering Support, ACE-472

Date: December 7, 2006

Subject: Trip to St. Louis ATCT and Base Building to evaluate leaks and investigate for mold growth.

Executive Summary:

This inspection was of limited scope to look at several specific issues as well as to take a quick overall look at the facility to see if there were any obvious moisture or mold related problems similar to those found at MCI ATCT. Based on this quick inspection, it appears that there are significantly less problems evident with STL ATCT than MCI ATCT. It should be noted that there have been some extensive condensation and frosting problems in the base building that may have lead to mold growth in areas that are not easily detectable such as on the surface of gypsum board under wallpaper. It might be prudent to remove the wallpaper in one room that has experienced more condensation and frosting to help determine if we have a hidden mold problem. Mold was found on gypsum board walls or ceilings in rooms G6, 3TS5, and SJ7 of the ATCT and rooms 220 and 233 in the base building. A water damaged and mold contaminated cardboard box was found in the unfinished space behind the finished walls on the 8th floor of the ATCT. Evidence of water infiltration was found at the fourth floor outside air intake louver in the ATCT. Installation of a wind driven storm proof louver is recommended. Significant evidence of roof leaks was found on the second floor of the base building. The roof must be repaired promptly to prevent further water damage to building finishes or contents and to prevent the growth of mold on damaged surfaces. Once roof repairs are completed, all water stained ceiling tiles must be replaced to allow facility personnel to monitor the roof for leaks and ensure that the repairs were successful in preventing water leaks. It will be necessary to replace all joint sealant (caulking) on the exterior of the ATCT and base building within the next two or three years before the sealant fails in order to prevent water infiltration and mold growth.

This report makes some recommendations for additional actions that can be taken to investigate the potential for mold growth in suspect areas of the facility. The Findings and Conclusions section identifies the water related problems, identifies where mold was found, notes general observations made, and notes conclusions reached based on the inspection and findings. It also identifies recommended repairs and any additional inspection or evaluation that must be done to address the problems identified. The Recommendations section includes a summary or scope of work for mold remediation and restoration work identifying quantities and locations based on the findings of this inspection. Photographs and a brief narrative identifying the problems found and the recommended solutions are included in the appendix.

The following rough costs are provided as preliminary budget figures. Limited time was spent assessing the facility and in putting together these numbers. It is possible that more mold may be found once work begins and walls are cut open or wallpaper is removed.

| | |
|---|---------------------|
| ATCT and Base Building Sealant Replacement (2008/09 cost) | \$175,000 – 200,000 |
| Roof Repairs (including new access hatch) | \$21,000 |
| Replace Water Stained Ceiling Tile | \$2,000 |
| Replace Outside Air Intake Louver | \$4,000 |
| Mold Remediation and Restoration | \$35,000 |

The sealant replacement needs to be completed within 2 or 3 years prior to sealant failure and leaks occurring. The remaining work (\$62,000) needs to be completed as soon as possible. Since portions of the facility were inaccessible and there is a good chance of finding additional problems during remediation, recommend identifying \$70,000 to cover the cost of this portion of the required work.

Background:

I received a call from Sue Jarrett, ACE-473, concerning water or moisture related problems involving several pipe leaks, possible condensation problems on piping, and leaks around the base building roof hatch. Sue requested assistance in evaluating these water related problems and in assessing whether or not there were any mold related problems. Sue also requested that I look at the ATCT to see if I saw any water damage or mold problems similar to those found at MCI ATCT since both towers are of the same design.

Barbara Hebert (ACE-471), Tom Orr (ACE-472), and Ed Winkler traveled to the St. Louis Airport Traffic Control Tower (STL ATCT) on November 6, 2006 to evaluate areas of the facility with known water related problems and also conducted a quick visual inspection of the facility for any other obvious water related or mold issues.

Findings and Conclusions:

The inspection consisted of a one-day trip to the facility. Visual inspection was utilized to identify areas where moisture or mold might be of concern. Vinyl cove base was pulled loose to inspect the gypsum board wall behind it for water damage or mold at suspect areas. In a few instances, a very small section of gypsum board was cut out behind the base to allow inspection of the back side of the gypsum board or the concealed layer on fire rated walls with multiple layers of gypsum board. One bulk sample and one tape sample were collected to test for the presence of mold. Photographs were taken during the inspection. Selected photos with a brief narrative are included as an appendix to the report. References to photos are included in this section of the report.

The inspection began in room BL2 in the basement of the ATCT shaft. A section of the suspended ceiling was boxed down below piping on the east side of the elevator shaft. This piping continues up the tower shaft through an inaccessible pipe chase. Water stains were visible on the ceiling tile below. Sue indicated that some water stained tiles had previously been replaced. No

signs of active leaks or condensation were found during the inspection. The chilled water piping is insulated predominantly with fiberglass insulation with a paper vapor barrier jacket. Some valves and the lower portion of the piping near the ceiling grid were insulated with Armaflex insulation. It appears that the source of water is from condensation on the chilled water piping due to gaps or breaks in the vapor barrier. At one location, a plumbing vent crosses the vertical chilled water pipes and due to close proximity shares the same insulation. The vapor barrier jacket is not a tight fit nor is it fully sealed at this location. There appear to be some gaps in the vapor barrier jacket where the Armaflex insulation and fiberglass insulation meet. The ceiling grid beneath the pipes at the bottom of this chase interferes with completely insulating the pipes at this location and may allow gaps or breaches in the vapor barrier. This area will need further inspection whenever water is found on the ceiling tiles in order to pinpoint where it is originating. Gaps or breaches in the vapor barrier jacket are a likely cause of condensation. If the condensation is forming above the basement level it will be very difficult to locate the source since the piping is in an inaccessible shaft. The installation of access doors may be required to locate the problem. It would be ideal to have access doors to allow for inspection of all concealed piping. There are also drain lines routed through concealed spaces on the Subjunction level.

The next area inspected was the smokeproof stair vestibule, G6. A leak in the fire protection piping had been repaired above the gypsum board ceiling in the vestibule. Upon entering the vestibule, water damaged and stained gypsum board could be seen on the ceiling and water streaks/stains were visible running down the west wall (photo 1). The gypsum board ceiling had delaminated and crumbled leaving a sagging section where water from the leak had previously saturated the ceiling. The top side of the gypsum board ceiling and the top of west wall above the ceiling were inspected through an access panel in the ceiling. Mold was visible on portions of the gypsum board ceiling. The area of water damage and contamination was measured. The vinyl base was pulled loose on the west wall below the water stains to determine if sufficient quantities of water had run down the wall or accumulated on the floor along the wall and caused water damage or mold. No apparent water damage or visible mold were found on the west wall.

The inspection continued in stair 233. We were informed that there had been numerous leaks around the roof hatch and that the gasket on the hatch had fallen off or had been damaged and replaced. Upon entering the stairway, water damage was obvious by peeling paint on the east wall near the fixed ladder to the roof (photo 2). Approximately six ceiling tiles in the stairway showed water stains from previous leaks. More extensive water damage was found on the gypsum board around the enclosed shaft through the suspended ceiling. Facility personnel indicated that water damaged ceiling tiles in the stairway had been previously replaced. Based on this information as well as additional observations during the trip, it appears that there are some active roof leaks causing damage to the building and contents that must be located and repaired. Visual inspection of the roof hatch revealed an oversized opening to the exterior where daylight was visible that allows the exchange of warm and cold air. The opening serves as the strike plate and receiver for the locking mechanism on the hatch. The hatch itself consists of a single layer of uninsulated steel. Vinyl base was pulled loose on the east and south walls of the second floor landing at the base of the fixed ladder. The gypsum board on the east wall was installed with a small gap above the floor and no mold was found behind the base. Mold was found on the gypsum board behind the vinyl base on the south wall (photo 3). In this case, the gypsum board was installed in contact with the concrete floor. This allowed water to wick up the paper face on both sides of the gypsum board. Since it is a two-hour rated wall consisting of two layers of gypsum board on each face, a

small piece of gypsum board was cut out to inspect the concealed layers. Cutting out the gypsum board revealed mold on the back of the surface layer and on the face of the concealed layer. It appears likely that the roof hatch contributed to the moisture problem due to the damaged or missing seal/gasket. Water from leaks in the roof membrane is also likely to follow the steel deck and leak out at this or any other penetration of the decking. It is also likely that at certain times of the year condensation or frosting may occur on the surface of the uninsulated steel roof hatch and curb. Based on more extensive damage to the gypsum board in the hatch shaft, it appears that condensation is occurring. The drawing indicates that the roof hatch has a 2-hour rating but a label was not observed on the existing hatch indicating any rating. The quantities of water damaged or contaminated gypsum board were measured. A height for the contaminated gypsum board at the landing was approximated. It is possible that one or both of the layers of gypsum board on the corridor side of the south wall may be contaminated. The wallpaper on the corridor side of the wall was not disturbed in order to maintain the appearance of the facility and to avoid the potential for disturbing any mold that might be present since this is a heavy use area of the facility. Once the gypsum board in the stairway is removed, the visual inspection performed during remediation will be used to inspect the concealed layer of gypsum board on the corridor side of the south wall of stair 233. If mold is found at that time, the contract will have to be modified to address the additional work. It may be possible to price some additional work up front during the bidding process by using unit prices or by including some alternate work items on the contract and assuming quantities of work for these areas based on the best assumptions we can make before the job begins.

The inspection moved to room 217 where water leaks occurred around the overflow roof drain above the ceiling. Upon entering the room, water stains were visible on the ceiling tile and the wallpaper in the northeast corner of the room. Removal of the ceiling tile revealed heavily water stained and damaged pipe insulation on the drain line from the overflow roof drain (photo 4). A bulk sample of the heavily stained pipe insulation jacket was collected to test for the presence of mold and none was found. The back side of the gypsum board at the top of the column enclosure was visible and was inspected using a flashlight and mirror. No water damage or mold were apparent on the back side of the gypsum board. The vinyl base was pulled loose below the leak and no signs of mold or water damage were found. Facility personnel indicated that a roofer had checked the overflow drain and no leak was found at the drain body. The roofer removed some of the concrete pavers around this drain and found a hole caused by a piece of copper ground wire under the pavers that had punctured the membrane. It was also indicated that the facility would be obtaining quotes from a roofer to remove the pavers one section at a time and inspecting for and repairing any leaks found. The water stained pipe insulation continued beyond the limits of room 217. It was followed through stairway 218 and the corridor. Approximately 15 linear feet of water stained pipe insulation was found. A section of ductwork above the drain line in the corridor had heavy water streaks down the side of the duct and the bottom edge was heavily rusted. Further inspection revealed water stains around a weld on the roof deck above the duct where water from roof leaks had leaked through the membrane, traveled across the steel roof deck to the hole in the deck at the weld, dropped onto the top of the duct, ran down the side of the duct, and dropped onto the drain line and ceiling tile below. Inspection above the corridor ceiling also revealed an area where water had leaked through the steel roof deck where it was welded to a steel beam.

A quick walk over the roof was then conducted due to the evidence of leaks found thus far. Since the EPDM roof membrane is covered with concrete pavers, it is not possible to identify most problems without removing pavers and exposing the membrane. A quick inspection of one area of the roof surface found a screw, a triangular scrap of sheet metal, and a scrap of copper wire. If these types of debris are also below the pavers, there may likely be multiple small holes in the membrane causing leaks. Conducting a complete inspection of the membrane along with making any repairs found necessary makes sense based on the types of debris found, the recent membrane puncture repaired, and evidence of leaks found in the building. The roof should still be under warranty, which would cover obvious defects or failures. Repairs associated with small punctures are more of a gray area due to the age of the roof, due to the fact that it is difficult to identify who is responsible for leaving the debris on the roof, and since it could be argued that there was negligence or failure on the part of the FAA to inspect and maintain the roof. All perimeter metal flashing should be inspected and sealed if necessary.

While on the base building roof, caulked joints between precast panels on the ATCT shaft near the roof level were inspected. The urethane joint sealant was showing signs of breakdown from UV exposure, age, and movement. The sealant had multiple checks and cracks and was beginning to show some separation between the sealant and precast concrete panels. The deterioration is similar to that found at MCI ATCT although not quite as advanced as at MCI when leaks were occurring. Later in the inspection, joint sealant was observed between precast panels on the Junction Level Walkways. It was also showing signs of deterioration. A sealant replacement project for the ATCT and base building will be required within two or three years at the most.

Sue Jarrett indicated that at one time there had been a leak in the break room near the water line for the refrigerator. We began the inspection in room 220 at the 12" wide base cabinet next to the refrigerator. There appeared to be small amounts of mold visible and the particle board used to construct the cabinet had swelled up from water exposure. It appeared that it might be possible to clean any contamination in the cabinet with a biocide. The refrigerator was then pulled out. The vinyl base was pulled loose and the wallpaper was cut to allow for inspection of the gypsum board behind it. There appeared to be a very small amount of mold where the base cabinet and wall met. It will be necessary to remove the 12" wide base cabinet to determine the extent of any mold contamination behind the cabinet. It appears that replacement of any contaminated gypsum board would be predominantly limited to the area concealed behind the cabinet.

At this point in the inspection, Tom Orr and Sue Jarrett left for the day at the end of their shift. Barbara Hebert and I conducted a quick walkthrough of the remainder of the ATCT focusing on areas where mold or moisture problems had been found at the similar facility at MCI. The report will focus only on those areas where mold was found.

Mold was found behind the vinyl base on the west wall of the Subjunction Level Mechanical room, SJ7. A floor drain was installed adjacent to the gypsum board wall as a collection point for the discharge of drain lines from mechanical equipment such as humidifiers. The gypsum board was installed in close proximity to the concrete slab allowing water to wick up the paper facing. The quantity of contaminated gypsum board was measured.

Air shafts SJ6 and SJ8 were inspected. Some fireproofing debris and pigeon droppings were found on the floors of the air shafts and were partially obstructing openings in the drain grate

cover. The debris provides a food source for the growth of mold. These areas are exposed to water from the open microwave balconies above. Water from a drain on the microwave balcony is discharged directly onto the floor near an area drain in the bottom of the air shaft (photo 5). This water can roll back to the fireproofed steel columns where it is possible to enter the building or it can wet debris on the floor and lead to mold growth. The drain situation was improved at MCI by extending the drain pipe from the microwave balcony so that it discharged directly over the area drain and concrete was added to prevent water from rolling back into openings near the steel columns.

A cardboard box was found leaning against the sloped precast concrete walls in the unconditioned space beyond the access panel in the wall of stair vestibule 8TS6. The cardboard was warped from repeated water exposure and had areas of mold (photo 6). It appears that the source of water would be frosting or condensation on the interior face of the architectural precast panels. This area should be kept free of any paper based debris, which would support mold growth. The inspections and investigation at MCI ATCT indicate numerous areas within that facility, including this one, where condensation and frosting occur. Further evaluation at MCI as well as STL will be needed to determine the extent of the problem and corrective actions required.

A tape sample was collected at a suspect black spot on the south wall of room 8TS5A above the electric panels. Test results showed that mold was not present.

Some water stains were found on gypsum board walls enclosing the outside air ducts in room 4TS5. These ducts are adjacent to the outside air intake louver and plenum used to bring outside air into the lower portions of the tower shaft as well as make up air for the stair pressurization system. Mold was not found. This area was difficult to thoroughly inspect due to the large quantity of items stored in this space (photo 7). Inspection of the outside air louver and plenum revealed standing water on the bottom of the sheet metal plenum (photo 8). It appears that wind driven rains enter through the intake louver and collect on the bottom of the duct. This water can then travel down the inside of the duct leaking out at various joints or leak out at a joint at the plenum and travel down the exterior of the duct until dropping off at another location. Water from this leak could reach surfaces on any floor below since the outside air ducts serving floors below connect to the bottom of the plenum and penetrate the floor slab adjacent to the plenum. The existing louver is not a good storm proof louver and does not provide adequate protection against wind driven rains. A new wind driven storm proof louver will not necessarily keep out blowing or wind driven snow. The tower was constructed with an area floor drain in the fourth floor slab beneath the outside air intake plenum. The floor drain is not utilized since a drain was not installed in the bottom of the plenum. A drain could not be installed in the bottom of the plenum with the existing configuration of the plenum and branch ducts since one of the ducts enters on the bottom of the plenum and one enters immediately next to it through the side of the plenum. Modification of the plenum would be difficult and costly due to the existing duct and wall configuration, but may provide the best solution to address water infiltration at this location.

Evidence of several small leaks were found on chilled water piping in room 3TS5. Glycol stains were visible at several locations on the floor. Water stains were visible on some of the pipe insulation vapor barrier jacket. A small length of pipe insulation had visible amounts of mold on the vapor barrier jacket (photo 9).

Mold was found behind on the gypsum board behind the vinyl base in the southwest corner of room 3TS5 adjacent to the outside air ducts (photo 10). The source of water appears to be from water infiltration through the outside air intake louver located through the exterior wall on the floor above. Since water was found in the bottom of the outside air plenum after the recent rains, the louver is likely the source as opposed to the joint around the perimeter of the louver.

Recommendations:

Caulk joints between precast panels were inspected at several places on the tower shaft. The caulking is beginning to show signs of splitting, cracking, separation, and breakdown. All sealant on the tower and base building must be replaced within two or three years to prevent water infiltration and mold problems similar to those encountered at MCI ATCT. It will be necessary to get this item in the budget and to make it a funding priority. The entire facility should be inspected periodically with a walkthrough and visual inspection of all areas after a heavy rain to check for leaks. If any leaks are found, measures should be implemented to keep building materials and components dry or to ensure they are dried quickly after a leak. Once a leak is found, more frequent inspections of these areas should be conducted.

A complete inspection of the base building roof must be performed and all repairs needed must be completed. This action is necessary since several locations were found where water had leaked through the EPDM membrane and entered the building at openings in the steel deck. Numerous stained ceiling tiles were observed on the second floor. Some tiles have been replaced and stains are once again visible. Debris was found on top of the pavers that could ultimately work its way down to the membrane and damage the roof. The roof is covered with concrete pavers. The pavers and protective mat below must be removed in sections to allow for inspection of the entire roof. The flashing on all penetrations must also be inspected. All perimeter metal flashing must be inspected. Any damage or defects found must be repaired. The roof hatch should be replaced in conjunction with the repairs. See additional information under the recommendation for stair 233 below.

Replace all water stained ceiling tiles after roof repairs are completed. This is the only effective way to ensure that the roof work completed fixed the problem and we do not have any active roof leaks. It will also allow any new water stains that appear to be investigated and allow for a determination of the cause such as a roof leak, pipe leak, etc.

4th Floor Outside Air Intake Louver: Water infiltration must be corrected at the outside air intake louver located on the fourth floor. Recommend replacing the existing intake louver with a wind driven storm proof louver. This should significantly reduce water infiltration through the louver. If the stair pressurization fan is operated during periods of rain, water may be pulled into the building due to the large increase in the volume of air being introduced into the building through this louver. Recommend that the stair pressurization fan not be tested during periods of rain or snow since the large volume of air being moved might introduce water into the building. It may be possible for blowing snow to enter the new louver, but the quantity will be less than that of the existing louver. After the new louver is installed, the outside air plenum will have to be observed during several periods of snowfall to determine if snow is entering the building and additional corrective actions are required. Installing a new louver and adding a drain to the plenum to direct

any water to the area drain on the floor below the duct would be best solution. It is not recommended to modify the existing plenum and ductwork to install the drain at this time due to the cost, difficulty, complexity, and limited working space. Modifying the ductwork and plenum would require removal of walls, patching and cutting new openings in the floor, and extensive modifications of the ductwork. Replacing the louver should solve most of the problem and must be done even if modification of the plenum is required later. It will be more cost effective to do only this portion first as it may correct the problem.

Piping, Room BL2: Recommend modifying and lowering the boxed out suspended ceiling soffit/fascia below the pipes to allow more space to adequately insulate the bottom of the chilled water lines. Recommend reinsulating sections of the chilled water piping where there are gaps in the vapor barrier or anywhere the vapor barrier does not appear to be continuous. Provide additional insulation at valves to prevent condensation that is installed in a manner to allow easy access to the valves and reinstallation when maintenance activities are completed. Once these repairs are completed, install new ceiling tile to replace stained tile. The ceiling will have to be observed for signs of new leaks and the piping inspected if new water stains are found. It is possible that there could be a problem with condensation at multiple locations in the inaccessible chase above. If it is determined that water is originating on the piping or insulation above the floor slab overhead, it will be necessary to install fire rated access panels at alternate floors up the full tower shaft to isolate and locate the problem. As the tower ages, it would be ideal to have these access points for routine and emergency inspection of all concealed piping.

Smokeproof Stair Vestibule G6: Remove and replace entire ceiling, approximately 5'-4" x 7', with Dens Armor Plus gypsum board. Tape, finish, prime, and paint ceiling. Clean water stains on west wall. Reglue cove base removed during inspection. Repaint all walls in vestibule. Replacement of the entire ceiling is recommended over replacement of the 8 square feet (SF) of contaminated and water damaged area since future leaks are possible at this location and the new gypsum board is much less susceptible to mold growth.

Stair 233: Replacement of water damaged ceiling tile is covered by a previous recommendation. Replace contaminated and water damaged gypsum board around four sides of the shaft from the suspended ceiling to the roof hatch with Dens Armor Plus. Quantities are as follows as measured with the height beginning from the hatch downward. North side is 36" wide by 4'-5" high. West side is 30" wide by 4'-5" high. South side is 36" wide by 4'-5" on the surface layer and 36" wide by 4' on the concealed layer. East side is 30" wide by 21" high on the surface layer and 30" wide by 18" high on the concealed layer. Replace contaminated gypsum board at the base of the south wall (2-hr rated wall) from SE corner to corridor door. This is approximately 4.75 linear feet (LF) by 4' high on the surface layer and 3' high on the concealed layer. Tape, finish, and prime new gypsum board. Reglue cove base on the east wall. Install 4.75 LF of new cove base on the south wall. Paint all gypsum board at shaft to roof hatch. Repaint entire south wall at second floor landing. Sand, patch and repair peeling paint on east wall and repaint entire east wall to landing below. Install new insulated 2-hr rated roof hatch.

Room 217: Replacement of water damaged ceiling tile is covered by a previous recommendation. It appears that there was no mold on gypsum board walls, but there is water stained wallpaper in the NE corner of the room. Remove water damaged wallpaper to inspect concealed gypsum board for visible mold. If the facility has matching spare wallpaper, recommend reinstalling wallpaper

in this corner. If there is no matching wallpaper on site, recommend removing all wallpaper in room 217 and 217A and painting the rooms instead of using wallpaper. This would also allow for an inspection of the concealed exterior gypsum board walls for mold which may be prudent to do since there have been a lot of condensation issues with the windows in the building. Wallpaper is not the best finish for exterior walls as it often serves as an additional vapor barrier and that sometimes leads to mold growth beneath the wallpaper. The pipe insulation on the overflow roof drain above the ceiling is badly water stained and deteriorated and the vapor barrier is not intact. Water damage continues on the insulation as it is routed through stair 218 and across the corridor. Replace approximately 15 LF of pipe insulation on the overflow roof drain line.

Room 215 or 217: As noted in the paragraph above, recommend removing wallpaper in one of these rooms or another in the facility that has had leaks or condensation to check for hidden mold. Patch, repair, and paint walls. Replace any contaminated gypsum board found. Installation of new vinyl wallpaper is not recommended on exterior walls as it tends to add a second vapor barrier and could lead to mold growth on the gypsum board.

Room 220: Recommend removing the existing 12" base cabinet next to the refrigerator to allow for inspection and likely remediation of the concealed wall behind it. It appears that the mold in the cabinet can be removed through use of wet wiping and a biocide. If mold damage is not too heavy on the concealed portions of the cabinet (underside of bottom and rear of back panel), cleaning is possible. Utilize a contract option price to replace the cabinet if the visual inspection, once the cabinet has been pulled out, shows cleaning is not feasible. It is assumed that a small quantity of gypsum board (approximately 4 SF) may have to be replaced behind the cabinet. In order to minimize cost, this can likely be done by peeling back the wallpaper behind the refrigerator and regluing it in place once the wall has been repaired. The area behind the refrigerator is not very visible so the appearance of the repair does not have to be as perfect as that in an exposed area.

Mechanical Room SJ7: Recommend removing and replacing a section of contaminated gypsum board on the west wall between the bottom of the concrete stairs and the concrete curb at the base of the sloped south wall. Remove a section of gypsum board 5.33 LF by 24" high and replace with cement board. Tape and finish joints. Install fiberglass reinforced panels (FRP) with all manufactured trim components on the wall over an area of 6 LF by 3 feet in height. Clean floor and seal bottom of FRP at floor and seal FRP at top edge. Cement board and FRP are recommended since this is a wet area with a floor drain and multiple drain lines adjacent to a gypsum board wall. The use of FRP will eliminate the need for any painting in this area during the restoration portion of the project. Install 6 LF of new vinyl cove base on the west wall. Recommend investigating a modification of the drain lines to minimize splashing and water on the wall. One possible solution would be running the drain lines into a funnel placed directly over the floor drain.

Air Shafts SJ6 and SJ8: Recommend cleaning the floors of the shafts to remove accumulated fireproofing debris or pigeon droppings since these are wet areas and these debris are a food source for mold growth. Recommend extending the existing drain lines serving the junction level microwave balconies above so that they discharge directly above the area drain in the shaft floor. Recommend installing a curb to hold water on the floor near the area drain and to prevent water on

the floor from rolling back to the building wall or structural steel and entering the building. Recommend regular inspection of the drains to ensure they are not blocked.

Concealed space at 8TS6: Recommend facility personnel dispose of the water damaged and mold contaminated cardboard box left as trash in this space. The surface of the precast concrete walls in this location either condense and/or frost during the winter months. It will be necessary to observe this space during the winter months to see how much condensation or frost occurs on the precast walls and if there is a sufficient accumulation of water from condensation and frosting to run down the exterior precast walls and wet building materials at lower elevations. Evaluation of the condensation and frosting issue is ongoing at MCI ATCT for this space as well as other unconditioned spaces throughout the tower shaft.

Room 4TS5: The room was full of stored materials making it very difficult to access or visually inspect any of the walls. There were some small water stains or streaks on gypsum board near the outside air ductwork. No mold could be seen. A complete inspection of this room should be conducted in the future when the space is cleaned out and accessible. It is recommended that storage be minimized or eliminated in nonfunctional spaces within the tower shaft as it prevents problems from being detected at an earlier stage, provides additional materials that could become wet and be a food source for mold, adds a fireload to the building, and does not meet the intent of 29 CFR 1960.20 which does not allow combustible materials other than necessary furniture and office supplies in the tower. Other unoccupied areas of the tower shaft also had significant amounts of stored items, which make conducting a full inspection challenging or not completely possible due to the difficulty of moving numerous items with limited manpower and time available to complete the inspection.

Room 3TS5: Recommend removal and replacement of contaminated vinyl cove base and gypsum board in the southwest corner of the room. Removal and replacement begins at the south side of the outside air duct down through the slab and extends to the south 1.5 LF on the west wall and 1.3 LF (or to next stud) on the south wall to a height of 4 feet. The mold visible on the surface of the gypsum board was relatively minor. The removal height of 4' was selected to ensure that the concealed side of the gypsum board can be inspected during removal and is not contaminated since water may be running down the back of it from leaks at the outside air intake louver and plenum on the floor above. The visual inspection conducted during the remediation process will verify if a change order is necessary to remove additional gypsum board. Install new Dens Armor gypsum board. Tape, finish, prime, and paint. Install new cove base.

General Recommendations: Recommend conducting a complete inspection of the facility on a monthly basis to document any instances of water infiltration or leaks within the building. Attention should be paid to all walls and ceilings around openings such as doors, windows, louvers, etc. Corrective action should be taken in a timely manner to eliminate the source of water and to replace or repair building materials so that signs of a new leak will be obvious. Water stained and damaged pipe insulation should be replaced and repairs made as they are discovered. Insulation on chilled water piping or equipment removed to operate valves, perform maintenance, etc. must be promptly and correctly replaced with the vapor barrier in tack to prevent condensation.

Appendix:

The attached appendix contains ten photographs of the facility referenced in the report.

3

1

STATEMENT OF WORK

MICROBIOLOGICAL REMEDIATION

FOR

FEDERAL AVIATION ADMINISTRATION

ST. LOUIS AIRPORT TRAFFIC CONTROL TOWER (STL ATCT)

ST. LOUIS, MISSOURI

1.0 WORK SUMMARY. The Contractor is required to furnish all labor, materials, services, equipment, insurance, and perform all the work to remove and dispose of all microbiological contaminated materials (MCM) and microbiological contaminated elements (MCE) described in this scope of work. The Contractor shall be responsible for the cleanup and removal of microbiological-contaminated wallpaper, gypsum board, and pipe insulation (including water stained or damaged) in the STL Base Building Rooms 215, 217, 218, 220, 221, 233, and 235, and the STL ATCT Rooms G6, 3TS5 and SJ7 in accordance with the guidelines established by the New York City Department of Health entitled *Guidelines on Assessment and Remediation of Fungi in Indoor Environments* (GARFIE) attached and incorporated herein by reference (See Attachment 1). Included in the scope of work is the removal of any MCM between the bottom metal runner/track and the concrete floor and between the top metal runner/track and the structural deck. The Contractor shall minimize dust generation and use the methodologies outlined in GARFIE for dust prevention and suppression. Prior to performing microbiological remediation procedures, the Contractor shall seal all critical penetrations and openings to the work areas with a minimum of 2-layers of 6-mil polyethylene. Additionally, the Contractor shall be responsible for ensuring adjoining areas are not exposed to the microbial contamination during the remediation. The Contractor shall provide additional cleaning procedures as described herein in Rooms 217, 218, 221, BL2, SJ6, SJ8, and 4TS5. A complete list of the work required is included in Section 7.0 Work Procedure and the Supplemental Statement of Work (SSOW). All Base Building MCM removals, painting, and other cleaning procedures shall be conducted at night between the hours of 6:00 PM and 6:00 AM. The facility shall be suitable for restricted/normal re-occupancy by 6:00 AM each morning. Negative air pressure equipment shall be equipped with a HEPA filter and discharged outside of the building whenever possible, otherwise discharged through a second HEPA filter in order to permit recirculation of air inside the building. See SSOW for additional requirements and work required to restore the facility.

1.1. CONTRACTOR'S RESPONSIBILITY. The Contractor shall perform all work required to give a complete and satisfactory job as required by this statement of work. The Contractor shall be responsible for performing this scope of work in accordance with GARFIE. The Contractor shall perform the work per the schedule and sequence identified in the SSOW. The Contractor shall be responsible for all debris generated under this contract at the job site and during transport of microbiological containing or contaminated materials to the FAA dumpster.

- 1.1.1 **Site Visit.** The Contractor is responsible for inspecting the work space and field verifying all quantities for: constructing a negative pressure enclosure for each phase of the work, MCM, MCE removal and disposal, work area physical parameters, access limitations, and Government phasing limitations. The Contractor shall be required to work around existing furniture, fixtures and finishes during the performance of this contract. The site visit shall be scheduled by the Government for interested microbiological remediation Contractors to identify specific work area and phasing requirements.
- 1.1.2 **Property Damage.** The Contractor shall take all precautions to avoid damage to Government property or equipment. Any damage to Government property by the Contractor shall be repaired by the Contractor to its original state or better condition at no additional expense to the Government.
- 1.1.3 **Working Conditions.** The Base Building and portions of the ATCT will be occupied and Government operations will continue on a normal, temporary, or restricted basis for the duration of the project. The Contractor shall take all precautions to ensure that their operations are conducted in a manner that does not interfere with the normal operations of the surrounding facilities and the safety and health of the occupants or the environment. Contractor's personnel will have limited access to the facility.
- 1.1.4 **Cleanup.** Upon completion of the work at the site, all staging and debris from the project shall be removed from the site and disposed of properly. The entire area shall be left clean and acceptable to the Government.
- 1.1.5 **Certifications.** The Contractor shall be certified by the Indoor Air Quality Association (IAQA), the Institute of Inspection, Cleaning and Restoration Certification (IICRC), the National Duct Cleaning Association (NADCA), or equivalent.
- 1.2. **SCHEDULE.** See contract documents for duration of contract and notice to proceed.
- 1.2.1 **Pre-Construction Meeting.** The Contractor shall attend a mandatory pre-construction meeting before starting work and the Government will schedule the meeting.
- 1.3. **TEMPORARY FACILITIES AND STAGING AREA.** The electrical energy and the water consumed shall be provided by the Government at no cost to the Contractor from existing lines and sources located in the Base Building or ATCT or from services adjacent to the work areas. Contractor's use of utilities shall be coordinated with the Government. Contractor is responsible for ensuring that adequate electrical power and water are available to complete the work. The Contractor will be permitted to use the areas as directed by the Government for

staging and storage of materials, although minimal space will be available. The area is restricted to uncontaminated work equipment and supplies. The area shall be left clean and restored to the same condition as when accepted by the Contractor.

1.4. SUBMITTAL REQUIREMENTS. The Contractor will submit the following materials to the Government for review and approval prior to starting work:

- Material Safety Data Sheets for all chemical products (including detergents).
- Respiratory Fit Test and Medical Surveillance for employees scheduled for this project.
- HEPA Vacuum Specification Sheet.
- Negative Air HEPA Filter Specification Sheet.
- Proposed Phasing Schedule.
- Configuration of typical negative enclosure system and location for each phase.

2.0 MEDICAL REQUIREMENTS. Contractor shall provide medical surveillance and have a written Respiratory Protection program in place as required by 29 CFR 1910.134 for all personnel engaged in the removal and demolition of MCM and MCE. Respirators and filters provided shall be NIOSH approved and provide the appropriate level of protection.

3.0 PROTECTIVE CLOTHING. Contractor shall provide workers and government representatives with sufficient sets of protective full body clothing. Such clothing shall consist of full body coveralls including head covers, foot covers and hand covers. Contractor shall provide additional personal protective safety equipment as required by applicable OSHA safety regulations.

4.0 REMEDIATION AREA. Contractor shall establish a remediation area and restrict the access to the microbiological work areas during work conducted in the Base Building or ATCT. Contractor shall establish a roped-off perimeter and provide warning barrier tape and signs outside the perimeter of the negative pressure enclosure system. Contractor shall establish a negative pressure enclosure system by sealing all critical penetrations or openings to the work area with a minimum of two layers of six-mil polyethylene. Negative pressure enclosure shall have a minimum of four air exchanges per hour and shall be maintained and recorded with a magnehelic gauge or equivalent device under a minimum negative pressure differential of -0.02 inches of water relative to adjacent non-work area space. Negative air pressure equipment shall be equipped with HEPA filters and exhaust shall be discharged outside the building, a minimum of 25 feet from building access points and building make-up air sources, or wherever necessary, negative air pressure equipment shall be equipped with a HEPA filter and exhaust shall be discharged through a second HEPA filter in order to permit recirculation of air inside the building. Personnel shall wear and utilize protective clothing and equipment in the regulated area as specified herein.

5.0 DECONTAMINATION AREA. Contractor shall establish a decontamination unit for passage to and from the work area during remediation operations in order to minimize the leakage of mold-contaminated dust to the outside. This unit shall consist of a minimum of two chambers, including a clean room and equipment room separated by airlocks. The airlocks shall be formed by overlapping three sheets of 6-mil polyethylene sheeting at the exit of one room and three sheets at the entrance to the next room, with three feet of space between the barriers. Airlocks shall be constructed to effectively maintain negative pressure while not inhibiting worker egress in an emergency situation.

6.0 WORKER PROTECTION PROCEDURE.

6.1. Each worker and authorized visitor shall, upon entering the job site, put on appropriate respirator and clean protective clothing, before entering the work area.

6.2. Each worker and authorized visitor shall remove gross contamination from clothing by HEPA vacuuming, prior to leaving the regulated work area. After decontamination of protective clothing, while still wearing the respirator, remove protective clothing and dispose as microbiological waste, as appropriate, in a drum or two layers of six-mil polyethylene disposal bags.

6.3. Workers shall not eat, drink, smoke, or chew gum or tobacco at the work site. Workers shall be fully protected with respirators and protective clothing immediately prior to the first disturbance of MCM or MCE and until final cleanup is completed.

7.0 WORK PROCEDURE.

7.1. Moisture damage restoration and mold remediation shall be conducted as necessary and as described in Rooms 215, 217, 218, 220, 221, 233 and 235 (Base Building) and Rooms G6, 3TS5 and SJ7 (ATCT).

7.2. Prior to performing microbiological remediation procedures, the Contractor shall seal all critical penetrations and openings to the work area. Establish phasing schedule with Government for each days work activity. Contractor shall HEPA-vacuum and/or wet wipe with a detergent solution all non-porous furniture and fixtures. Contractor will remove any furnishings from the remediation area after it has been pre-cleaned. Upon completion, the Contractor will return the furnishings to the original location. If necessary, furnishings can be pre-cleaned and wrapped with two layers of 6-mil polyethylene and allowed to remain in the remediation area. Electrical equipment that poses an electrical hazard shall be HEPA vacuumed only.

7.3. Maintain a minimum of four air exchanges per hour within the remediation work area and a minimum negative pressure differential of -0.02 inches of water, continuously recorded by use of a magnehelic gauge or equivalent device. Negative air pressure equipment shall be equipped with a HEPA filter and discharged outside of the building whenever possible, otherwise discharged through a second HEPA filter in order to permit recirculation of air inside the

building. Contractor will secure entrance into the regulated area at the conclusion of each workday.

- 7.4. The scope identifies partition types, such as fire rated partitions, and the number of layers of gypsum board. Removal limits shall coincide with existing metal studs at or beyond the limits identified below. Where multiple layers of gypsum board are indicated, joints between gypsum board on the surface and concealed layer shall be staggered horizontally and vertically, unless limits are the entire wall and less than the length of the gypsum board utilized. Demolition work shall be conducted utilizing methods to minimize noise and the spread of dust, such as the use of HEPA vacuums at the point of cutting and/or tools with shrouds or boots connected to a HEPA vacuum. See SSOW for additional requirements. The locations and approximate quantities for gypsum board remediation are listed below:

In Room 220, gypsum board totaling approximately three square feet will be removed. The 12" base cabinet next to the refrigerator shall be pulled out to allow for inspection of the concealed wall behind it. On the east wall, this area includes a section of gypsum board behind the refrigerator and cabinet, approximately 2' wide to a height of 18". The cabinet shall be taken outside of the facility and cleaned with a biocide. If any visible mold remains after cleaning, a price may be requested to remove and replace portions of the cabinet such as the shelf, side panel, or the back panel of the base cabinet. Contaminated components will be removed and replaced if the vast majority of the cabinet can be salvaged. Otherwise, it shall be discarded and replaced in its entirety. See contract option 1.

In Room 233, gypsum board and insulation totaling approximately 90 square feet will be removed. This area includes the four sides of the shaft from the suspended ceiling to the roof hatch and on the bottom of the south wall. Height dimensions in the roof hatch shaft are measured from the hatch downward. The north side is 36" wide by 4' 5" high; the west side is 30" wide by 4' 5" high; the south side is 36" wide by 4' 5" (surface layer) and 36" wide by 4' high (concealed layer); and the east side is 30" wide by 21" high (surface layer) and 30" wide by 18" high (concealed layer). On the bottom of the south wall, this area begins in the southeast corner extending to the corridor door, 4.75' wide to a height of 4' (surface layer) and 4.75' wide to a height of 3' (concealed layer).

In Room G6, gypsum board totaling approximately 35 square feet will be removed. This area includes the entire ceiling from the north wall to the line formed by the south edge of the rough opening for the ceiling access panel. The west wall shall be wet wiped with a detergent solution to clean existing water stains.

In Room 3TS5, gypsum board totaling approximately 11 square feet will be removed. On the west wall, this area begins at the south side of the outside air duct extending southward, 1.5' wide to a height of 4'. On the south wall, this area begins in the southwest corner extending eastward, 1.3' wide to a height of 4'.

In Room SJ7, gypsum board totaling approximately eight square feet will be removed. On the west wall, this area includes the portion between the bottom of the concrete stairs and the concrete curb at the base of the sloped south wall, 5.3' wide to a height of 18".

- 7.5. In Rooms 215 and 233, a containment and negative pressure enclosure system shall be established as described in Section 4.0 Remediation Area. A decontamination unit shall be established as described in Section 5.0 Decontamination. Upon completion, the work area shall be HEPA vacuumed and then wet wiped with a detergent solution.
- 7.6. In Room 220, a mini containment shall be established consisting of a single layer of 6-mil polyethylene sheeting but a negative pressure enclosure system is not required. Mist and cover any contaminated areas prior to removal. Upon completion, the work area shall be HEPA vacuumed and then wet wiped with a detergent solution.
- 7.7. In Rooms 3TS5, and SJ7, the work area shall be unoccupied, however, a containment and negative pressure enclosure system are not required. Prior to remediation, the work area shall be misted. Upon completion, the work area shall be HEPA vacuumed and then wet wiped with a detergent solution.
- 7.8. In Room G6, the work area shall be unoccupied, however, a containment and negative pressure enclosure system are not required. The water stained area below the contaminated gypsum board shall first be covered and sealed with two layers of 6-mil polyethylene sheeting. From above the ceiling, the visibly mold-contaminated area shall then be misted, sealed with sheeting, and be cut out and removed, followed by HEPA vacuuming and wet wiping with a detergent solution. The intent of this procedure is to seal the damaged portion, prior to removal, in order to eliminate the likelihood of airborne contamination. Upon completion, the remainder of the gypsum board, as defined in Paragraph 7.4, shall be removed.
- 7.9. In Room 215, all wallpaper shall be removed from the building exterior walls to inspect the concealed gypsum board for visible mold. Removal of wallpaper in this area shall be performed in order to evaluate conditions that may typically exist for those with wall coverings. If visible mold is found, a contract modification will be issued for removal and replacement of contaminated gypsum board. Restoration shall include preparation, priming, and painting of all walls. See SSOW for additional requirements.
- 7.10. In Room 217, beginning in the northeast corner, all wallpaper shall be removed from both sides of the column enclosure and from the north wall between the column enclosure, up to the edge of the accordion partition. Removal of wallpaper in this area shall be performed in order to evaluate conditions that may typically exist for those with wall coverings. If visible mold is found, a contract modification will be issued for removal and replacement of contaminated gypsum board. See SSOW for additional requirements.

- 7.11. In Rooms SJ6 and SJ8, floors shall be HEPA vacuumed and then wet wiped with a detergent solution. Metal walls shall be wet wiped with a detergent solution. Prior to vacuuming the floor in Room SJ8, the air intake opening shall be sealed with 2 layers of 6-mil polyethylene sheeting.
 - 7.12. In Room 217, and extending into stair 218, corridor 221, and electrical distribution room 235 (approximately 15 linear feet) and 3TS5 (approximately 12 linear feet), the water stained pipe insulation shall be removed and replaced.
 - 7.13. In Rooms BL2, 217, and 233, water stained ceiling tiles shall be removed and replaced.
 - 7.14. In Room 4TS5, the gypsum board walls enclosing the outside air ducts shall be wet wiped with a detergent solution to clean and remove the water marks.
 - 7.15. Place MCM and MCE in a fiber/cardboard type drum or 2-layers of 6-mil polyethylene disposal bags with contents clearly labeled. At completion of each phase, notify the Government of completion so that Government can perform a visual inspection of the work area. Allow negative pressure system to operate a minimum of two hours after the last clean-up effort.
 - 7.16. Upon approval of Government, remove barriers and disassemble regulated work area. Additional cleaning required in the work area because of the Government inspection, shall be performed by Contractor, at no additional cost to the Government.
- 8.0 AIR MONITORING AND INSPECTION.** The Government-retained industrial hygienist will determine any requirement for air monitoring, both during the remediation process and/or upon completion of the remediation process. Such area sampling will be conducted using Zefon filters and a high volume sampling pump. Procedural modifications to the decontamination procedures may be necessary at the discretion of the Government-retained industrial hygienist. The Government has the right to inspect the remediation work at times to be determined by the Government, but, at a minimum, once removal of contaminated materials is completed.
- 9.0 FINAL CLEARANCE.** Acceptance of work will be dependant upon visual inspection. The Contractor shall notify the Government when the microbiological removal is completed and a thorough visual inspection of the phase shall be conducted within twenty-four hours.
- 10.0 DISPOSAL.** All microbiological waste shall be disposed of in the FAA dumpster. Waste bags shall not be overloaded and shall be securely sealed and stored in the designated area until disposal. See SSOW for additional details and requirements.

ATTACHMENT 1

**Guidelines on Assessment and Remediation of
Fungi in Indoor Environments**

3

2

OST RECOMMENDATIONS TRACKING SHEET

November 4, 2008

| | OST Recommendations and FAA Responses | Due Date/Date Completed | Status |
|---|---|-------------------------|---|
| A | <p>OST Recommendation (ATCT): "Conduct a comprehensive inspection of the wall cavities on every floor of the air traffic control tower, making sure to inspect the wall cavity from the unoccupied room side of the elevator shaft."</p> <p><u>FAA Response:</u> The FAA will retain a Certified Industrial Hygienist experienced with mold and indoor air quality issues to complete the recommended action.</p> | December 31, 2008 | A 3 rd party contractor has been retained to perform the inspection. A start date is being scheduled for this month. The site survey should be completed in 7 days. |
| B | <p>OST Recommendation (ATCT): "Based on the comprehensive inspection, remove all visibly contaminated (molded and water damaged porous materials) from the air traffic control tower."</p> <p><u>FAA Response:</u> The FAA will develop and implement projects to remove molded and water damaged porous materials identified from the inspection. Action: Design and engineering will begin immediately upon completion of the inspection with contract work following as soon as possible.</p> | None | Based on a June 2008 facility inspection, a contract has been awarded to remediate the 4 th and 9 th floors, including other areas of the ATCT. If additional mold growth is found during the wall cavity inspections (see line "A"), P&R will work through EOSH Services regarding funding and planning remediation efforts. Remediation start dates in December and January are being considered. |

| | | | |
|-----------------|---|---|---|
| <p>C</p> | <p>OST Recommendation (ATCT): "Develop a mold remediation project communication plan for the facility to improve communication efforts between FAA management and union employees."</p> <p><u>FAA Response:</u> The FAA will develop a plan to improve communication.</p> | <p>October 1, 2008</p> <p>Completed Sep. 25, 2008</p> | <p>A plan was drafted by P&R and reviewed by local Terminal and Tech Ops managers. Comments were received and modifications were made to the plan. The plan is a "living document" and will be implemented for mold remediation and repair projects.</p> <p>Prior to the remediation (and as part of the communication plan), local management will develop and post a memorandum similar to that of the base building roof project. Refer to Section L for more information.</p> |
| <p>D</p> | <p>OST Recommendation (ATCT): "<i>Remove all unnecessary wallboard and carpeting from unoccupied areas of the air traffic control tower.</i>"</p> <p><u>FAA Response:</u> The FAA will assess which wallboard and carpeting is not needed in the unoccupied areas of the ATCT. A project will be developed to remove these items.</p> | <p>None</p> <p><i>(Refer to Recommendation B)</i></p> | <p>Incorporated into the project scope described in Recommendation B.</p> |

| | | | |
|---|---|---|--|
| E | <p>OST Recommendation (ATCT): <i>"Evaluate the fire rating of cement backer board and mold resistant/paperless wallboard."</i></p> <p><u>FAA Response:</u> The FAA will evaluate wallboard that needs to be replaced in the ATCT and attempt to substitute with fire-rated, mold-resistant products. When the wallboard is replaced, a gap will be left between the concrete floor slab and new wallboard to prevent wicking of moisture into the panel.</p> | <p>None</p> <p><i>(Refer to Recommendation B)</i></p> | <p>Incorporated into the project scope described in Recommendation B.</p> |
| F | <p>OST Recommendation (ATCT): <i>"Continue efforts to prevent moisture intrusion into the air traffic control tower and prevent condensation from forming."</i></p> <p><u>FAA Response:</u> The FAA will continue to prevent water intrusion and condensation issues in the ATCT. Comments and recommendations were submitted to the OST indicating that the corrective measures identified were completed and controlling the ATCT moisture issues. Further preventative measures such as gaps between the drywall and the concrete slab floors, removal of unnecessary wallboard and carpeting, and monitoring the environmental conditions (i.e., with sensors) in various areas will be pursued by the FAA.</p> | <p>None</p> <p><i>(Refer to Recommendation B)</i></p> | <p>Monitoring is on-going (See Recommendation G). Other items have been incorporated into the project scope described in Recommendation B.</p> |

| | | | |
|-----------------|---|--|---|
| <p>G</p> | <p>OST Recommendation (ATCT): <i>"Actively monitor moisture in the elevator shaft and unoccupied areas of the air traffic control tower and implement corrective actions as necessary."</i></p> <p><u>FAA Response:</u> The monitoring is currently in progress. To date, there are no indications of excessive moisture and/or humidity.</p> | <p>Ongoing</p> | <p>Data has been obtained for June and the last part of September 2008. No evidence of high moisture issues. Increased downloads will take place to ensure all data is captured. Local Tech Ops has been trying to contact the company to establish an internet connection and address other issues – so far the company has not responded. Tech Ops will continue to pursue.</p> |
| <p>H</p> | <p>OST Recommendation (ATCT): <i>"Review the policies at FAA's Detroit Air Traffic Control Tower to ensure that employees are encouraged to report work-related health and medical problems."</i></p> <p><u>FAA Response:</u> The agency will review such policies.</p> | <p>October 1, 2008</p> <p>Completed October 1, 2008; refer to the status column for additional information</p> | <p>Local managers have reviewed the FAA's policies. An all-hands meeting was held for local Tech Ops employees on Sep 3, 2008 where safety and work-related health issues were reviewed. Refer to Sections C and L for additional information.</p> |

| | | | |
|-----------------|--|--|---|
| <p>I</p> | <p>OST Recommendation (ATCT): <i>"Evaluate other FAA air traffic control towers for mold and moisture infiltration problems. The Detroit Metropolitan Airport air traffic control tower is of a Leo Daly design. FAA operates other Leo Daly designed towers of similar construction and characteristics. It is prudent for FAA to inspect these other towers to determine if similar mold and moisture problems exist at those facilities."</i></p> <p><u>FAA Response:</u> The DTW ATCT is a Leo Daly designed tower. The FAA will inspect Leo Daly designed towers throughout the country to determine if mold and moisture problems exist at these facilities.</p> | <p>December 31, 2008</p> | <p>An effort is being lead by EOSH Services to conduct these inspections. Currently 13 similar Leo-Daly type towers have been identified. MCI, SEA, and BUR have been inspected. DFW (2) and IAH will be inspected this week. Tower inspections have been scheduled for 5 sites; 2 sites are currently being scheduled.</p> |
| <p>J</p> | <p>Recommendation (Base Building): <i>"Replace the leaking base building roof."</i></p> <p><u>FAA Response:</u> A new roofing membrane will be installed by March 30, 2009.</p> | <p>March 30, 2009</p> | <p>The project is scheduled to start November 12, 2008. A pre-con meeting will be held on Nov 5th. The work will occur between 10 pm – 6am. Project activities will cease during the Thanksgiving moratorium, however continue afterwards. The reported date of completion is 12/19/08 (with the exception of the lightning protection).</p> |
| <p>K</p> | <p>OST Recommendation (Base Building): <i>"Continue to immediately remove and replace water damaged building materials as necessary."</i></p> <p><u>FAA Response:</u> The FAA will continue to remove and replace such items. When such incidents arise, an investigation shall be made to identify the moisture source and correct it.</p> | <p>Continuous until March 30, 2009</p> | <p>Efforts are ongoing.</p> |

| | | | |
|---|--|---|--|
| L | <p>OST Recommendation (Base Building): <i>"Develop a roof project communication plan for the facility to improve communication efforts between FAA management and union employees."</i></p> <p><u>FAA Response:</u> Local FAA management will develop a communication plan to educate employees about the roof project and the control efforts being implemented to ensure a safe working environment.</p> | <p>October 1, 2008</p> <p>Completed Sep. 25, 2008</p> | <p>A plan was drafted by P&R and reviewed by local Terminal and Tech Ops managers. Comments were received and modifications were made to the plan. The plan is a "living document" and will be implemented for mold remediation and repair projects.</p> <p>As part of the communication plan, local Tech Ops and Terminal managers developed and posted a memorandum on October 24, 2008 to notify their employees of the upcoming roof project and provide them with key information. Refer to the attached memorandum for additional information.</p> |
|---|--|---|--|

33

33

UNITED STATES DISTRICT COURT
FOR THE DISTRICT OF COLUMBIA
Civil Division

DENICOLE YOUNG and
VANESSA GHEE

Plaintiffs,

v.

WILLIAM F. BURTON and
LEWIS & TOMPKINS, P.C.

Defendants.

Civil Action No. 07cv0983 (ESH)

MEMORANDUM OPINION AND ORDER

Plaintiffs Denicole Young and Vanessa Ghee have sued William F. Burton and Lewis & Tompkins, P.C., for legal malpractice based on their failure to file a timely personal injury lawsuit. The original lawsuit would have sought recovery for damages suffered by plaintiffs as a result of exposure to toxic mold while residing at the Stanton Glen Apartments. In order to succeed on their legal malpractice claim, plaintiffs must show that their attorneys' alleged negligence adversely affected their ability to benefit from an otherwise meritorious claim. *See Niosi v. Aiello*, 69 A.2d 57, 60 (D.C. 1949). To make their case, plaintiffs rely on the testimony of Dr. Ritchie Shoemaker as to the cause, nature, and extent of their injuries. Defendants have moved to exclude Dr. Shoemaker's testimony, arguing that his opinions are not based on a reliable methodology, and that regardless, Dr. Shoemaker did not follow his own methodology with respect to plaintiffs.

Based on the record herein, including the testimony presented at a *Daubert* hearing, the Court concludes that Dr. Ritchie Shoemaker's diagnosis of plaintiffs, as well as his opinions

relating to general and specific causation, are not sufficiently grounded in scientifically valid principles and methods to satisfy *Daubert*. Therefore, defendants' motion will be granted.

BACKGROUND

I. PLAINTIFFS

Plaintiffs moved into Apartment 2A at 3064 Stanton Road, S.E. on August 19, 2002. (Compl. ¶ 8.) They resided there for approximately thirty-four days, during which time plaintiffs contend they could smell noxious fumes from raw sewage. (Pls.' Opp'n at 5; Pls.' Ex. 5 [Ghee Dep.] at 252.) In early September 2002, while investigating the smell, plaintiffs climbed through a window of the adjacent apartment, Apartment 1A, and took photographs of the extensive visible mold growth in this vacant apartment. (Defs.' Mot. at 2; Defs.' Ex. 3 [Young Dep.] at 175-78; Pls.' Ex. 7 [Photographs].) Although plaintiffs are not sure exactly how long they spent in Apartment 1A, they estimate it was no longer than one or two minutes. (Defs.' Mot. at 2; Defs.' Ex. 3 at 178.) There was no documentation of any visible mold growth in plaintiffs' apartment (Daubert Hr'g Tr. ["Tr."] at 76:2-5, June 16, 2008), and plaintiffs do not believe the two apartments shared a common air source. (Defs.' Mot. at 2; Defs.' Ex. 1 [Ghee Dep.] at 452). On September 23, 2002, plaintiffs signed a lease agreement for a different unit in the apartment complex and immediately moved into the new apartment. (Pls.' Opp'n at 5; Defs.' Ex. 2 [Lease Agreement].)

Both plaintiffs submitted extensive medical records to document the health problems that they attribute to their mold exposure. Approximately two weeks after moving into the apartment, Vanessa Ghee visited George Washington University Hospital ("GWUH") on September 6, 2002. (Defs.' Ex. 4 [Ghee Medical Records] at 19.) She complained of a productive cough that

had lasted three weeks and indicated that she had experienced a similar cough three months prior to that visit. (*Id.*) She was diagnosed with viral bronchitis and was instructed to use a humidifier at home and to quit smoking. (*Id.* at 22.) When she returned to GWUH a week later on September 13, 2002, she was given Claritin and again instructed to stop smoking. (*Id.* at 27.) After moving out of the apartment, Ghee required medical care only intermittently. (Pls.' Ex. 11 [Ghee Medical Records].)

Denicole Young's medical records indicate significant medical problems prior to moving into the apartment. She was seen for bronchitis and sinusitis as early as December 10, 1996. (Defs.' Ex. 5 [Young Medical Records] at 642.) She was seen again for sinus congestion and cough on October 21, 1997 (*id.* at 632) and July 29, 1998 (*id.* at 609), and she complained of chronic fatigue on January 9, 1998 (*id.* at 611) and March 10, 2000. (*Id.* at 602). She was also seen many times during those years for complications from her sickle cell trait. Young went to GWUH with Ghee on September 6 and 13, 2002, and was also diagnosed with bronchitis, prescribed Claritin, and told to use her inhaler. (Defs.' Ex. 5 at 656-59.) Young's medical records from the September 13 visit indicate a past history of asthma (*id.*), although it is unclear exactly when she first received that diagnosis. In the months after moving out of the apartment, Young required a few medical visits for minor problems but was hospitalized for asthma exacerbation and pneumonia on April 15, 2003. She required intubation on three separate occasions during that hospital stay. (Pls.' Ex. 12 [Young Medical Records] at 983-94.) She had regular doctors' visits over the next two years relating to asthma, sore throats, coughing, allergic reactions, and swelling in her extremities. (*Id.* at 157-52, 150-48, 145-38, 134-33, 131-27, 123-

22, 118-16, 84-80, 75-74, 971-82, 924-35, 912-23, 899-911, 1000-22, 1055-70, 1086-94, 1308-13, 1326-30, 1332-38.)

II. DR. SHOEMAKER

Dr. Shoemaker received his doctorate from Duke University. (Pls.' Ex. 15 [Shoemaker CV] at 1.) He is currently a member of the American Medical Association, the American Society for Microbiology, the American Society of Tropical Medicine and Hygiene, the International Association for Chronic Fatigue Syndrome, and the Maryland Medical Chirurgical Association. (*Id.*) He has practiced as a licensed medical doctor in Pocomoke, Maryland since 1980 (Pls.' Ex. 14 [Shoemaker Aff.] ¶ 3) and has been the treating physician for over 4,700 patients whom he has diagnosed with ailments caused by exposure to water-damaged buildings. (*Id.* ¶ 5). He has also authored numerous publications and books, including *Mold Warriors*, which was published in 2005. (*Id.*)

A. Methodology

Dr. Shoemaker described his methodology for diagnosing cases of mold illness¹ as follows. He begins by following standard diagnostic procedures with new patients: first, he takes the patient's history, and second, he performs an examination of the area that is the subject of the patient's complaint. (Pls.' Ex. 14 ¶¶ 13-14.) Then, depending on the circumstances of the illness and if there is a temporal relationship that suggests that the patient was in a location where he may have been exposed to a possible environmental contaminant, Dr. Shoemaker will turn to his own differential diagnostic procedure for mold illness. (*Id.* ¶ 15.)

¹ "Mold illness" is a term coined by Dr. Shoemaker which he uses to describe an "acute and/or chronic, biotoxin associated illness caused by exposure to indoor environment of water-damaged buildings with resident toxigenic organisms." (Pls.' Ex. 55 [Shoemaker Report] at 6.)

That procedure involves a two-tiered analysis. (*Id.* ¶ 17.) To satisfy the first tier, all three of the following factors must be met: “(1) the potential for exposure; (2) the presence of a distinctive group of symptoms; and (3) the absence of confounding diagnoses and exposures.” (*Id.* ¶ 18.) According to Dr. Shoemaker, the second tier acts as confirmation of the diagnosis arrived at in the first tier and requires that three of the following six factors be met: (1) HLA DR showing susceptibility to mold illness; (2) reduced levels of melanocyte stimulating hormone (MSH); (3) elevated levels of matrix metalloproteinase-9 (MMP9); (4) deficits in visual contrast sensitivity (VCS); (5) dysregulation of ACTH and cortisol; and (6) dysregulation of ADH and osmolality. (Defs.’ Mot. at 6-7.) HLA DR refers to certain genes which Dr. Shoemaker believes are associated with a patient’s susceptibility to mold illness. He claims there are certain versions of those genes, or genotypes, which render a patient more likely to have adverse health consequences from exposure to damp indoor environments. (Pls.’ Ex. 14 ¶ 21.) VCS is a test of a patient’s ability to detect certain visual patterns, which, in turn, is an indicator of neurologic functioning. (*Id.* ¶ 26.) The other four tests look at levels of certain hormones and enzymes in the blood which Dr. Shoemaker believes are altered by exposure to a biotoxin. (*Id.* ¶¶ 18-19.) Dr. Shoemaker refers to those hormones and enzymes as “biomarkers.”

If a patient meets both tiers of this case definition, Dr. Shoemaker typically recommends treatment with Cholestyramine (“CSM”), a cholesterol-lowering drug which binds molecules in the intestinal track and prevents them from being absorbed into the body. (Defs.’ Ex. 7 [Dr. S. Michael Phillips’ Report] at 16.) Dr. Shoemaker uses CSM on an off-label basis, meaning he uses it for a purpose other than that for which it has been approved by the FDA. (*Id.* at 17.)

Dr. Shoemaker has published three peer-reviewed publications regarding mold illness. (Pls.' Ex. 16 [Shoemaker Mold Publications].) The first of these papers established the case definition for biotoxin illness by confirming a set of diagnostic criteria that was present in nearly all of the "cases" of biotoxin illness, and in virtually none of the "control" subjects. Ritchie C. Shoemaker, et al., *Sick Building Syndrome in Water Damaged Buildings: Generalization of the Chronic Biotoxin-Associated Illness Paradigm to Indoor Toxicogenic Fungi*, in *BIOAEROSOLS, FUNGI, BACTERIA, MYCOTOXINS AND HUMAN HEALTH: PATHOPHYSIOLOGY, CLINICAL EFFECTS, EXPOSURE ASSESSMENT, PREVENTION AND CONTROL IN INDOOR ENVIRONMENTS AND WORK*, 66-77 (Eckhardt Johanning, ed., 2005). The second paper looked more closely at the changes in levels of certain biomarkers in biotoxin illness patients in response to treatment and re-exposure. Ritchie C. Shoemaker & Dennis E. House, *A Time-Series Study of Sick Building Syndrome: Chronic, Biotoxin-Associated Illness from Exposure to Water-Damaged Buildings*, 27(1) *NEUROTOXICOLOGY AND TERATOLOGY* 29 (2005). The third paper consisted of a double-blind, placebo-controlled study of the use of CSM to treat biotoxin illness and also reaffirmed his case definition. Ritchie C. Shoemaker & Dennis E. House, *Sick Building Syndrome (SBS) and Exposure to Water-Damaged Buildings: Time Series Study, Clinical Trial and Mechanisms*, 28(5) *NEUROTOXICOLOGY AND TERATOLOGY* 573 (2006). This third study was extremely limited; it looked at twenty-six subjects, only thirteen of whom participated in the placebo-controlled trial, and each subject served as his own control. *Id.* at 575-76.

In his studies, Dr. Shoemaker uses a five-step, repetitive exposure protocol to establish the cause of his subjects' illnesses. First, the patient is evaluated under the two tiers explained above and then diagnosed with mold illness. Second, the patient is treated with CSM and tested

to ensure that the biomarker levels have returned to normal. Third, the patient stops CSM treatment and stays away from the suspected mold environment to see if the illness returns when exposed to the variety of biotoxins which are ubiquitous in everyday life. If the patient's biomarker levels remain normal, this means that other exposures are ruled out as the source of the symptoms. Fourth, the patient then returns to the mold environment for no more than three days, and finally, the patient is re-tested to obtain final biomarker readings after having re-acquired the illness. (Pls.' Ex. 55 at 31-32.) By demonstrating that the abnormal levels of biomarkers are associated with the patient's presence in the suspected mold environment, Dr. Shoemaker claims that the illness was caused by exposure to that building.

B. Diagnosis of Plaintiffs

Plaintiffs visited Dr. Shoemaker on September 11, 2007, to obtain his expert opinion regarding the etiology of their symptoms. (Pls.' Ex. 55 at 1.) He spent roughly two hours with each plaintiff, during which time he took their medical histories and performed physical exams. (Pls.' Ex. 55 at 14.) He also performed a VCS test, pulmonary function, electrocardiogram, and pulse oximetry.² (*Id.*) At that time, he ordered that laboratory tests be conducted on plaintiffs' blood samples to determine plaintiffs' levels of the Tier 2 biomarkers. (*Id.*) However, even before he received the results of these tests, and thus with no information as to whether plaintiffs met the second tier of his diagnostic criteria, he concluded that "[b]oth Ms. Young and Ms. Ghee acquired a typical biotoxin-associated illness following exposure and re-exposure to the indoor

² Dr. Shoemaker requests that his patients complete a number of additional tests that he finds useful in making his diagnosis, all of which plaintiffs chose not to complete. These include an MR spectroscopy, which provides information about cognitive impairment; a pulmonary stress test, which determines O₂ max; and a stress echo, which measures pressure in the pulmonary artery circuit. (Tr. at 247:18-249:9.)

air environment of their townhouse at Apt 2A 3064 Stanton Rd SE, Washington, DC.” (*Id.* at 1.) The September 2007 visit, which occurred five years after plaintiffs moved out of Apartment 2A, was the only time Dr. Shoemaker examined the plaintiffs. At some point after that examination, Dr. Shoemaker received the results of plaintiffs’ blood tests, which he believes confirms his initial diagnosis. According to Dr. Shoemaker, Young had four of six abnormal blood test results, and Ghee had three of six (three being the minimum required to meet the second tier). (Pls.’ Ex. 14 ¶¶ 103-04.) Both plaintiffs had mold susceptible HLA DR genotypes, and both had deficits in their VCS scores, although Dr. Shoemaker was unable to provide plaintiffs’ actual results for the VCS test. (*Id.*; Tr. at 157:5.) In addition to those tests, Young’s tests revealed MSH of 12 pg/ml and MMP9 of 565, and Ghee’s test results revealed MSH of 18 pg/ml, all of which Dr. Shoemaker classifies as abnormal. (Pls.’ Ex. 14 ¶¶ 103-04.)

Dr. Shoemaker did not perform his five-step protocol on plaintiffs, and indeed could not possibly have done so, as he first met them long after they left the suspected mold environment. Nor was he able to base his causation opinion on the plaintiffs’ response to treatment, for both plaintiffs chose not to take the CSM that he had prescribed for them. (Tr. at 19:20-23.) However, he is of the opinion that now that he has proven the research model for mold illness in his 2006 publication, it is no longer necessary to follow the five-step protocol with new patients, because causation necessarily follows from his diagnosis. (Pls.’ Ex. 14 ¶ 93.)

III. PROCEDURAL POSTURE

At the conclusion of discovery, defendants moved for a *Daubert* hearing, relying on the affidavits of two experts. According to their expert toxicologist, Dr. Scott Phillips, since there was no evidence as to the exact substance plaintiffs were exposed to or the level at which they

were exposed, formal toxicological causation analysis could not be performed. (Defs.' Ex. 6 [Dr. Scott Phillips' Report] at 23-24.) In addition, the tests Dr. Shoemaker uses to reach his diagnosis are experimental and "not generally accepted in the toxicology community." (*Id.* at 28-29.) Dr. Phillips explained the traditional causation analysis, comprised of the nine "Hill Criteria" that are necessary to establish a causal relationship between two things,³ and using these criteria, he opined that "there is no support for a causal association between the dark material on the adjacent apartment walls and the Plaintiffs['] health complaints." (*Id.* at 25-26.) Defendants' expert immunologist, Dr. S. Michael Phillips, walked through each of the Hill Criteria and explained how the facts of this case cannot support a finding of causation. (Defs.' Ex. 7 [Dr. S. Michael Phillips' Report] at 10-14.) He also faulted Dr. Shoemaker's conclusions on the grounds that "[b]iotoxins do not cause the spectrum of disease shown by Denicole and Vanessa"; that none of the laboratory criteria Dr. Shoemaker uses to arrive at his diagnosis has been "causally associated with specific biotoxin associated human illness"; and that "the medical community does not recognize" biotoxin-associated illness. (*Id.* at 15-17.) Also, according to Dr. Phillips, no actual exposure to mold has been demonstrated; neither plaintiff has any symptoms or test results that could be caused by biotoxins; and "allergies and infections may be plausible explanations of Denicole's major respiratory exacerbation" on April 15, 2003. (*Id.* at 17-18.)

In their opposition, plaintiffs argue that defendants' criticisms only amount to an attack on Dr. Shoemaker's conclusions, not his methodology, and therefore, defendants cannot prevail even if Dr. Shoemaker "draws *conclusions* from test methods and lab tests established for other

³ The nine Hill Criteria are: 1) strength; 2) consistency; 3) specificity; 4) temporality; 5) biological gradient; 6) plausibility; 7) coherence; 8) experiment; and 9) analogy. (Defs.' Ex. 6 at 25.)

purposes, and applies them to a different use.” (Pls.’ Opp’n at 27.) In making this argument, plaintiffs rely on Dr. Shoemaker’s affidavit, in which he elaborated on his methodology and explained that he uses standard differential diagnostic procedures which are widely used and accepted in the scientific community. (Pls.’ Ex. 14 ¶¶ 11-16.) Plaintiffs also submitted Dr. Shoemaker’s peer-reviewed publications on “mold illness,” along with numerous scientific papers explaining the human health effects of mold, in order to rebut defendants’ contention that Dr. Shoemaker’s testimony is not based on a scientifically valid methodology. (Pls.’ Exs. 16-33.)

The Court granted a *Daubert* hearing, and both parties submitted direct testimony in the form of affidavits from their experts in advance of the hearing. During the hearing, held on June 16, 2008, Dr. Shoemaker was subjected to cross-examination, followed by the testimony of Dr. S. Michael Phillips. Based on this testimony, as well as the parties’ prior submissions, the Court makes the following findings of fact and conclusions of law.

ANALYSIS

I. GOVERNING LEGAL STANDARDS

The admissibility of expert testimony in federal courts is governed by Federal Rule of Evidence 702, which provides:

If scientific, technical, or other specialized knowledge will assist the trier of fact to understand the evidence or to determine a fact in issue, a witness qualified as an expert . . . may testify thereto in the form of an opinion or otherwise.

As explained by the Supreme Court, under Rule 702, “the trial judge must determine at the outset . . . whether the expert is proposing to testify to (1) scientific knowledge that (2) will assist the trier of fact to understand or determine a fact in issue.” *Daubert v. Merrell Dow Pharms., Inc.*,

509 U.S. 579, 592 (1993). The first prong of the analysis “establishes a standard of evidentiary reliability,” *id.* at 590, while the second prong “goes primarily to relevance.” *Id.* at 591.

Testimony as to the nature, cause, and extent of plaintiffs’ symptoms is clearly relevant to the final determination of liability and damages. Furthermore, such testimony involves medical and scientific matters which are beyond the ken of the average juror. Thus, the only inquiry is whether Dr. Shoemaker’s testimony meets the standard for evidentiary reliability under the first prong of the *Daubert* analysis.

In performing its “gatekeeping” role, “the district court must focus ‘solely on principles and methodology, not on the conclusions that they generate.’” *Ambrosini v. Labarraque*, 101 F.3d 129, 133 (D.C. Cir. 1996) (quoting *Daubert*, 509 U.S. at 595). In so doing, “the district court must engage in ‘a preliminary assessment of whether the reasoning or methodology underlying the testimony is scientifically valid and of whether that reasoning or methodology properly can be applied to the facts in issue.’” *Id.* at 133 (quoting *Daubert*, 509 U.S. at 592-93). The Supreme Court suggested several factors to be used in making that assessment: “(1) whether the theory or technique can be (or has been) tested; (2) whether the theory or technique has been subject to peer review and publication; (3) the known or potential rate of error of the methodology; and (4) the general acceptance of the methodology.” *Raynor v. Merrell Pharms. Inc.*, 104 F.3d 1371, 1375 (D.C. Cir. 1997). That list of factors “is ‘flexible’ and . . . neither necessarily nor exclusively applies to all experts or in every case.” *Kumho Tire Co. v. Carmichael*, 526 U.S. 137, 141 (1999). Nor is it a “definitive checklist” or test. *Daubert*, 509 U.S. at 593. The burden is on the proponent of the evidence to show that by a preponderance of

the evidence the opinions they seek to present are reliable. *Meister v. Med. Eng'g Corp.*, 267 F.3d 1123, 1127 n.9 (D.C. Cir. 2001).

II. APPLICATION OF *DAUBERT* TO TOXIC TORT AND MOLD CASES

Courts throughout the country have varied widely with respect to the level of certainty they require with respect to the issue of causation in toxic tort cases generally, and in mold cases specifically. See Jeffrey J. Hayward, *The Same Mold Story?: What Toxic Mold is Teaching us about Causation in Toxic Tort Litigation*, 83 N.C. L. Rev. 518, 536-38 (2005). One common method of attempting to demonstrate causation is showing a temporal relationship between exposure to a toxin and subsequent adverse health effects. While the circumstances of the exposure and the timing of the illness may be so compelling as to render further evidence of causation unnecessary, temporal association between exposure and illness, without more, is generally insufficient to establish causation. For example, the Fourth Circuit allowed testimony that relied heavily on temporality where the symptoms began shortly after the plaintiff started working with a toxic chemical, and where the plaintiff's symptoms increased or decreased depending on whether the plaintiff was at work or away from the job site. *Westberry v. Gislaved Gummi AB*, 178 F.3d 257, 265 (4th Cir. 1999). However, *Moore v. Ashland Chem.*, 151 F.3d 269 (5th Cir. 1998), represents a more traditional approach, in which the Fifth Circuit concluded that “[i]n the absence of an established scientific connection between exposure and illness, . . . the temporal connection between exposure to chemicals and an onset of symptoms, standing alone, is entitled to little weight in determining causation.” *Id.* at 278. A district court judge in the Eastern District of Virginia applied that same logic to a mold case when he found that “[a]n

opinion based primarily, if not solely, on temporal proximity does not meet *Daubert* standards.”
Roche v. Lincoln Property Co., 278 F. Supp. 2d 744, 764 (E.D. Va. 2003).

The most widely-used method of demonstrating causation in toxic tort cases is to present scientifically-accepted information about the dose-response curve for the toxin which confirms that the toxin can cause the health effects experienced by the plaintiff at the dosage plaintiff was exposed to. Indeed, “[s]cientific knowledge of the harmful level of exposure to a chemical, plus knowledge that the plaintiff was exposed to such quantities, are minimal facts necessary to sustain the plaintiff’s burden in a toxic tort case.” *Mitchell v. GenCorp, Inc.*, 165 F.3d 778, 781 (10th Cir. 1999) (quoting *Wright v. Willamette Indus., Inc.*, 91 F.3d 1105, 1106 (8th Cir. 1996)). Accordingly, the Fifth Circuit in *Moore* found an expert’s testimony unreliable because he had no information about the level of plaintiff’s exposure to the chemical solution and thus could not adequately support an assertion that the levels plaintiff was exposed to were sufficient to cause adverse health effects. 151 F.3d at 278.

In a similar vein, the court in *Cavallo v. Star Enterprise*, 892 F. Supp. 756 (E.D. Va. 1995), adopted the three-step methodology for toxicologists endorsed by the World Health Organization, which involves 1) evaluating the chemicals to which the individual may have been exposed and the concentrations of those chemicals in the air the individual breathed; 2) evaluating the level of exposure necessary to produce adverse health effects, according to the published scientific literature; and 3) combining the first two evaluations to estimate the likelihood that the individual actually suffered any of the harmful effects of the chemical in question. *Id.* at 764. That same court later required that any expert giving testimony as to

toxicology, even if not a toxicologist himself, must apply that same methodology in order to ensure reliability. *Roche*, 278 F. Supp. 2d at 754.⁴

Another issue that has affected the causation inquiry in many of the mold cases to date is whether the plaintiff had a proven allergy to the molds to which he or she was exposed. *See, e.g., Roche*, 278 F. Supp. 2d at 751 (finding an expert's opinion that mold was the cause of an illness unreliable because the plaintiff was not allergic to the molds found in his apartment); *Flores v. Allstate Texas Lloyd's Co.*, 229 F. Supp. 2d 697, 702 (S.D. Tex. 2002) (finding testimony inadmissible in part because the medical expert had not based "his testimony on the results of any testing done to determine whether Plaintiffs [were] allergic to any specific type of mold found in their home"). In contrast, Dr. Shoemaker's theory of mold illness is based on the belief that patients have innate immune responses to mold, rather than acquired immune responses (*i.e.*, allergies), and as such, his methodology necessarily deviates from causation inquiries in prior mold cases. (Pls.' Ex. 14 ¶ 25.)

Given the unique nature of his testimony, it is hardly surprising that Dr. Shoemaker has been challenged in numerous jurisdictions throughout the country. Plaintiffs assert that Dr. Shoemaker's testimony has been challenged under *Daubert*, *Frye*, and other standards over twenty times, and they claim that he has been permitted to testify "[t]he overwhelming majority

⁴ To be sure, not every court has required the same level of specificity with regard to exposure level. The *Westberry* court, for example, considered it sufficient that plaintiffs had shown both that inhalation of high levels of talc undisputedly could cause irritation of mucous membranes, and that plaintiff had been exposed to substantial levels of talc. 178 F.3d at 264. Similarly, the Supreme Court of Delaware affirmed the admission of expert testimony about mold-related injuries despite a lack of environmental testing during certain years that the plaintiff resided in the contaminated environment. *New Haverford P'ship v. Stroot*, 772 A.2d 792, 799 (Del. 2001). However, even in those and other similar cases, there has always been at a minimum confirmation of *some* exposure to mold or the toxin in question.

of the time.” (Pls.’ Opp’n at 32.) However, they have submitted exhibits documenting only five such cases, none of which was decided under *Daubert*. (Pls.’ Exs. 47, 48, 49, 53, 54.)

Furthermore, in only one of those cases did the court issue an opinion, and in that opinion, only two paragraphs were devoted to Dr. Shoemaker. *Colaianni v. Stuart Frankel Dev. Corp., et al.*, No. 2003 051245 NO, at 3-4 (Mich. Cir. Ct., Oakland County, May 29, 2007) (opinion and order granting in part and denying in part motion in limine). As a result, this Court cannot decipher the scope of Dr. Shoemaker’s proffered testimony in those cases where he has been permitted to testify, nor can the Court evaluate the reasoning of those decisions. Furthermore, Dr. Shoemaker admits that this case is different from any other case where he has testified, because he has been unable to take any of the steps of his repetitive-exposure protocol, including treatment, which he relies on in determining causation. (Tr. at 105:23-25.) As such, none of the cases where Dr. Shoemaker’s testimony was admitted is particularly informative.

Furthermore, his testimony has been excluded in a number of jurisdictions, including Virginia, Florida, and Alabama, as well as several cases that are remarkably similar to this one. (See Defs.’ Mot. at 22-24.) A D.C. Superior Court judge excluded Dr. Shoemaker’s testimony because neither his theory on the effects of indoor mold exposure nor his methodology in diagnosing the plaintiffs with chronic biotoxin-associated illness [“CBAI”]⁵ was generally accepted within the scientific community. *Wright v. Fort Lincoln Realty Co., et al.*, No. 03ca4555, at 2-4 (D.C. Sup. Ct. Oct. 15, 2007) (order granting motion in limine). The judge found that “Dr. Shoemaker failed to confirm that the patients were actually exposed to mold in

⁵ Chronic biotoxin-associated illness is the name Dr. Shoemaker used for plaintiffs’ condition before switching to “mold illness.” (Tr. at 28:5-11.)

their indoor environments”; the general scientific community does not recognize Dr. Shoemaker’s use of CSM to treat CBAI; and “some of the tests used by Dr. Shoemaker to diagnose the Wrights with CBAI are not generally used by or generally accepted by doctors to diagnose patients with mold-related illnesses.” *Id.* at 5-6.

Even more recently, in May 2008, the Ohio Court of Appeals affirmed the trial court’s grant of a motion to exclude Dr. Shoemaker’s testimony. *Herzner v. Fischer Attached Homes, Ltd.*, No. CA2007-08-090, 2008 WL 2004473, at *3 (Ohio Ct. App. May 12, 2008). Importantly, Ohio’s evidentiary standard for admissibility of expert testimony incorporates the teaching of *Daubert*. *Id.* at *1. Applying *Daubert*’s standard, the trial court offered a host of reasons for excluding Dr. Shoemaker’s testimony. First, there was insufficient evidence demonstrating actual exposure to mold toxins. The environmental tests conducted on the apartment were completed three months after the plaintiff had moved out of the apartment, and they failed to demonstrate that the mold spores present in the apartment at that time were actually producing toxic byproducts. *Herzner v. Fischer Attached Homes, Ltd.*, No. 2004CVC00564, at 11-12 (Ct. of Common Pleas, Clermont County, Ohio, May 1, 2007). The trial court also found that there had been “inadequate testing to demonstrate a causal connection between exposure to mycotoxins and human health effects” and noted the “lack of peer-reviewed medical literature on ‘mold illness’ and its causes as defined by Dr. Shoemaker.” *Id.* at 13. Furthermore, the court considered Dr. Shoemaker’s differential diagnosis process to be unreliable, largely because his “use and interpretation of the laboratory results . . . is not widely recognized in the medical community.” *Id.* at 19. On appeal, the appellate court concluded that “[t]he trial court’s

thorough and well-reasoned analysis exposed numerous faults in the principles and methods utilized by Dr. Shoemaker to draw his conclusions.” *Herzner*, 2008 WL 2004473, at *3.

For many of the same reasons cited by the courts in Ohio and D.C., as well as those set forth herein, this Court finds that Dr. Shoemaker’s testimony as to the diagnosis of mold illness, general and specific causation, and the nature and extent of plaintiffs’ injuries does not satisfy *Daubert*.

III. DIAGNOSIS

A. “Mold Illness” or “CBAI”

Differential diagnosis is a process by which a physician takes a patient’s history, compiles all possible explanations for the symptoms complained of, and then rules out each explanation until only the most likely diagnosis remains. (Defs.’ Ex. 19 [Dr. Scott Phillips Aff.] ¶¶ 17-18.) Dr. Shoemaker asserts that he conducted a differential diagnosis, and in the case of both plaintiffs, he determined that “mold illness” was the only possible explanation for their complaints. However, in order for his diagnostic process to be considered scientifically valid, the diagnosis must be one that is recognized by the scientific community.

Based on Dr. Shoemaker’s testimony, the Court cannot conclude that “mold illness” is a generally-accepted illness in the medical community. First, he admits that no one outside his practice group has published any peer-reviewed articles on “mold illness,” as defined by his two-tiered case definition. (Defs.’ Ex. 9 [Shoemaker Dep.] at 51:18-22.) Second, he agrees that CBAI is not generally accepted by the medical community:

Q: And CBAI, can we say that that’s not a generally-accepted diagnosis?

A: No argument about that.

(*Id.* at 196:13-15.)⁶ Third, Dr. Shoemaker concedes that there is no formal code in the International Classification of Diseases (ICD-9-CM) for CBAI (*id.* at 196:16-21), and that his case definition for “mold illness” is not used in any medical school in the country. (Tr. 151:16-19.) And lastly, the tests that Dr. Shoemaker uses are not intended to test for “mold illness.” (Defs.’ Ex. 19 ¶ 14.) Therefore, as found in other recent cases, “mold illness,” as defined by Dr. Shoemaker, is not a medically-accepted diagnosis. As such, any differential diagnosis which results in the conclusion that “mold illness” is the most likely explanation for the patients’ illnesses is, by definition, unreliable.

B. Case Definition

1. Tier One

a. Plaintiffs’ Potential for Exposure

Perhaps more importantly, even if “mold illness” were an accepted diagnosis, Dr. Shoemaker has not shown that plaintiffs meet his case definition. In the first tier of Dr. Shoemaker’s case definition, the patient must have the potential for exposure to toxigenic organisms. However, as the court in *Herzner* pointed out, “[c]learly, a person cannot be made ill by mold toxins to which she has not actually been exposed.” *Herzner*, No. 2004CVC00564, at 10. No environmental tests were conducted in plaintiffs’ apartment to provide actual proof that plaintiffs did, in fact, inhale toxic substances when they resided there. Despite this absence of proof, Dr. Shoemaker attempts to show that plaintiffs had the requisite exposure in two ways, neither of which is convincing.

⁶ Similarly, in a *Frye* hearing held before the D.C. Superior Court on September 27, 2007, Dr. Shoemaker acknowledged the lack of consensus within the scientific community regarding the legitimacy of CBAI. *Wright*, No. 03ca4555, at 3.

First, Dr. Shoemaker believes that his case definition allows him to use the diagnosis of the disease as evidence of actual exposure. (See Pls.' Ex. 14 ¶¶ 18-19.) The flaw in his logic was succinctly explained by defense expert Dr. Scott Phillips:

[T]he alleged symptoms and ailments are used in an attempt to explain that sufficient exposure and dose have occurred. Then, it is argued that exposure has now been shown to be sufficient, and this "proof of exposure" becomes a basis for explaining the cause of the symptoms and ailments. In short, the symptoms fundamentally become the basis for explaining themselves. Such circular reasoning is not scientifically or medically acceptable.

(Defs.' Ex. 19 ¶ 23.) In order for his methodology to be considered scientifically valid and reliable, Dr. Shoemaker must show *actual* exposure to toxins, and not mere *potential* for exposure.

Dr. Shoemaker's second argument is that because plaintiffs were exposed to a water-damaged building, it is "implausible" that plaintiffs would not have had any actual exposure to toxins, and so, in effect, potential for exposure is evidence of actual exposure. (Tr. at 60:23-61:5.) As evidence of exposure to a water-damaged building, Dr. Shoemaker relies on: 1) musty smells in plaintiffs' apartment; 2) visible mold growth in the neighboring apartment; and 3) a Department of Health letter pointing to musty odors in the basement of plaintiffs' building and visible mold growth on the walls of the utility room. (Tr. at 56:10-13, 57:17-25.) What he does *not* point to, because he cannot, is any sort of environmental test showing the presence of mycotoxins or other toxins in the air plaintiffs breathed while they resided in the apartment. However, Dr. Shoemaker considers it unnecessary to have any test results confirming what substances were present in either apartment, and whether those substances were actually producing toxins at the time plaintiffs resided there. With respect to the photographs of the

microbial growth in Apartment 1A, Dr. Shoemaker opined that “if you find such microbial growth, it is implausible that they would not be making toxigenic substances at some time,” and thus, “the argument cannot be sustained that you must test for mycotoxins alone to show illness.” (*Id.* at 60:23-61:5.)⁷ He also considers it unnecessary to know the level of toxic substances to which plaintiffs were exposed because dose response is an invalid concept when discussing genetic susceptibility. He claims that even minimal exposure to a biotoxin for someone with a genetic susceptibility to mold illness can cause a large array of severe symptoms. (Pls.’ Ex. 14 ¶ 131.) This reasoning permits Dr. Shoemaker to attribute any number of symptoms to a patient with a genetic susceptibility to mold who was exposed to a water-damaged building, without any information as to the type or amount of toxins she was exposed to.

These arguments are not scientifically valid. First, as explained in Section III(B)(2), the idea of a genetic susceptibility to mold induced illness is unsupported by the scientific literature. Dr. Shoemaker therefore cannot disregard the need for information as to dosage. Second, his methodology contravenes standard toxicology. As explained by defendants’ toxicology expert, Dr. Scott Phillips, the more traditional, generally-accepted theory of causation involves the presence of a substance, the opportunity for contact between the patient and that substance, a known dosage of the substance, and an illness consistent with the substance at that dosage.

⁷ Importantly, that statement was made in reference to the visible growth in Apartment 1A. No such visible growth was documented in plaintiffs’ apartment, Apartment 2A (Tr. at 61:6-15), and there is no indication that the two apartments shared a common air source. The apartment complex cannot be held liable for any injuries plaintiffs may have sustained while in Apartment 1A, as plaintiffs were trespassers at that time. *Firfer v. United States*, 208 F.2d 524, 528 (D.C. Cir. 1954) (“[A trespasser] must take the premises as he finds them, and cannot hold the owner to liability based upon negligence in failing to make the premises safe.”). It is therefore significant that Dr. Shoemaker admits he cannot quantify what effects going into 1A may have had on plaintiffs, as opposed to just living in the adjacent apartment. (Tr. at 242:2-5.)

(Defs.' Ex. 6 at 17.) Because scientific studies do not yet exist that demonstrate what levels of toxins produced by water-damaged buildings are harmful to humans, and what illnesses they cause, that methodology cannot currently be applied to mold. The Institute of Medicine, in a paper cited by Dr. Shoemaker, concludes that the doses of toxins found in water-damaged buildings necessary to produce adverse health effects in humans have not yet been determined. (Pls.' Ex. 20 [Damp Indoor Spaces (IOM)] at 7.) Similarly, the New York City Department of Health issued a report entitled *Guidelines on Assessment and Remediation of Fungi in Indoor Environments*, which states that "it is not possible to determine 'safe' or 'unsafe' levels of exposure" to fungi. (Pls.' Ex. 22 [NYC Guidelines].) Without that information, Dr. Shoemaker's testimony about the health effects of any such "exposure" cannot possibly be anything other than conjecture. Even if such knowledge existed, Dr. Shoemaker would still be unable to offer any concrete evidence as to what substances existed at what levels. Thus, there is no basis upon which to conclude that plaintiffs' exposures were sufficient to account for the variety of symptoms they have experienced.

b. Presence of Distinctive Group of Symptoms

Dr. Shoemaker's diagnosis of mold illness requires that patients display a certain pattern of symptoms. He identifies eight organ systems which are relevant to the diagnosis, and a patient must present with chronic symptoms in four of those eight organ systems in order to meet the second requirement of the first tier of his case definition.⁸ He acknowledges that no one else has

⁸ The eight organ systems are: general, musculoskeletal, head, eye, respiratory, gastrointestinal, executive cognitive functioning, and neurologic. (Tr. at 41:18-44:11.) Curiously, Dr. Shoemaker's most recent scientific study, which he says reaffirmed his case definition, required that subjects have symptoms in at least five of ten organ systems. Shoemaker, *Sick Building Syndrome and Exposure to Water Damaged Buildings*, *supra*, at 575. Antiduretic

published on the use of four out of those eight organ symptoms as a diagnostic tool for mold illness:

Q: There's no other publication that uses the four out of the eight symptoms that you've just identified to establish one leg of the mold diagnosis. Would you agree with that statement?

A: I would agree that it's not been published.

(Tr. at 49:21-25.)

At the time of Dr. Shoemaker's examination, both plaintiffs had symptoms in at least four of those organ systems, and thus met the second component of Tier 1.⁹ There are a number of problems with Dr. Shoemaker's reliance on those symptoms to conclude that plaintiffs are ill as a result of mold exposure. For one, plaintiffs' complex of symptoms did not begin immediately

hormone and hypothalamic were the additional two organ systems, with headache and skin sensitivity being grouped into a "multifactorial; unique" organ system which takes the place of "head." *Id.*

⁹ According to Dr. Shoemaker, plaintiff Young presented with: fatigue; weakness; aching; cramps; cramping of intrinsic muscles of hands and feet such that her digits assumed a claw-like posture; joint pains in feet, knees, and both hands; morning stiffness; unusual, sharp stabbing pain in side of chest and abdomen; headache; sensitivity to bright light; red eyes; tearing; profound shortness of breath; cough; sinus problems; abdominal pain with secretory diarrhea; difficulty handling abstract numbers in simple division, recent memory impairment; difficulty concentrating; decreased word finding; decreased assimilation of new knowledge; confusion; numbness and tingling in both feet; vertigo; tremors; mood swings; appetite swings; difficulty controlling body temperature; excessive thirst; frequent urination; increased susceptibility to static shocks; sensitivity to light touch. (Pls.' Ex. 55 at 15.)

Plaintiff Ghee presented with fatigue; aching; cramps; cramping of intrinsic muscles of hands such that thumbs assumed a claw-like posture; unusual, sharp stabbing pain in right lower back; headache; light sensitivity; red eyes; tearing; profound shortness of breath; sinus problems; joint pains in right knees; morning stiffness; difficulty handling abstract numbers in simple division; recent memory impairment; difficulty concentrating; decreased word finding; decreased assimilation of new knowledge; mood swings; night sweats; difficulty with temperature regulation; excessive thirst; frequent urination; increased susceptibility to static shocks; numbness and tingling in fingers and big toe on right foot. (*Id.* at 15-16.)

after exposure. Indeed, while living in the apartment, both plaintiffs complained only of respiratory symptoms. (Pls.' Ex. 10 [Ghee/Young Medical Records].) Second, the symptoms did not remain consistent over time. In November 2002, Young's medical records indicate that she reported feeling much better than she had in September. (Pls.' Ex. 12 at 0000168.) In virtually every medical record, Young reports slightly different symptoms, with many of her recurring symptoms, such as swelling in the extremities and rash, beginning many months after moving out of Apartment 2A. (Pls.' Ex. 12.) Furthermore, the vast majority of the symptoms Dr. Shoemaker reported for both plaintiffs five years after their supposed exposure are undocumented in any medical records that postdate their exposure in August-September 2002. (Pls.' Exs. 11, 12.) This is particularly evident with respect to Vanessa Ghee, whose brief medical records indicate only respiratory complaints and headaches, as opposed to the myriad of symptoms that Dr. Shoemaker attributed to her in 2007. (Pls.' Ex. 11.) There is simply no evidence that many of the symptoms Dr. Shoemaker reported existed at any time prior to his examination, and thus no evidence that those symptoms have been chronic in nature since plaintiffs' initial exposure to mold.

Furthermore, the suggestion that symptoms experienced five years after exposure to a biotoxin can be attributed to that biotoxin is unsupported by scientific literature. As defense expert Dr. S. Michael Phillips explained, "Dr. Shoemaker's findings in this case are . . . based on the false notion that biotoxins remain in the body for prolonged periods of time. This belief is misplaced and at variance with the known science of mycotoxin metabolism." (Defs.' Ex. 20 [Dr. S. Michael Phillips' Aff.] ¶ 23.) Rather, symptoms from exposure to mycotoxins are

“rapidly reversible” and should have remitted upon leaving the contaminated environment, “if that environment was causally related to symptoms,” which did not happen here. (*Id.*)

Finally, Dr. Shoemaker is unable to determine which symptoms are actually attributable to the mold. Rather, he testified that roughly 75% of plaintiffs’ symptoms are probably attributable to this mold exposure, although he cannot say which ones. (Tr. at 193:24-194:5.)¹⁰ A diagnostic process which ultimately fails to determine which symptoms are components of the illness is inherently flawed and cannot be considered scientifically valid.

Ultimately, plaintiffs’ symptoms have not had the longevity, consistency, and documentation necessary to support Dr. Shoemaker’s diagnosis. Additionally, Dr. Shoemaker’s assertions about the way symptoms of exposure to biotoxins present is unsupported by scientific literature.

c. Absence of Confounders

The third element of the first tier of Dr. Shoemaker’s diagnostic protocol is that there be an absence of confounding diagnoses and exposures. This requirement fulfills the critical purpose of a differential diagnosis, which is to conclude that only the chosen diagnosis could be

¹⁰ THE COURT: Can you say to a degree of medical certainty that 75 percent of these [symptoms] were caused by the exposure [Ghee] suffered in that building?

THE WITNESS: Yes.

THE COURT: But you can’t identify which ones, correct?

THE WITNESS: That’s correct.

Id.

responsible for the symptoms presented. Nevertheless, Dr. Shoemaker glosses over the explanation of how he ruled out all potential confounding explanations for plaintiffs' symptoms.

At numerous points in the record Dr. Shoemaker brushes off discussion of confounding diagnoses as almost irrelevant. For instance, his report merely asserts that "[t]hey had no confounding medical illnesses or environmental exposures, as confirmed by a collection of medical records forwarded to [him] before their office visit." (Pls.' Ex. 55 at 2.) He later states that nothing other than mold illness causes patients to present with chronic symptoms in four separate organ systems. (Tr. at 51:2-17.) Similarly, in reference to patients with potential confounders such as diabetes, hypertension, smoking, anxiety, or allergies, he states that "the grouping of symptoms [his] patients have with mold illness are different and the lab abnormalities that those other patients have are different." (*Id.* at 34:15-25.) However, he does not elaborate on exactly what the symptoms or abnormalities would look like in patients with those diseases. In his affidavit, he contends that "[p]otential confounders, such as allergy to trees, dander and grasses, for example, never give any abnormalities" on his Tier 2 tests like MSH and VCS. (Pls.' Ex. 14 ¶ 103.) However, the requirement that there be no confounders is part of Tier 1 of Dr. Shoemaker's case definition and should therefore be satisfied before any blood test results are known. It is insufficient for him to rely on Tier 2 results to justify his findings with respect to Tier 1.

In *Herzner*, the trial court judge pointed out that Dr. Shoemaker "does not explore the possibility that Herzner's symptoms could have been caused by several different ailments." *Herzner*, No. 2004CVC00564, at 20. In this case, Dr. Shoemaker briefly addressed this issue by saying that in his studies he "looked at [the subjects] for symptoms to try to sort out is smoking a

confounder for mold illness, or do people actually have two things . . . ?” (Tr. at 52:18-21.) In short, although he seems to be claiming that he considered the possibility that there may be more than one cause for plaintiffs’ symptoms, he provided no specific testimony as to plaintiffs, who appear to have a host of possible confounders, and he does not explain why it is implausible that several simultaneous conditions may have contributed to their symptoms.

The one potential confounder Dr. Shoemaker addresses at any length is Young’s prior diagnosis of asthma. However, he manages to use that potential confounder to support his “mold illness” diagnosis. He asserts that “the fact that she, after this exposure, . . . has countless visits in 2003, ‘04, ‘05, and ‘06 for asthma-related conditions is consistent with the hypothesis that this exposure to the water damaged building made her lung condition much worse.” (*Id.* at 214:14-18.) Rather than acknowledging that Young’s asthma-related symptoms may, in fact, have been caused by the asthma, which she apparently had prior to moving into the Stanton Glen Apartments, rather than the mold, he claims that because her asthma got worse after 2002, she must be a “mold illness” patient. (*Id.* at 214:19-24.)

Overall, Dr. Shoemaker failed to adequately demonstrate his methodology for “ruling out” other possible explanations for plaintiffs’ symptoms.

2. Tier 2

Even if Dr. Shoemaker could show that plaintiffs met the first tier of his diagnostic process, his assertion that plaintiffs meet the requirements of his second tier is based on a methodology that is not generally accepted in the scientific community. The first, and most fundamental, flaw in Dr. Shoemaker’s Tier 2 analysis is that not one of his Tier 2 biomarker tests (VCS, MSH, MMP9, ADH, ACTH) is generally accepted or clinically-validated for the purpose

of diagnosing “mold illness.” Indeed, the laboratory which performs Dr. Shoemaker’s tests for MSH, Laboratory Corporation of America [“LabCorp”], includes the following disclaimer regarding the test: “the results should not be used as a diagnostic procedure without confirmation of the diagnosis by another medically established diagnostic product or procedure” (Defs.’ Ex. 14 [LabCorp MSH Test for Young]), and the test for MMP9 includes a similar admonition. (Defs.’ Ex. 13 [Quest Diagnostic MMP-9 Test for Ghee].) Furthermore, Dr. Shoemaker admits that none of the tests he uses can affirmatively show that a person is ill because of exposure to a water-damaged building. Rather, they can only show that an inflammatory response is present in the patient, which says nothing about the cause of that response. (Pls.’ Ex. 14 ¶¶ 23, 25, 28, 30, 32, 34.)

Additionally, the idea that levels of these biomarkers five years after an exposure is in any way related to that exposure is unsupported by generally accepted science. Defendants’ expert immunologist, Dr. S. Michael Phillips, explained, for example, that “ACTH rises in the body within minutes of the stress and falls in hours after the stress. . . . [I]n the light of the short biological half-life of ACTH, the measurement of ACTH taken years after a putative exposure could not be relevant to that exposure.” (Defs.’ Ex. 20 ¶ 20.) Dr. Phillips made similar assertions with respect to C4a, another biomarker Dr. Shoemaker looks at which, although not one of his Tier 2 tests, he nonetheless uses to confirm his diagnosis. Ghee tested within the normal range for C4a, but Young was outside the normal range. (Pls.’ Ex. 14 ¶ 103.)¹¹ Dr. S. Michael Phillips explained that “C4a is an activation marker, which rises in seconds or minutes and falls to

¹¹ Dr. Shoemaker defines “normal” as less than 2830 ng/ml. Ghee tested at 2694 ng/ml, while Young had a C4a result of 10,935 ng/ml. (*Id.*)

baseline levels with[in] hours after the activation stimulus.” (Defs.’ Ex. 20 ¶ 21.) Based on this testimony, which the Court credits, testing for these biomarkers five years after an exposure cannot possibly reflect the effects of that exposure.

Furthermore, Dr. Shoemaker’s use of HLA DR genotypes to determine mold susceptibility is completely unsupported by the scientific literature. HLA DR genes are found on Chromosome 6, and “are associated with the success or failure to clear illnesses from the body.” (Pls.’ Ex. 14 ¶ 20.) Dr. Shoemaker believes that certain of these genes can cause people to be susceptible to “mold illness.” He estimates that 24% of the population has one mold susceptible HLA DR haplotype, which would make them more likely to develop “mold illness” after exposure to mold toxins. Additionally, 4% of the population has one of what Dr. Shoemaker calls the two “dreaded” haplotypes, so named because those patients have the worst clinical outcomes in response to mold exposure. The theory of a genetic basis for “mold illness” is critical to Dr. Shoemaker’s theory, for it allows him to explain how plaintiffs’ extensive symptoms can arise from a brief or mild exposure without applying the theory of a dose-response relationship. (*Id.* ¶ 131.) However, with respect to the HLA DR gene, Dr. S. Michael Phillips explained:

It is associated with various genetic linkages and diseases but has never been shown to be important in biotoxin injury. There have never been any controlled prospective studies indicating that any specific markers in the HLA or HLA-DR loci code can be linked with any mold-associated disease. In fact, Dr. Shoemaker’s “dreaded haplotypes” have previously never been linked with any mold-associated illness.

(Defs.’ Ex. 20 ¶ 16.) Furthermore, even aside from HLA DR, “[t]here are no accepted genetic markers for susceptibility to mold or toxin induced diseases.” (Defs.’ Ex. 7 at 17.) Thus, the inclusion of a diagnostic criteria based on genetics is entirely without merit.

Finally, the parameters Dr. Shoemaker has set to determine what constitutes an “abnormal” test result on these Tier 2 tests are not universally accepted in the scientific community. Indeed, they are not even recognized by the labs which he uses to perform the tests. Dr. Shoemaker defines “normal” test results for MSH as 35-81 pg/ml and for MMP9 as 0-332. LabCorp, the lab which runs the MSH tests, recently changed its normal range from 35-81 pg/ml to 0-40 pg/ml. (Pls.’ Ex. 55 at 28.) Additionally, the two labs Dr. Shoemaker regularly uses have different normal ranges for MMP9. Quest Laboratories agrees with Dr. Shoemaker that normal is 0-332, but LabCorp sets 0-983 as normal. (Defs.’ Ex. 9 at 95:16-98:21.) Given that the two national laboratories that run tests on Dr. Shoemaker’s blood samples disagree as to what constitutes a “normal” test result, it is impossible to conclude that Dr. Shoemaker’s method of assessing abnormalities in certain biomarkers is generally accepted by the scientific community. Furthermore, if LabCorp’s normal ranges are applied here, neither plaintiff has three abnormal test results, and thus, neither plaintiff meets the diagnostic criteria for Tier 2 of Dr. Shoemaker’s case definition. (Tr. at 166:8-13.)

Ultimately, Dr. Shoemaker diagnosed plaintiffs with a condition that is not recognized in the scientific community. In doing so, he used circular reasoning to work backwards from diagnosis to proof of exposure, he failed to explain exactly which symptoms comprise that diagnosis, and he did not rule out confounding diagnoses. His methodology in arriving at his diagnosis of “mold illness” is therefore unreliable.¹²

¹² Interestingly, Dr. Shoemaker does not believe his opinion was significantly affected by the five-year gap between plaintiffs’ exposure and their arrival in his office. He claims that both the symptoms and the biomarker abnormalities persist over time and thus would likely have been the same very shortly after exposure as they are now. (*Id.* at 147:15-22.) The only change in his diagnosis that would occur if it had been done five years earlier is that he could have had the

IV. CAUSATION

In a toxic tort case, “[t]he plaintiff must show that the toxicant in question is capable of causing the injury complained of (general causation) and must further prove that the toxicant in fact did cause that injury in the present case (specific causation).” Hayward, *supra*, at 533.

General causation must be affirmatively proven before specific causation can be shown. *See Raynor*, 104 F.3d at 1376 (“testimony on specific causation had legitimacy only as follow-up to admissible evidence that the drug in question *could* in general cause birth defects”) (emphasis in original). Plaintiffs have failed to sustain their burden as to both.

A. General Causation

Satisfying the general causation inquiry in this case requires a showing that the substance plaintiffs were exposed to is capable of causing the illness they experienced.¹³ The first hurdle plaintiffs must overcome is that there is no way of knowing what “substance” the plaintiffs were in fact exposed to, as Dr. Shoemaker freely admits he does not know what molds or bacteria were present in plaintiffs’ apartment in 2002, or what toxic substances were being produced at the time. (Defs.’ Ex. 9 at 203:13-206:6.) Dr. Shoemaker attempts to overcome this hurdle by referring to the “substance” in question as simply a water-damaged building. However,

apartment tested to determine what toxins were actually present while plaintiffs lived there and thus would have had a greater level of confidence regarding the substances they were exposed to. (*Id.* at 147:23-148:5.) Even if such a test could have been done, the Court cannot credit his “mold illness” as a diagnosis or his conclusions regarding plaintiffs’ diagnosis.

¹³ Plaintiffs spend a significant portion of their Opposition citing authorities in support of the contention that mold can cause human illness. (Pls.’ Opp’n at 12-21.) In so doing, plaintiffs misconstrue the nature of the general causation inquiry. Whether mold can cause any illness in humans contributes nothing to the much more specific discussion of whether toxins produced by a damp indoor environment are capable of causing the numerous, multi-system symptoms experienced by plaintiffs.

defendants' toxicology expert exposed the fallacy of referring to unspecified environmental conditions as the "substance" in view of the need to identify specific toxins and connect them to specific symptoms. (Defs.' Ex. 6 at 17.)

However, if one takes a broad view of "substance" to include "water-damaged building," and if one accepts "mold illness" as a real disease, the question that remains is whether it is generally accepted in the scientific community that exposure to a water-damaged building causes "mold illness." Even the studies cited by Dr. Shoemaker fail to establish such a connection. For example, the Environmental Protection Agency's 2004 paper, produced with the University of Connecticut, recognizes that "the notion that indoor mold growth can lead to significant toxicity in occupants of 'moldy buildings' has been very controversial in the scientific literature and likely will remain so for the foreseeable future." (Pls.' Ex. 21 [EPA/Connecticut Guidance] at 28.) Furthermore, those papers which affirm the potential for toxic effects as a result of mold exposure refer primarily to upper and lower respiratory tract symptoms (and occasionally to other symptoms such as fatigue, nausea, and headaches), but not to the multi-system symptoms that Dr. Shoemaker attributes to "mold illness." (Pls.' Ex. 22; Pls.' Ex. 23 [CDC 2005] at 24.) The Center for Disease Control also pointed out that "[the Institute of Medicine] found inadequate or insufficient evidence for a link between exposure to damp indoor environments and molds with a variety of conditions that have been attributed to toxicity." (Pls.' Ex. 23 at 24.) It is thus clear that at the present time, the scientific community is not in agreement with Dr. Shoemaker about the wide-ranging effects of exposure to non-specific toxins from water-damaged environments.

Absent a consensus in the medical community about the health effects of exposure to mold, Dr. Shoemaker is left with only his own most recent peer-reviewed publication on "mold

illness” to demonstrate general causation. However, defendants correctly highlight several deficiencies in this study. For one, the study was far too limited to stand alone as proof of general causation; only twenty-six subjects participated in the study, and the double-blinded, placebo-controlled clinical trial involved only thirteen of those subjects. (Defs.’ Reply at 4.) Furthermore, at the time of publication, LabCorp had already changed its “normal range” for the MSH blood test, such that Dr. Shoemaker’s diagnostic criteria were no longer in accordance with medically accepted standards. (Defs.’ Reply at 4; Tr. at 164:11-17.) Additionally, in the introduction to his third article, even Dr. Shoemaker acknowledges that “[t]he hypothesis that chronic exposure to the indoor environments of water-damaged buildings (WDB) causes a multi-system illness, often referred to as “sick building syndrome” (SBS), remains controversial.” Shoemaker, *Sick Building Syndrome and Exposure to Water Damaged Buildings*, *supra*, at 574.¹⁴

Given these substantial limitations and his own admission that a causal link is not generally-accepted, this single study cannot serve to establish general causation.

B. Specific Causation

¹⁴ The D.C. Superior Court pointed to similar language in Dr. Shoemaker’s second peer-reviewed publication on “mold illness” in finding a lack of evidence as to general causation. In the abstract to that paper, he stated: “[t]he human health risk for chronic illnesses involving multiple body systems following inhalation exposure to the indoor environments of water-damaged buildings (WDBs) has remained poorly characterized and the subject of intense controversy.” Shoemaker, *A Time-Series Study*, *supra*, at 29. In his affidavit, Dr. Shoemaker objects to the D.C. Superior Court’s use of that sentence to discredit his theory. He argues that “[s]aying why a paper is going to be written is standard practice; citing the reason for the paper as the same as the conclusion is illogical.” (Pls.’ Ex. 14 ¶ 105.) However, given the obvious limitations of his third paper, this study is hardly sufficient to transform his theory from “controversial” to generally-accepted.

In the absence of sufficient proof of general causation, it goes without saying that plaintiffs cannot establish specific causation. But even if they could, plaintiffs fail to offer any evidence of specific causation.

In his studies, Dr. Shoemaker has utilized a repetitive exposure protocol ["REP"] to demonstrate causation. By showing that his study participants get better with treatment, remain healthy without treatment when away from the water-damaged building, and then experience an almost immediate return of symptoms when they return to the building, he is able to rule out other environmental exposures as the source of his patients' illnesses. (Pls.' Ex. 55 at 31-32.) Dr. Shoemaker even advises his patients that with respect to proving their mold injury claims, "the most unbeatable evidence is your response to treatment and re-exposure in the 5-step repetitive exposure protocol." (Defs.' Ex. 21 [Dr. Shoemaker Website FAQ] at 3.) However, because plaintiffs moved out of their suspected mold environment five years before they went to see Dr. Shoemaker, there was no way for him to re-create the conditions that existed there five years earlier so that plaintiffs could return to that environment to determine what would happen to their symptoms. More importantly, as explained by the court in *Herzner*, Dr. Shoemaker's use of the REP to establish causation "is supported by nothing other than a temporal relationship." *Herzner*, No. 2004CVC00564, at 26. Drawing conclusions about causation from temporality is a common logical fallacy known as *post hoc ergo propter hoc* (after the fact, therefore because of the fact), and is as unpersuasive in the courts as it is in the scientific community. See, e.g., *Rolen v. Hansen Beverage Co.*, 193 F. App'x 468, 473 (6th Cir. 2006) ("Expert opinions based upon nothing more than the logical fallacy of *post hoc ergo propter hoc* typically do not pass muster under *Daubert*.").

Furthermore, although Dr. Shoemaker prescribed Cholestyramine (CSM) to both plaintiffs, neither plaintiff followed his advice, so he was unable to see how they responded to treatment. (Tr. at 19:20-23.) Importantly, Dr. Shoemaker admits that he has never before testified in a case where the plaintiffs had not at least taken the prescribed medication and shown improvement. (*Id.* at 105:23-25.) Even in other cases where he first met the plaintiffs years after their potential exposure, he had still treated them with CSM, observed their symptoms improve, and then stopped CSM treatment and demonstrated that their condition again deteriorated.¹⁵ (*Id.* at 106:23-107:3.) This case thus lacks any of the steps which Dr. Shoemaker himself has relied upon in the past to draw a direct link between an exposure and an illness.

Because he was unable to complete any part of his REP, Dr. Shoemaker claims that merely by diagnosing plaintiffs with “mold illness,” he has established evidence of causation. He asserts that because the research model for his case definition was proven in his most recently-published study, causation is established. And “once established, causation does not have to be re-invented for each repeat case.” (Pls.’ Ex. 14 ¶ 109.) This assertion is entirely without merit. In actuality, the results from his third paper merely support “the general hypothesis that SBS [Sick-Building Syndrome] is associated with exposure to WDBs [water-damaged buildings].” Shoemaker, *Sick Building Syndrome and Exposure to Water Damaged Buildings, supra*, at 583. In other words, Dr. Shoemaker himself reports that it confirms a

¹⁵ Dr. Shoemaker claims his diagnosis is actually strengthened by the fact that plaintiffs have not received any treatment for their symptoms. He states that “[t]he fact they didn’t get treatment from 2002 until when their lab database was accumulated in 2007 assists [him] because it shows that the lab abnormalities which should be durable without treatment are indeed durable” (Tr. at 198:7-11), and thus are consistent with his illness model. However, this runs directly counter to Dr. Shoemaker’s own statement on his website that response to treatment is the best evidence of mold illness. (Defs.’ Ex. 21 at 3.)

“*general hypothesis*” (one that finds no support outside of Dr. Shoemaker’s research group), not proof of *specific* causation for every future patient. Indeed, as pointed out by defendants’ expert immunologist, Dr. Shoemaker’s assertion that he need not determine causation for future patients is contrary to accepted medical principles. (Defs.’ Ex. 19 ¶ 30 (“for each new case, one must evaluate each patient on a case-by-case basis . . . to determine the most likely diagnosis and ultimately causes for that disease process”).)

Given that Dr. Shoemaker arrives at his opinions as to both general and specific causation based on novel and unaccepted theories and methodologies, plaintiffs cannot sustain their burden under *Daubert* as to causation.

V. NATURE AND EXTENT OF PLAINTIFFS’ INJURIES

Because the Court finds “mold illness” to be an unaccepted diagnosis, any testimony as to the nature or extent of plaintiffs’ injuries relating to that illness is necessarily unsupported by reliable scientific evidence. Dr. Shoemaker himself admits that without any knowledge of how each plaintiff would respond to treatment, he cannot offer an opinion as to the permanency of their symptoms. (Defs.’ Ex. 9 at 36:11-19 (“I can’t give permanency in this case, because she hasn’t even taken the first intervention that can correct this illness.”).) And similarly, he cannot say which of plaintiffs’ symptoms were caused by exposure to the damp environment of the apartment. (Tr. at 193:24-194:5.) Therefore, based on Dr. Shoemaker’s own admissions, his testimony in these areas would be nothing other than speculation.

3

4

ATO-Terminal ATCT & TRACON Facility Design Types – Executive Reference Guide

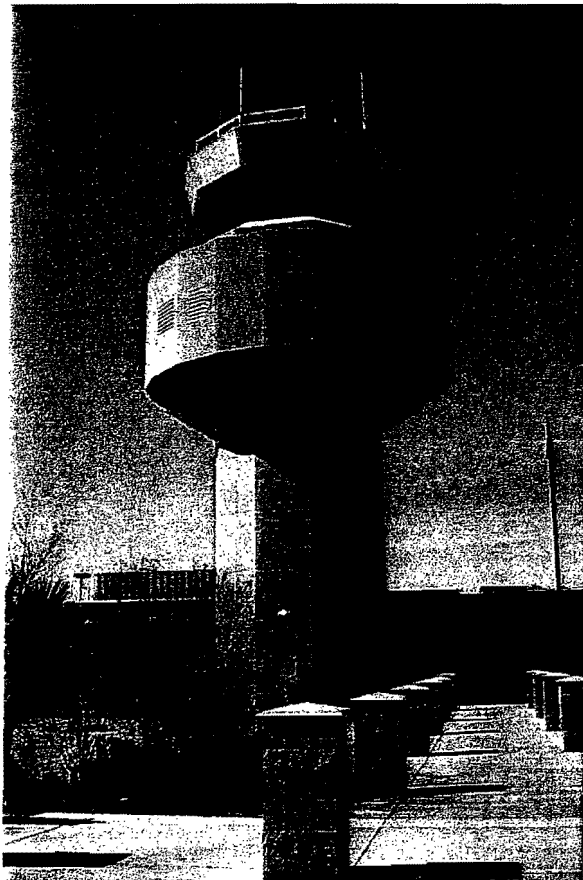

(LAL Radian VGT (North Las Vegas) ATCT)

Last Updated: March 24, 2008

Table of Contents

| | |
|--|----|
| PURPOSE | 3 |
| CONTENTS | 3 |
| BACKGROUND | 3 |
| History of the FAA | 3 |
| History of Airport Traffic Control Towers (ATCT) | 4 |
| TRACON's and CCF's | 6 |
| Other Terminal Facility Types | 6 |
| OVERVIEW | 6 |
| STANDARD ATCT DESIGN TYPES | 8 |
| Type L | 10 |
| Hunt/AVCO | 12 |
| Type O | 14 |
| Type O1 | 15 |
| Pei | 18 |
| LAL Leo Daly/HNTB | 20 |
| Golemon & Rolfe | 22 |
| Mock | 24 |
| Welton Becket | 26 |
| MAL Leo Daly | 28 |
| LAL Radian | 30 |
| IAL Radian | 32 |
| MAL Radian | 34 |

PURPOSE

The original version of this guide provided information and definitions of terminal facility design types. This updated version provides additional reference information to further explain terminal air traffic control facilities by explaining the evolution, quantifying the number of facilities, and providing information regarding the cost of sustaining the various types of facilities.

CONTENTS

This handbook contains multiple sections and appendices. The Background Section provides a basic understanding of the FAA's history and the structure within which ATO-Terminal exists. The remainder of this handbook provides a picture and brief description of the twelve (12) Standard ATCT Design Types. The information is intended to provide a basic understanding of the standard design characteristics and size. The information provided is based on the original standard designs, even though site specific variations (such as Cab size) may exist. The first page of the "ATCT Standard Design Data Sheet" can be used to visually determine the specific type of standard ATCT's.

Several appendices are included to provide additional information for terminal facilities. Appendix A provides a listing of terminal facilities and their associated design types. Appendix B provides a summary of annual sustainment costs by design type. Appendix C provides a listing of sustainment responsibilities for terminal facilities (i.e., FAA maintained or Sponsor maintained). Appendix D a listing of Facility Assessments, by location and type of assessment, that have been completed through FY2007.

BACKGROUND

The following paragraphs provide a brief history of the FAA, and introduce the differing types of terminal facilities and their evolution.

History of the FAA

The Federal Aviation Agency (FAA) was established by the Federal Aviation Act of 1958 (49 U.S.C.A. § 106). This legislation gave the Civil Aeronautics Administration (CAA) functions to this new independent body.

The U.S. Department of Transportation (DOT) was established in 1967. This cabinet level agency was made up of numerous agencies that had responsibility for air and surface transport, including the Federal Aviation Agency, whose name was then changed to the Federal Aviation Administration.

The FAA is responsible for regulating air commerce and fulfilling the requirements of national defense; controlling the use of the navigable airspace ensuring safety and efficiency; promoting, encouraging, and developing civil aeronautics; and consolidating research and development with respect to air navigation facilities. The FAA is comprised of four lines of business and 11 staff offices that are vested with fulfillment of this mission. The Air Traffic Organization (ATO) is FAA's largest line of business and is responsible for operating the National Airspace System (NAS). The ATO's mission is to "Improve continuously the safety and efficiency of aviation, while being responsible to our customers and accountable to the public."

The ATO is comprised of four operating units and five support offices. The provision of air traffic control services occur through the collaborative efforts of the four ATO operating units (i.e., Terminal, En Route & Oceanic, System Operations, Technical Operations). Terminal provides air

traffic control service in/around the airport, En Route & Oceanic provides air traffic control service between both domestic and international airports, System Operations coordinates the overall efficiency of the NAS, and Technical Operations ensures the services/equipment needed by the three operating units are available. The five support offices provide support in Finance, Communications, Safety Oversight, Business & Acquisitions, and Operations Planning. ATO's efforts to continually improve NAS services and increase NAS capacity are drivers that fuel economic growth within the aviation sector.

Within ATO-Terminal, there are three different types of terminal facilities that are used to provide terminal air traffic control services. There are Airport Traffic Control Towers (ATCT), which are located at airports throughout the United States, Puerto Rico, Guam and American Samoa, Terminal Radar Approach Control facilities (also known as TRACON's), and Combined Control Facilities (CCF).

ATCT's provide air Traffic Controllers with the ability to manage air traffic within 5 miles of the airport at an altitude of 3,000 ft, and control air traffic to and from runways and on ramps and taxiways. An example of an Airport Traffic Control Tower is the Baltimore-Washington Airport Traffic Control Tower.

TRACON's provide air Traffic Controllers with the ability to sequence and space arriving and departing traffic and manage aircraft from 5 – 40 miles away from the airport at altitudes up to 23,000 ft. An example of a TRACON is the Southern California TRACON.

CCF's provide air Traffic Controllers with the ability to provide En Route and Terminal air traffic control services in the same facility. These facilities may be co-located with an Air Traffic Control Tower or located in a separate facility.

History of Airport Traffic Control Towers (ATCT)

First some definitions are necessary to tell this story:

- Tower Cab – Air Traffic Control (ATC) area used to control airport traffic and see movement areas
- Tower Shaft – Supporting structure to give Cab level adequate height for visibility of movement areas. Shafts are described as either functional or non-functional. Functional means the shaft has space on each floor that is usable (e.g., offices, restrooms, break room, etc.). Non-functional means that the shaft is made up of space is not conditioned or designated as occupiable. A tower shaft designated as non-functional will have some floors just below the Cab level that are occupied and designated for such functional as a toilet room and limited electronic equipment needed to be located close to the Air Traffic operations area.
- Junction Level – This floor or level is usually just below the Cab level and provides a transition (junction) between the main shaft stairs and the separate stairs to the Cab.
- Tower Cab Glass – Specially designed multi-pane glass used in the tower cab to provide to air traffic controllers a clear view of the airport and arriving/departing aircraft.
- Activity Level – The activity level is a calculation based on air traffic volume and procedural complexity. The calculated value is used to determine the initial size requirements for a Tower Cab. The height of the Tower Shaft is determined based on the location of the tower on the airport and the viewing angles needed by the air traffic controllers. An ATCT can be categorized into one of three type based on Activity Level. The Low Activity Level (LAL) ATCT is used in support of smaller airports with lower volume and less complicated traffic. The next category is the Intermediate Activity Level (IAL). The largest facilities are grouped into the Major Activity Level (MAL) category.

As the aviation industry started to grow, the need for control at airports was identified. Early control was strictly visual and communication with aircraft was accomplished with colored flags.

Prior to establishment of the Federal Aviation Agency, the requirement for Airport Traffic Control Towers was placed upon the individual air carriers. The early design of the ATCT generally consisted of a 4 sided control cab constructed atop of a square/functional shaft. Many of these structures were integrated into the airport terminal complex. As such there was almost no standardization in the design of these facilities.

With government regulations of Air Traffic Control (ATC) activities came classification and standardized requirements for support facilities. Airport Traffic Control Towers were categorized by three activity levels. Low, intermediate and major activity level facilities were selected as the classifications. In the early 1960's designs were established as the standards for these three classifications. The designs completed by I. M. Pei were (and are today) generally designated Type L (Low Activity Level), Type O (Intermediate Activity Level), and Pei (Major Activity Level). A large number of these facilities were constructed to support the FAA/ATC requirements.

With the introduction of the Commuter Airlines in the late 1960's to early 1970's the need for more facilities at smaller airports prompted the need for an ATCT to match this aviation industry growth. A new "turnkey" ATCT was developed and supplied by the Hunt Corp. (the design was later modified and supplied by AVCO). This ATCT was classed as a Low Activity Level facility and designed to be easily adapted for nearly any geographic location. This design is designated as a Hunt/AVCO ATCT.

In the 1970's siting and design standards were developed that required varying Cab floor heights and room for facility expandability. The Type L and Type O designs did not allow adequate variation in Cab floor height. The Pei and Hunt/AVCO designs provided little or no provisions for facility expansion. To conform to these requirements, new standard designs were developed through the late 1970's and early 1980's. The Mock design was developed to fill the need for a Major Activity Level ATCT and the Welton Becket design was developed for a Major Activity Level ATCT/TRACON. The Golemon & Rolfe design was used for Intermediate Activity Level facilities. Note that with a reduction in commuter routes (airports), there was not a significant need for additional Low Activity Level facilities.

In the early 1990's the existing design standards were updated with new designs by Leo Daly. The design set included a Low Activity Level standard and a Major Activity Level standard (designated LAL Daly and MAL Daly). The Daly set included an Intermediate Activity Level ATCT, but due to the flexibility of the LAL design, the IAL ATCT design was not included in the FAA ATCT inventory (and as such is not depicted within this document). Although Leo Daly designs for ATCT's had been used by airport developers since the 1960's, it wasn't until this point in time that the Leo Daly designs became an integral part of the FAA Standard Designs.

In the late 1990's the requirement to reduce viewing angles through the Cab glass prompted a new series of Standard ATCT Designs that are in use today. The current design standard is designated as CLAT or Radian and more approximates a "round" ATCT configuration. From Low to Major Activity Levels, the Cabs range from 10 to 16 sides. To maximize expandability, the design set is based on a non-functional shaft (a minimum of occupied floors) with a base building designated for each activity level category. The additional number of sides to the Cab reduces the incidence of parallax when looking through multiple panes of glass at larger angles.

In summary, the early design of ATCT's generally consisted of a 4 sided control cab constructed position on top of a square/functional shaft. As the number of operations increased, the need for larger Tower Cabs and better sight lines was needed. The 4-sided Tower Cab grew to 5-side, then 6-sided, then 8-sided and even now there are 10/12/16 sided Tower Cabs.

In the early 1960's three types of standard 5-sided Tower Cab designs began to emerge. They were Type L, Type O and I.M. Pei (commonly referred to as Pei). Then in the late 1960's and early 1970's the Hunt/AVCO design began to emerge introducing a 6-sided Tower Cab, and the Mock Tower Cab design introduced another 5-sided cab. The Golemon-Rolfe 8-sided Tower Cab

was introduced in the mid-1970's. The Welton-Beckett 8-sided Tower Cab emerged in the early 1980's. In the early to mid-1980's the Leo Daly 8-sided Tower Cab was introduced. A variation on the 8-sided Leo Daly Low Activity Level Tower Cab design was introduced in this same timeframe by HNTB. Since then, ATO-Terminal has settled on three standard Tower Cab designs commonly referred to as LAL Radian (Low Activity Level-Radian), IAL Radian (Intermediate Activity Level-Radian) and MAL Radian (Major Activity Level-Radian) all of which approximate a "round" ATCT Cab design.

Even with these differing design types being introduced since the early 1960's, the largest number of terminal facilities, and for the most part the oldest, fall into the "Non-Standard ATCT" design category. These are most often sponsor built, intended to be aesthetically pleasing, and an integral part of the Airport Terminal environment. These facility types fall outside the "12 Standard" design types and also include military ATCT designs.

TRACON's and CCF's

Terminal RADAR Approach Controls (TRACON's) have been an integral part of the ATC system since the FAA was established. For example, in 1965 the Small TRACON's serving Newark, Kennedy and LaGuardia were collocated into one facility. In 1981, the New York TRACON was established becoming the first Large TRACON. Since then several other smaller TRACON's have been combined into Large TRACON's.

TRACON's that are part of a combined ATCT/TRACON are not categorized separate from the ATCT. TRACON's that are Stand-Alone facilities have a unique location identifier and are categorized as either a "Large TRACON" or "Small TRACON" design type. These two categories are based on the number of operating positions in the TRACON. Large TRACON's have 15 or more positions and Small TRACON's have less than 15.

Combined Control Facilities (CCF) are unique terminal facilities where En Route and Terminal air traffic control services are provided. There are only two CCF's in ATO-Terminal. One CCF is in Honolulu, Hawaii and provides ATCT, TRACON and En Route services. The other CCF is at Edwards Air Force Base, California and provides TRACON and En Route services.

Other Terminal Facility Types

Besides the ATC, TRACON and CCF's, there are "Mobile" ATCT and TRACON facilities. These are portable facilities, most often trailer mounted structures, usually designated for temporary deployment. These facilities are used as a temporary ATCT or TRACON supporting special needs (e.g., air shows, disaster recovery, fire-fighting operations, etc.) or modernization projects.

OVERVIEW

For purposes of tracking and reporting, terminal facilities have been categorized into one of sixteen types. The two tables below identify the different types, including twelve (12) standard designs and four other types mentioned previously.

| Twelve Standard ATCT Design Types | |
|--|-----------------|
| Design Type | |
| Type L | Type O |
| Pei | Hunt/AVCO |
| Mock | Golemon & Rolfe |
| Welton Becket | LAL Daly/HNTB |
| MAL Daly | LAL Radian |
| IAL Radian | MAL Radian |

| Four Additional Terminal Facility Types | |
|--|---------------------------|
| Non-Standard ATCT* | Small TRACON |
| Large TRACON | Mobile ATCT/Mobile TRACON |

**Non-Standard ATCT includes any unique tower design that is not associated with one of the twelve standard design types.*

STANDARD ATCT DESIGN TYPES

This section provides a brief overview of each of the 12 standard ATCT design types previously discussed. The first sheet provides a "quick reference" for generic identification of ATCT types. The description for each of the design types provides space and configuration information and an explanation of the more common design options utilized.

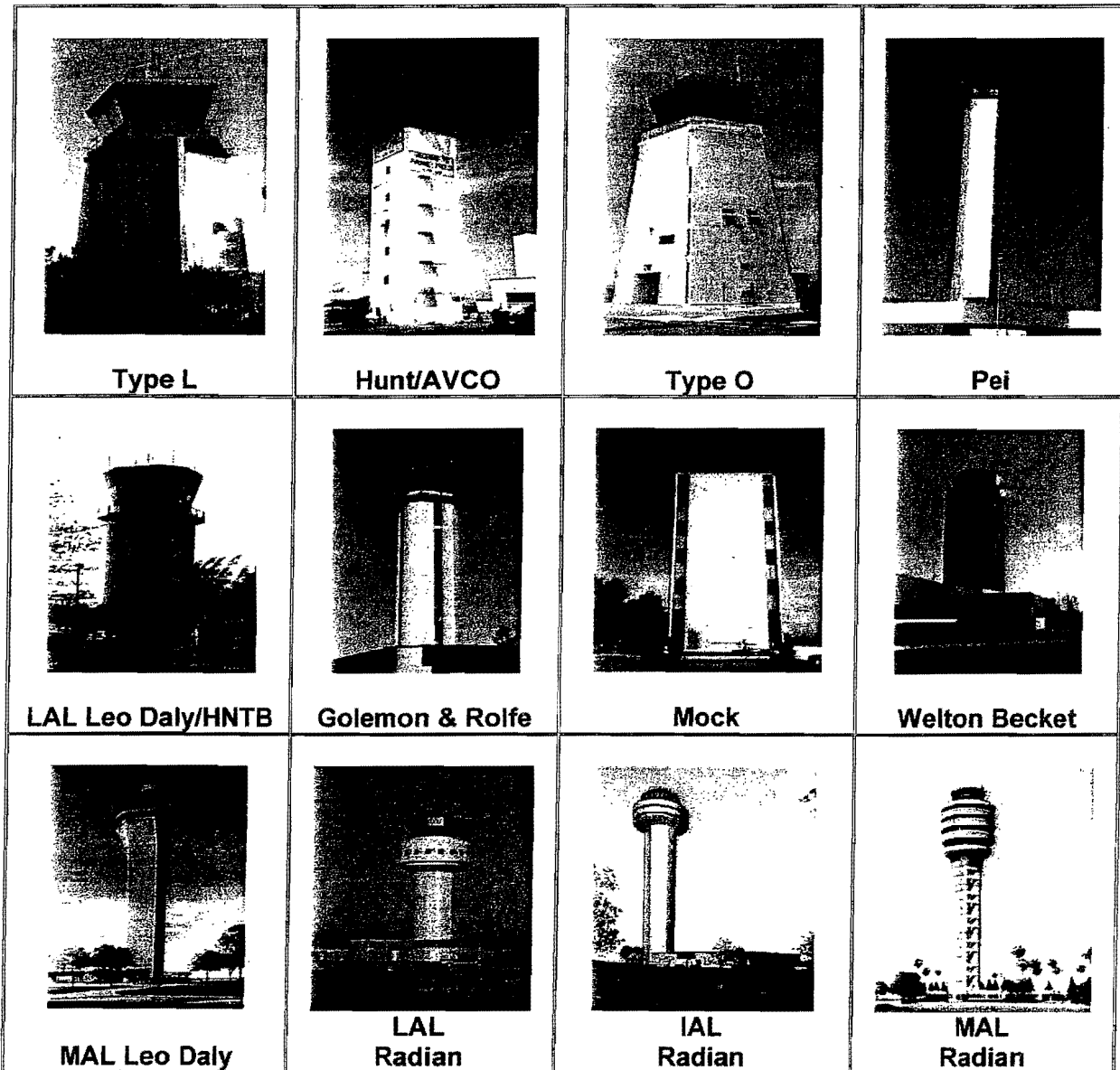

Figure 1. ATCT Standard Design Types



(Intentionally left blank)



Type L

Description: The Type L standard ATCT design consists of a square (functional) concrete shaft supporting a 5-sided (pentagon shaped) Cab. The shaft corners are finished with concrete buttress structural features (see attached picture). The standard design does not signify a "Junction Level" floor as the Cab access is via the single facility stairway. For that reason, the following description does not note a junction level.

Shaft Floor Space: The gross footprint area of the shaft is 441 square feet (21'x21' shaft measured from the wall centerline).

The first floor includes an entrance vestibule of approximately 70 square feet, the stairway of 84 square feet, and a room with a gross area of 287 square feet. In the first floor room is a cable shaft which reduces the floor area by 9 square feet resulting in a room floor area of 279 square feet.

Each floor above the first floor up to the Cab floor (2, 3, 4... as dictated by the specific facility configuration) has a nearly identical pre-occupancy layout. These floors consist of a stairway of 107 square feet and a room with a gross area of 334 square feet. In each room is a cable shaft and mechanical duct space which reduces the area by 12 square feet resulting in a room floor area of 322 square feet. On those floors (usually the level below the Cab floor) where a toilet room is included in the space of the room, that toilet room would account for approximately 43 square feet of the total room space.

Cab Floor Space: The Type L ATCT has a 5 sided (pentagon) Cab. Each wall segment measures 16' (measured along wall centerline) for a gross area of approximately 440 square feet. The Cab stairs reduce this by 50 square feet for a net Cab floor area of 390 square feet.

Elevations: The ground floor elevation will generally be 0'-6" above grade. Each subsequent shaft floor elevation will be 12' above the floor below. The Cab floor is 16' above the top shaft floor. As an example for a facility with two (2) floors plus a Cab, the Cab floor elevation would be 28'-6" above grade. With four (4) shaft floors this elevation would change to 52'-6".

For determination of the "highest point", the hand rail (where antennas and air terminals may be mounted) is 16'-6" above the Cab floor elevation. This provides a reference point for determination of the height of the highest point (antenna/lightning protection air terminal). In the examples above, the handrail elevations would be 45' and 69' above grade respectively.

The attached picture shows a 4 floor plus Cab with a resulting handrail height of 69' above grade. The picture shows standard antennas (3' in length, with a 12" mount) and a center mounted air terminal (approx. 14 feet from the antenna). A 1:1 cone of protection (rule of thumb) would result in an air terminal height of approximately 87' above grade.



Figure 2. Type "L"

Hunt/AVCO

The Hunt and AVCO standard ATCT design are functionally the same design. The space, elevations, and layout are the same except for the location of the junction level toilet room. Given the similarities, the two design types are combined under a single description for this document. (This design type is also referred to as a "Turnkey" design.)

Description: The Hunt and AVCO standard ATCT design consists of a square (functional/occupied) steel framed metal covered shaft supporting a 6-sided (hexagonal shaped) Cab (see attached picture).

Shaft Floor Space: The gross footprint area of the shaft is 306 square feet (17'-6"x17'-6" shaft measured from the wall interior). The wall interior is used to measure area as space is reduced by internal steel structural framing.

Each floor (except the junction level) is identical in layout. The only variation is from the presence or absence of an elevator (based on ATCT height configuration). Each floor consists of the stairway, mechanical chase, cable chase, small room and large room. If an elevator was included in the facility construction, it replaces the small room. Of the 306 square feet per floor, 94 square feet is taken by the stairway. The cable chase (by the stairway) and mechanical chase (by the small room) reduce the usable area by an additional 11 square feet. The small room (or elevator) has an area of 43 square feet and the large room has an area of 158 square feet.

The junction level floor is similar to the lower floors in that it includes the main stairway, chases, and small room (or elevator). The junction level also includes the Cab access stairs (reducing the usable floor space by 24 square feet) and a toilet room (approximately 30 square feet). The available space for equipment and personnel lockers is only 104 square feet.

Cab Floor Space: The Hunt (and AVCO) ATCT has a 6 sided (hexagonal) Cab. Each wall segment measures 9'-4" (measured from wall interior) for a gross area of approximately 225 square feet. The Cab stairs reduce this by 36 square feet for a net Cab floor area of 189 square feet.

Elevations: The ground floor elevation will generally be 0'-6" above grade. Each subsequent shaft floor elevation will be 10' above the floor below. The Cab floor is 14' above the top shaft floor. As an example for a facility with four (4) floors plus a Cab, the Cab floor elevation would be 44'-6" above grade.

For determination of the "highest point", the hand rail (where antennas and air terminals may be mounted) is 16' above the Cab floor elevation. This provides a reference point for determination of the height of the highest point (antenna/lightning protection air terminal).

The attached picture shows a 7-floor plus Cab with a resulting handrail height of 90' above grade. The picture shows standard double stack antennas (6' in length, with a 12" mount) and a center mounted air terminal (approx. 11 feet from the antenna). A 1:1 cone of protection (rule of thumb) would result in an air terminal height of approximately 108' above grade.



Figure 3. Hunt/AVCO ATCT

Type O

There are two distinct models of the Type O ATCT. The first has a Cab floor elevation of 48'-10" above grade and the second (Type O1) has a Cab floor elevation of 60' above grade (and includes an elevator). Beyond those major differences, shaft floor areas do vary between the two types. Both types will be discussed.

Description; The Type O standard ATCT design consists of a 5-sided (pentagonal shaped) functional/occupied shaft supporting a 5-sided (pentagonal shaped) Cab. The shaft is steel framed and steel sided and tapered toward to top (see attached picture).

Shaft Floor Space; The Type O ATCT shaft is 5-sided and tapers from the base to the Cab level. The center of each level includes the stairway, mechanical chase, and cable chase. This center feature has an area of approximately 250 square feet.

The first floor has a gross area of 1490 square feet that includes the entrance area/vestibule and center section. Adjusting for those items leaves an area of 1100 square feet.

The second, third, and fourth floors have gross areas of 1300, 1170, and 1050 square feet respectively. When adjusted for the center section, the second floor area is 1050 square feet, the third floor area is 920 square feet, and the fourth floor area is 800 square feet.

The space on the fifth floor (Junction level) is taken up with the shaft stairs, Cab access stairway, toilet room and junction room. The toilet room is approximately 20 square feet, and the junction room (which also contains the Cab HVAC supply duct) is approximately 100 square feet.

Cab Floor Space; The Type O ATCT has a 5 sided (pentagon) Cab. Each wall segment measures 16' (measured from wall centerline) for a gross area of approximately 440 square feet. Access to the Cab level is via a center circular stairway.

Elevations; The ground floor elevation will generally be 0'-6" above grade. The following floor elevations are based on the first floor being 0'-6" above grade. The second floor elevation is at 13'-6", the third floor elevation is at 22'-10", the fourth floor elevation is at 32'-2", and the fifth floor elevation is at 40'-4" above grade. The Cab floor elevation is 48'-10" above grade.

Type O1

Description; The Type O1 standard ATCT design consists of a 5-sided (pentagonal shaped) functional/occupied shaft supporting a 5-sided (pentagonal shaped) Cab. The shaft is steel framed and steel sided and tapered toward to top (see attached picture).

Shaft Floor Space; The Type O1 ATCT shaft is 5-sided and tapers from the base to the Cab level. The center of each level includes the elevator, stairway, mechanical chase, and cable chase. This center feature has an area of approximately 250 square feet.

The first floor has a gross area of 1560 square feet that includes the entrance area/vestibule and center section. Adjusting for those items leaves an area of 1170 square feet.

The second, third, fourth, and fifth floors have gross areas of 1460, 1320, 1200 and 1070 square feet respectively. When adjusted for the center section, the second floor area is 1210 square feet, the third floor area is 1070 square feet, the fourth floor area is 950 square feet, and the fifth floor area is 820 square feet.

The space on the sixth floor (Junction level) is taken up with the shaft stairs, Cab access stairway, toilet room and junction room. The toilet room is approximately 20 square feet, and the junction room (which also contains the Cab HVAC supply duct) is approximately 100 square feet.

Cab Floor Space; The Type O1 ATCT has a 5 sided (pentagon) Cab. Each wall segment measures 16' (measured from wall centerline) for a gross area of approximately 440 square feet. Access to the Cab level is via a center circular stairway. The Cab stairs reduce this by 26 square feet for a net Cab floor area of 414 square feet.

Elevations; The ground floor elevation will generally be 0'-6" above grade. The following floor elevations are based on the first floor being 0'-6" above grade. The second floor elevation is at 13'-6", the third floor elevation is at 23', the fourth floor elevation is at 32'-6", the fifth floor elevation is at 42', and the sixth floor is 51'-6" above grade. The Cab floor elevation is 60' above grade.

For determination of the "highest point", the hand rail (where antennas and air terminals may be mounted) is 16' above the Cab floor elevation. This provides a reference point for determination of the height of the highest point (antenna/lightning protection air terminal).



Figure 4. Type O ATCT



(Intentionally left blank)



Pei

Description; The Pei standard ATCT design consists of a 5-sided (pentagonal shaped) non-functional concrete shaft supporting a 5-sided (pentagonal shaped) Cab (see attached picture).

Shaft Floor Space; The Pei ATCT shaft is 5-sided measuring 12'-8" per side from the base to the Transfer level. The shaft flares out from the Transfer level to the top of the shaft (Cab level) to a side dimension of 16'. The only occupied area in the shaft is the Junction level (immediately below the Cab level). The shaft includes a center elevator, cable chases, and mechanical duct space surrounded by an access stairway up to the Junction level. The elevator provides access from the Base level to just below the Transfer level (1-1/2 floors below the Junction level). The shaft has a footprint of approximately 275 square feet. Below the ground/base floor level is an elevator equipment room having an area of approximately 85 square feet.

The only occupied area in the ATCT shaft is the Junction level. The Junction level includes the shaft access stairway, Cab stair/foyer area, space for mechanical ducting, equipment space, assignable space, and a toilet room. The equipment space/room has an area of approximately 20 square feet, the toilet room has an area of approximately 16 square feet, and the assignable space (Junction room) has an area of approximately 60 square feet.

Cab Floor Space; The Pei ATCT has a 5 sided (pentagon) Cab. Each wall segment measures 16' (measured from wall centerline) for a gross area of approximately 440 square feet. Access to the Cab level is via a center circular stairway. The Cab stairs reduce this by 26 square feet for a net Cab floor area of 414 square feet.

Elevations; For standard stairway configuration, the ATCT shaft is built in 15' increments (shaft stair landing spacing is 15'-0"). This is the standard configuration up to the Top Elevator Landing level. From the Top Elevator Landing to the Transfer level is 9'-0". The Transfer level to the Junction level is 6'-5", and from the Junction level to the Cab level (floor elevation) is 8'-11".

For determination of the "highest point", the hand rail (where antennas and air terminals may be mounted) is 16' above the Cab floor elevation. This provides a reference point for determination of the height of the highest point (antenna/lightning protection air terminal).

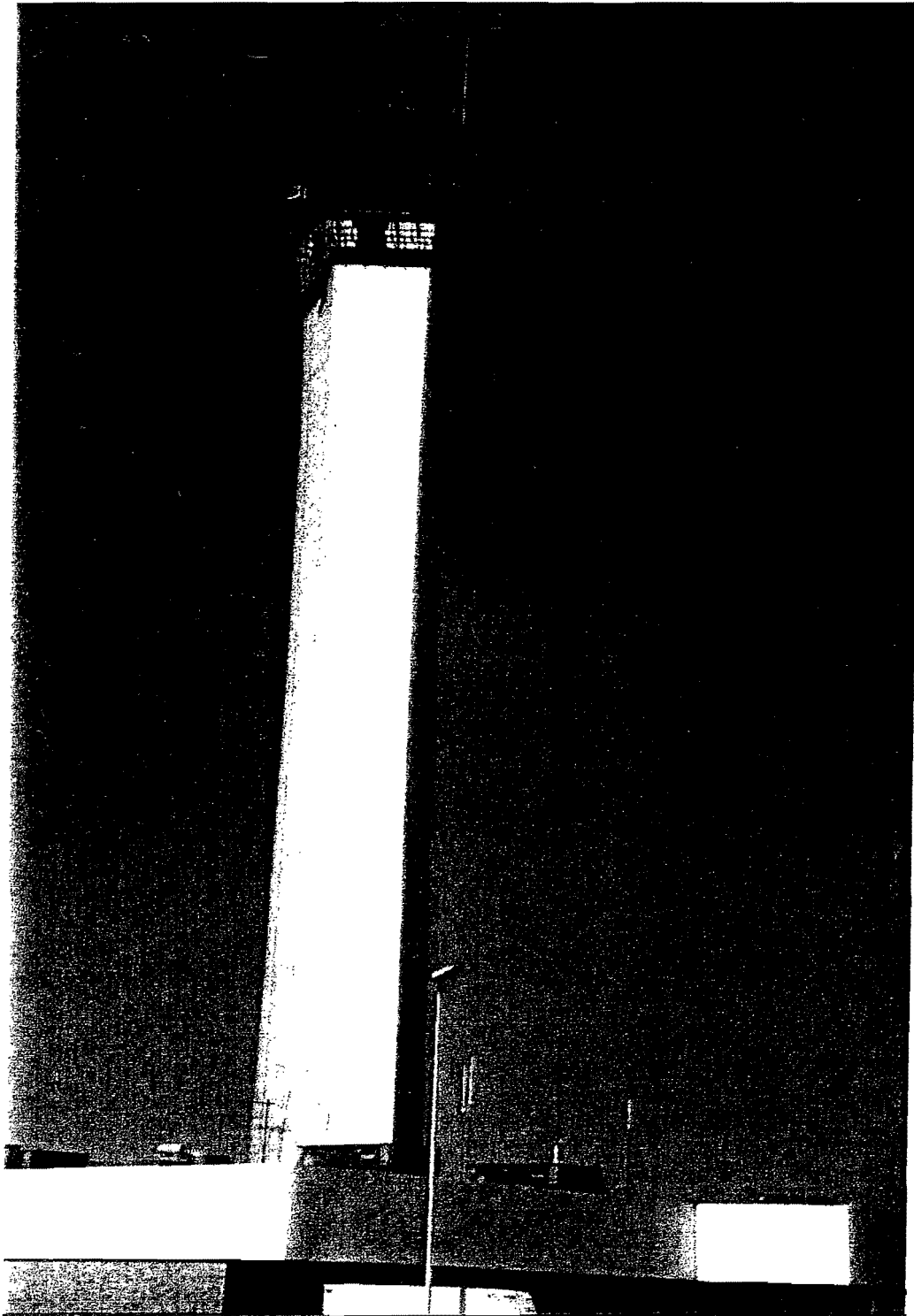

Figure 5. Pei ATCT

LAL Leo Daly/HNTB

Description; The HNTB standard ATCT design consists of a square functional steel structure/concrete panel shaft supporting an 8-sided Cab (see attached picture).

Shaft Floor Space; The gross footprint area of the shaft is 510 square feet (22'-5"x22'-5" shaft measured from the wall exterior). The gross inside area of the shaft is 400 square feet (measured from the wall interior). There are four (4) distinct floor layouts; the ground level, intermediate levels, the junction level, and the cable access level (each shaft level has the same footprint).

The ground level area is divided in the stairway (with stair pressurization equipment) of 140 square feet, elevator of 50 square feet, entrance lobby of 50 square feet, elevator equipment room of 40 square feet, a 30 square foot janitors closet, and 90 square feet for the electrical room. Each intermediate level has a gross area of 400 square feet. That area is reduced by 50 square feet from the elevator, 140 square feet from the stairway, and 10 square feet from cable and plumbing chases. This leaves 200 square feet assignable to various ATCT support functions. The Junction level has a similar layout to the intermediate levels except that approximately 40 square feet (of the 200 square foot assignable area) is dedicated to the toilet room. The cable access level has the same foot print and gross area as the other shaft levels, but since the elevator only goes to the Junction level, additional space is available at this level. The 400 square feet at the cable access level is reduced by only the 140 square feet of stairway, leaving 260 square feet available for ATCT support assignment.

Cab Floor Space; The HNTB ATCT has an 8-sided Cab with a gross area of approximately 385 square feet. The Cab stairs reduce this by 20 square feet for a net Cab floor area of 365 square feet.

Elevations; Each floor of the ground and intermediate floors raises an elevation of 10'-0" up to the Junction level (Ground floor at 0' elevation, 2nd floor at 10' elevation, 3rd floor at 20' elevation...). From the Junction level to the Cable Access level is 9'-10" and from the Cable Access level to the Cab floor is 8'-0". As a result, the Cab floor elevation will be a 10' increment plus 7'-10" (based on the total number of floors). As an example, An ATCT with six floors (including Junction and Cable Access) would have a Cab floor elevation of 57'-10".

For determination of the "highest point", from the Cab floor to the top of the raceway (where antennas would be mounted) is 18'-7". This provides a reference point for determination of the height of the highest point (antenna/lightning protection air terminal). In the example above, that elevation would be 76'-5". From that point, the highest point on the structure would be based on the location and configuration of any items mounted on the ATCT roof.



Figure 6. LAL Leo Daly/HNTB ATCT

Golemon & Rolfe

Description; The Golemon & Rolfe standard ATCT design consists of an 8-sided functional/occupied concrete shaft supporting an 8-sided Cab (see attached picture). A modified version of the Golemon & Rolfe design supports the 8-sided (525 sq. ft.) Cab designed for the Welton Beckett ATCT.

Shaft Floor Space; The Golemon & Rolfe ATCT has an 8-sided functional concrete shaft with a gross area footprint of 445 square feet (22'x22' shaft measured from the wall exterior). The gross interior space in the shaft is 380 square feet (measured from the wall interior). The standard configuration of the shaft includes five (5) distinct floor layouts. These configuration layouts are labeled as the basement level, ground level, intermediate level, sub-junction level, and walkway/junction level.

The basement level generally contains the elevation equipment and has a net floor area (less elevator pit and stairway) of 270 square feet. The ground floor includes an elevator and elevator entrance area, stairway (with exterior exit area), cable chase, and janitor's closet. The only space that can be counted as functional is the 25 square feet of the janitor's closet. Each floor above the first floor up to the sub-junction floor has an identical layout. These floors consist of a cable chase, elevator (with elevator lobby), stairway, and a small assignable room. The small room has an area of 60 square feet. The final two (2) floors at the top of the shaft are the sub-junction and junction/walkway levels. The sub-junction level for this design type includes a cable chase, elevator (with elevator lobby), cable chase, and a toilet room. The toilet room has an area of approximately 25 square feet. In addition, a part of the elevator lobby may be utilized for personal lockers (for Cab level personnel). The junction/walkway level includes a cable chase, stairway, and a facility assignable room. The available room has a floor area of approximately 185 square feet and though the ceiling height is lower than a normal room, the room is suitable for equipment installations.

Cab Floor Space; The Golemon & Rolfe ATCT has an 8-sided Cab with a gross area of approximately 385 square feet. The Cab stairs reduce this by 20 square feet for a net Cab floor area of 365 square feet.

Elevations; Each floor of the ground, intermediate, and sub-junction level floors raises an elevation of 16'-0" up to the junction/walkway level (Ground floor at 0' elevation, 2nd floor at 16' elevation, 3rd floor at 32' elevation...). From the junction/walkway level to the Cab floor is 12'-11". As a result, the Cab floor elevation will be a 16' increment plus 12'-11" (based on the total number of floors). As an example, An ATCT with six floors (including sub-junction and junction/walkway) would have a Cab floor elevation of 92'-11".

For determination of the "highest point", the raceway (where antennas and air terminals may be mounted) is 17'-7" above the Cab floor elevation. This provides a reference point for determination of the height of the highest point (antenna/lightning protection air terminal). In the example above, that elevation would be 111'-6". From that point, the highest point on the structure would be based on the location and configuration of any items mounted on the ATCT roof.

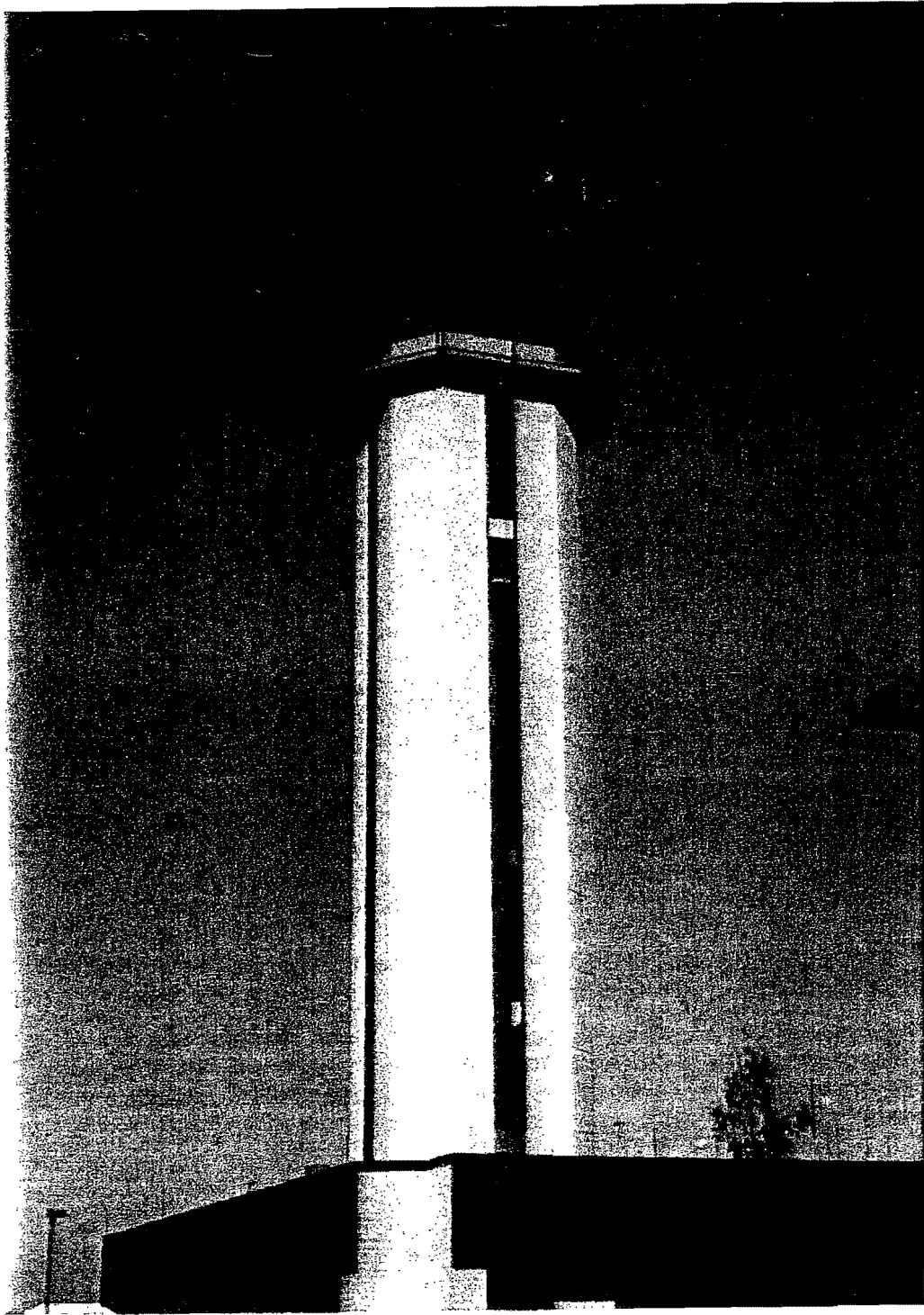

Figure 7. Golemon & Rolfe ATCT

Mock

Description; The Mock standard ATCT design consists of a 4-sided functional/occupied structural steel shaft supporting a 5-sided (pentagonal shaped) Cab (see attached picture).

Shaft Floor Space; The gross footprint area of the shaft is 1078 square feet (32'-10"x32'-10" shaft measured from the wall exterior). The gross interior space in the shaft is 990 square feet (measured from the wall interior). The standard configuration of the shaft includes three (3) distinct floor layouts. These configuration layouts are labeled as the ground level, intermediate level, and junction level.

The ground floor includes an entrance vestibule, elevator, elevator equipment room, stairway, cable chase, generator room, and two (2) rooms. Of the 990 square feet of interior space, the entrance vestibule, elevator, cable chase, and stairway reduce this amount by 275 square feet. The elevator equipment generator room equal approximately 240 square feet. This leaves 475 square feet between the two rooms. Each intermediate floor is configured to include the elevator (with vestibule), cable chase, stairway, and three (3) rooms. The three rooms can be site configured into as few as a single room, and account for approximately 740 square feet of functional space per floor. The junction level (floor just below the Cab) is similar to the intermediate levels except that an additional stairway (Cab access) reduces the floor area from 740 square feet to 630 square feet (110 square feet for the stairway).

Cab Floor Space; The original Mock ATCT design has a 5-sided (pentagon shaped) Cab. Each wall segment measures 14'-3" (measured from wall centerline) for a gross area of approximately 350 square feet. The Cab stairs reduce this by 30 square feet for a net Cab floor area of 320 square feet. The original design was later modified to use the 8-sided Cab from the Golemon & Rolfe design.

Elevations; Each floor of the ground, intermediate, and sub-junction level floors raises an elevation of 12'-1" up to the junction level (Ground floor at 0' elevation, 2nd floor at 12'-1" elevation, 3rd floor at 24'-2" elevation...). From the junction level to the Cab floor is 13'-3". As a result, the Cab floor elevation will be a 12'-1" increment plus 13'-3" (based on the total number of floors). As an example, an ATCT with six floors (including junction) would have a Cab floor elevation of 73'-8".

For determination of the "highest point", the hand rail (where antennas and air terminals may be mounted) is 16' above the Cab floor elevation. This provides a reference point for determination of the height of the highest point (antenna/lightning protection air terminal).

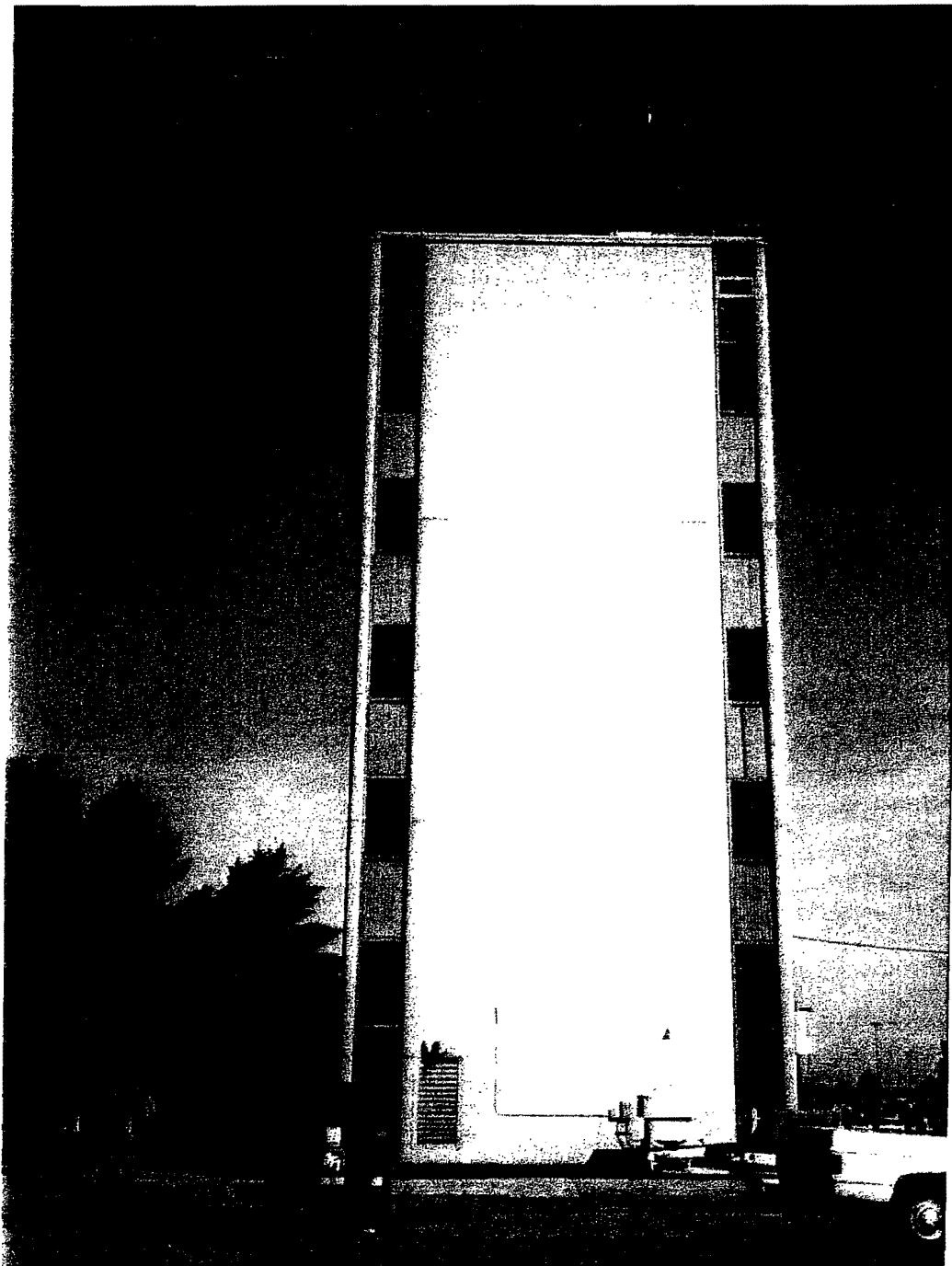

Figure 8. Mock ATCT

Welton Becket

Description; The Welton Becket standard ATCT design consists of four pre-cast concrete legs (non-functional) supporting the sub-junction and junction levels and an 8-sided Cab (see attached picture).

Shaft Floor Space; The four (4) legs of the shaft cover an area of approximately 1600 square feet (40'x40' measured from the leg exteriors). The four legs making up the shaft include a stairway, an elevator, and two (2) legs assigned as cable chases. Each leg measures 10'x10' (measured to the leg exterior). The top two (2) levels of the shaft (legs) are functional space designed as a sub-junction level and junction level. The Cab sits on top of the legs. There are four distinct level layouts within the (4 legs) shaft, the ground level, cable access level, sub-junction level, and junction level. The ground level is the elevator entrance vestibule and has an area of approximately 385 square feet. Each of the cable access levels has a grating platform within the two (2) legs utilized as cable chases. The intermediate levels may also have stair and elevator access to an exposed grated platform between legs. All of the area on each cable access level is non-functional space. The sub-junction level (with total area of 385 square feet) includes an elevator/stair lobby (highest point of elevator access to the Cab) and an equipment room (designation per original plans). The sub-junction equipment room has an area of approximately 310 square feet. If the interior partition between the elevator lobby and the equipment room has been removed, the area for the sub-junction level would equal 385 square feet. The junction level includes stairs to the Cab, a mechanical equipment room, and machine room. In addition, the junction level utilizes space above two (2) of the shaft legs. One contains a toilet room and the other contains elevator equipment. Each of the mechanical/machine rooms has approximately 100 square feet of space. The elevator machine room (above the shaft leg) has 65 square feet of area. The toilet room (above the other shaft leg) is 50 square feet in area.

Cab Floor Space; The Welton Becket ATCT has an 8-sided Cab with a gross area of approximately 500 square feet. The Cab stairs reduce this by 40 square feet for a net Cab floor area of 460 square feet.

Elevations; Each subsequent shaft level elevation above the ground level will be 15' above the level below. Additionally there are two (2) pre-cast concrete leg sections per level (each pre-cast concrete leg section measures 7'-6"). These dimensions include the sub-junction to junction to Cab (floor) levels. The Cab floor elevation (AGL) will be at a 15' multiple of levels or a 7'-6" multiple of pre-cast concrete leg sections (including the Cab catwalk ring as a leg section).

For determination of the "highest point", the raceway (where antennas and air terminals may be mounted) is 18'-0" above the Cab floor elevation. This provides a reference point for determination of the height of the highest point (antenna/lightning protection air terminal). From that point, the highest point on the structure would be based on the location and configuration of any items mounted on the ATCT roof.



Figure 9. Welton Becket ATCT

MAL Leo Daly

Description; The Leo Daly standard ATCT design consists of an 8-sided concrete shaft flaring out to support an 8-sided Cab (see attached picture).

Shaft Floor Space; The 8-sided shaft has a gross square footage of 1016 (32'x32' overall shaft measured from the inside of the exterior wall). The standard configuration of this design type has five (5) distinct floor layouts: Ground level, Shaft level, Sub-junction level, Junction level, and Cable Access level. Also, noted here is the ASDE Penthouse (located directly above the Cab level).

The Ground level includes the stairway, elevator, elevator lobby, elevator equipment room (220 square feet), electrical room (100 square feet), and mechanical space (135 square feet).

Each of the Shaft levels (1st - 13th floors) has a similar layout and space configurations. The shaft level includes space for the elevator, elevator lobby, stairway, mechanical room (60 square feet), electrical room (110 square feet), and an unassigned room (240 square feet).

The Sub-junction level is designated as an electronics equipment room (1215 square feet). This total excludes the main stairway, a stairway to the junction level, the elevator, and elevator lobby.

The Junction level includes a mechanical room (315 square feet), two (2) offices (155 square feet each), a break room (315 square feet), two (2) toilet rooms (with a small locker area equaling 225 square feet), and vestibules and wall locker spaces (320 square feet). The remaining interior Junction level space (365 square feet) is filled with the main stairway, sub-junction stairway, and elevator. Surrounding the junction level space (at the same elevation) are four microwave/antenna balconies (totaling 460 square feet).

The Cable Access level (1170 square feet excluding the stairway and elevator shaft) is located directly below the Cab. The ASDE penthouse (470 square feet of space designed for equipment) is located on the Cab roof and includes ladder access (from Cab level), equipment space, and an equipment service platform.

Cab Floor Space; The Leo Daly ATCT has an 8-sided Cab with a total area of 850 square feet (measured from the wall interior). The Cab stairs reduce this by 50 square feet for a net Cab floor area of 800 square feet.

Elevations¹; The Ground floor and Shaft level 1 through 4 have floor heights of 12' per floor. Each subsequent Shaft level is 24' above the next lower floor. The Sub-junction level is 16'- 3" above the last Shaft level. The Junction level is 11'-9" above the Sub-junction level. The Cable Access level is 12'- 4" above the Junction level. The Cab floor is 20' above the Junction level. The top of the ASDE penthouse is 23'-6 1/2" above the Cab floor, with the air terminals being approximately 40' above the Cab floor elevation.

¹ Example of floor elevations: Ground floor (0'), Shaft level 5 (60'), Shaft level 13 (252'), Sub-junction (268.25'), Junction (280'), Cable Access (292.33'), Cab floor (300').



Figure 10. MAL Leo Daly ATCT

LAL Radian

Description; The Radian LAL (Low Activity Level) standard ATCT design consists of a 10-sided (decagonal non-functional) concrete shaft supporting a 10-sided (decagonal) Cab (see attached picture).

Shaft Floor Space; The only occupied (functional) space in the shaft is at the Junction level. The junction level is an oversized annulus ring (approximately 45' diameter) located just below the Cab level. The gross area of the junction level is 1440 square feet (45'-3" dia. shaft measured from the wall exterior). The center of the junction level includes access vestibules, stairways, cable shaft, and the elevator. These reduce the available floor space by approximately 370 square feet. The remaining area (1070 square feet) is designated for electronic equipment, break room, toilet rooms, and storage closets.

Cab Floor Space; The Radian LAL ATCT is available in two (2) Cab size designs (395 square feet and 525 square feet) as required by the specific facility needs. Each is a 10-sided (decagonal) Cab. Each wall segment measures 8'-1" for the 395 sf or 9'-1" for the 525 sf (measured from wall exterior). The Cab area is calculated from the interior of the wall. The Cab stairs reduce this by 70 square feet or 85 square feet (for the 395 or 525 respectively) for a net Cab floor area of 325 or 440 square feet.

Elevations; Due to the configuration of the shaft stairway, ATCT heights will increase in increments of 32'8". The ATCT configuration would include a ground floor level, an odd number of intermediate shaft floors (1, 3, 5, 7, or 9 floors), a junction level, and Cab. Based on this configuration, the Cab floor heights would be 67'-8", 100'-4", 133'-0", 165'-8" or 198'-4" respectively. Based on the standard design drawings, the air terminal heights for these Cab floor elevations would be 30'-1" above the Cab floor elevation (97'-9", 130'-5", 163'-1", 195'-9", or 228'-5").

The Cab floor and air terminal heights are determined from the standard design drawings. The Cab floor heights are based on the standard stairway configuration and a first floor ground level of 0'-0". The Cab floor elevation should be verified from the specific facility design drawings. The air terminal heights need to be verified from the actual facility configurations.



Figure 11. LAL Radian ATCT

IAL Radian

Description; The Radian IAL (Intermediate Activity Level) standard ATCT design consists of a 12-sided (dodecagonal non-functional) concrete shaft supporting a 12-sided (dodecagonal) Cab (picture not available at this time).

Shaft Floor Space; The only occupied (functional) space in the shaft is at the Junction level. The junction level is an oversized annulus ring (12-sided configuration measuring 52'-4" across the outside walls) located just below the Cab level. The gross area of the junction level is 2030 square feet (based on interior dimensions). The center of the junction level includes an access vestibule, dual stairways, cable shaft, and the elevator. These reduce the available floor space by approximately 750 square feet. The remaining area (1280 square feet) is designated for electronic equipment, mechanical equipment, break room, toilet rooms, and storage closets.

Cab Floor Space; The Radian IAL ATCT is designed with a 12-sided (dodecagonal) 550 square foot Cab. The Cab area is calculated from the interior of the wall. The Cab stairs reduce this by 60 square feet for a net Cab floor area of 490 square feet.

Elevations; The standard design drawing set shows four different ATCT heights for this design. The height to the Cab floor for these is 214'-1", 242'-1", 270'-1", and 298'-1". Shorter ATCT configurations are possible and would be configured in shaft height increments of 28'-0" to match the configuration of the shaft stairway. Based on the standard design drawings, the air terminal heights for these Cab floor elevations would be 30'-1" above the Cab floor elevation (244'-2", 272'-2", 300'-2", or 328'-2").

The Cab floor and air terminal heights are determined from the standard design drawings. The Cab floor heights are based on the standard stairway configuration and a first floor ground level of 0'-0". The Cab floor elevation should be verified from the specific facility design drawings. The air terminal heights need to be verified from the actual facility configurations.



Figure 12. IAL Radian ATCT

MAL Radian

Description; The Radian MAL (Major Activity Level) standard ATCT design consists of a 16-sided (hexadecagonal non-functional) concrete shaft supporting a 16-sided (hexadecagonal) Cab (picture not available at this time).

Shaft Floor Space; The only occupied (functional) space in the shaft is a three floor oversized annulus ring (32-sided configuration measuring 64'-8" across the outside walls) below the Cab level. The three floors (from lower to upper) include an antenna/mechanical level, electronic equipment level, and the junction level. The gross area of the each floor of this annulus ring is 4010 square feet (based on interior dimensions). At the center of each level is an area that includes access vestibules, dual stairways, cable shaft, and the elevator. These reduce the available floor space by approximately 1130 square feet. The remaining area (2880 square feet) is designated for the function of that floor. The antenna/mechanical level is an unoccupied level finished with microwave fabric walls designated for mounting antennas and facility mechanical equipment. The electronic equipment level is designated for both FAA and non-FAA equipment, and includes a equipment work area. The junction level includes Air Traffic office space, break room, toilet rooms, and storage closets

Above the Cab level is additional functional space designated and indicated on the design drawings as an ASDE (3) penthouse. The penthouse is a 8-sided (hexagonal) room with a gross area of 340 square feet (stair access reduce this by 40 square feet leaving 300 square feet for equipment).

Cab Floor Space; The Radian MAL ATCT is designed with a 16-sided (hexadecagonal) 850 square foot Cab. The Cab area is calculated from the interior of the wall. The Cab stairs reduce this by 65 square feet for a net Cab floor area of 785 square feet.

Elevations; The standard design drawing set shows three different ATCT heights for this design. The height to the Cab floor for these is 263'-8", 291'-8", and 319'-8". Shorter ATCT configurations are possible and would be configured in shaft height increments of 28'-0" to match the configuration of the shaft stairway. Based on the standard design drawings, the air terminal heights for these Cab floor elevations would be 33'-4" above the Cab floor elevation (297'-4", 325'-4", or 353'-4"). Note that this ATCT configuration includes an ASDE (3) penthouse. With this configuration, the air terminal height above the Cab floor is usually a fixed dimension.

The Cab floor and air terminal heights are determined from the standard design drawings. The Cab floor heights are based on the standard stairway configuration and a first floor ground level of 0'-0". The Cab floor elevation should be verified from the specific facility design drawings. The air terminal heights need to be verified from the actual facility configurations.

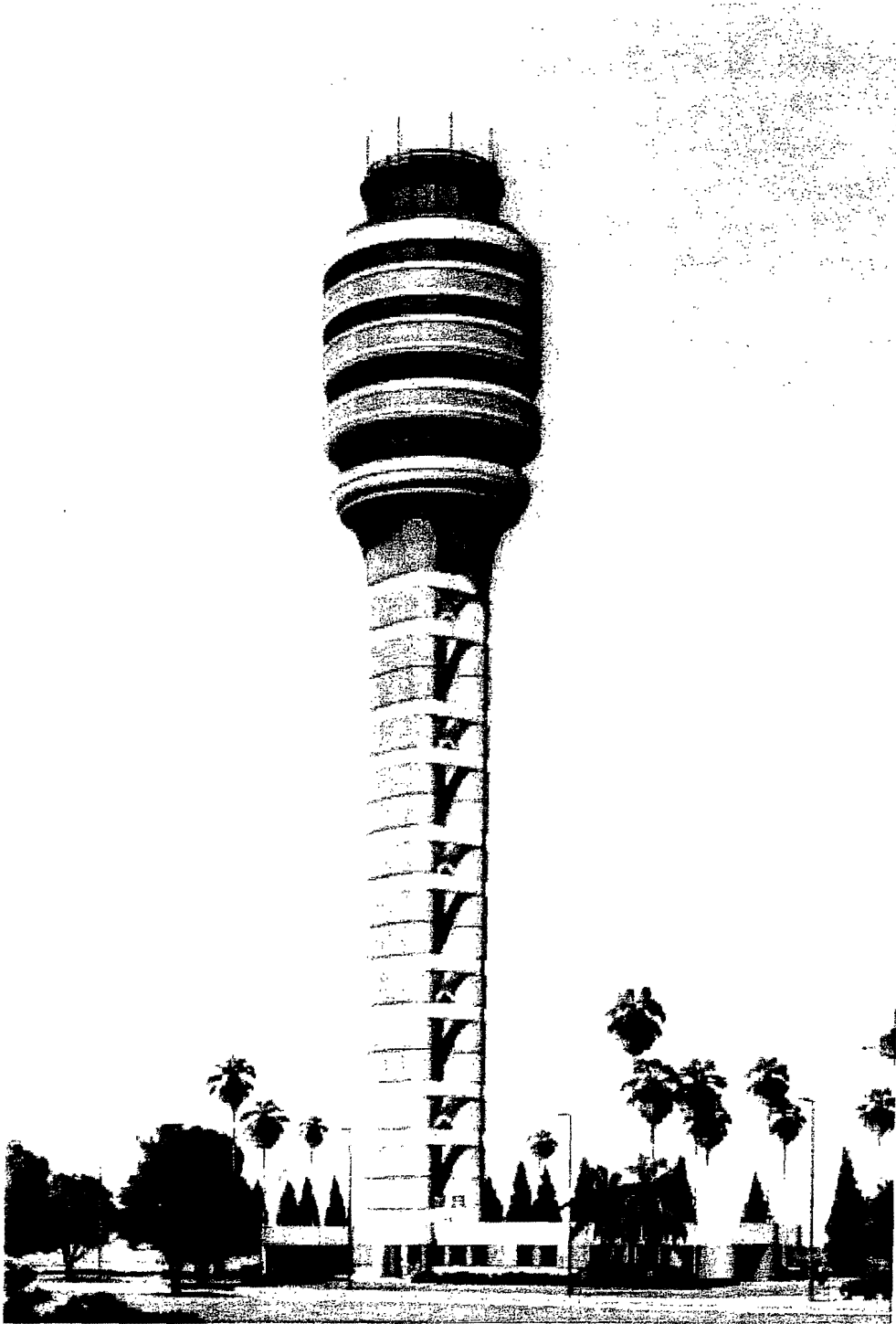

Figure 13. MAL Radian ATCT

Appendix A: ATCT Design Types/Quantities/ Maintenance & Ownership

| ATCT Design Type | Total Quantity in Terminal | # FAA Maintained | | # Sponsor Maintaned |
|------------------|----------------------------|------------------|--------------------------------|---|
| | | # FAA Owned | # Sponsor Owned - FAA Operated | # Sponsor Maintained - Non-FAA Operated |
| Type L | 3 | 3 | 0 | 0 |
| Hunt/AVCO | 92 | 88 | 1 | 3 |
| Type O | 31 | 31 | 0 | 0 |
| Pei | 17 | 16 | 1 | 0 |
| HNTB | 4 | 3 | 0 | 1 |
| Goleman & Rolfe | 35 | 33 | 2 | 0 |
| Mock | 42 | 41 | 1 | 0 |
| Welton Beckett | 25 | 23 | 1 | 1 |
| Leo Daly | 16 | 15 | 1 | 0 |
| LAL | 3 | 2 | 1 | 0 |
| IAL | 0 | 0 | 0 | 0 |
| MAL | 1 | 0 | 1 | 0 |
| Non-Standard | 234 | 60 | 51 | 123 |
| Large TRACONS | 9 | 9 | 0 | 0 |
| Small TRACONS | 18 | 12 | 6 | 0 |
| Mobile | | | | |
| Totals | 530 | 336 | 66 | 128 |

Appendix B: List of Completed Facility Condition Assessments (As of 12/31/2007)

| LocID: | City: | State: | Confirmed Design Type |
|--------|------------------|--------|-----------------------|
| ACY | Atlantic City | NJ | GOLEMAN-ROLFE |
| AGS | Augusta | GA | MOCK |
| AHN | Athens | GA | HUNT/AVCO |
| AKN | King Salmon | AK | Non-Standard |
| ALN | Alton/St Louis | IL | Type "O" |
| ANC | Anchorage | AK | Leo Daly |
| APC | Napa | CA | Type "O" |
| BFL | Bakersfield | CA | MOCK |
| BGR | Bangor | ME | GOLEMAN-ROLFE |
| BIS | Bismarck | ND | MOCK |
| BNA | Nashville | TN | WELTON-BECKETT |
| BTR | Baton Rouge | LA | GOLEMAN-ROLFE |
| CAE | Columbia | SC | Pei |
| CDW | Caldwell | NJ | HUNT/AVCO |
| CHS | Charleston | SC | WELTON-BECKETT |
| CIC | Chico | CA | HUNT/AVCO |
| CLT | Charlotte | NC | WELTON-BECKETT |
| COS | Colorado Springs | CO | WELTON-BECKETT |
| CRQ | Carlsbad | CA | HUNT/AVCO |
| D01 | Denver | CO | Large TRACON |
| DEC | Decatur | IL | Type "O" |

| LocID: | City: | State: | Confirmed Design Type |
|--------|-------------------|--------|-----------------------|
| DXR | Danbury | CT | HUNT/AVCO |
| EMT | El Monte | CA | HUNT/AVCO |
| ENA | Kenai | AK | HUNT/AVCO |
| EUG | Eugene | OR | GOLEMAN-ROLFE |
| EVV | Evansville | IN | MOCK |
| FAI | Fairbanks | AK | MOCK |
| FTW | Fort Worth | TX | Type "O" |
| FYV | Fayetteville | AR | HUNT/AVCO |
| GEG | Spokane | WA | Non-Standard |
| GON | Groton New London | CT | HUNT/AVCO |
| GRR | Grand Rapids | MI | Non-Standard |
| GSP | Greer | SC | Non-Standard |
| GTF | Great Falls | MT | Pei |
| HIO | Portland | OR | Type "O" |
| HLN | Helena | MT | MOCK |
| HPN | White Plains | NY | Pei |
| IAH | Houston | TX | Leo Daly |
| ITO | Hilo | HI | MOCK |
| L30 | Las Vegas | NV | Small TRACON |
| LAS | Las Vegas | NV | WELTON-BECKETT |
| LAW | Lawton | OK | Type "O" |
| LBB | Lubbock | TX | Pei |
| LGB | Long Beach | CA | Pei |
| LNK | Lincoln | NE | MOCK |

| LocID: | City: | State: | Confirmed Design Type |
|--------|------------------------|--------|-----------------------|
| LNS | Lancaster | PA | Type "O" |
| LOU | Louisville | KY | Type "O" |
| LVK | Livermore | CA | HUNT/AVCO |
| MDH | Carbondale/Murphysboro | IL | HUNT/AVCO |
| MEI | Meridian | MS | Type "O" |
| MEM | Memphis | TN | Pei |
| MKE | Milwaukee | WI | WELTON-BECKETT |
| MKK | Kaunakakai | HI | HUNT/AVCO |
| MMU | Morristown | NJ | Non-Standard |
| MOD | Modesto | CA | Type "O" |
| MWA | Marion | IL | HUNT/AVCO |
| MYF | San Diego | CA | Type "O" |
| N90 | Westbury | NY | Large TRACON |
| OGD | Ogden | UT | HUNT/AVCO |
| OKC | Oklahoma City | OK | Pei |
| OLM | Olympia | WA | HUNT/AVCO |
| ONT | Ontario | CA | GOLEMAN-ROLFE |
| ORD | Chicago | IL | Leo Daly |
| OWD | Nonwood | MA | HUNT/AVCO |
| PAH | Paducah | KY | HUNT/AVCO |
| PAO | Palo Alto | CA | TYPE "L" |
| PHL | Philadelphia | PA | WELTON-BECKETT |
| PHX | Phoenix | AZ | WELTON-BECKETT |
| PIH | Pocatello | ID | HUNT/AVCO |

| LocID: | City: | State: | Confirmed Design Type |
|--------|---------------------------|--------|-----------------------|
| POC | La Verne | CA | Type "O" |
| POU | Poughkeepsie | NY | HUNT/AVCO |
| PSC | Pasco | WA | HUNT/AVCO |
| PSP | Palm Springs | CA | Type "O" |
| PWM | Portland | ME | MOCK |
| RAL | Riverside | CA | Type "O" |
| RAP | Rapid City | SD | Type "O" |
| RDD | Redding | CA | HUNT/AVCO |
| RDG | Reading | PA | Type "O" |
| RHV | San Jose | CA | TYPE "L" |
| ROC | Rochester | NY | WELTON-BECKETT |
| SAT | San Antonio | TX | WELTON-BECKETT |
| SDM | San Diego | CA | HUNT/AVCO |
| SIG | San Juan | PR | HUNT/AVCO |
| SJU | San Juan | PR | Non-Standard |
| SMF | Sacramento | CA | Pei |
| SMO | Santa Monica | CA | Type "O" |
| SMX | Santa Maria | CA | HUNT/AVCO |
| SNA | Santa Ana | CA | GOLEMAN-ROLFE |
| SNS | Salinas | CA | TYPE "L" |
| SRQ | Sarasota | FL | MOCK |
| TRI | Bristol/Johnson/Kingsport | TN | Mock |
| TUS | Tucson | AZ | Non-Standard |
| UGN | Chicago/Waukegan | IL | HUNT/AVCO |

| LocID: | City: | State: | Confirmed Design Type |
|---------------|--------------|---------------|------------------------------|
| VNY | Van Nuys | CA | Type "O" |
| WDG | Enid | OK | HUNT/AVCO |
| WJF | Lancaster | CA | HUNT/AVCO |
| YKM | Yakima | WA | HUNT/AVCO |

Appendix C: Design Type Quantity/Sample Size/Assessments Completed

| ATCT Design Type | FAA Maintained Quantity | Recommended Sample Size of FAA Maintained Quantity (25%) | # of Life Cycle Assessments |
|------------------|-------------------------|--|-----------------------------|
| Type L | 3 | 2 | 3 |
| Hunt/AVCO | 89 | 23 | 28 |
| Type O | 31 | 8 | 18 |
| Pei | 17 | 5 | 8 |
| HNTB | 3 | 2 | 0 |
| Goleman & Rolfe | 35 | 9 | 6 |
| Mock | 42 | 11 | 11 |
| Welton Beckett | 24 | 6 | 10 |
| Leo Daly | 16 | 4 | 3 |
| LAL | 3 | 2 | 0 |
| IAL | 0 | 0 | 0 |
| MAL | 1 | 1 | 0 |
| Non-Standard | 111 | 28 | 7 |
| Large TRACONS | 9 | 3 | 2 |
| Small TRACONS | 18 | 5 | 1 |
| Mobile | | | |
| Totals | 402 | | 97 |